

HIC07-AA-01

Sync. Inverter Driver IC

(SEM2007)



SAMSUNG
ELECTRO-MECHANICS

Samsung Electro-Machanics

Sync. Inverter Driver IC (SEM2007)

■ FEATURES

- Single N/N type Inverter
- Main Frequency Sync. Function
- PWM Frequency Sync. Function
- Easy Burst Dimming Control
- Built-In Soft Start Function
- Built-In UVLO function
- Latched Mode Protection
- Variable Protection function

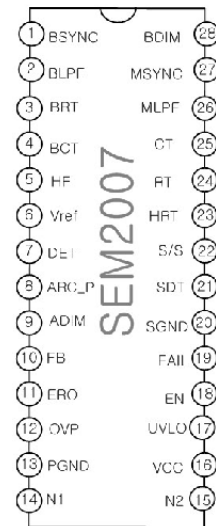

■ PIN DESCRIPTION

번호	기호	기능
1	BSYNC	Burst Sync. 신호 입력 단자
2	BLPF	Burst Sync.용 Low Pass Filter 연결 단자
3	BRT	Burst Dimming용 OSC Timing Resistor 연결단자
4	BCT	Burst Dimming용 OSC Timing Cap. 연결단자
5	HF	High Frequency Timing Cap. 연결단자
6	Vref	5V Reference Voltage Output
7	DET	Protection Detecting Input
8	ARC_P	ARC protection용 Positive 입력단자
9	ADIM	Analog Dimming 입력 단자
10	FB	Error Amplifier의 Inverting Input
11	ERO	Error Amplifier의 Output
12	OVP	Over Voltage Input
13	PGND	Power Ground
14	N1	Driver Output 1
15	N2	Driver Output 2
16	VCC	Power Supply
17	UVLO	Line Voltage Monitor & On/Off
18	EN	On/Off
19	FAIL	Protection Latch Flag
20	SGND	Signal Ground
21	SDT	Shut Down Timing Capacitor 연결단자
22	S/S	Soft Start Capacitor 연결단자
23	HRT	High Frequency용 Resistor 연결단자
24	RT	Oscillator Timing Resistor Rt 연결단자
25	CT	Oscillator Timing Capacitor Ct 연결단자
26	MLPF	Main Sync.용 Low Pass Filter 연결 단자
27	MSYNC	Main Sync. 신호 입력 단자
28	BDIM	Burst Dimming Input

■ BLOCK DIAGRAM

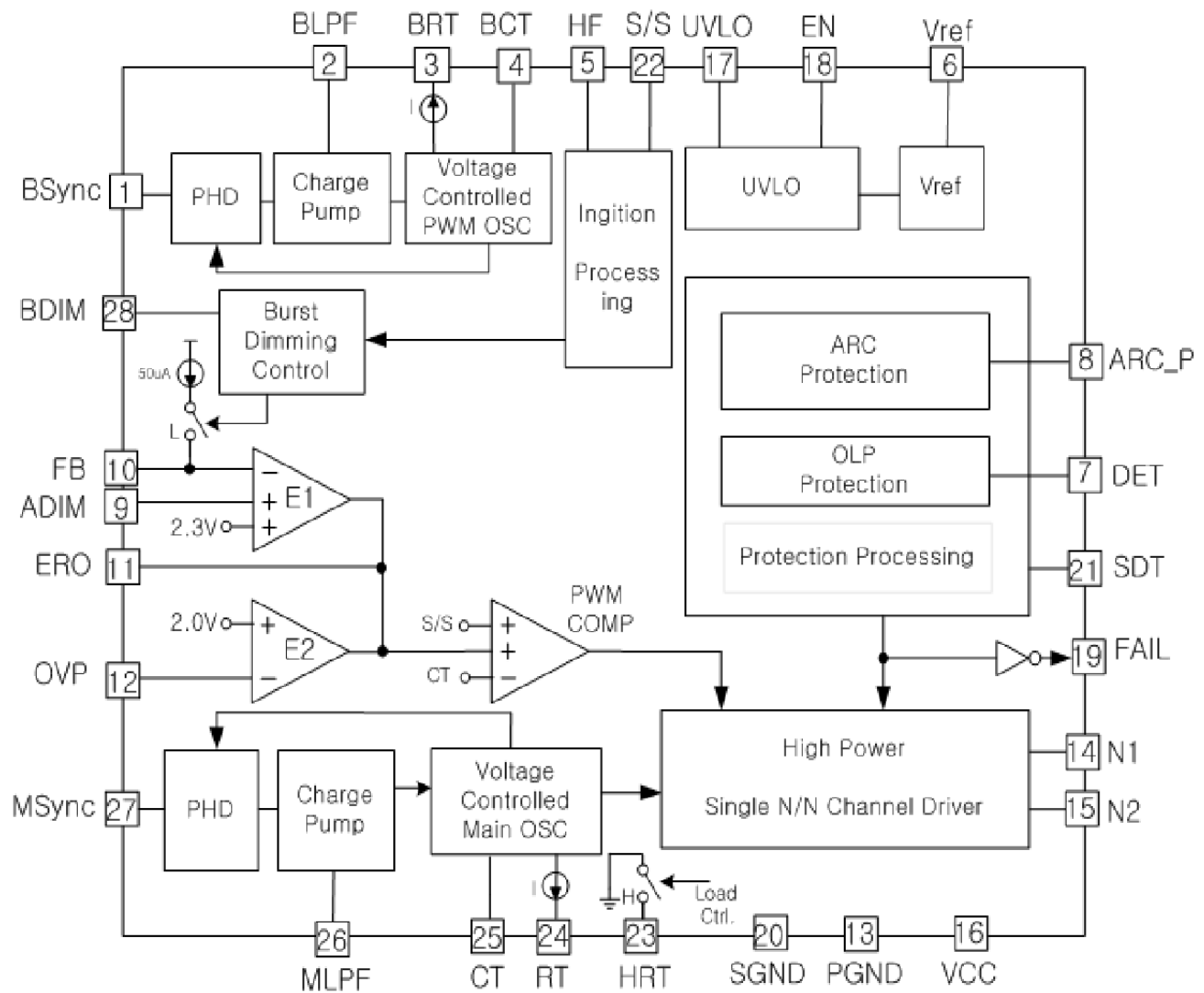

■ ORDERING INFORMATION

Device	Package	Operating Temperature
SEM2007	28-SOP	-25 ~ 85°C

■ ABSOLUTE MAXIMUM RATINGS

Characteristic	Symbol	Value	Ut
Supply Voltage	Vcc	36	V
Operating Temperature	Topr	-25 ~ 85	°C
Storage Temperature	Tstg	-55 ~ 125	
Power Dissipation	Pd	1.0	W
Maximum Junction Temperature	Tjmax	125	°C

■ ELECTRICAL CHARACTERISTICS (V_{cc}=15V, T_j=25°C; unless otherwise specified)

Characteristic	Symbol	Test Condition	Min	Typ	Max	Ut
▶ OVERALL SECTION						
Start-up Current	I _{st}	V _{cc} =15V, V _{uv} = 3.5V	-	200	400	uA
Operating Supply Current	I _{op}	V _{cc} = 15V	-	10	15	mA
Enable On Voltage	V _{en(on)}	-	2.0	-	-	V
Enable Off Voltage	V _{en(off)}	-	-	-	1.0	V
▶ UVLO SECTION						
Start Voltage	V _{st}	-	3.8	4.0	4.2	V
Hysteresis Voltage	V _{hys}	-	0.15	0.20	0.25	V
▶ REFERENCE SECTION						
Reference Output Voltage	V _{ref}	T _j =25°C, I _{ref} =1mA	4.80	5.00	5.20	V
Line Regulation	ΔV _{ref1}	10V ≤ V _{cc} ≤ 20V	-	5	20	mV
Load Regulation	ΔV _{ref2}	1mA ≤ I _{ref} ≤ 10mA	-	5	20	mV
▶ MAIN OSCILLATOR & PLL SECTION						
Main Oscillation Center Frequency	F _{osc}	T _j =25°C, RT=12k~20k	44	48	52	kHz
High Frequency	F _{hf}	RT=16k, HRT=70k~90k	63	70	77	kHz
Frequency Change	ΔF _{osc}	-25°C ≤ T _a ≤ 85°C (Note1)	-	5	-	%
Main Oscillation High Voltage	V _{rh}	-	2.8	3.0	3.2	V
Main Oscillation Low Voltage	V _{rl}	-	0.8	1.0	1.2	V
Main Sync. On Voltage	V _{msc}	-	1.0	1.4	2.0	V
▶ FEEDBACK SECTION						
FB Source Current	I _{fb}	-	30	50	70	uA
FB Input Voltage	V _{fb}	-	2.1	2.3	2.5	V
OVP Input Voltage	V _{ovp}	-	1.8	2.0	2.2	V
▶ PWM OSCILLATOR SECTION						
Burst Oscillation Center Frequency	F _{bosc}	T _j =25°C, BRT=60k~70k	135	150	165	Hz
Burst Oscillation High Voltage	V _{brh}	-	2.9	3.0	3.1	V
Burst Oscillation Low Voltage	V _{brl}	-	0.9	1.0	1.1	V
Burst Sync. On Voltage	V _{bosc}	-	1.0	1.4	2.0	V
▶ PROTECTION SECTION						
S/S Source Current	I _{ss}	-	-	2.0	4.0	uA
SDT Source Current	I _{sdt}	-	-	2.0	4.0	uA
HF Source Current	I _{hf}	-	-	2.0	4.0	uA
DET Threshold Voltage	V _{det}	-	2.7	3.0	3.3	V
OVP Threshold Voltage	V _{ovpt}	-	1.6	1.8	2.0	V
INIT Threshold Voltage	V _{init}	-	0.5	0.7	0.9	V
HF Threshold Voltage	V _{hf}	-	2.7	3.0	3.3	V
SDT Threshold Voltage	V _{shdn}	-	2.7	3.0	3.3	V
ARC Threshold Voltage	V _{arc}	-	2.7	3.0	3.3	V
▶ OUTPUT SECTION						
N1 Output Voltage	V _{no1}	T _j =25°C, C _{load} =2nF (Note1)	11.0	13.0	-	V
N2 Output Voltage	V _{no2}		11.0	13.0	-	V
N1 Rise Time	T _{n1-r}		-	100	-	ns

N1 Fall Time	Tn1-f	-	100	-	ns
N2 Rise Time	Tn2-r	-	100	-	ns
N2 Fall Time	Tn2-f	-	100	-	ns

* Note1 : These Parameters, although guaranteed over the recommended operating conditions, are not 100% tested in production

APPLICATION EXAMPLE

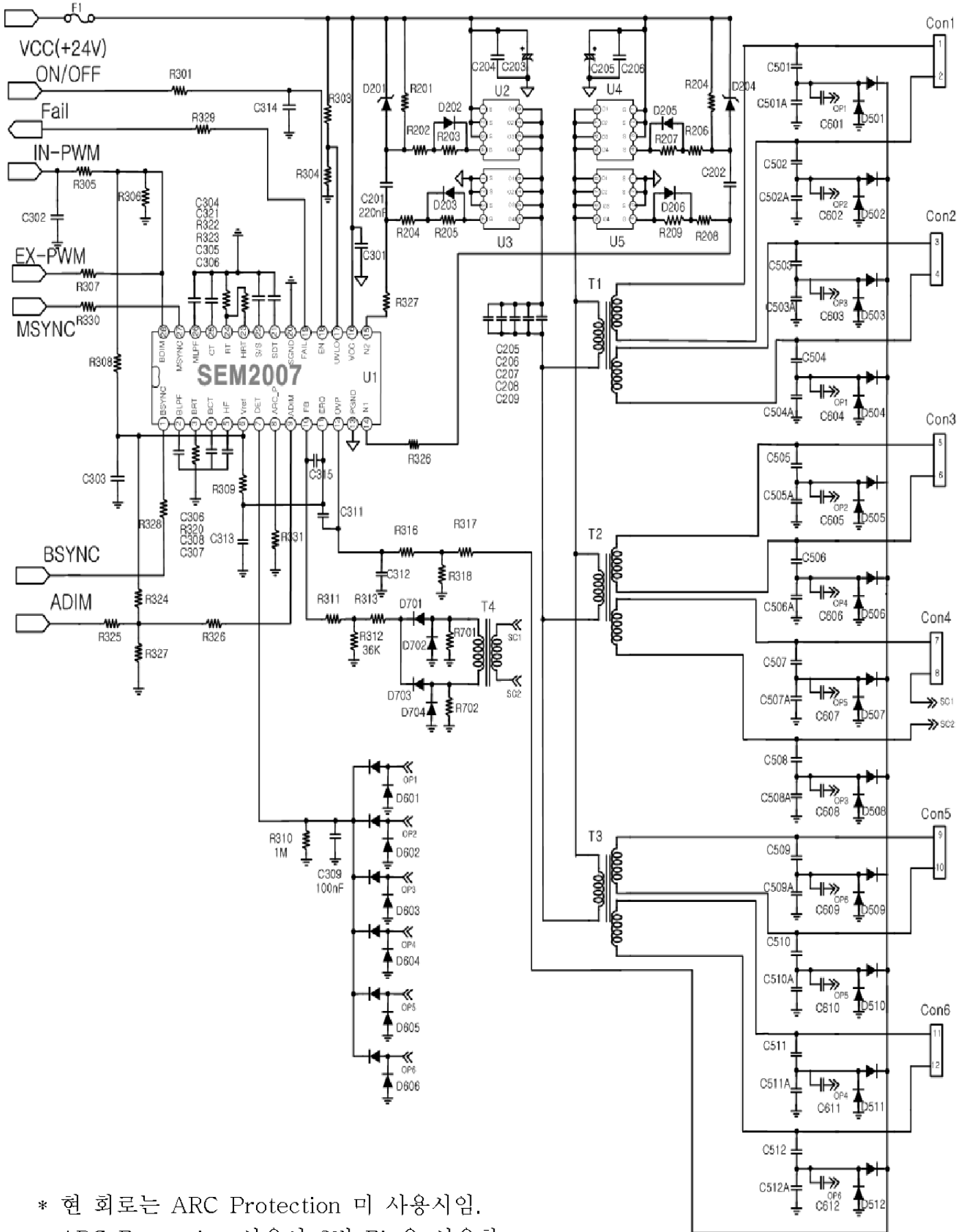

- * 현 회로는 ARC Protection 미 사용시임.
- * ARC Protection 사용시 8번 Pin을 사용함.

■ PACKAGE DIMENSION

28-SOP-375

Dimensions in millimeters

