



SANYO Semiconductors

DATA SHEET

LC723781N

LC723782N

LC723783N

LC723784

LC723785

CMOS IC

— Electronic tuning system for car audio

ETR Microcontrollers

Overview

The LC723780 Series are large-capacity ETR microcontrollers that can support up to 128KB of ROM and up to 8KB of RAM. In addition to the expanded table reference instruction to support large-capacity program ROM, the LC723780 Series provide enhanced interrupt capability to directly control CD mechanism and CD-DSP, and the capability to support the RDS models. They also have a built-in serial I/O port and an 8-input 8-bit A/D converter for communicating with the internal and external devices, and for minimizing the connecting wire between the front panel board and the main board, particularly for car audio systems.

The on-chip high-performance PLL circuit provides a high-speed lock circuit used to search for alternative frequencies of RDS in a short time, the ability to control the C/N characteristics of a local oscillator, and the high S/N through the direct PLL configuration.

Functions

- ROM : Up to 64K steps (65,535×16-bits)
The subroutine area holds 4K steps (4,096×16-bits)
- RAM : Up to 16K×4-bits (In banks 00 through FF)
LC723781N-ROM : 40KB, RAM : 2KB
LC723782N-ROM : 48KB, RAM : 2KB
LC723783N-ROM : 64KB, RAM : 4KB
LC723784-ROM : 96KB, RAM : 6KB
LC723785-ROM : 128KB, RAM : 8KB
- Stack : 32levels

■ Any and all SANYO Semiconductor products described or contained herein do not have specifications that can handle applications that require extremely high levels of reliability, such as life-support systems, aircraft's control systems, or other applications whose failure can be reasonably expected to result in serious physical and/or material damage. Consult with your SANYO Semiconductor representative nearest you before using any SANYO Semiconductor products described or contained herein in such applications.

■ SANYO Semiconductor assumes no responsibility for equipment failures that result from using products at values that exceed, even momentarily, rated values (such as maximum ratings, operating condition ranges, or other parameters) listed in products specifications of any and all SANYO Semiconductor products described or contained herein.

SANYO Semiconductor Co., Ltd.

TOKYO OFFICE Tokyo Bldg., 1-10, 1 Chome, Ueno, Taito-ku, TOKYO, 110-8534 JAPAN

LC723781N/723782N/723783N/723784/723785

- Serial I/O : Three channels. These circuits can support both 2-wire and 3-wire 8-bit communication techniques, and can be switched between MSB first and LSB first operation.
One of six internally generated serial transfer clock rates can be selected: 12.5kHz, 37.5kHz, 187.5kHz, 281.25kHz, 375kHz, and 450kHz
- External interrupts : Seven interrupt inputs (pins INT0 through INT5, and the HOLD pin)
These interrupts can be set to switch between rising and falling edges, although the HOLD pin only supports falling edge detection.
- Internal interrupts : Seven interrupts ; four internal timer interrupts, and three serial I/O interrupts.

Functions (Continued)

- Interrupt nesting levels : 16 levels
Interrupts are prioritized in hardware as follows :
HOLD pin>INT0 pin>INT1 pin>INT2 pin>INT3 pin>INT4 pin>INT5 pin>
S-I/O0>S-I/O1>S-I/O2>Internal TMR0>Internal TMR1>Internal TMR2>
Internal TMR3
- A/D Converter : 8-bit resolution and 8 inputs
- General-purpose ports : Input ports : 13
Output ports : 4
I/O ports : 62 (These pins can be switched between input and output in 1-bit units.)
- PLL block : Includes a sub-charge pump for high-speed locking.
Supports dead zone control.
Built-in unlock detection circuit
Twelve reference frequencies : 1kHz, 3kHz, 3.125kHz, 5kHz, 6.25kHz, 9kHz, 10kHz, 12.5kHz, 25kHz, 30kHz, 50kHz, and 100kHz
- Universal counter : This 20-bit counter can be used for either frequency or period measurement and supports four measurement (calculation) periods : 1ms, 4ms, 8ms, and 32ms
- Timers : Two fixed timers and two programmable timers (8-bit counters)
TMR0 : Supports four periods : 10 μ s, 100 μ s, 1ms, and 5ms
TMR1 : Supports four periods : 10 μ s, 100 μ s, 1ms, and 10ms
TMR2 and TMR3 : Programmable 8-bit counters.
Input clocks with 10 μ s, 100 μ s, and 1ms
One 125-ms timer flip-flop provided
- Beep circuit : Provides 12 fixed beep tones :
500Hz, 1kHz, 2kHz, 2.08kHz, 2.2kHz, 2.5kHz, 3kHz, 3.125kHz, 3.33kHz, 3.75kHz, 4.17kHz, and 7.03kHz
Programmable 8-bit beep tone generator.
Reference clocks with frequencies of 50kHz, 15kHz, and 5kHz.
- Reset : Built-in voltage detection reset circuit
External reset pin
- Cycle time : 1.33 μ s/833ns (All instructions are one word), X'tal : 4.5MHz/7.2MHz
Supports software switching (Initial cycle time is 1.33 μ s)
- Halt mode : The microcontroller operating clock is stopped in Halt mode.
There are four conditions that can clear Halt mode : Interrupt requests, timer flip-flop overflows, port PA inputs, and HOLD pin inputs.
- Operating supply voltage : 4.5 to 5.5V (Microcontroller block only : 3.5 to 5.5V)
- Package : QIP100E
- OTP version : LC72F3781
- Development tools : Emulator : RE128V
Evaluation chip : LC72EV3780
Evaluation board : EB-72EV3780

LC723781N/723782N/723783N/723784/723785

Specifications

Absolute Maximum Ratings at $T_a = 25^\circ\text{C}$ $V_{SS} = 0\text{V}$

Parameter	Symbol	Conditions	Ratings	Unit
Maximum supply voltage	V_{DD} max		-0.3 to +6.5	V
Input voltage	V_{IN1}	PC-PORT	-0.3 to +8	V
	V_{IN2}	All input pins other than V_{IN1}	-0.3 to $V_{DD}+0.3$	V
Output voltage	V_{OUT1}	PJ-PORT	-0.3 to +14	V
	V_{OUT2}	PC-PORT	-0.3 to +8	V
	V_{OUT3}	All input pins other than V_{OUT1} and V_{OUT2}	-0.3 to $V_{DD}+0.3$	V
Output current	I_{OUT1}	PC, PJ-PORT	0 to +5	mA
	I_{OUT2}	PB, PD, PE, PF, PG, PK, PL, PM, PN, PO, PP, PQ, PR, PS, PT-PORT, EO1, EO2, SUBPD	0 to +3	mA
Allowable power dissipation	P_d max	$T_a = -40$ to $+85^\circ\text{C}$	400	mW
Operating temperature	T_{opr}		-40 to +85	$^\circ\text{C}$
Storage temperature	T_{stg}		-40 to +125	$^\circ\text{C}$

Allowable Operating Range at $T_a = -40$ to $+85^\circ\text{C}$, $V_{DD} = 3.5$ to 5.5V

Parameter	Symbol	Pins	Ratings			Unit
			min	typ	mx	
Supply voltage	V_{DD1}	CPU and PLL operation	4.5	5.0	5.5	V
	V_{DD2}	CPU operation	3.5		5.5	
	V_{DD3}	Memory retention	1.1		5.5	
Input high-level voltage	V_{IH1}	PB, PC, PH, PI, PL, PM, PN, PP, PO, PQ, PR, PS, PT-PORT, HCTR, LCTR, INEO, SUBPD (with the I/O ports set to input mode)	$0.7V_{DD}$		V_{DD}	V
	V_{IH2}	PD, PE, PF, PG, PK-PORT, LCTR (in period measurement mode), $\overline{\text{HOLD}}$, $\overline{\text{RESET}}$	$0.8V_{DD}$		V_{DD}	V
	V_{IH3}	$\overline{\text{SNS}}$	2.5		V_{DD}	V
	V_{IH4}	PA-PORT	$0.6V_{DD}$		V_{DD}	V
Input low-level voltage	V_{IL1}	PB, PC, PH, PI, PL, PM, PN, PP, PO, PQ, PR, PS, PT-PORT, HCTR, LCTR, INEO, SUBPD (with the I/O ports set to input mode)	0		$0.3V_{DD}$	V
	V_{IL2}	PA, PD, PE, PF, PG, PK-PORT, LCTR (in period measurement mode), $\overline{\text{RESET}}$	0		$0.2V_{DD}$	V
	V_{IL3}	$\overline{\text{SNS}}$	0		1.1	V
	V_{IL4}	$\overline{\text{HOLD}}$	0		$0.4V_{DD}$	V
Input frequency	F_{IN1}	XIN	4.0	4.5	8.0	MHz
	F_{IN2}	$F_{MIN} : V_{IN2}, V_{DD1}$	10		150	MHz
	F_{IN3}	$F_{MIN} : V_{IN3}, V_{DD1}$	10		130	MHz
	F_{IN4}	$A_{MIN}(H) : V_{IN3}, V_{DD1}$	2.0		40	MHz
	F_{IN5}	$A_{MIN}(L) : V_{IN3}, V_{DD1}$	0.5		10	MHz
	F_{IN6}	$HCTR : V_{IN3}, V_{DD1}$	0.4		12	MHz
	F_{IN7}	$LCTR : V_{IN3}, V_{DD1}$	100		500	kHz
	F_{IN8}	$LCTR$ (in period measurement) : $V_{IH2}, V_{IL2}, V_{DD1}$	1		20×10^3	Hz
Input amplitude	V_{IN1}	XIN	0.5		1.5	V _{rms}
	V_{IN2}	F_{MIN}	0.07		1.5	V _{rms}
	V_{IN3}	$F_{MIN}, A_{MIN}, HCTR, LCTR$	0.04		1.5	V _{rms}
Input voltage range	V_{IN6}	AD10 to AD17	0		V_{DD}	V

LC723781N/723782N/723783N/723784/723785

Electrical Characteristics in the allowable operating ranges

Parameter	Symbol	Pins	Ratings			unit
			min	typ	max	
Input high-level current	I _{IH1}	XIN : V _I = V _{DD} = 5.0V	2.0	5.0	15	μA
	I _{IH2}	FMIN, AMIN, HCTR, LCTR : V _I = V _{DD} = 5.0V	4.0	10	30	μA
	I _{IH3}	PA, PB, PC, PD, PE, PF, PG, PH, PI, PK, PL, PM, PN, PO, PP, PQ, PR, PS, PT-PORT, <u>SNS</u> , <u>HOLD</u> , <u>RESET</u> , HCTR, LCTR, INEO, SUBPD : V _I = V _{DD} = 5.0V (with the ports PB, PC, PD, PE, PF, PG, PK, PL, PM, PN, PP, PO, PQ, PR, PS, and PT-PORT set to input mode)			3	μA
Input low-level current	I _{IL1}	XIN : V _I = V _{DD} = V _{SS}	2.0	5.0	15	μA
	I _{IL2}	FMIN, AMIN, HCTR, LCTR : V _I = V _{DD} = V _{SS}	4.0	10	30	μA
	I _{IL3}	PA, PB, PC, PD, PE, PF, PG, PH, PI, PK, PL, PM, PN, PO, PP, PQ, PR, PS, PT-PORT, <u>SNS</u> , <u>HOLD</u> , <u>RESET</u> , HCTR, LCTR, INEO, SUBPD : V _I = V _{SS} (with the ports PB, PC, PD, PE, PF, PG, PK, PL, PM, PN, PP, PO, PQ, PR, PS, and PT-PORT set to input mode)			3	μA
Hysteresis	VH	PD, PE, PF, PG, PK-PORT, <u>RESET</u> , LCTR (in period measurement)	0.1V _{DD}	0.2V _{DD}		V
Output high-level voltage	V _{OH1}	PB, PD, PE, PF, PG, PK, PL, PM, PN, PO, PP, PQ, PR, PS, PT-PORT : I _O = -1mA	V _{DD} -1.0			V
	V _{OH2}	EO1, EO2, SUBPD : I _O = -500μA	V _{DD} -1.0			V
	V _{OH3}	XOUT : I _O = -200μA	V _{DD} -1.0			V
Output low-level voltage	V _{OL1}	PB, PD, PE, PF, PG, PK, PL, PM, PN, PO, PP, PQ, PR, PS, PT-PORT : I _O = -1mA			1.0	V
	V _{OL2}	EO1, EO2, SUBPD : I _O = -500μA			1.0	V
	V _{OL3}	XOUT : I _O = -200μA			1.5	V
	V _{OL4}	PC, PJ-PORT : I _O = -5mA			2.0	V
Output off leakage current	I _{OFF1}	PB, PD, PE, PF, PG, PK, PL, PM, PN, PO, PP, PQ, PR, PS, PT-PORT	-3		3	μA
	I _{OFF2}	EO1, EO2, SUBPD	-100		100	nA
	I _{OFF3}	PC, PJ-PORT	-5		5	μA
A/D conversion error		AD10 to AD17	-1.5		+1.5	LSB
Rejected pulse width	PREJ1	<u>SNS</u>			50	μs
Power down detection voltage	VDET		2.7	3.0	3.3	V
Power supply current	I _{DD1}	V _{DD1} : F _{IN2} = 130MHz Ta = 25°C, X'tal : 4.5MHz		5	10	mA
	I _{DD2}	V _{DD1} : F _{IN2} = 130MHz Ta = 25°C, X'tal : 7.2MHz		5.5	11	mA
	I _{DD3}	V _{DD2} : Halt mode Ta = 25°C, X'tal : 4.5 MHz *1 (Fig. 1)		0.45		mA
	I _{DD4}	V _{DD2} : Halt mode Ta = 25°C, X'tal : 7.2MHz		0.55		mA
	I _{DD5}	Backup mode (OSC stopped) V _{DD} = 5.5V, Ta = 25°C *2 (Fig. 2)			5	μA
	I _{DD6}	Backup mode (OSC stopped) V _{DD} = 2.5V, Ta = 25°C *2 (Fig. 2)			1	μA

*1 : Twenty instruction steps are executed every millisecond. The PLL, universal counter, and other functions are stopped.

Test Circuits

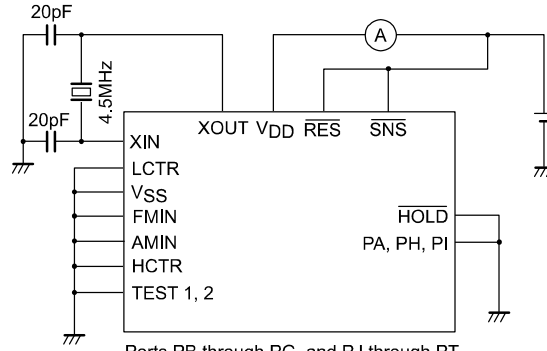

Ports PB through PG, and PJ through PT are all left open. However, ports PB through PG, PK through PT, SUBPD are left open in output mode.

ILC05525

Figure 1. I_{DD2} in Halt Mode

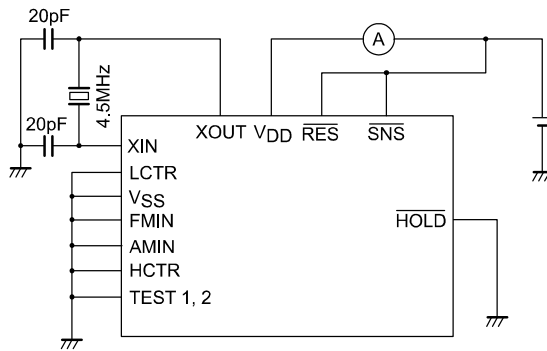

Ports PA through PT are all left open.

ILC05526

Figure 2. I_{DD3} and I_{DD4} in Backup Mode

Package Dimensions

unit : mm

3151A

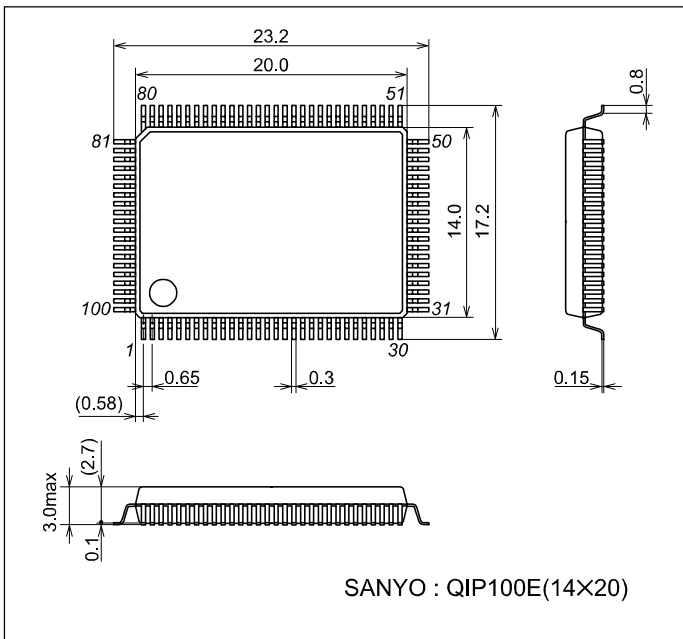

LC723781N/723782N/723783N/723784/723785

Pin Assignment

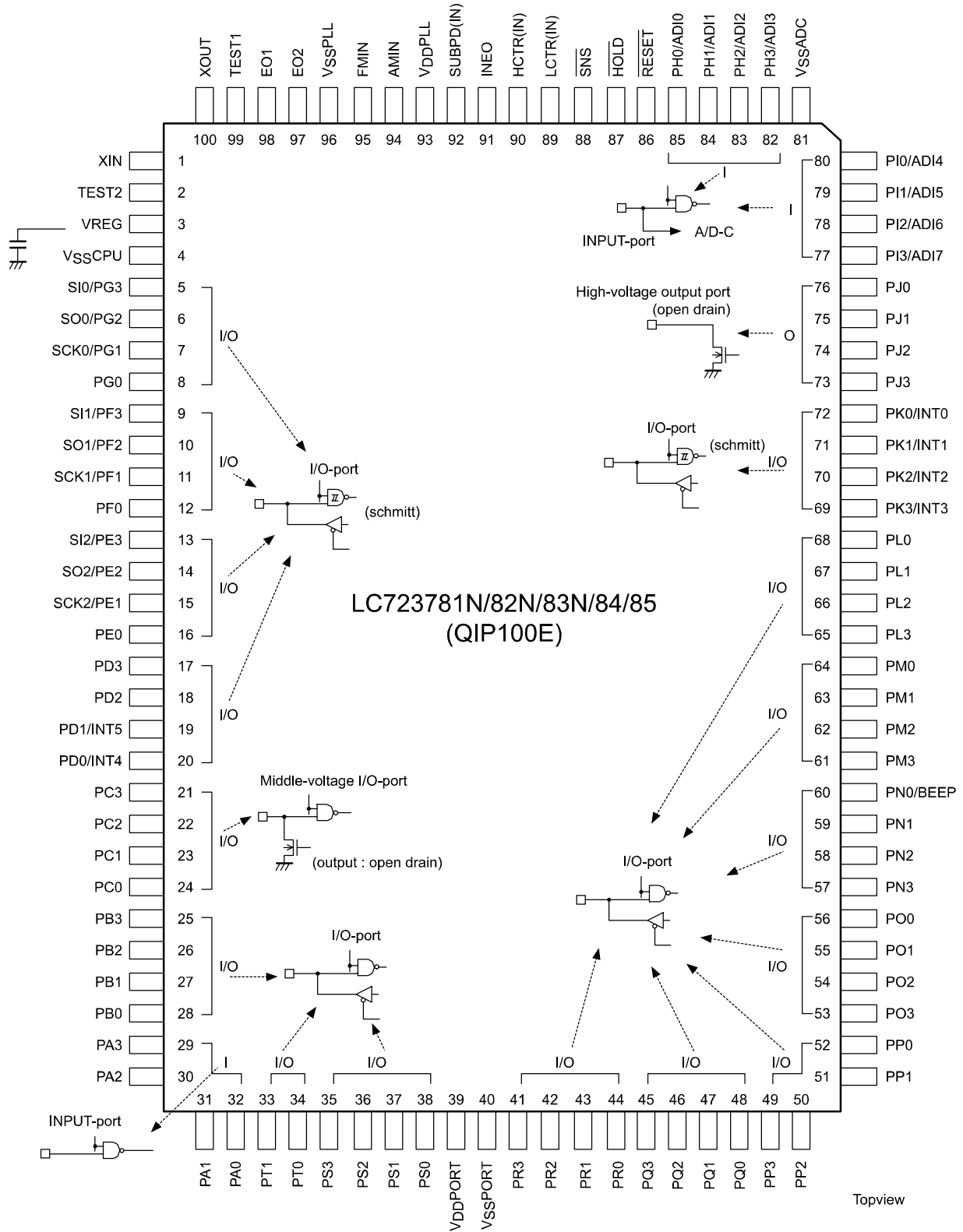

ILC05527

Block Diagram

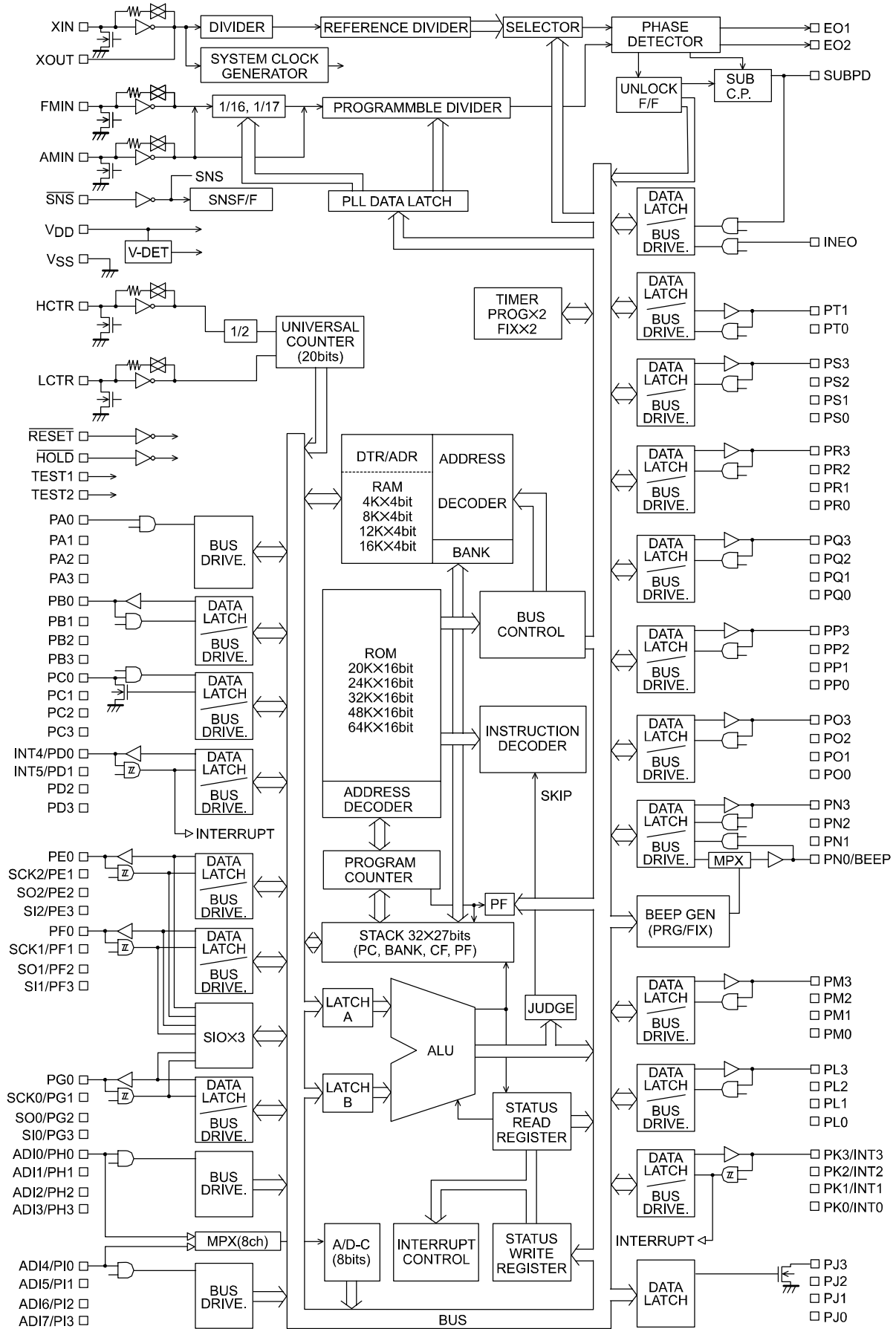

Pin Description

Pin name	Pin No.	I/O	Pin explanation	Equivalent circuit
PA0 PA1 PA2 PA3	32 31 30 29	I	Dedicated input ports. These ports are designed with a low threshold voltage. Input is disabled in Backup mode.	<p>ILC05529</p>
PB0 PB1 PB2 PB3	28 27 26 25	I/O	General-purpose I/O ports. The mode (input or output) is set using the IOS2 instruction. Input is disabled and the pins go to the high-impedance state in Backup mode. These ports are set up as general-purpose input ports after a power on reset.	<p>ILC05530</p>
PC0 PC1 PC2 PC3	24 23 22 21	I/O	General-purpose I/O ports (middle-voltage input and output). The mode (input or output) is set using the IOS2 instruction. External pull-up resistors are required since the output circuits are open drain. Input is disabled and the pins go to the high-impedance state in Backup mode. These ports are set up as general-purpose input ports after a power on reset.	<p>ILC05531</p>
PD0/INT4 PD1/INT5 PD2 PD3	20 19 18 17	I/O	General-purpose I/O and external interrupt shared function ports. The input formats are Schmitt inputs. The external interrupt function is enabled when the external interrupt enable flag is set. <ul style="list-style-type: none"> When used as general-purpose I/O ports : The mode (input or output) is set in 1-bit units using the IOS2 instruction. When used as external interrupt pins : The external interrupt functions are enabled by setting the corresponding external interrupt enable flag (INT4EN or INT5EN). In this case, the pins must be set to input mode in advance. Input is disabled and the pins go to the high-impedance state in Backup mode. These ports are set up as general-purpose input ports after a power on reset.	<p>ILC05532</p>

Continued on next page.

LC723781N/723782N/723783N/723784/723785

Continued from preceding page.

Pin name	Pin No.	I/O	Pin explanation	Equivalent circuit
PE0 PE1/SCK2 PE2/SO2 PE3/SI2 PF0 PF1/SCK1 PF2/SO1 PF3/SI1 PG0 PG1/SCK0 PG2/SO0 PG3/SI0	16 15 14 13 12 11 10 9 8 7 6 5	I/O	<p>General-purpose I/O ports with shared functions as serial I/O ports. The input formats are Schmitt inputs. The PE1/SCK2 and PE2/SO2 pins can be switched to function as open drain outputs.</p> <p>The IOS1 instruction is used to switch between the general-purpose I/O port and serial I/O port functions.</p> <ul style="list-style-type: none"> When used as general-purpose I/O ports : The pins are set to the general-purpose I/O port function using the IOS1 instruction. When used serial I/O ports : The pins are set to the serial I/O port function using the IOS1 instruction. <p>[Pin states when set to the serial I/O port function] PE0, PF0, PG0 ... General-purpose I/O PE1, PF1, PG1 ... SCK input or output PE2, PF2, PG2 ... SO output PE3, PF3, PG3 ... SI input</p> <p>The PE1/SCK2 and PE2/SO2 pins can be switched to function as open drain outputs with the IOS2 instruction. When using this circuit type, the external pull-up resistors must be connected to the same power supply as that used by the IC.</p> <p>Input is disabled and the pins go to the high-impedance state in Backup mode.</p> <p>These ports are set up as general-purpose input ports after a power on reset.</p>	<p style="text-align: right;">ILC05532</p> <p style="text-align: right;">ILC05533</p>
XIN XOUT	1 100	I O	Connections for 4.5MHz/7.2MHz crystal oscillator element	<p style="text-align: right;">ILC05534</p>
EO1 EO2	98 97	O	<p>Main charge pump outputs.</p> <p>These pins output a high level when the frequency of the local oscillator divided by n is higher than that of the reference frequency, and they output a low level when that frequency is lower. They go to the high-impedance state when the frequencies match.</p> <p>These pins go to the high-impedance state in Backup mode, after a power on reset, and in the PLL stopped state.</p>	<p style="text-align: right;">ILC05535</p>
V _{DD} PORT V _{DD} PLL V _{SS} CPU V _{SS} PORT V _{SS} ADC V _{SS} PLL	39 93 4 40 81 96	-	<p>Power supply connections.</p> <p>The V_{DD}PORT and V_{SS}PORT pins are mainly supply power for the peripheral I/O blocks.</p> <p>The V_{DD}PLL and V_{SS}PLL pins are mainly for the PLL circuits and the regulator.</p> <p>The V_{SS}CPU pin is mainly used by the CPU block.</p> <p>The V_{SS}ADC pin is mainly used by the ADC block.</p> <p>Since all the V_{DD} and V_{SS} pins are independent, all must be connected to the same power supply.</p>	
VREG	3	O	<p>Internal low voltage output.</p> <p>Connect a bypass capacitor to this pin.</p>	

Continued on next page.

LC723781N/723782N/723783N/723784/723785

Continued from preceding page.

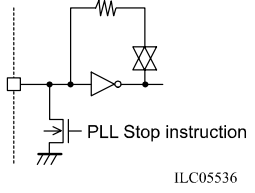
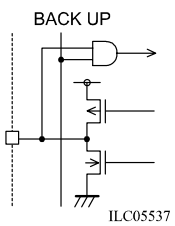
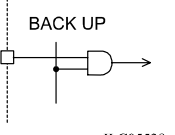
Pin name	Pin No.	I/O	Pin explanation	Equivalent circuit															
FMIN	95	I	<p>FM VCO (local oscillator) input.</p> <p>This pin is selected with CW1 in the PLL instruction.</p> <p>The signal input to this pin must be capacitor coupled.</p> <p>Input is disabled in Backup mode, after a power on reset, and in the PLL stopped state.</p>																
AMIN	94	I	<p>AM VCO (local oscillator) input.</p> <p>This pin is selected and the band set with CW1 (b1, b0) in the PLL instruction.</p> <table border="1" style="margin: 10px auto; border-collapse: collapse;"> <thead> <tr> <th>b1</th> <th>b0</th> <th>Band</th> </tr> </thead> <tbody> <tr> <td>1</td> <td>0</td> <td>2 to 40MHz (SW, AM upconversion)</td> </tr> <tr> <td>1</td> <td>1</td> <td>0.5 to 10MHz (MW, LW)</td> </tr> </tbody> </table> <p>The signal input to this pin must be capacitor coupled.</p> <p>Input is disabled in Backup mode, after a power on reset, and in the PLL stopped state.</p>		b1	b0	Band	1	0	2 to 40MHz (SW, AM upconversion)	1	1	0.5 to 10MHz (MW, LW)						
b1	b0	Band																	
1	0	2 to 40MHz (SW, AM upconversion)																	
1	1	0.5 to 10MHz (MW, LW)																	
SUBPD	92	I/O	<p>Sub-charge pump output and general-purpose input shared function port.</p> <p>The IOS2 instruction is used for switching between the sub-charge pump output and general-purpose input functions.</p> <ul style="list-style-type: none"> When used as the sub-charge pump output : <p>The sub-charge pump output function is set up with the IOS2 instruction.</p> <p>A high-speed locking circuit can be formed by using this pin in conjunction with the main charge pump.</p> <p>The sub-charge pump is controlled using the DZC instruction.</p> <table border="1" style="margin: 10px auto; border-collapse: collapse;"> <thead> <tr> <th>b3</th> <th>b2</th> <th>Operation</th> </tr> </thead> <tbody> <tr> <td>0</td> <td>0</td> <td>High impedance</td> </tr> <tr> <td>0</td> <td>1</td> <td>Only operates when the PLL is unlocked (450kHz)</td> </tr> <tr> <td>1</td> <td>0</td> <td>Only operates when the PLL is unlocked (900kHz)</td> </tr> <tr> <td>1</td> <td>1</td> <td>Normal operation</td> </tr> </tbody> </table> When used as a general-purpose input : <p>The general-purpose input function is set up with the IOS2 instruction.</p> <p>Data is read from the port using the INR instruction.</p> <p>This pin goes to the high-impedance state in Backup mode, after a power on reset, and in the PLL stopped state.</p> 	b3	b2	Operation	0	0	High impedance	0	1	Only operates when the PLL is unlocked (450kHz)	1	0	Only operates when the PLL is unlocked (900kHz)	1	1	Normal operation	
b3	b2	Operation																	
0	0	High impedance																	
0	1	Only operates when the PLL is unlocked (450kHz)																	
1	0	Only operates when the PLL is unlocked (900kHz)																	
1	1	Normal operation																	
INEO	91	I	<p>Dedicated input port.</p> <p>Data is read from the port using the INR instruction</p> <p>Input is disabled in Backup mode.</p>																

Continued on next page.

LC723781N/723782N/723783N/723784/723785

Continued from preceding page.

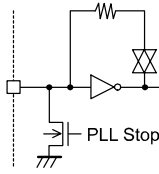
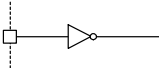
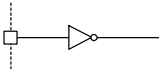
Pin name	Pin No.	I/O	Pin explanation	Equivalent circuit
HCTR	90	I	<p>Universal counter and general-purpose input shared function input port. The IOS1 instruction is used for switching between the universal counter and general-purpose input functions.</p> <ul style="list-style-type: none"> When used for frequency measurement : The universal counter function is set up with the IOS1 instruction. The counter is controlled using UCS and UCC instructions. Since this pin functions as an AC amplifier in this mode, the input signal must be input with capacitor coupling. When used as a general-purpose input pin : The general-purpose input function is set up with the IOS1 instruction. Data is read from the port using the INR (b0) instruction. Input is disabled in Backup mode. (The input pin will be pulled down.) The universal counter function is selected after a power on reset. 	
LCTR	89	I	<p>Universal counter (frequency or period measurement) and general-purpose input shared function input port. The IOS1 instruction is used for switching between the universal counter and general-purpose input functions.</p> <ul style="list-style-type: none"> When used for frequency measurement : The universal counter function is set up with the IOS1 instruction. Set up LCTR frequency measurement mode with the UCS instruction, and control operation with the UCC instruction. Since this pin functions as an AC amplifier in this mode, the input signal must be input with capacitor coupling. When used for period measurement : The universal counter function is set up with the IOS1 instruction. Set up LCTR frequency measurement mode with the UCS instruction, and control operation with the UCC instruction. Since the bias feedback resistor is disconnected in this mode, the input signal must be input with DC coupling. When used as a general-purpose input pin : The general-purpose input port function is set up with the IOS1 instruction. Data is read from the port using the INR (b1) instruction. Input is disabled in Backup mode. (The input pin will be pulled down.) The universal counter function (HCTR frequency measurement mode) is selected after a power on reset. 	 <p style="text-align: right;">ILC05536</p>
SNS	88	I	<p>Voltage sense and general-purpose input shared function port. This input circuit is designed with a low input threshold voltage.</p> <ul style="list-style-type: none"> When used as a voltage sense input : The pin is used to test for power failures on the return from Backup mode. Application can test this condition using the internal SNS flip-flop. The SNS flip-flop can be tested with the TST instruction. (This usage requires external components, capacitors and resistors. For the sample application circuit, see the user's manual.) When used as a general-purpose input port : When used as a general-purpose input port the pin state can be tested with the TST instruction. Unlike the other input ports, input to this pin is not disabled in Backup mode and after a power on reset. As a result, through currents must be taken into account when designing applications that use this pin as a general-purpose input. 	 <p style="text-align: right;">ILC05539</p>
HOLD	87	I	<p>Power supply monitor (with interrupt function) This is designed with a high input threshold voltage. This pin is normally connected to the ACC line and used for power off detection. When a power off state is detected, the HOLDON flag and the hold interrupt request flag will be set. To enter Backup mode, execute a CKSTP instruction when the HOLD pin is low. Set this pin high to clear Backup mode.</p>	 <p style="text-align: right;">ILC05539</p>

Continued on next page.

LC723781N/723782N/723783N/723784/723785

Continued from preceding page.

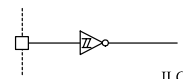
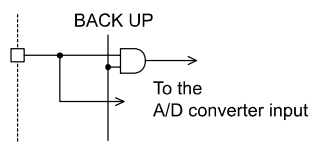
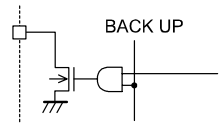
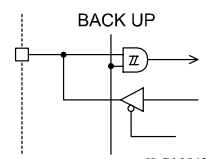
Pin name	Pin No.	I/O	Pin explanation	Equivalent circuit
RESET	86	I	<p>System reset pin.</p> <p>When the CPU is operating or in Halt mode, the system is reset when this pin is held low for at least one machine cycle. Execution starts with the PC pointing to location 0. At this time the SNS flip-flop is set. A low level must be applied for at least 50ms when power is first applied.</p>	
PH0/ADI0 PH1/ADI1 PH2/ADI2 PH3/ADI3 PI0/ADI4 PI1/ADI5 PI2/ADI6 PI3/ADI7	85 84 83 82 81 80 79 78	I	<p>General-purpose input and A/D converter input shared function ports. The IOS1 instruction is used to switch between the general-purpose input and the A/D converter input functions.</p> <ul style="list-style-type: none"> When used as general-purpose input ports : The general-purpose input port function is set up with the IOS1 instruction. (In bit units) When used as A/D converter input pins : The A/D converter input port function is set up with the IOS1 instruction. (In bit units) <p>The pin whose voltage is to be converted is specified with the IOS1 instruction, and the conversion is started with UCC instruction.</p> <p>Note : Since input is disabled for ports specified for the ADI function, executing an input instruction for such a port will always return a low level.</p> <p>Input is disabled in Backup mode.</p> <p>These ports are set up as general-purpose input ports after a power on reset.</p>	
PJ0 PJ1 PJ2 PJ3	76 75 74 73	O	<p>General-purpose output ports (high-voltage output)</p> <p>Since these are open-drain output circuits, external pull-up resistors are required.</p> <p>The internal transistors are turned off (resulting in a high-level output) in Backup mode and after a power on reset.</p>	
PK0/INT0 PK1/INT1 PK2/INT2 PK3/INT3	72 71 70 69	I/O	<p>General-purpose I/O and external interrupt shared function ports. The input formats are Schmitt inputs.</p> <p>The external interrupt function is enabled when the external interrupt enable flag is set.</p> <ul style="list-style-type: none"> When used as general-purpose I/O ports : The mode (input or output) is set in 1-bit units using the IOS1 instruction. When used as external interrupt pins : The external interrupt functions are enabled by setting the corresponding external interrupt enable flag (INT0EN through INT3EN). Here, the pins must be set to input mode in advance. <p>Input is disabled and the pins go to the high-impedance state in Backup mode.</p> <p>These ports are set up as general-purpose input ports after a power on reset.</p>	

Continued on next page.

LC723781N/723782N/723783N/723784/723785

Continued from preceding page.

Pin name	Pin No.	I/O	Pin explanation	Equivalent circuit
PL0 to 3 PM0 to 3	68 to 61	I/O	<p>General-purpose I/O ports</p> <p>The mode is switched between input and output with the IOS instruction.</p> <p>Input is disabled and the pins go to the high-impedance state in Backup mode.</p> <p>These ports are set up as general-purpose input ports after a power on reset.</p>	
PN0/BEEP PN1 PN2 PN3	60 59 58 57	I/O	<p>General-purpose I/O port and beep tone output shared function ports.</p> <p>The IOS2 instruction is used to switch between the general-purpose I/O port and the beep tone output functions.</p> <ul style="list-style-type: none"> When used as general-purpose I/O ports : The general-purpose I/O port function is set up with the IOS2 instruction. (Pins PN1 through PN3 are dedicated general-purpose output pins.) When used as the beep tone output pin : The beep tone output function is set up with the BEEP instruction. The frequency is set up with the BEEP instruction. When this pin is used as the beep tone output pin, executing an output instruction for this pin only sets the internal latch and has no influence on the output. <p>Input is disabled and the pins go to the high-impedance state in Backup mode.</p> <p>These ports are set up as general-purpose input ports after a power on reset.</p>	
PO0 to 3 PP0 to 3	56 to 49	I/O	<p>General-purpose I/O ports</p> <p>The mode is switched between input and output with the IOS instruction.</p> <p>Input is disabled and the pins go to the high-impedance state in Backup mode.</p> <p>These ports are set up as general-purpose input ports after a power on reset.</p>	
PQ0 to 3 PR0 to 3 PS0 to 3 PT0 to 3	48 to 41 38 to 33	I/O	<p>General-purpose I/O ports.</p> <p>The mode is switched between input and output with the IOS instruction, and data is input with the INR instruction and output with the OUTR instruction.</p> <p>The SPB, RPB, TPT, and TPF instruction cannot be used with these ports.</p> <p>Input is disabled and the pins go to the high-impedance state in Backup mode.</p> <p>These ports are set up as general-purpose input ports after a power on reset.</p>	
TEST1 TEST2	99 2		<p>LSI test pins.</p> <p>These pins must be connected to GND.</p>	

- Specifications of any and all SANYO Semiconductor products described or contained herein stipulate the performance, characteristics, and functions of the described products in the independent state, and are not guarantees of the performance, characteristics, and functions of the described products as mounted in the customer's products or equipment. To verify symptoms and states that cannot be evaluated in an independent device, the customer should always evaluate and test devices mounted in the customer's products or equipment.
- SANYO Semiconductor Co., Ltd. strives to supply high-quality high-reliability products. However, any and all semiconductor products fail with some probability. It is possible that these probabilistic failures could give rise to accidents or events that could endanger human lives, that could give rise to smoke or fire, or that could cause damage to other property. When designing equipment, adopt safety measures so that these kinds of accidents or events cannot occur. Such measures include but are not limited to protective circuits and error prevention circuits for safe design, redundant design, and structural design.
- In the event that any or all SANYO Semiconductor products (including technical data, services) described or contained herein are controlled under any of applicable local export control laws and regulations, such products must not be exported without obtaining the export license from the authorities concerned in accordance with the above law.
- No part of this publication may be reproduced or transmitted in any form or by any means, electronic or mechanical, including photocopying and recording, or any information storage or retrieval system, or otherwise, without the prior written permission of SANYO Semiconductor Co., Ltd.
- Any and all information described or contained herein are subject to change without notice due to product/technology improvement, etc. When designing equipment, refer to the "Delivery Specification" for the SANYO Semiconductor product that you intend to use.
- Information (including circuit diagrams and circuit parameters) herein is for example only; it is not guaranteed for volume production. SANYO Semiconductor believes information herein is accurate and reliable, but no guarantees are made or implied regarding its use or any infringements of intellectual property rights or other rights of third parties.

This catalog provides information as of February, 2006. Specifications and information herein are subject to change without notice.