



EMIF02-USB01

IPAD™

2 LINES EMI FILTER INCLUDING ESD PROTECTION

MAIN APPLICATION

- ESD protection and EMI filtering for USB port.

DESCRIPTION

The EMIF02-USB01 is a highly integrated array designed to suppress EMI / RFI noise for USB port filtering.

The EMIF02-USB01 flip-chip packaging means the package size is equal to the die size. That's why EMIF02-USB01 is a very small device.

Additionally, this filter includes an ESD protection circuitry which prevents the protected device from destruction when subjected to ESD surges up to 15 kV.

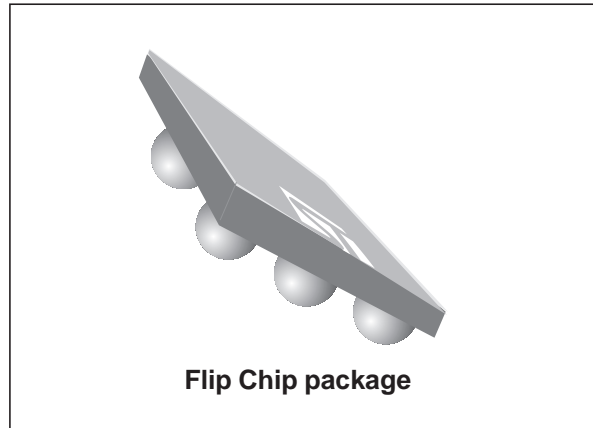

BENEFITS

- 2 lines low-pass-filter + 2 lines ESD protection
- High efficiency in EMI filtering
- Very low PCB space consuming: 2.5 mm²
- Very thin package: 0.65 mm
- High efficiency in ESD suppression (IEC61000-4-2 level 4)
- High reliability offered by monolithic integration
- High reducing of parasitic elements through integration & wafer level packaging.

COMPLIES WITH THE FOLLOWING STANDARDS :

IEC61000-4-2 level 4

15kV (air discharge)
8 kV (contact discharge)

on input & output pins.

PIN CONFIGURATION

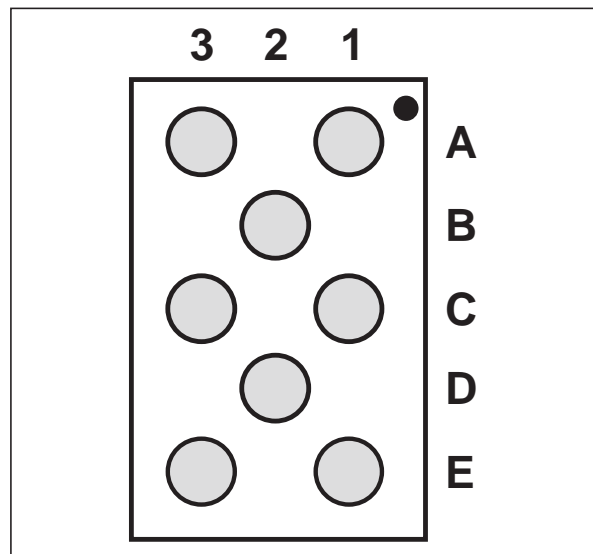

™ : ASD is trademark of STMicroelectronics.

SCHEMATIC

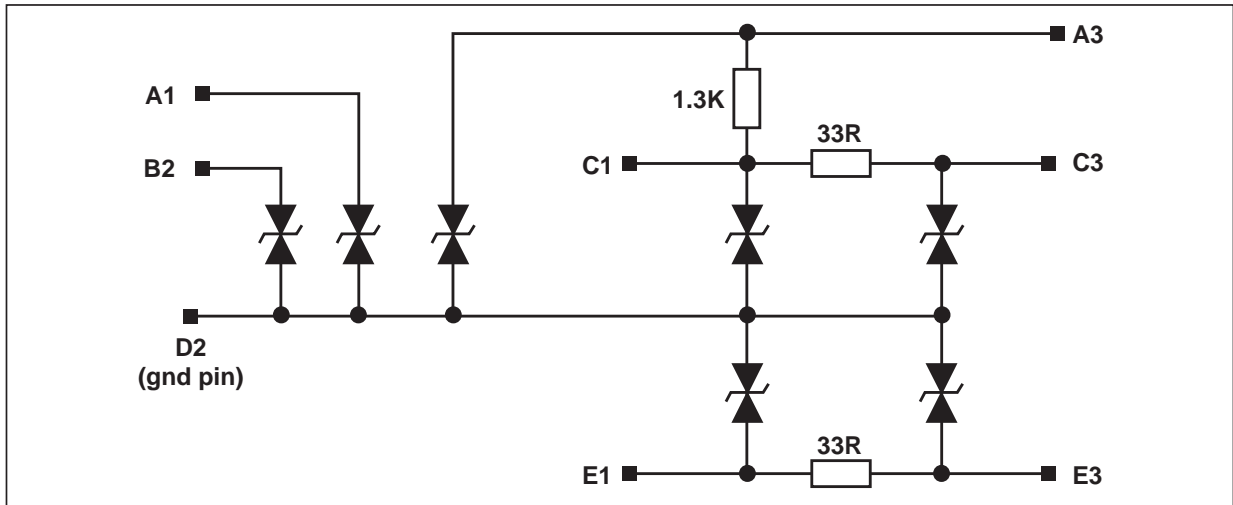

Fig. 1: Filtering behavior

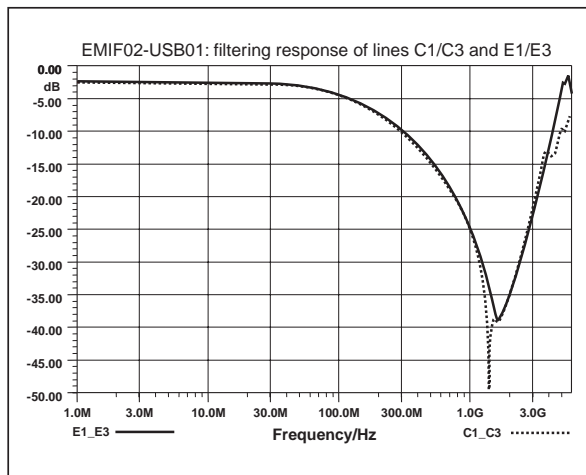

Fig. 2: ESD response to IEC61000-4-2 Level 4

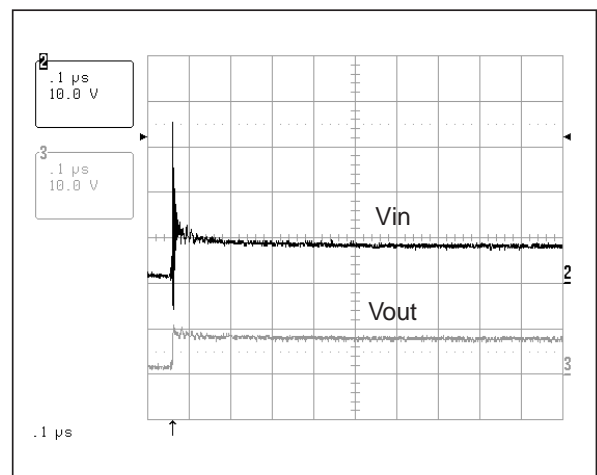

Fig. 3: Capacitance versus reverse applied voltage

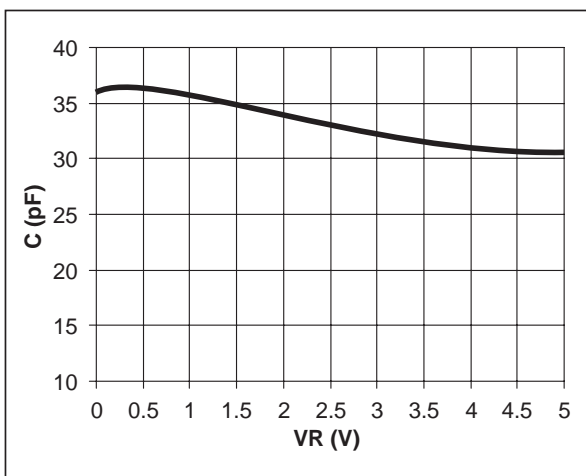
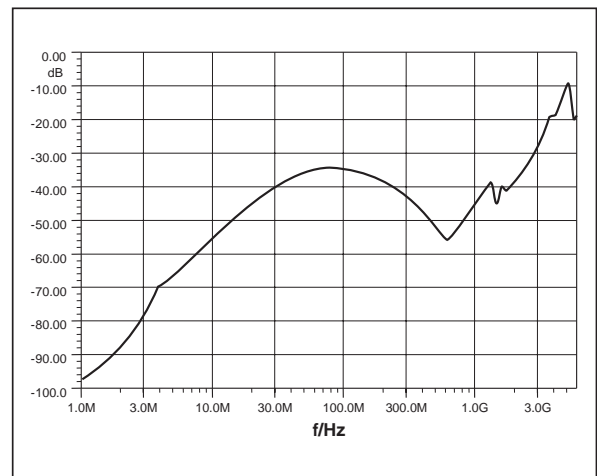

Fig. 4: Digital crosstalk



ABSOLUTE MAXIMUM RATINGS ($T_{amb} = 25\text{ }^{\circ}\text{C}$)

Symbol	Parameter and test conditions	Value	Unit
V_{PP}	ESD discharge IEC61000-4-2, air discharge ESD discharge IEC61000-4-2, contact discharge	15 8	kV
T_j	Junction temperature	125	$^{\circ}\text{C}$
T_{op}	Operating temperature range	-40 to +85	$^{\circ}\text{C}$
T_{stg}	Storage temperature range	-55 to +150	$^{\circ}\text{C}$

ELECTRICAL CHARACTERISTICS ($T_{amb} = 25\text{ }^{\circ}\text{C}$)

Symbol	Parameter
V_{BR}	Breakdown voltage
I_{RM}	Leakage current @ V_{RM}
V_{RM}	Stand-off voltage
V_{CL}	Clamping voltage
R_d	Dynamic impedance
I_{PP}	Peak pulse current

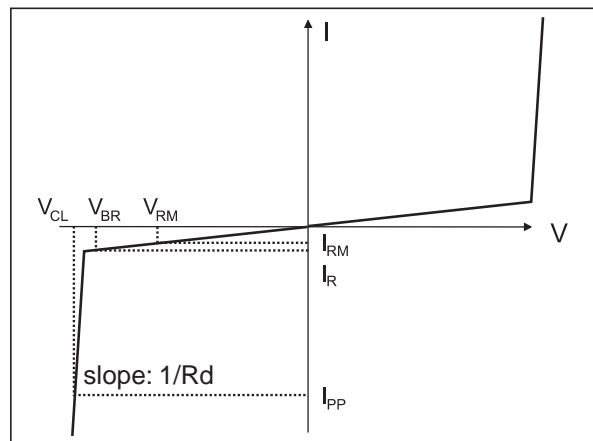

Symbol	Test conditions	Min.	Typ.	Max.	Unit
V_{BR}	$I_R = 1\text{ mA}$	6			V
I_{RM}	$V_{RM} = 3\text{ V}$		0.1	0.5	μA
C_{line}	@ 0V		40	45	pF
R_1, R_2	Tolerance $\pm 5\%$		33.0		Ω
R_3	Tolerance $\pm 5\%$		1.30		k Ω

APLAC MODELS

Fig. 5: Aplac model of resistors

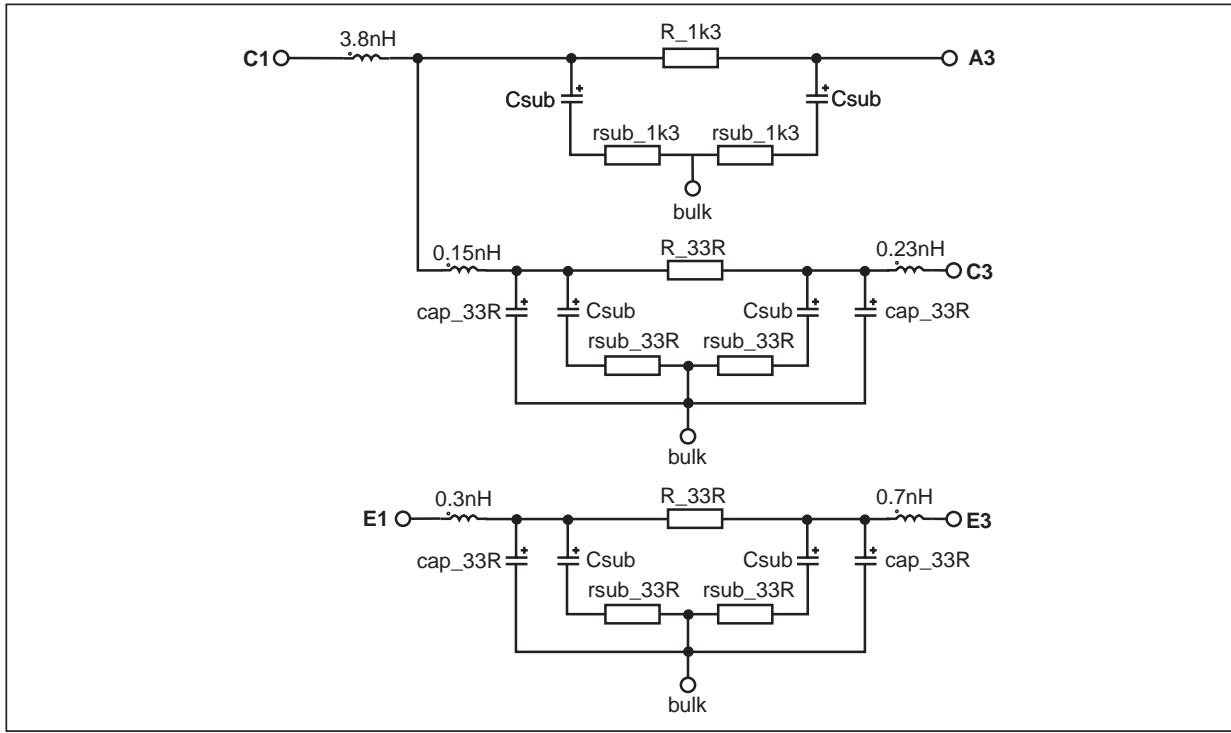

Fig. 6: Aplac model of the diodes

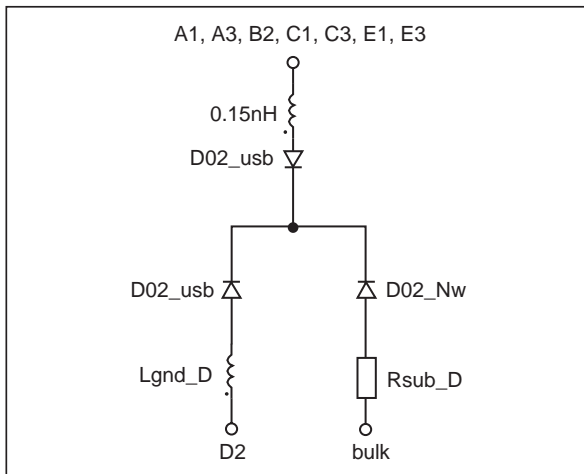
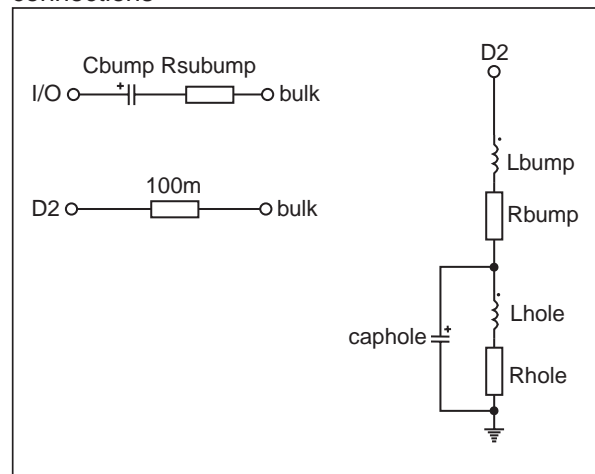

Fig. 7: Aplac model of bumps & ground connections



EMIF02-USB01

Fig. 8: Aplac model parameters

aplacvar R_33R 33.9	Model D02_Nw	Model D02_usb
aplacvar cap_33R 1.2pF	BV=100	BV=16
	IBV=1m	IBV=1m
aplacvar R_1k3 1.3k	CJO=6.8p	CJO=Cz
	M=0.3333	M=0.3333
aplacvar Cz29pF	RS=2	RS=2
aplacvar Rsub_D 100	VJ=0.6	VJ=0.6
	TT=100n	TT=100n
aplacvar Csub0.3pF		
aplacvar Rsub_33R 15		
aplacvar Rsub_1k3 50		
aplacvar lhole 10pH		
aplacvar Rhole 400m		
aplacvar Caphole0.4pF		
aplacvar Lgnd_D 150pH		
aplacvar Lbump 50pH		
aplacvar Rbump 50m		
aplacvar Cbump 1.5pF		
aplacvar Rsubump 150		

Fig. 9: Comparison between Aplac simulations and measured frequency response.

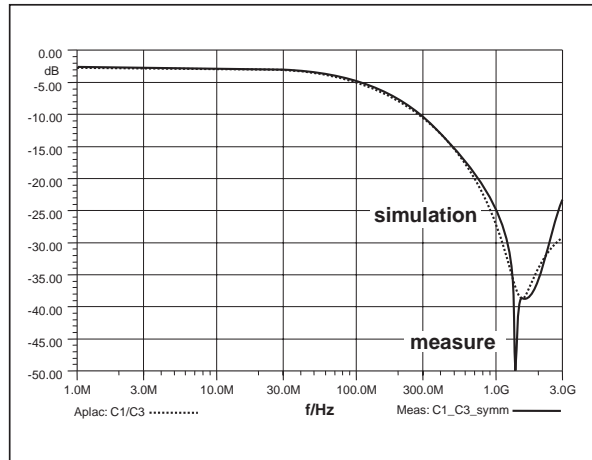

ORDER CODE

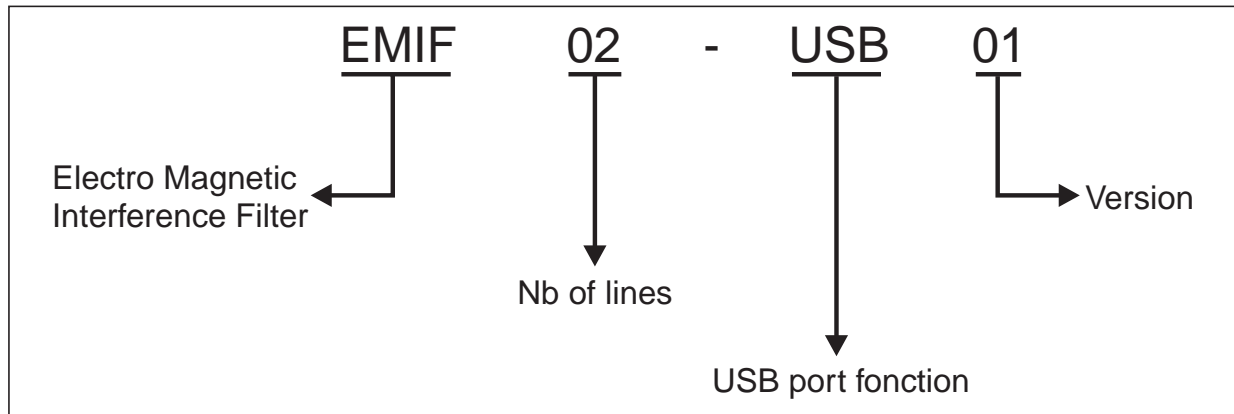

PACKAGE MECHANICAL DATA

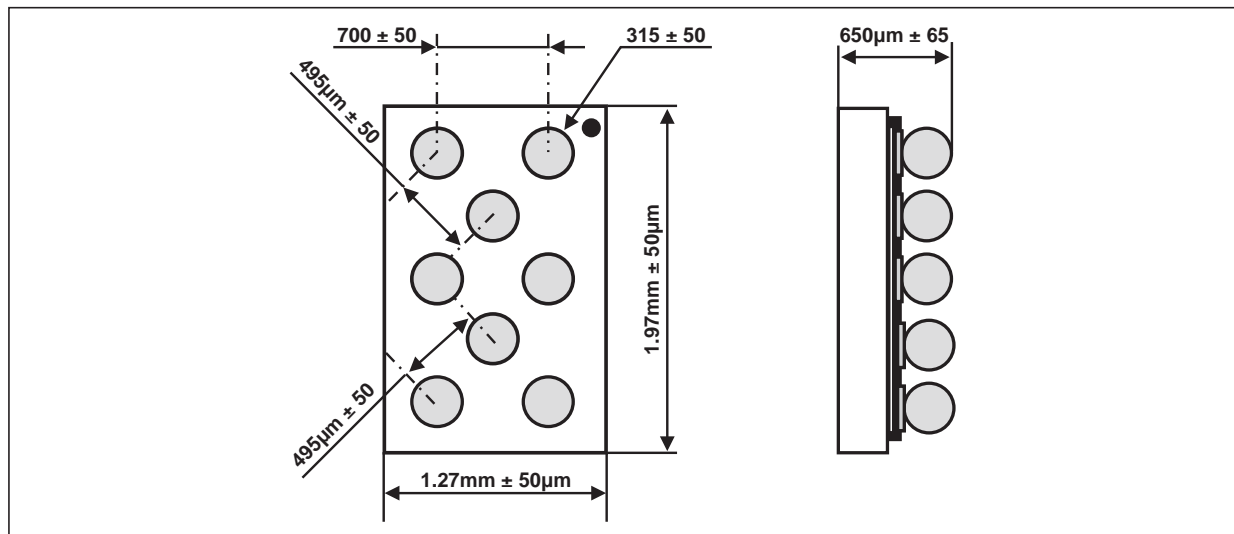

MARKING

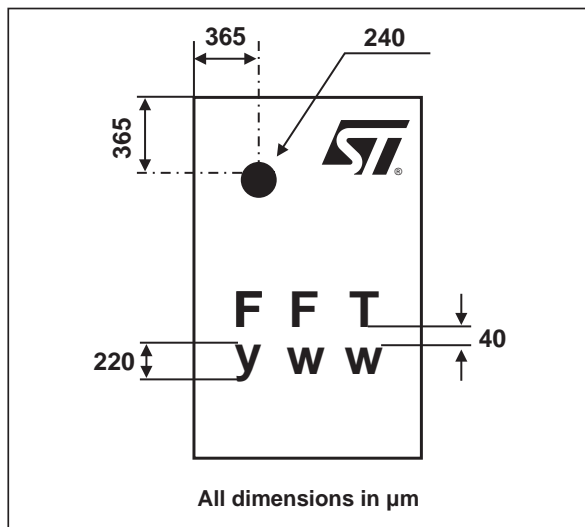

PACKING

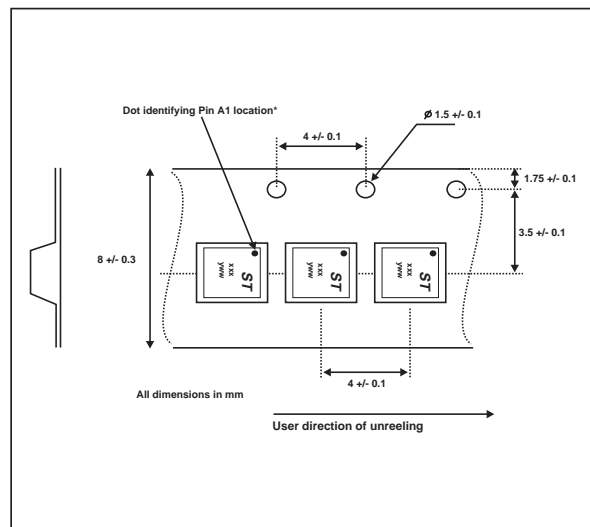

OTHER INFORMATION

Ordering code	Marking	Package	Weight	Base qty	Delivery mode
EMIF02-USB01	FFT	Flip Chip	3.35 mg	5000	Tape & reel (7")

Note: More packing informations are available in the application note AN1235: "Flip-Chip CSP: Package description and recommendations for use"

Information furnished is believed to be accurate and reliable. However, STMicroelectronics assumes no responsibility for the consequences of use of such information nor for any infringement of patents or other rights of third parties which may result from its use. No license is granted by implication or otherwise under any patent or patent rights of STMicroelectronics. Specifications mentioned in this publication are subject to change without notice. This publication supersedes and replaces all information previously supplied.

STMicroelectronics products are not authorized for use as critical components in life support devices or systems without express written approval of STMicroelectronics.

The ST logo is a registered trademark of STMicroelectronics

© 2003 STMicroelectronics - Printed in Italy - All rights reserved.

STMicroelectronics GROUP OF COMPANIES

Australia - Brazil - Canada - China - Finland - France - Germany
 Hong Kong - India - Israel - Italy - Japan - Malaysia - Malta - Morocco - Singapore
 Spain - Sweden - Switzerland - United Kingdom - United States.

<http://www.st.com>