



11 Schematic Diagrams

* This Document can not be used without Samsung's authorization.

11-1-1 PU17IS Main Part Schematic Diagram

ANTLIA/PERSEUS PROJECT





CAUTION

- THE AREAS MARKED WITH **A** IN THE SCHEMATIC DIAGRAM AND THE PARTS LIST DESIGNATE COMPONENT WHICH HAVE SPECIAL CHARACTERISTICS IMPORTANT FOR SAFETY AND SHOULD BE REPLACED ONLY WITH TYPES IDENTICAL TO THOSE IN THE ORIGINAL CIRCUIT OR SPECIFIED IN THE PARTS LIST, BEFORE REPLACING ANY OF THE COMPONENTS, READ CAREFULLY THE "PRODUCT SAFETY NOTICE".
- DRAWING A NUMEROUS MEASUREMENT OF THIS MONITOR MATTERS THAT DEMAND SPECIAL ATTENTION IS FOLLOWING 1)DO NOT USE YOUR INSTRUMENT BETWEEN PRIMARY GROUND (SYMBOL ) AND SECONDARY CIRCUIT. 2)DO NOT USE YOUR INSTRUMENT BETWEEN SECONDARY GROUND (SYMBOL ) AND PRIMARY CIRCUIT.

AVERTISSEMENT: "CE RECEPTEUR EST EQUIPE DE COMPOSANTS CRITIQUES POUR LA SECURITE TOUTES PIECES INDIQUEES DANS LES ZONES OMBREES DU SCHEMA SONT CRITIQUE POUR LA SECURITE DE L'APPAREIL. NE REMPLACER LE FABRICANT DONT LE FONCTIONNEMENT EST CRITIQUE QUE PAR DES PIECES RECOMMANDEES PAR LE FABRICANT CONSULTER LA NOMENCLATURE DES PIECES POUR TROUVER."

WARNING: "THIS EQUIPMENT CONTAINS SAFETY CRITICAL COMPONENTS ALL PARTS SHOWN IN THE SHADED AREAS OF THE SCHEMATIC ARE SAFETY REPLACE SAFETY CRITICAL COMPONENTS ONLY WITH MANUFACTURERS' RECOMMENDED PARTS LIST FOR EXACT REPLACEMENTS".

NOTE

- RESISTANCE IS SHOWN IN OHM K-1000, M-1000000. RATED POWER OF RESISTOR NOT NOTED IN SCHEMATIC DIAGRAM IS 1/8W.
- CAPACITANCE IS SHOWN UF AND NOT NOTED CAPACITANCE IS SHOWN PF. 1UF=1000000PF. RATED VOLTAGE OF CONDENSER NOT NOTED IN SCHEMATIC DIAGRAM IS 50V.
- ABBREVIATION AND SYMBOL.
 MO-R-METAL-OXIDE
 WW-R WIRE WOUND
 FU-R FUSIBLE
 MF-R METAL FILM
 CP-R COMPOSITION
 P-C-POLYESTER
 M-O-C MONOLYTIC
 NP-C-NP-C
 PP-C-POLYPROPYLENE
 MP-C-M-POLYESTER
 MP-C-METAL POLYPROPYLENE
 T-C-TANTALUM
 PRIMARY GROUND  SECONDARY GROUND 
- THE SECONDARY VOLTAGE IS READ WITH SSVM FROM INDICATED POINT TO SECONDARY GROUND  THE PRIMARY VOLTAGE IS READ WITH SSVM FROM INDICATED POINT TO PRIMARY GROUND 
- THIS SCHEMATIC DIAGRAM IS SUBJECT TO CHANGE WITHOUT NOTICE FOR FURTHER IMPROVEMENT.

WARNING: BEFORE SERVICING THIS CHASSIS, READ "X-RAY RADIATION PRECAUTION, SAFETY PRECAUTION, PRODUCT SAFETY NOTICE".

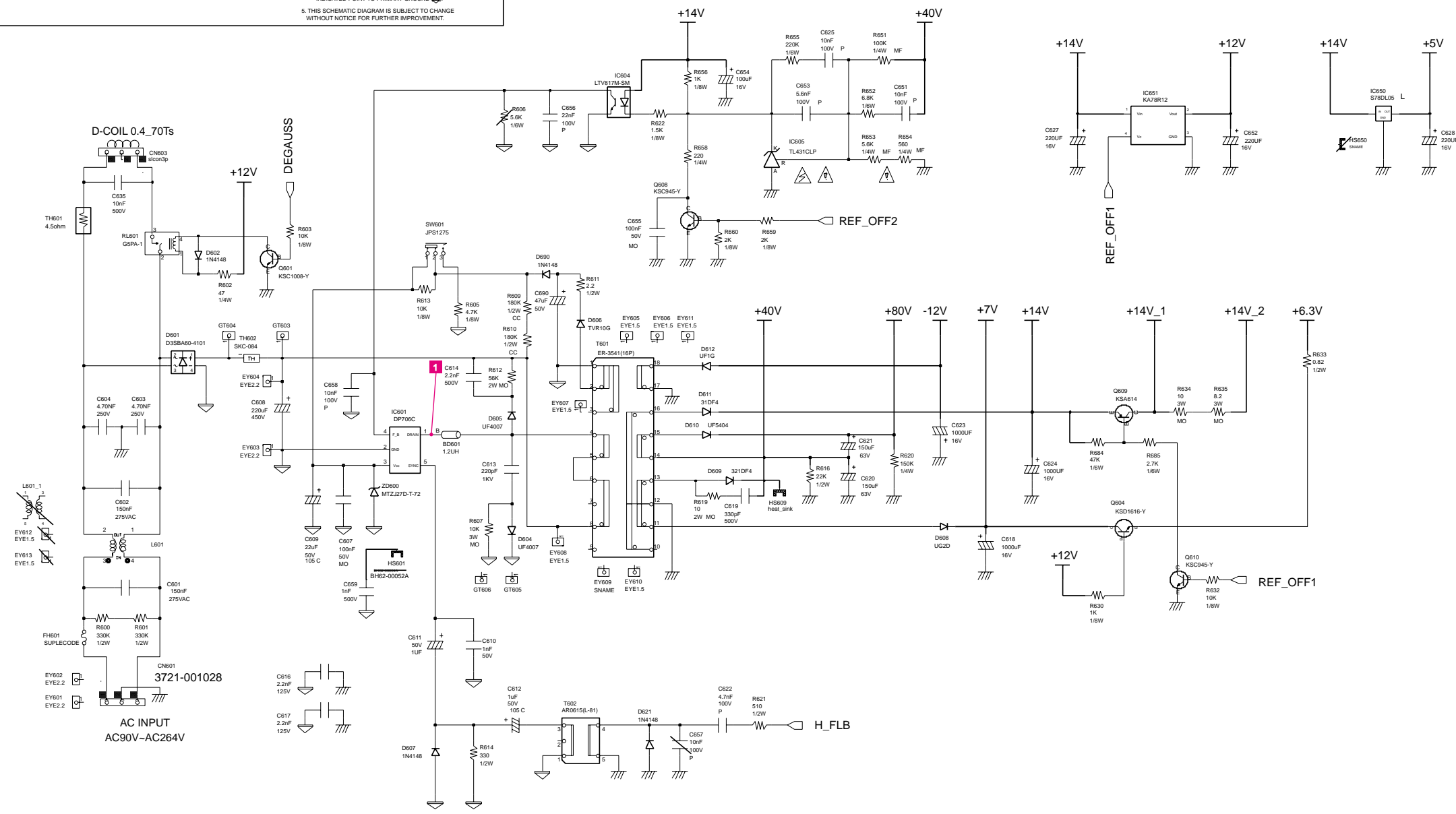

11 Schematic Diagrams

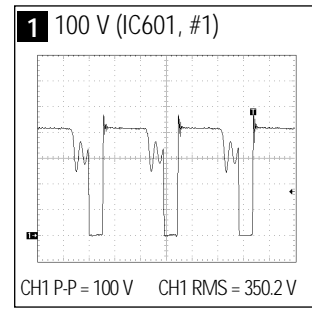

* This Document can not be used without Samsung's authorization.

11-1-2 PU17IS Main Part Schematic Diagram

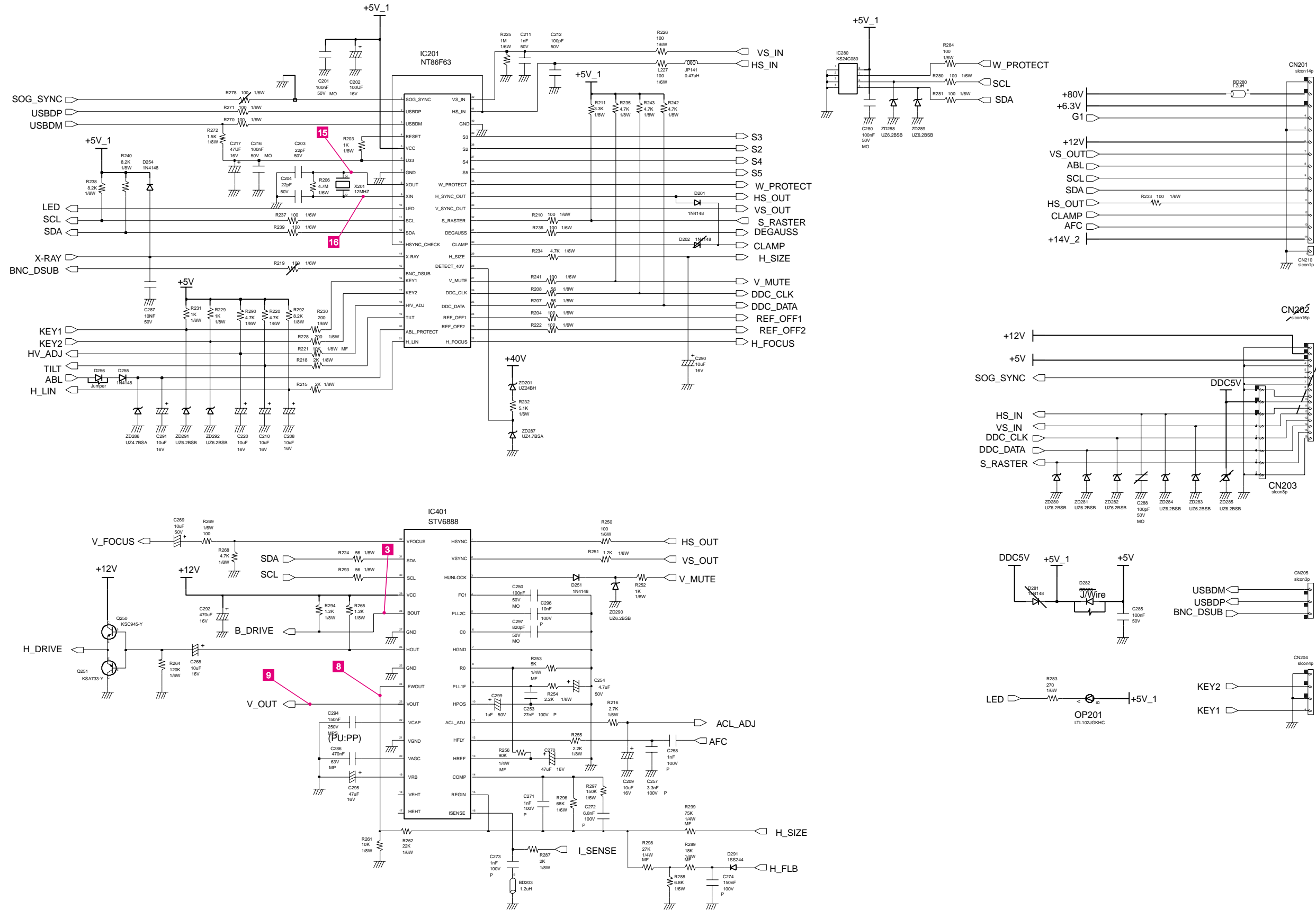

11 Schematic Diagrams

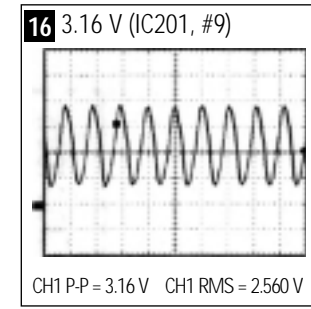
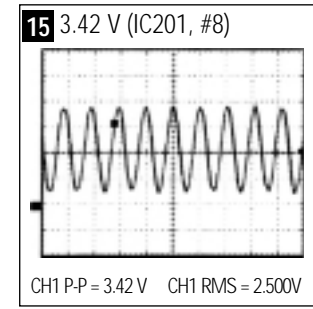
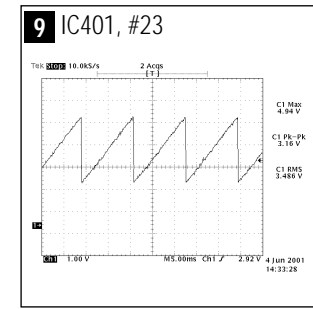
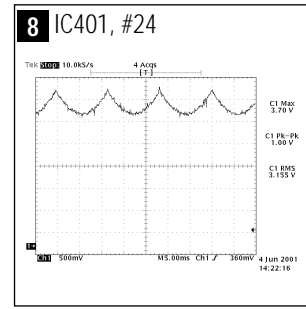
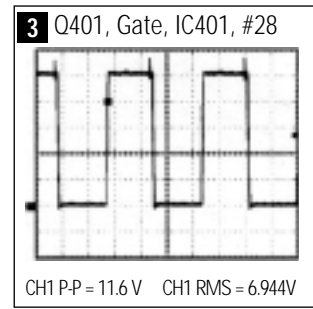

* This Document can not be used without Samsung's authorization.

11-1-3 PU17IS Main Part Schematic Diagram

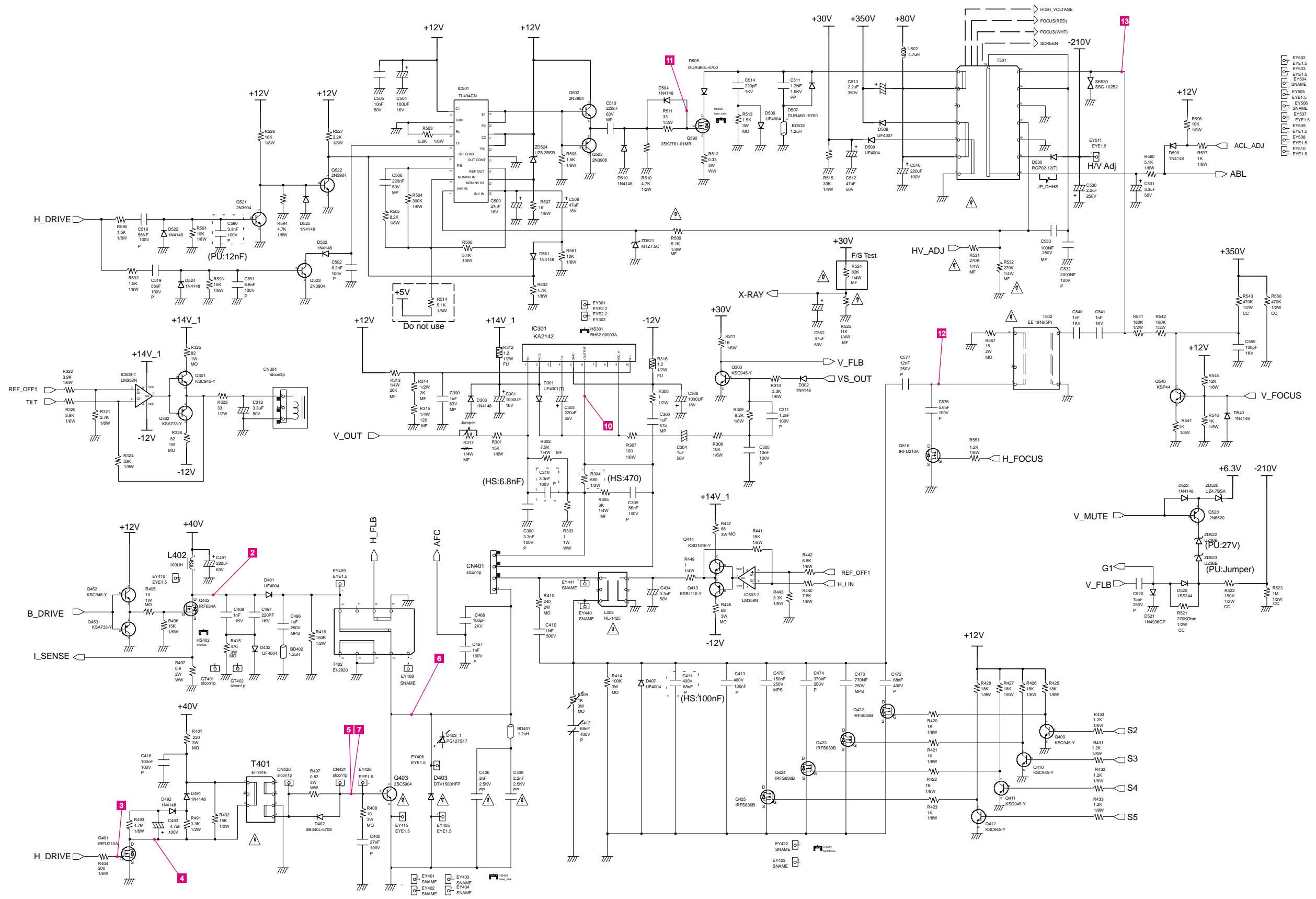

11 Schematic Diagrams

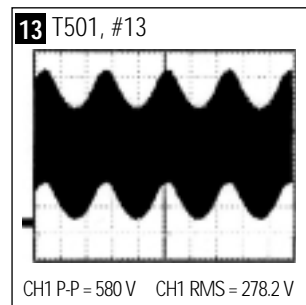
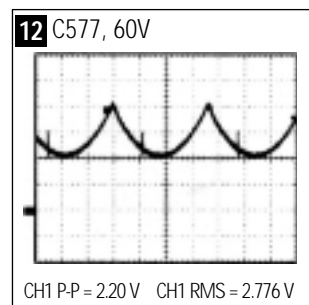
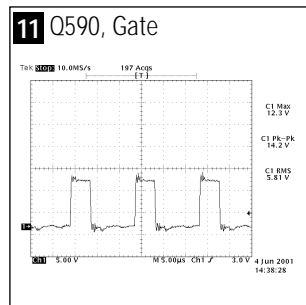
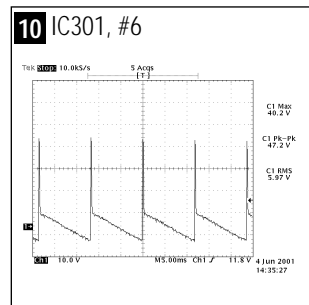
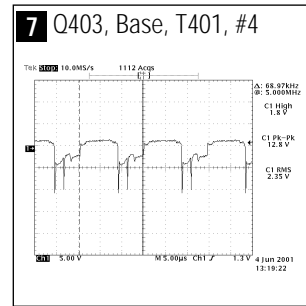
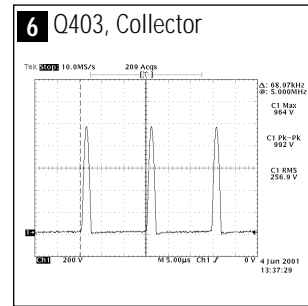
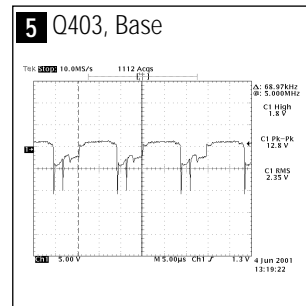
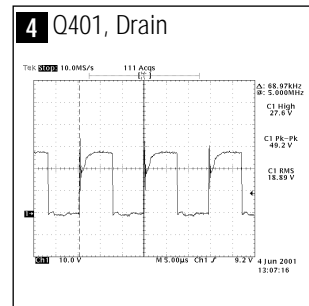
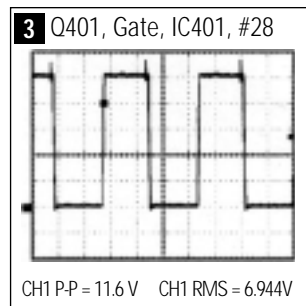
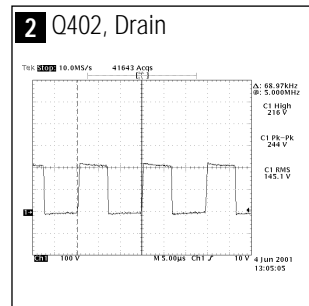

* This Document can not be used without Samsung's authorization.

11-4 PU17IS Video Part Schematic Diagram

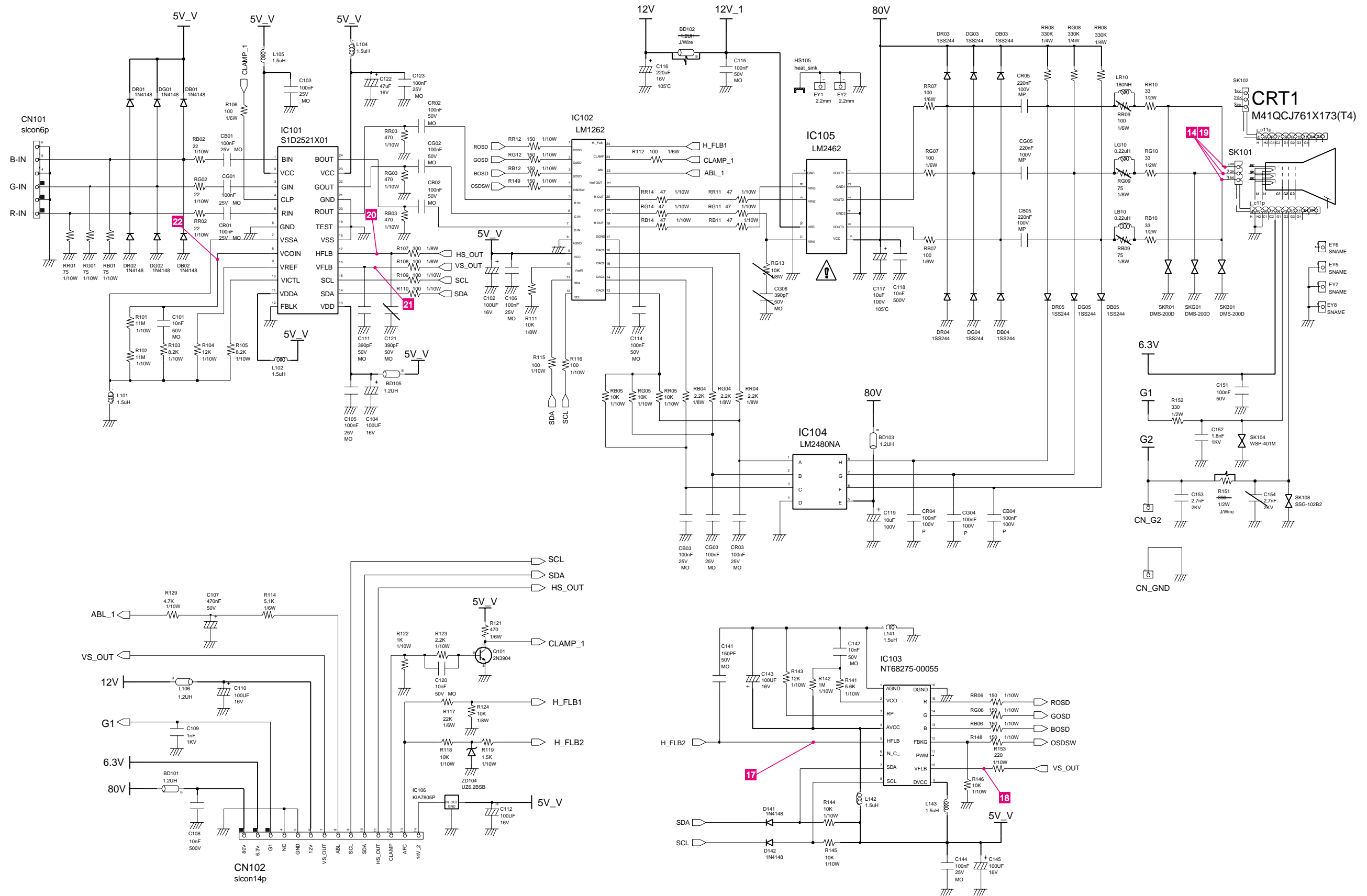

11 Schematic Diagrams

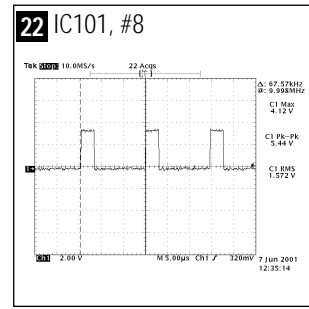
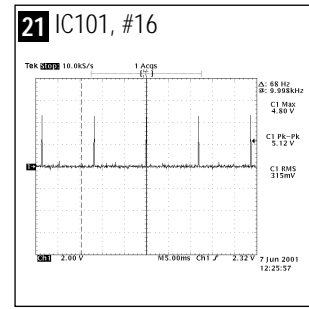
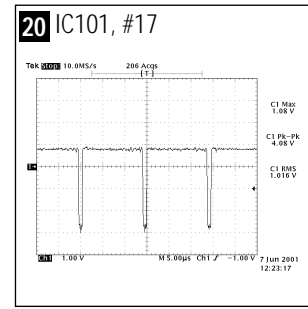
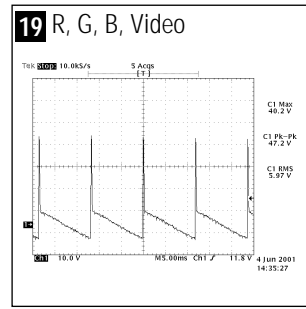
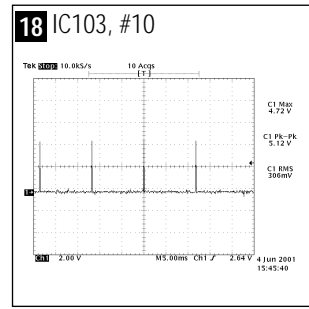
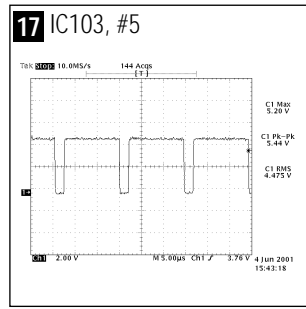
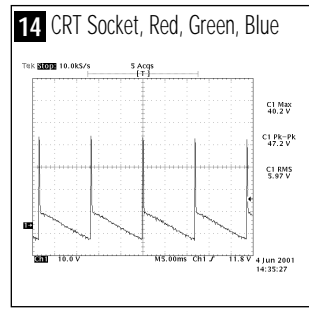

* This Document can not be used without Samsung's authorization.

11-2-1 PU19IS Main Part Schematic Diagram

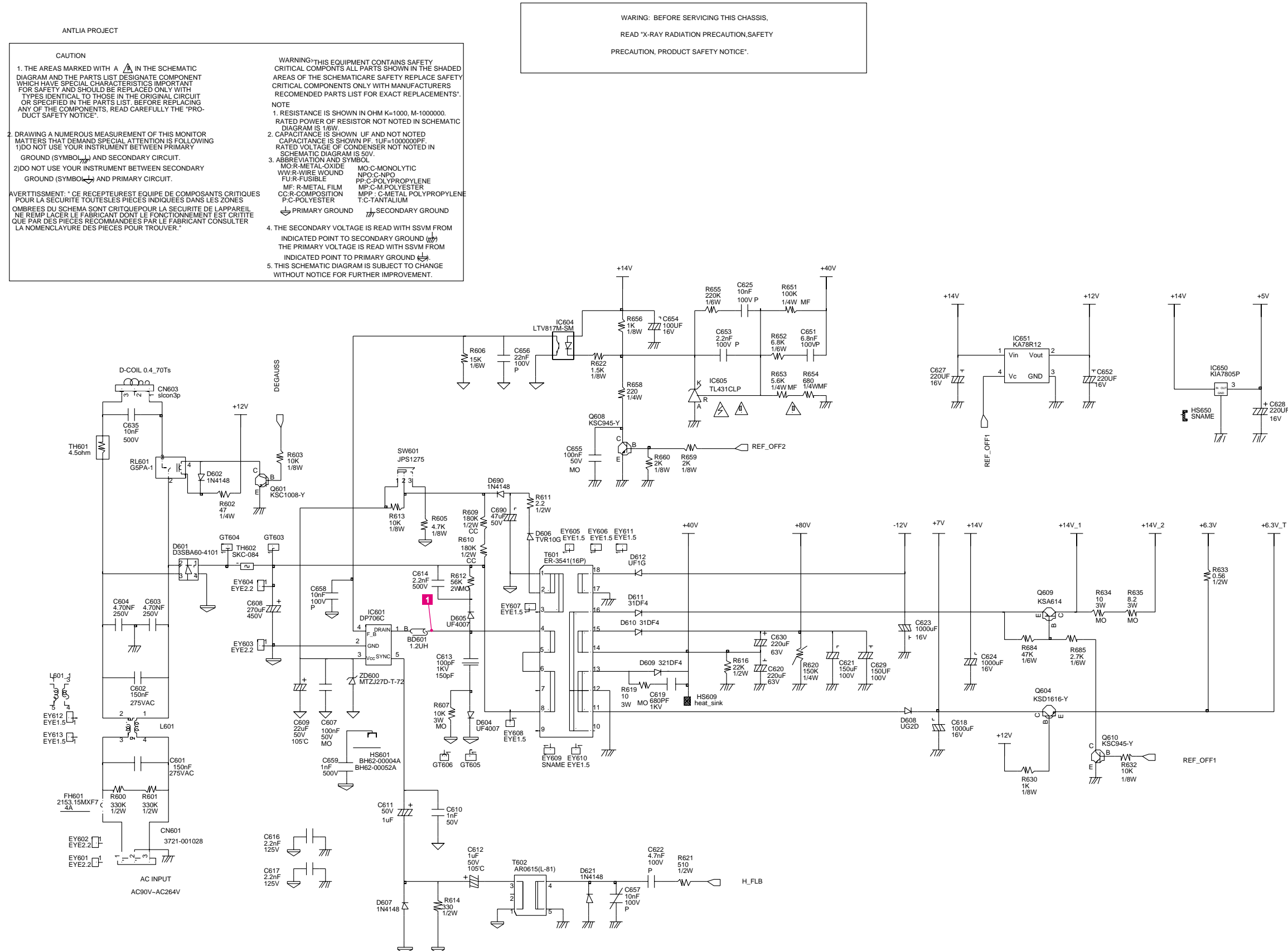

11 Schematic Diagrams

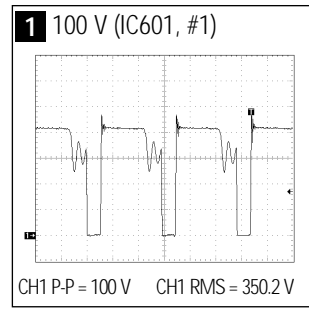

※ This Document can not be used without Samsung's authorization.

11-2-2 PU19IS Main Part Schematic Diagram

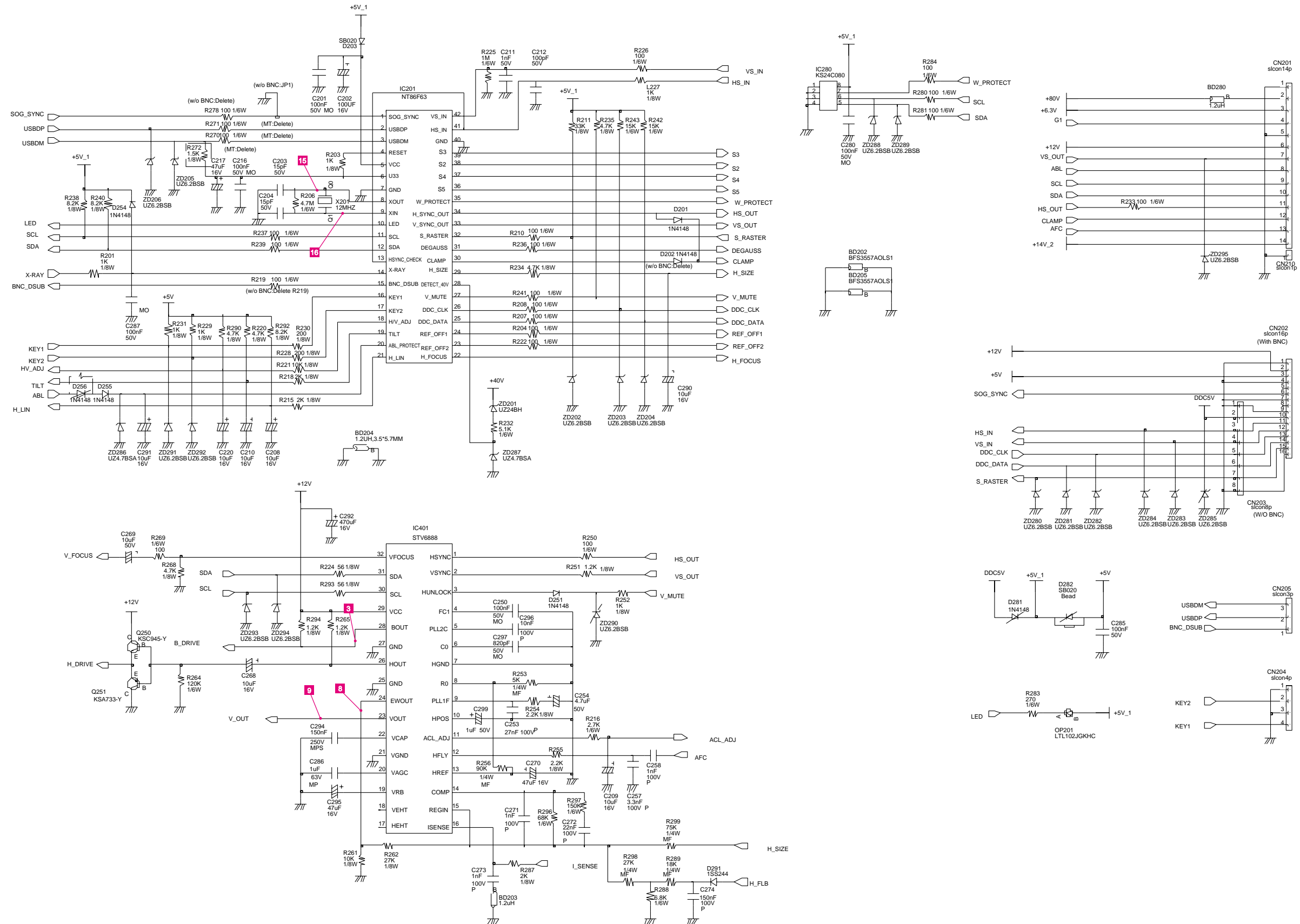

11 Schematic Diagrams

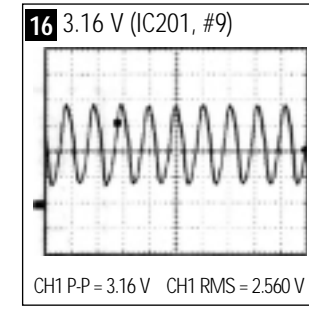
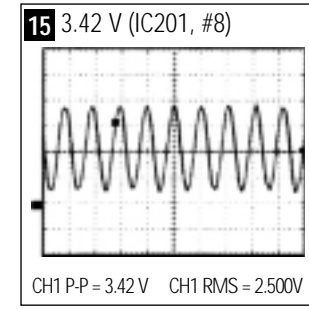
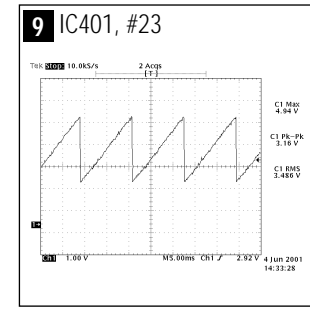
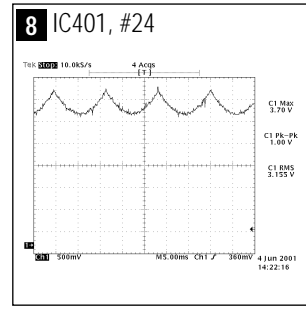
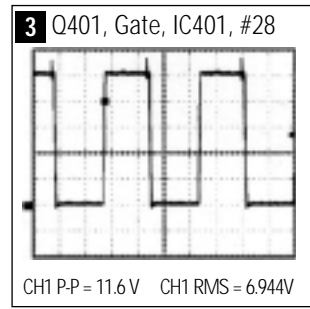

11 Schematic Diagrams

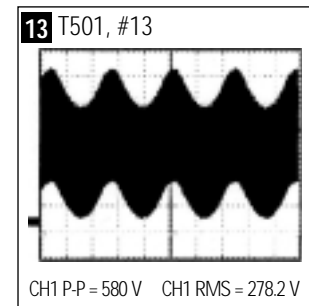
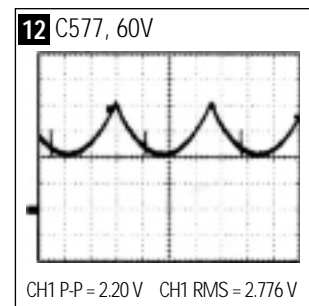
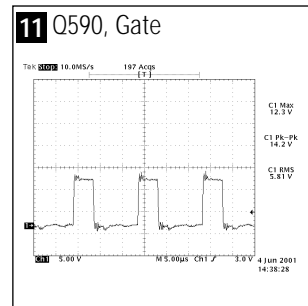
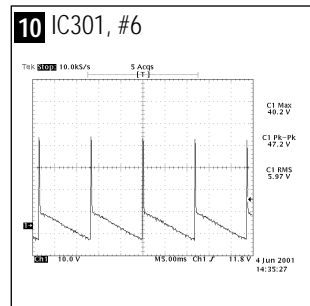
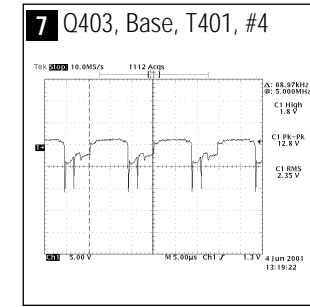
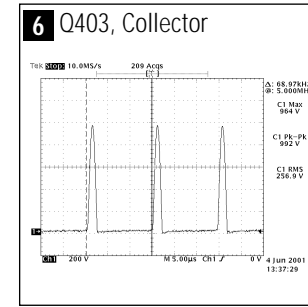
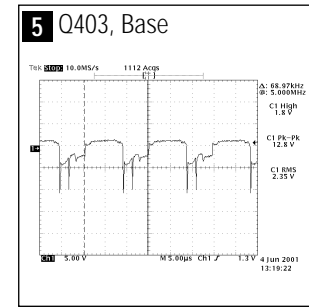
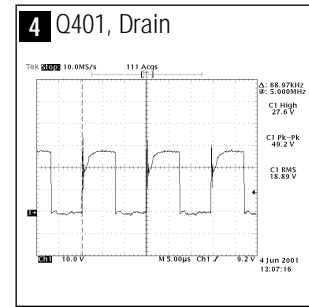
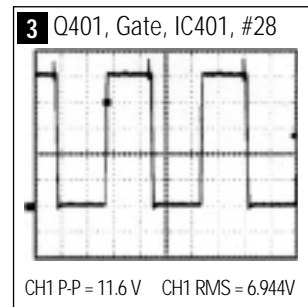
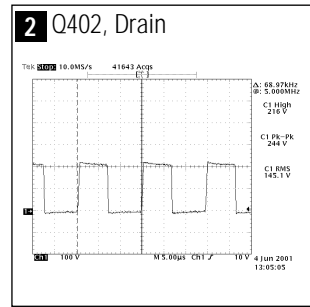

* This Document can not be used without Samsung's authorization.

11-2-4 PU19IS Video Part Schematic Diagram

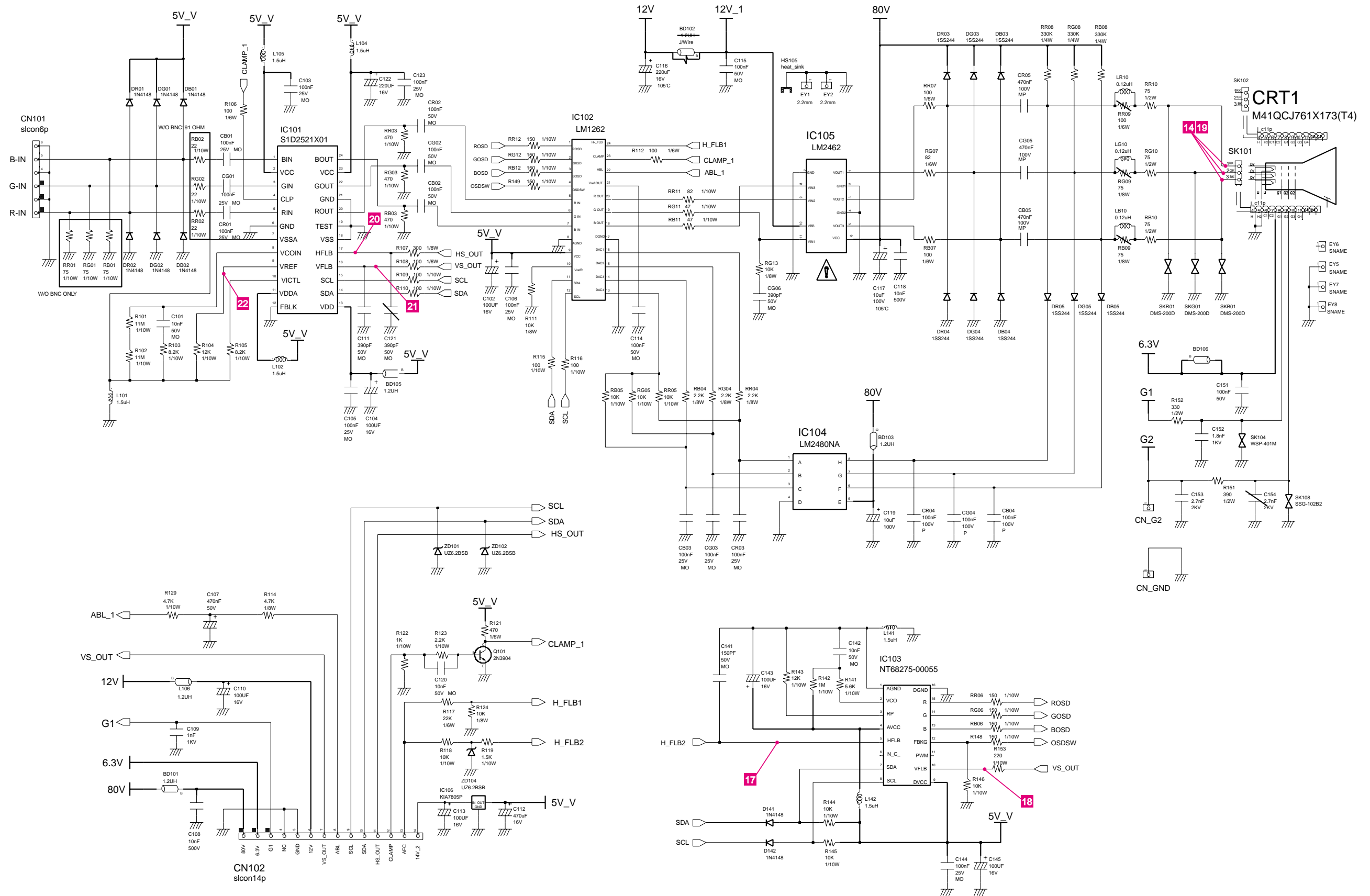

11 Schematic Diagrams

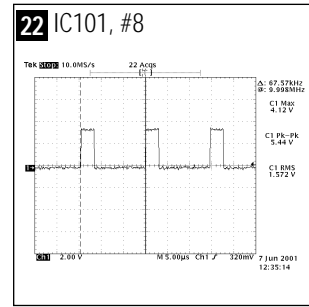
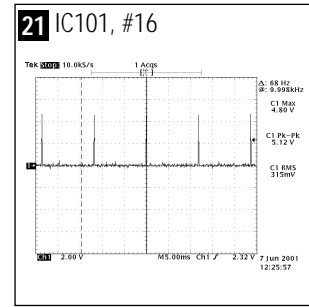
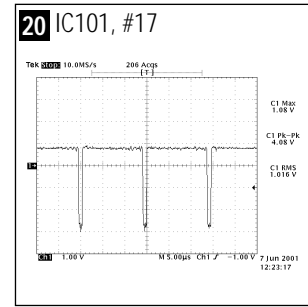
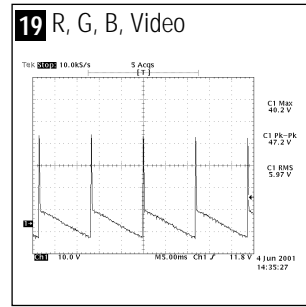
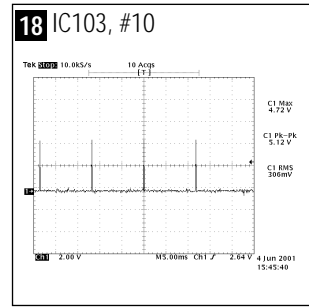
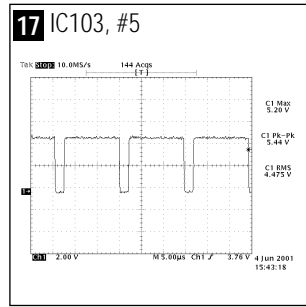
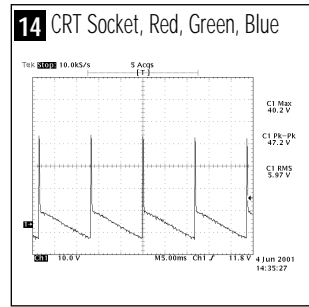

* This Document can not be used without Samsung's authorization.

11-2-5 PU19IS BNC Part Schematic Diagram

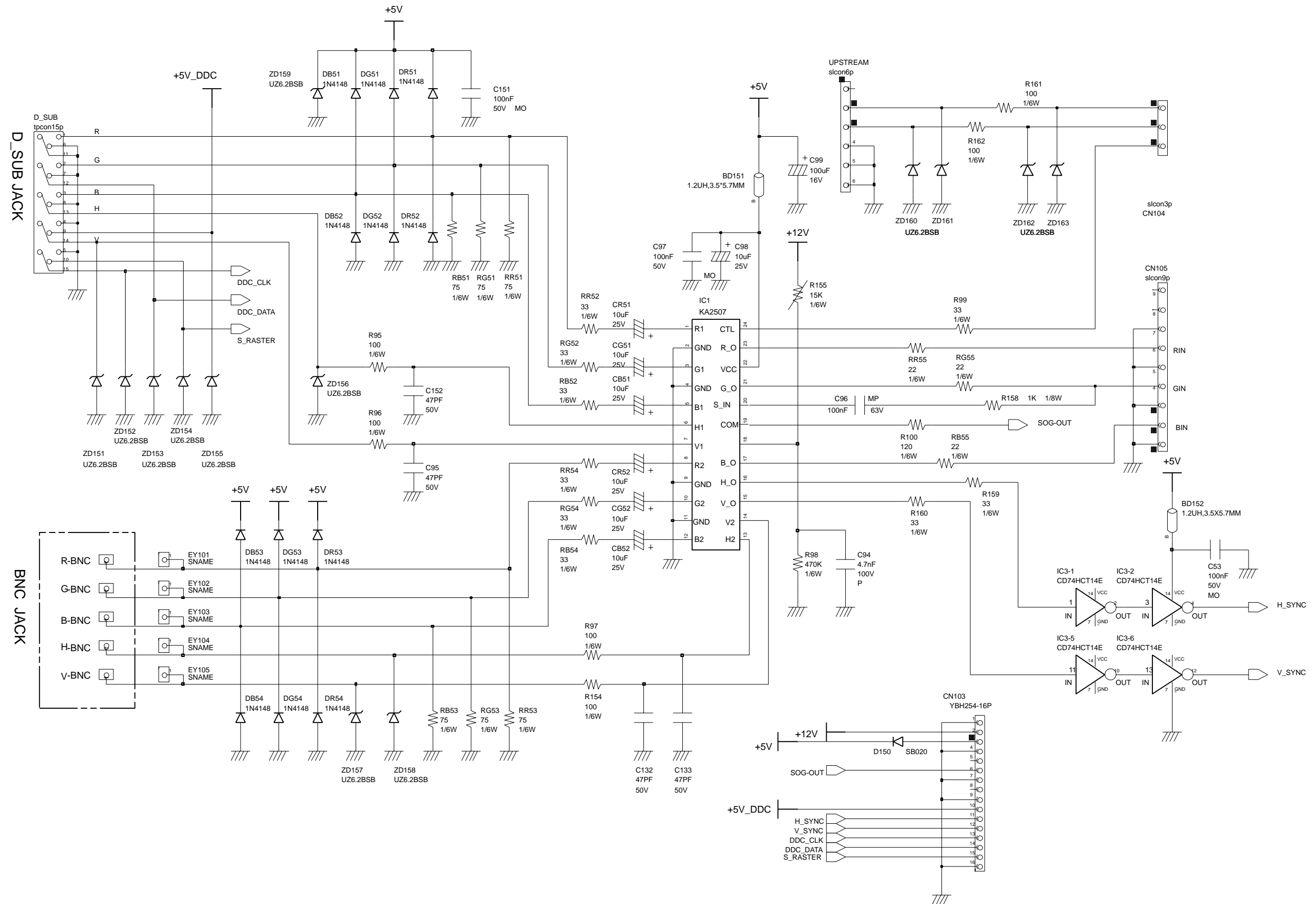

Memo