

7. Schematic Diagram

7-1. Circuit Descriptions

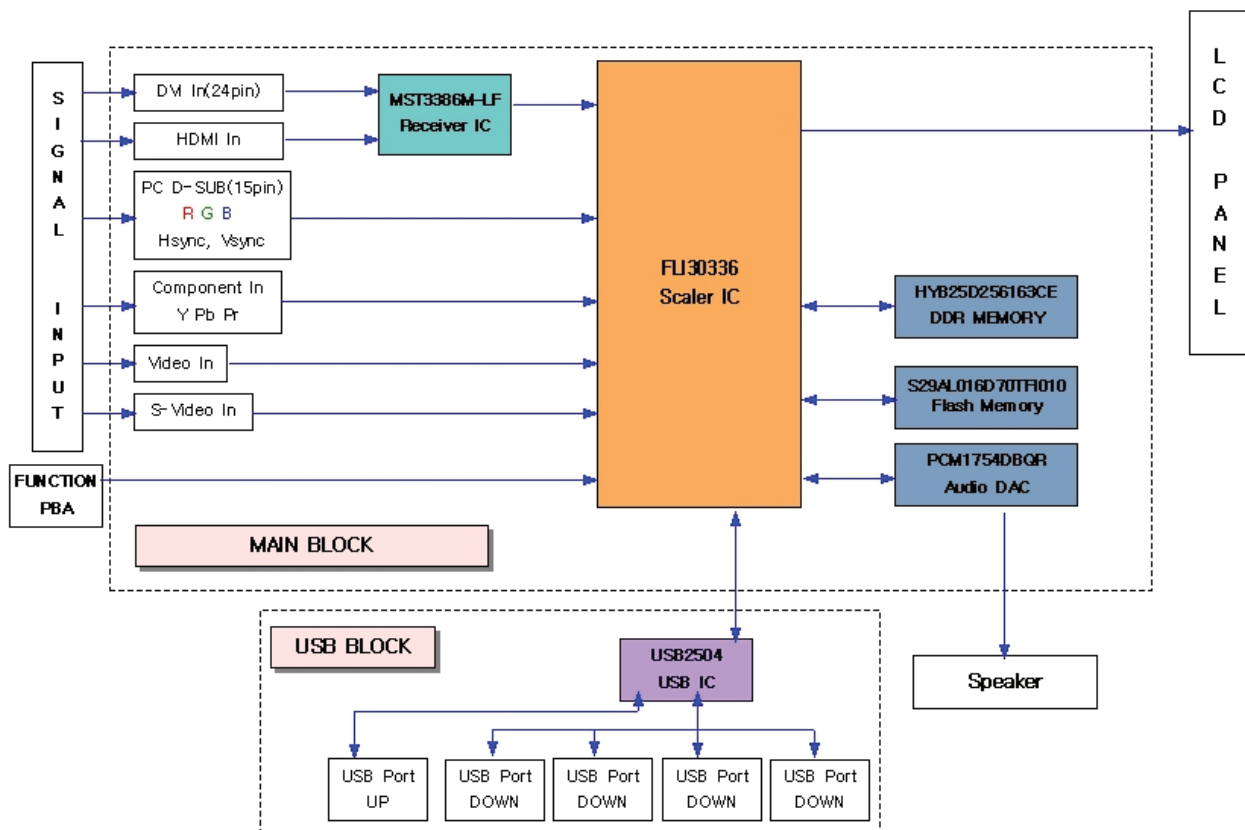

Location	Part Name	Function
Scaler	FLI30336	Scaler Integrate ADC and TMDS, Scaling part, Controller,
RECEIVER IC	MST3386M	This chip receives DVI and HDMI signal from the source and decodes signal to scaler needed.
DDR MEMORY	HYB25D256163CE	DDR memory Save frame information that SCALER needed .
FLASH MEMORY	S29AL016D70TFI010	Flash memory save information that SCALER needed. Program update is possible through the Firmware.
AUDIO DAC	PCM1754DBQR	This chip converts HDMI digital audio signal to analog signal for speaker.
USB IC	USB2504	This chip is used for 4 USB Hub.

7-2. Schematic Diagram

7-2-1 HDMI, DVI, Analog Input Block

This Document can not be used without Samsung's authorization.

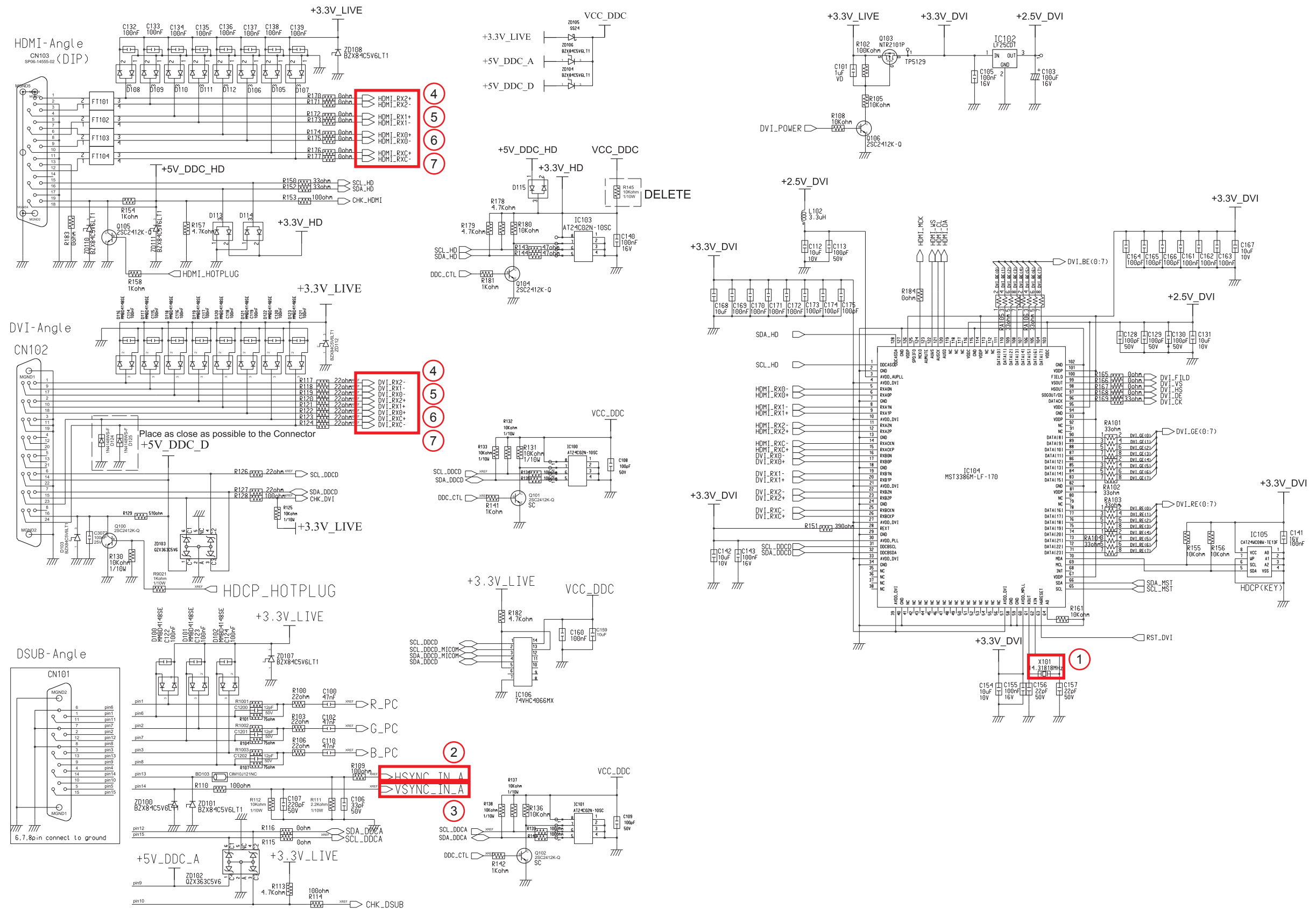

1

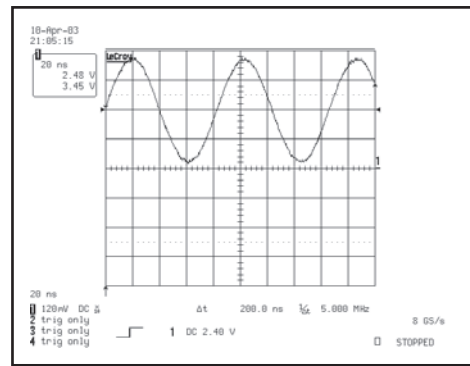

2

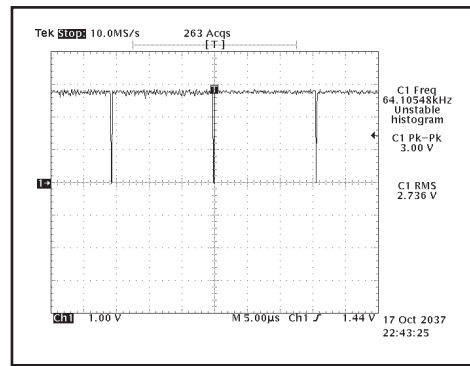

3

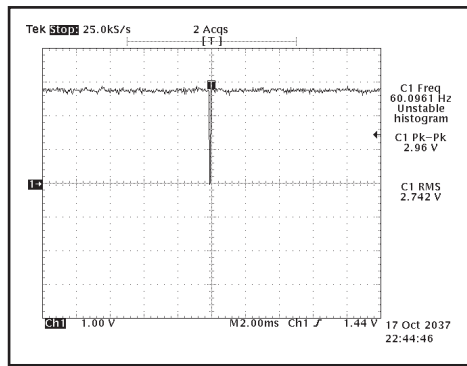

4

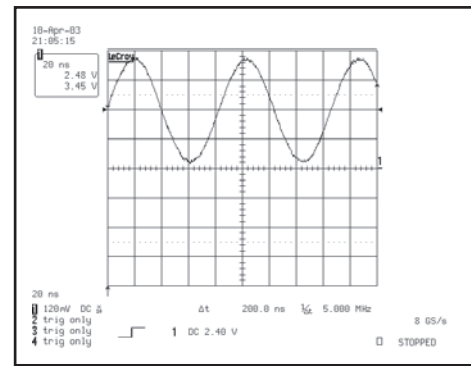

5

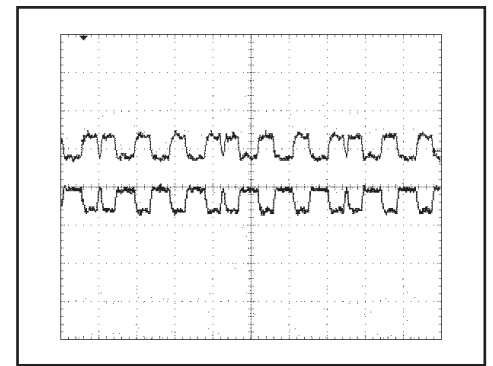

6

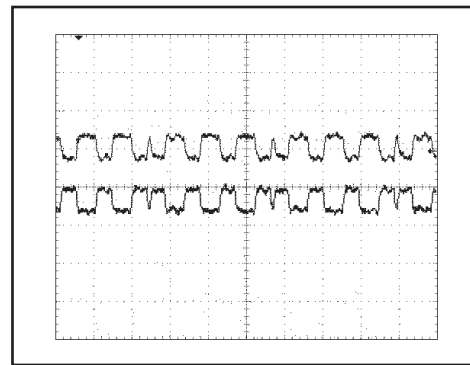

7

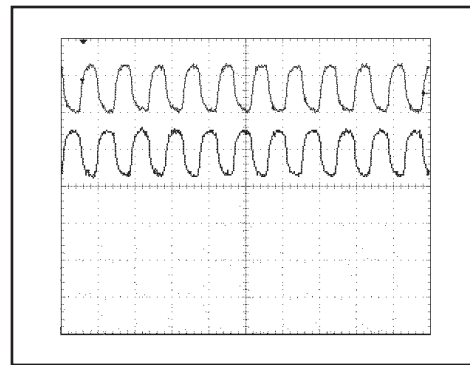

7-2-3 Component, AV, S-Video Input Block

This Document can not be used without Samsung's authorization.

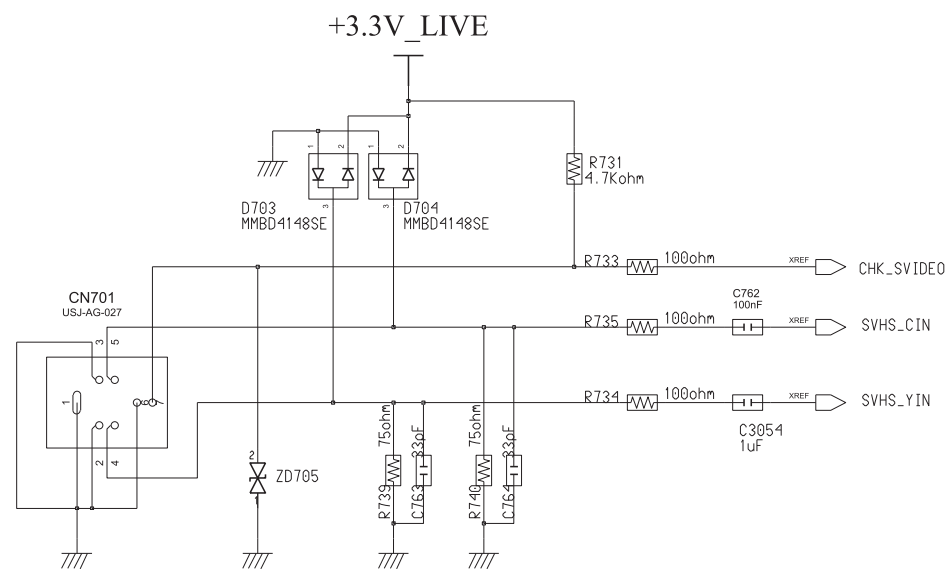
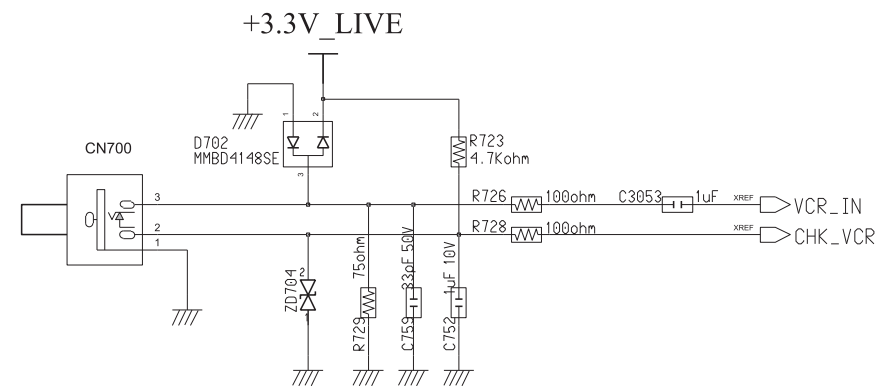
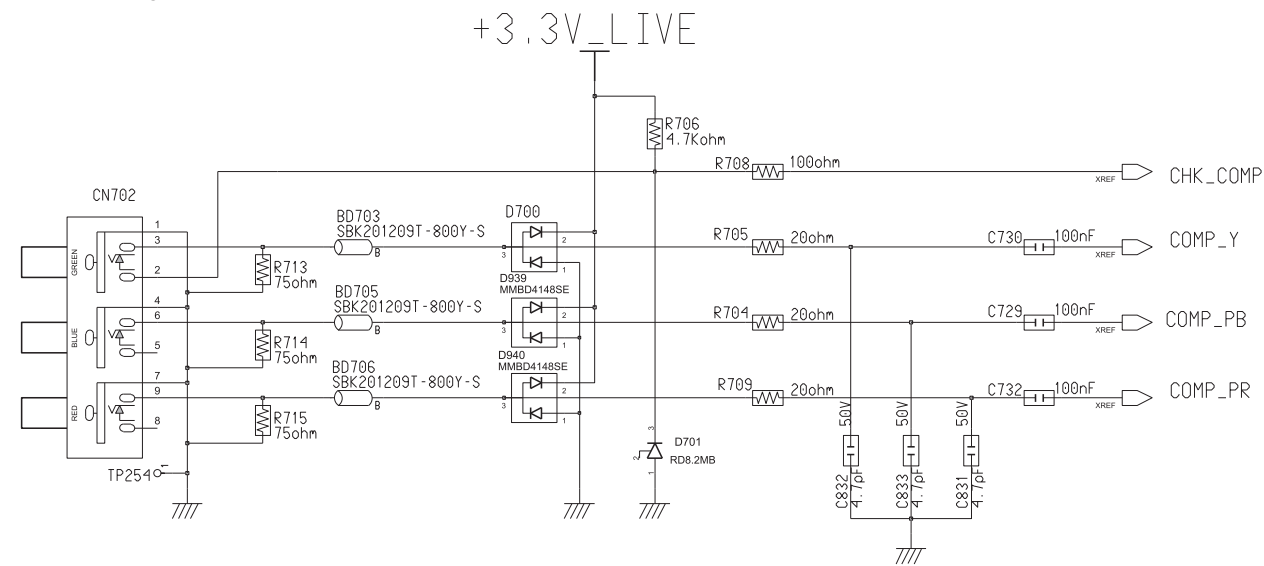

9

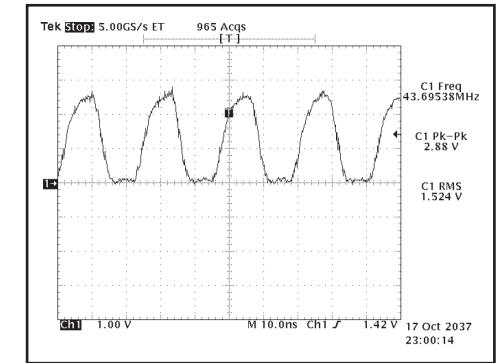

7-2-4 USB Hub Block

This Document can not be used without Samsung's authorization.

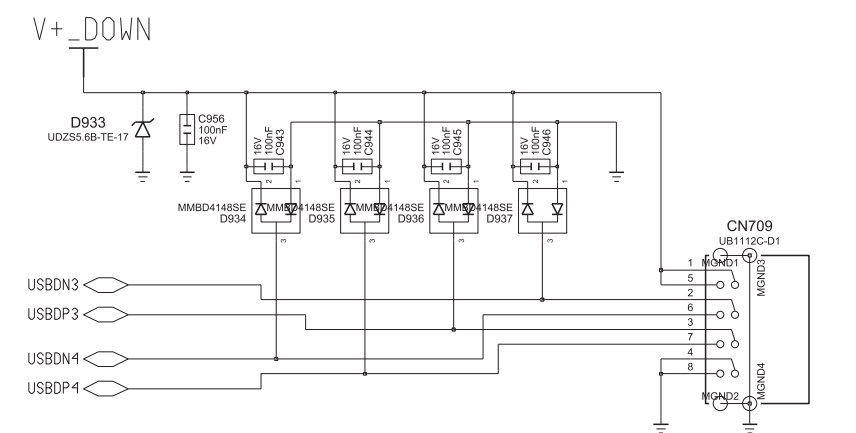
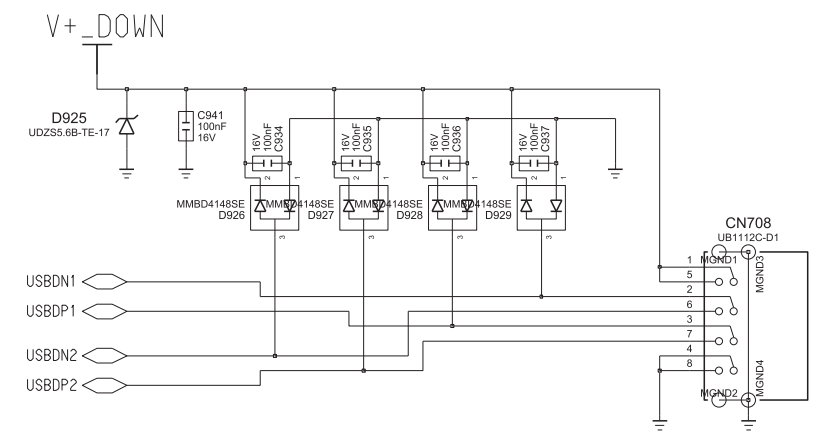
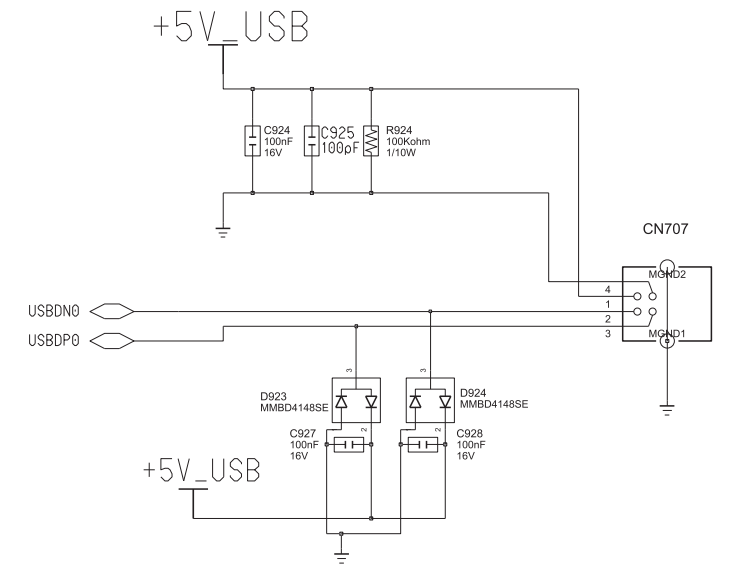
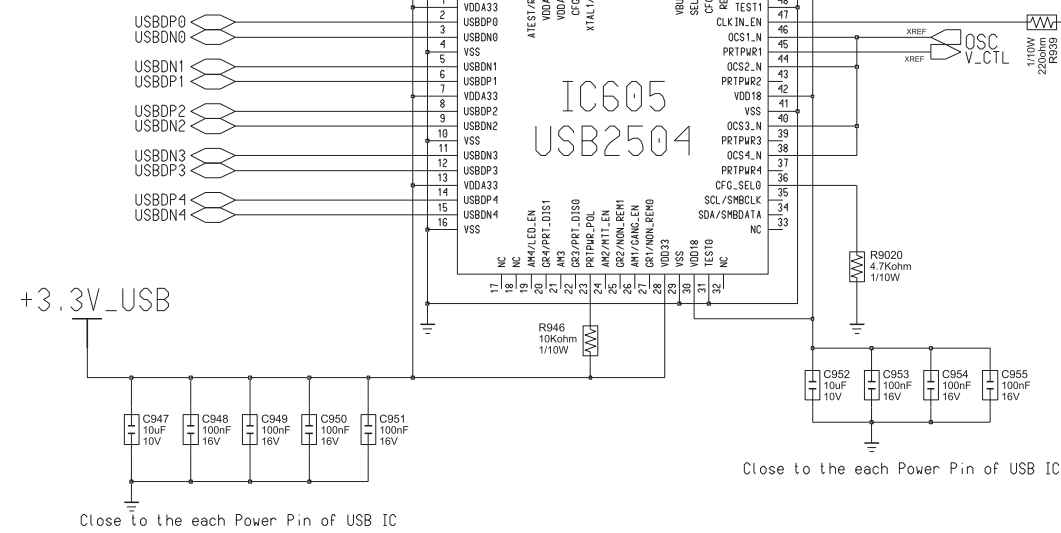
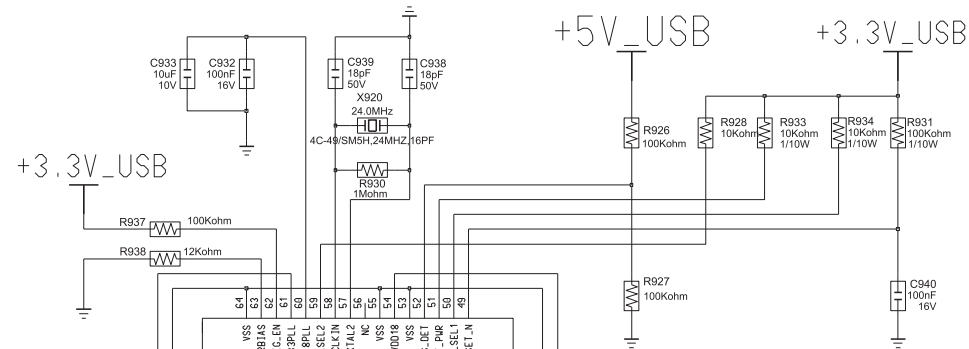
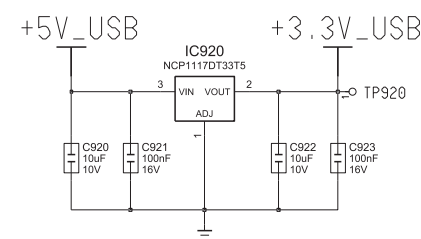
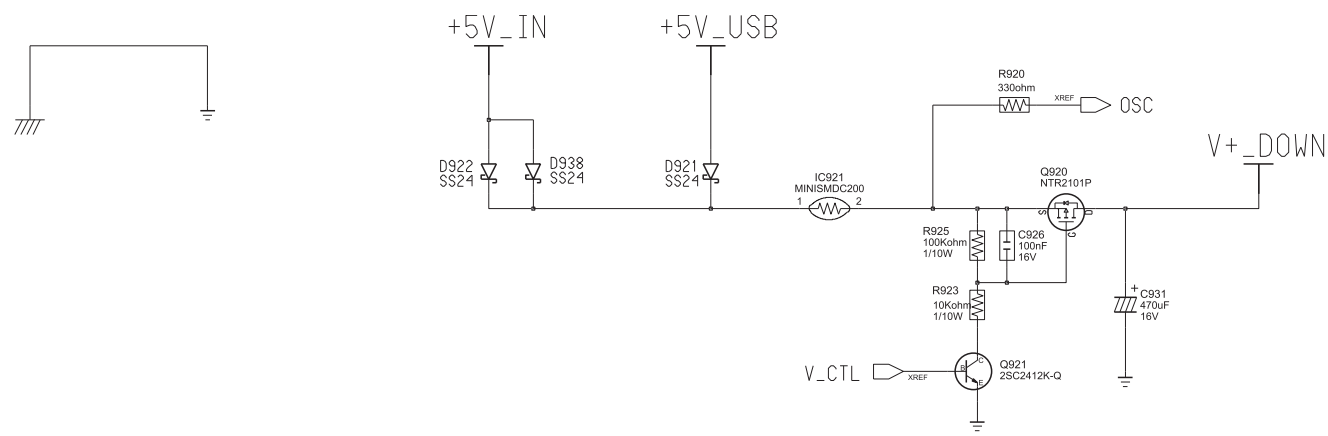

7-2-5 Power Block

This Document can not be used without Samsung's authorization.

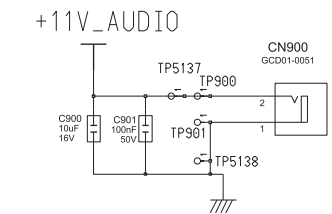
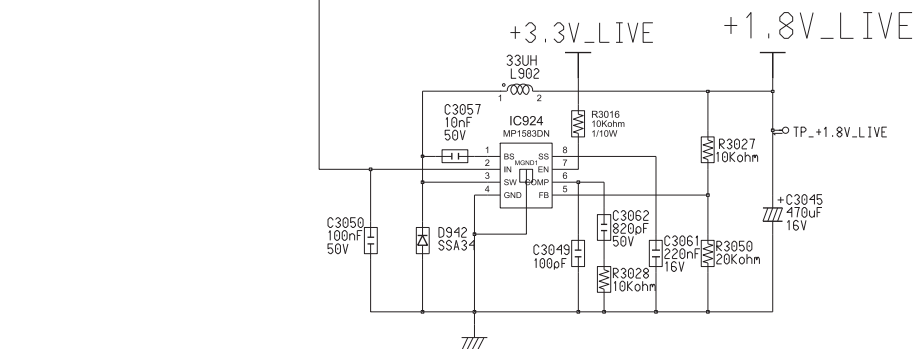
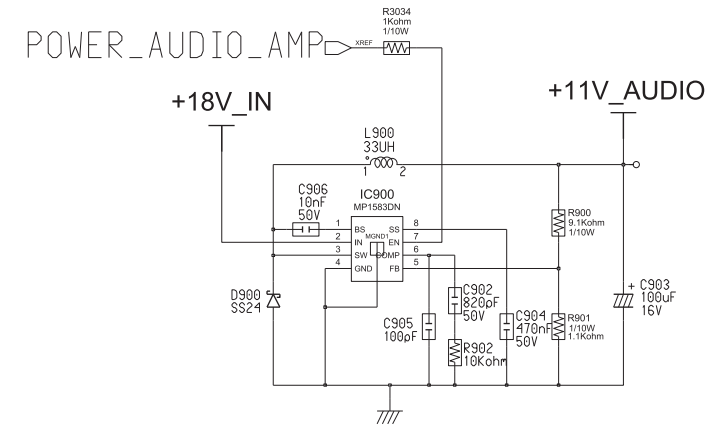
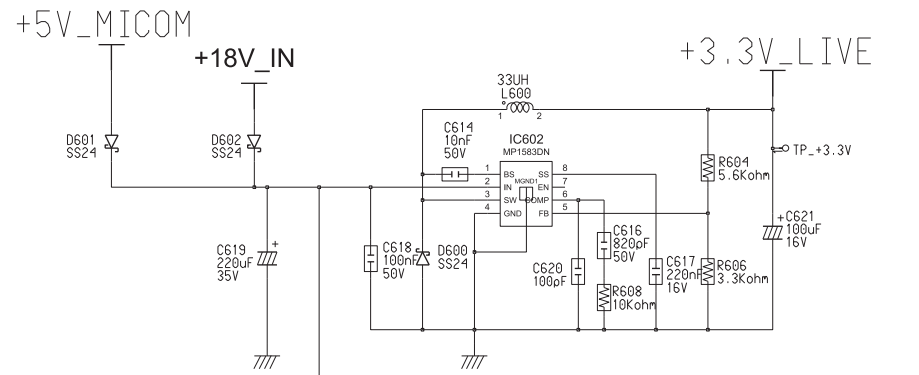
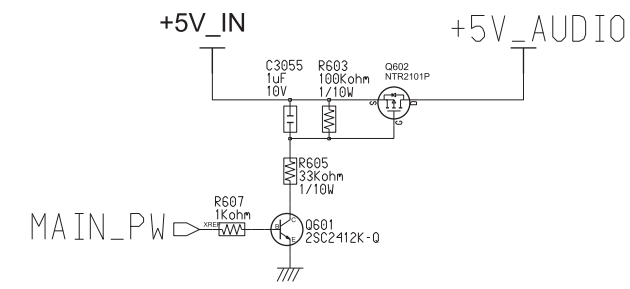
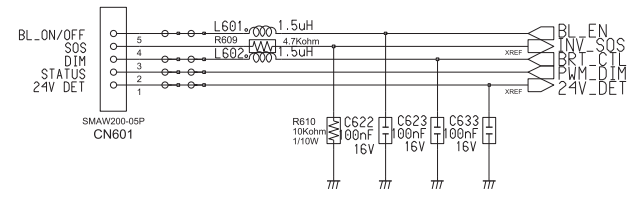
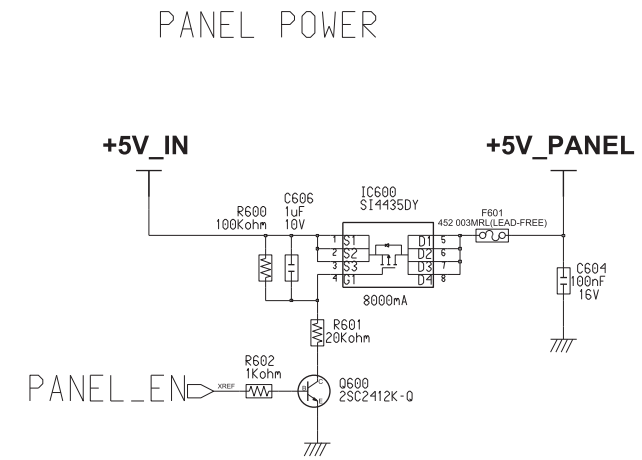
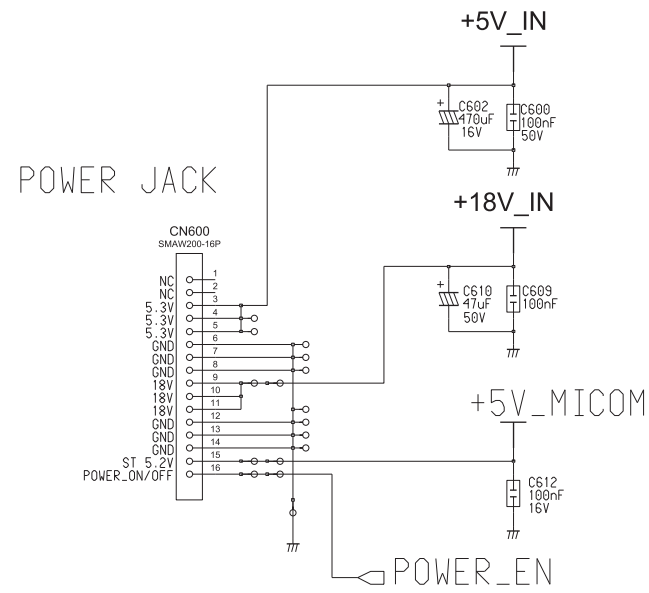

Memo