

# 7. Schematic Diagram

## 7-1. Circuit Descriptions

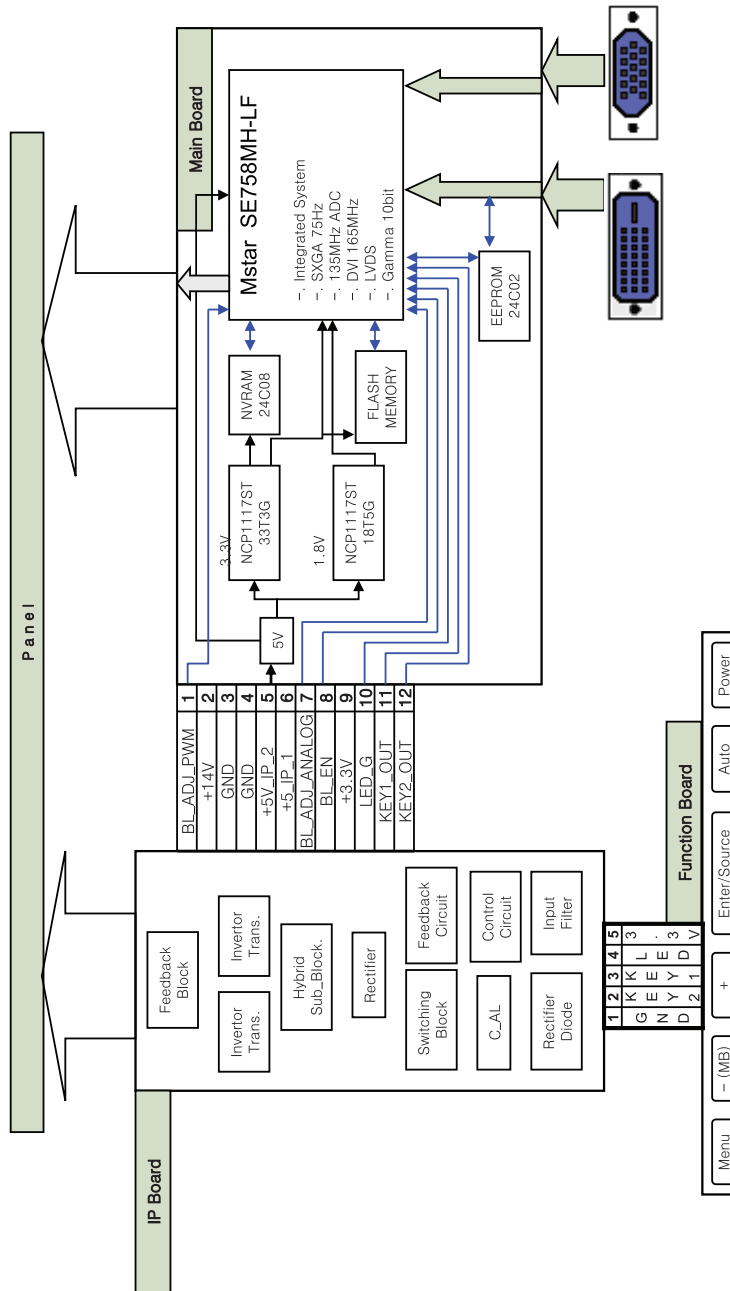

Location	Function	Remark
Scaler IC200	Besides the ADC, LVDS, and scaling part, an MCU is embedded as well. All of them are integrated into one chip.	SE758MH-LF
Flash Memory IC201	Stores the MCU program embedded in the scaler. It is of a flash type and rewritable.	MX25L1005MC
IC203	Stores the OSD and various timing values.	24C08
IC202	The memory to which DIGITAL DDC data is input	24C02
Regulator	An IC that receives DC voltage inputs. It is used in circuits that stabilize the DC voltage.	NCP117DT18T5G NCP117ST33T3G

### 7-2. Schematic Diagrams (Scaler Part)

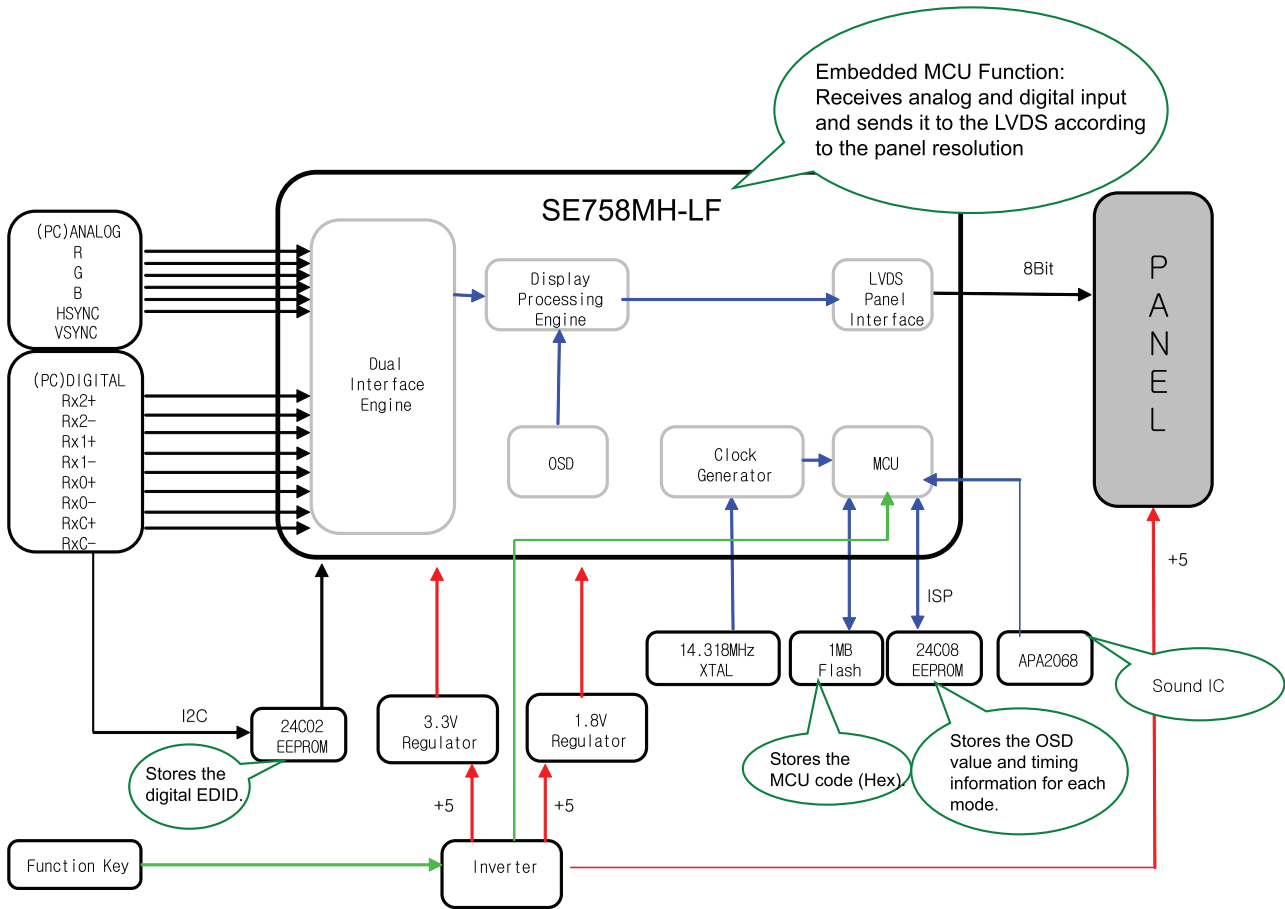

### 7-3. Schematic Diagrams (Power Flowchart)

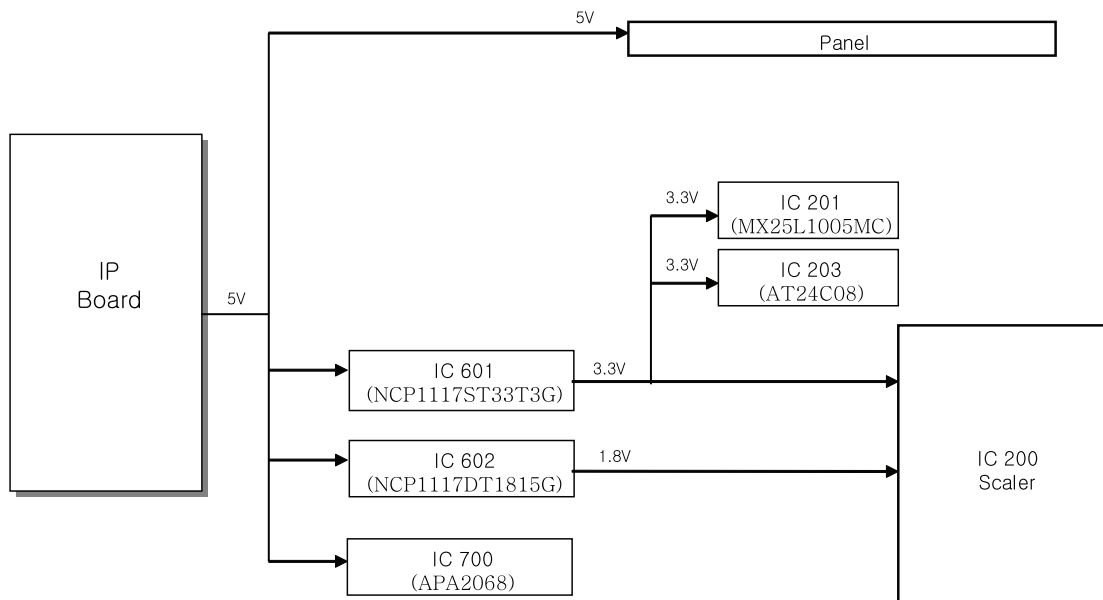

### 7-4. Schematic Diagrams (IP Board)

■ SMPS Part

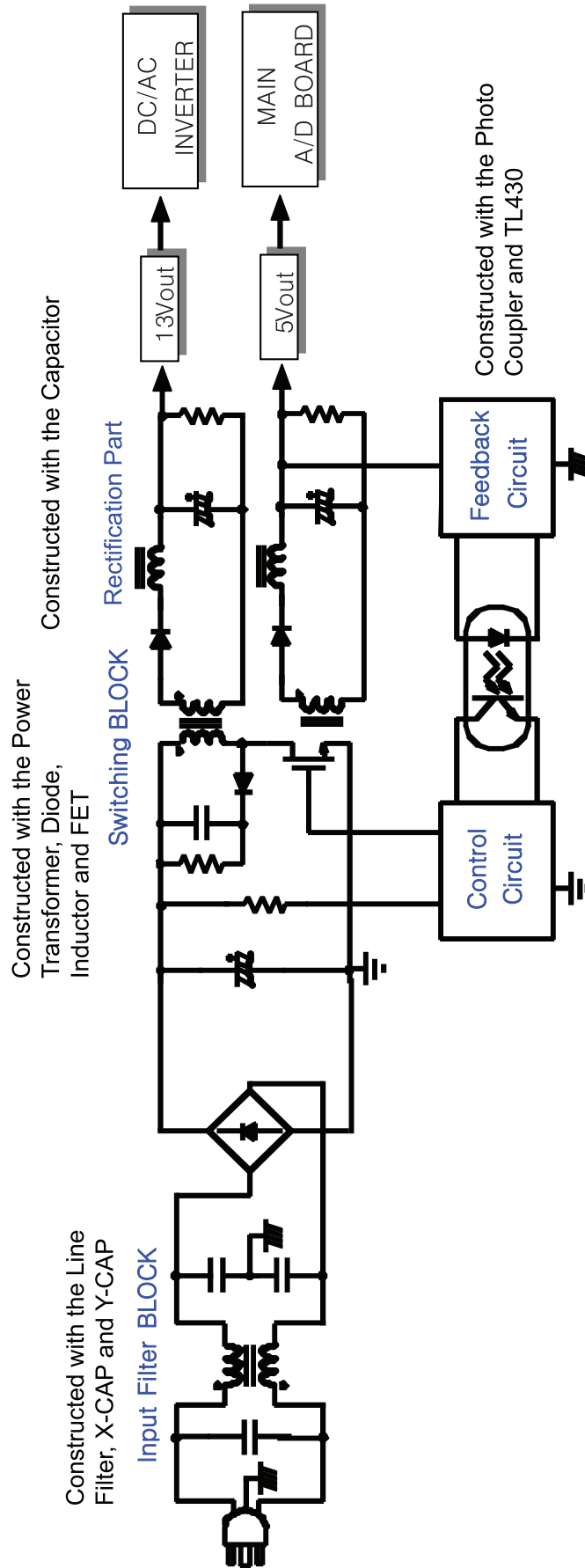

■ Inverter Part

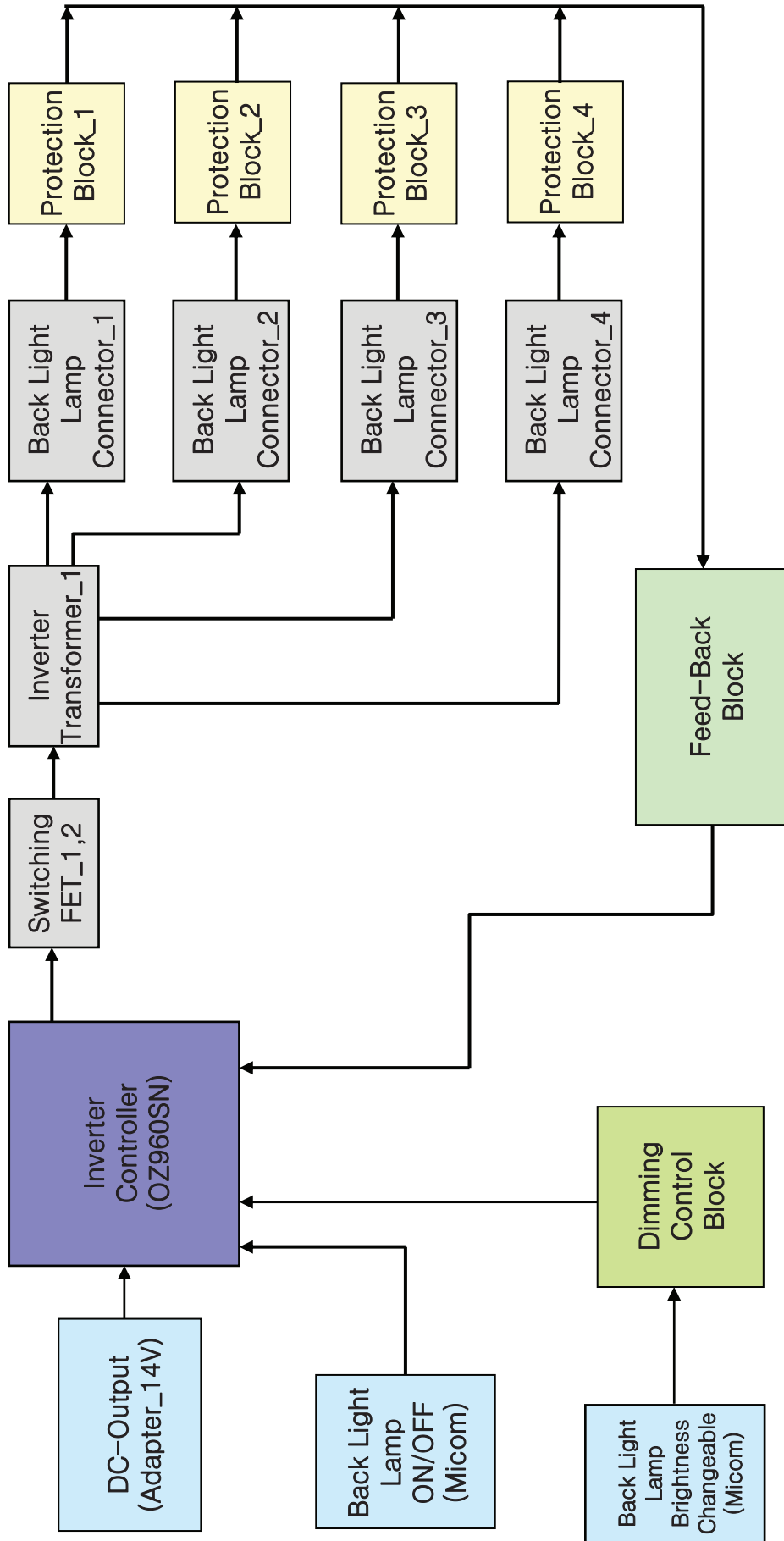

### 7-5. Schematic Diagrams (Main PBA)

This Document can not be used without Samsungs authorization.

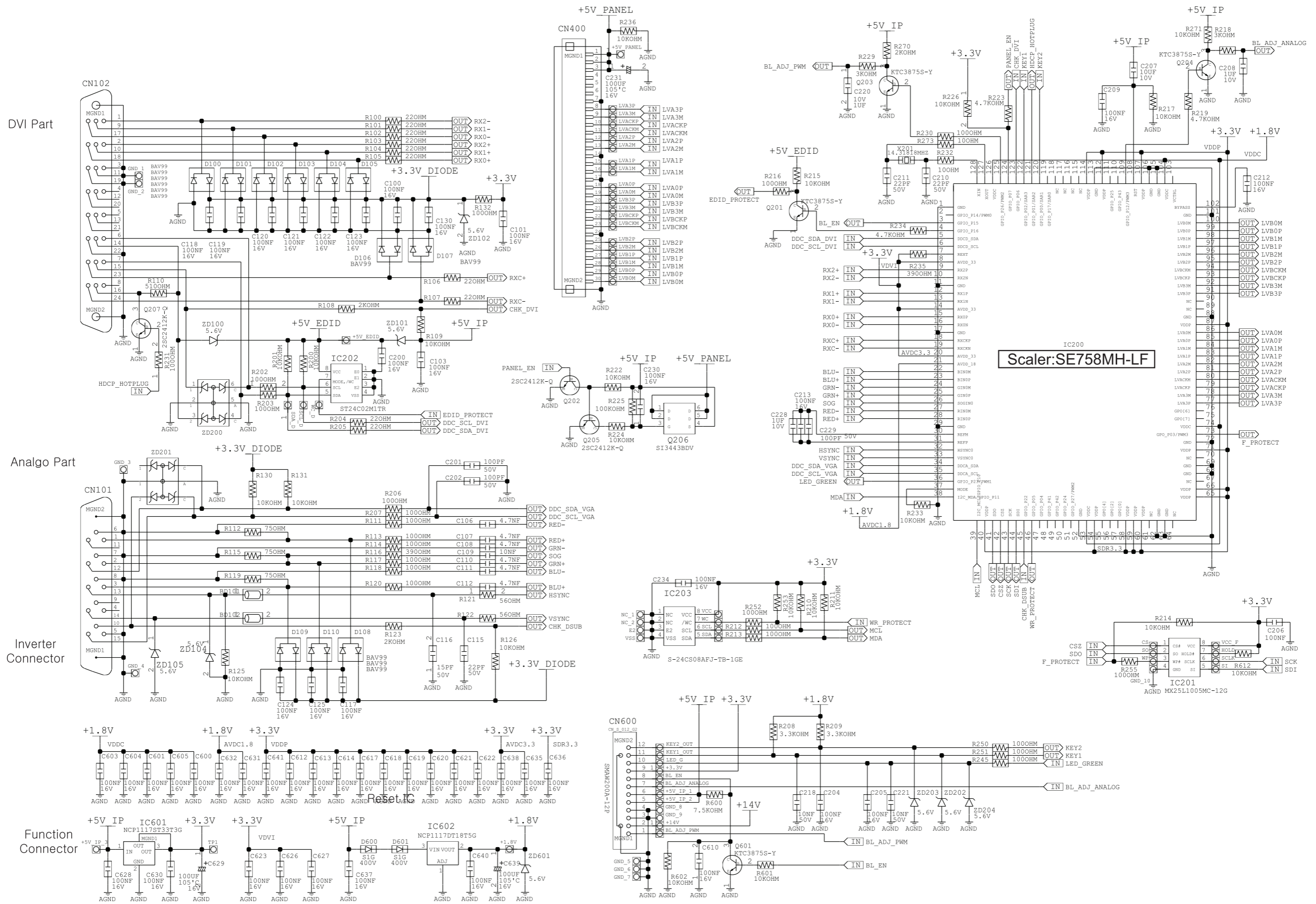

## Memo