

Service
Service
Service



200WB7EB/27
200WB7ES/00
200WB7ES/69
200WB7ES/75
200WB7ES/93
200WB7ES/96
200XW7EB/00



Service Manual

Horizontal frequencies
30 - 98 kHz

TABLE OF CONTENTS

Description	Page	Description	Page
Important Safety Notice-----	2	Wiring Diagram-----	29
Technical Data-----	3	Block Diagram-----	30
Instalation/On Screen Display-----	4~7	Scaler Diagram&C.B.A. -----	31~38
Lock/unlock, Aging, Factory mode-----	8	Control Diagram&C.B.A. -----	39~40
Philips Pixel Defect Policy-----	9	USB Diagram&C.B.A.-----	41~42
Mechanical Instructions -----	10~11	Power Diagram & C.B.A. -----	43~46
Color adjustment -----	12	Exploded View -----	47
Safety Test Requirments-----	13	General product specification-----	48~59
Troubleshooting -----	14	Spare&Recommended parts list-----	60~62
Electrical instruction -----	15~16	Repair tips-----	63~64
DDC Instructions&Serial Number -----	17~23	Repair Flow chart-----	65~67
DDC DATA -----	24~26	Different parts list-----	68~71
ISP Instructions -----	27~28	Revision List-----	72

SAFETY NOTICE

ANY PERSON ATTEMPTING TO SERVICE THIS CHASSIS MUST FAMILIARIZE HIMSELF WITH THE CHASSIS AND BE AWARE OF THE NECESSARY SAFETY PRECAUTIONS TO BE USED WHEN SERVICING ELECTRONIC EQUIPMENT CONTAINING HIGH VOLTAGES.

CAUTION: USE A SEPARATE ISOLATION TRANSFORMER FOR THIS UNIT WHEN SERVICING.

REFER TO BACK COVER FOR IMPORTANT SAFETY GUIDELINES

Important Safety Notice

Proper service and repair is important to the safe, reliable operation of all HP Consumer Electronics Company** Equipment. The service procedures recommended by HP and described in this service manual are effective methods of performing service operations. Some of these service operations require the use of tools specially designed for the purpose. The special tools should be used when and as recommended.

It is important to note that this manual contains various CAUTIONS and NOTICES which should be carefully read in order to minimize the risk of personal injury to service personnel. The possibility exists that improper service methods may damage the equipment. It is also important to understand that these CAUTIONS and NOTICES ARE NOT EXHAUSTIVE. HP could not possibly know, evaluate and advise the service trade of all conceivable ways in which service might be done or of the possible hazardous consequences of each way. Consequently, HP has not undertaken any such broad evaluation. Accordingly, a servicer who uses a service procedure or tool which is not recommended by HP must first satisfy himself thoroughly that neither his safety nor the safe operation of the equipment will be jeopardized by the service method selected.

** Hereafter throughout this manual, HP Consumer Electronics Company will be referred to as HP.

WARNING

Critical components having special safety characteristics are identified with a by the Ref. No. in the parts list and enclosed within a broken line*

(where several critical components are grouped in one area) along with the safety symbol on the schematics or exploded views.

Use of substitute replacement parts which do not have the same specified safety characteristics may create shock, fire, or other hazards.

Under no circumstances should the original design be modified or altered without written permission from Philips. Philips assumes no liability, express or implied, arising out of any unauthorized modification of design.

Servicer assumes all liability.

* Broken Line



FOR PRODUCTS CONTAINING LASER :

- DANGER- Invisible laser radiation when open.
AVOID DIRECT EXPOSURE TO BEAM.
- CAUTION- Use of controls or adjustments or performance of procedures other than those specified herein may result in hazardous radiation exposure.
- CAUTION- The use of optical instruments with this product will increase eye hazard.

TO ENSURE THE CONTINUED RELIABILITY OF THIS PRODUCT, USE ONLY ORIGINAL MANUFACTURER'S REPLACEMENT PARTS, WHICH ARE LISTED WITH THEIR PART NUMBERS IN THE PARTS LIST SECTION OF THIS SERVICE MANUAL.

Take care during handling the LCD module with backlight unit

- Must mount the module using mounting holes arranged in four corners.
- Do not press on the panel, edge of the frame strongly or electric shock as this will result in damage to the screen.
- Do not scratch or press on the panel with any sharp objects, such as pencil or pen as this may result in damage to the panel.
- Protect the module from the ESD as it may damage the electronic circuit (C-MOS).
- Make certain that treatment person's body are grounded through wrist band.
- Do not leave the module in high temperature and in areas of high humidity for a long time.
- Avoid contact with water as it may cause a short circuit within the module.
- If the surface of the panel becomes dirty, please wipe it off with a soft material. (Cleaning with a dirty or rough cloth may damage the panel.)

LCD panel

Type NR.	: QD20AL01 (QDI)
Outside dimensions	: 459.4(H)*296.4(V)*23.7(D) (Typ) mm
Pixel Pitch (mm)	: 0.258 mm x 0258mm
Color pixel arrangement	: RGB vertical stripes
Display surface	: low reflection, antiglare with hard coating
Color depth	: 16.2M colors (6 bits)
Backlight	: Six CCFL 's
Active area(WxH)	: 433.44x270.9mm (20.1 ''W diagonal)
View angle	: Horizontal 140& Vertical 125 degree (CR>=10)
Contrast ratio	: 600:1 (Typ) ,400 :1 (min)
White luminance	: Panel original color >240nits (min), 300 nits (Typ.)
Main voltage	: AC 90 - 135 Vrms and 170 - 264 Vrms, 50/60±2 Hz
Power cord length	: 1.8M
Power cord type	: 3 lead with earth plug
Power indicator	: LED (ON: green, Standby: amber, NEW MODE: flashing Green twice per second before user adjust and save it.).
Auto power saving	: EPA, Nutek, VESA DPMS
Horizontal scan	: 30 - 98 KHz
Vertical scan	: 56 - 76 Hz
Horizontal scanning	
Sync polarity	: Positive or negative
Scanning frequency	: 30 - 98 K Hz
Vertical scanning	
Sync polarity	: Positive or negative
Scanning frequency	: 56 - 76 Hz
Mechanical	
Pedestal	: Detachable
Tilt angle	: -5° to 35°
Swivel rotation	: ±175°

Input DVI-D connector pin

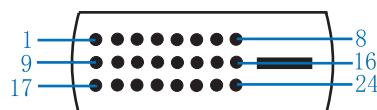

Pin No.	Description
1	T.M.D.S. data2-
2	T.M.D.S. data2+
3	T.M.D.S. data2 shield
4	No Connect
5	No Connect
6	DDC clock
7	DDC data
8	No Connect
9	T.M.D.S. data1-
10	T.M.D.S. data1+
11	T.M.D.S. data1 shield
12	No Connect
13	No Connect
14	+5V Power
15	Ground (for +5V) - Cable detect
16	Hot plug detect
17	T.M.D.S. data0-
18	T.M.D.S. data0+
19	T.M.D.S. data0 shield
20	No Connect
21	No Connect
22	T.M.D.S clock shield
23	T.M.D.S. clock+
24	T.M.D.S. clock-

Automatic Power Saving

If you have VESA DPMS compliance display card or software installed in your PC, the monitor can automatically reduce its power consumption when not in use. If an input from a keyboard, mouse or other input device is detected, the monitor will be waken up automatically by your PC. The following table shows the power consumption and signaling of this automatic power saving feature:

Power Management Definition					
VESA Mode	Video	H-sync	V-sync	Power Used	LED color
Active	ON	Yes	Yes	< 48W	Green
Sleep	OFF	No	No	< 2W	Amber
Switch	OFF	-	-	< 1W	OFF

Environmental conditions

Operating	
-Temperature C	: 0°c to 35°c
-Humidity	: 80 % max
-Altitude	: 0-3658m
-Air pressure	: 600-1100mBAR

Storage	
-Temperature C	: -30 to 60°
-Humidity	: 85% max (< 40°c)
-Altitude	: 0-12192m
-Air pressure	: 300-1100mBAR

Note: recommend at 5°c to 35°c, Humidity less than 60 %

Pin Assignment

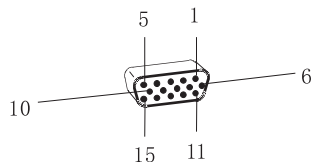



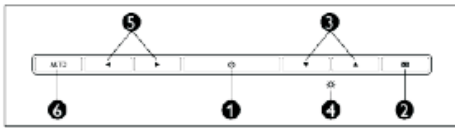

Pin No.	Assignment	Pin No.	Assignment
1	Red video input	9	DDC +3.3V OR +5V
2	Green video input	10	GND
3	Blue video input	11	GND
4	GND	12	Serial data line (SDA)
5	Cable detect	13	H-sync
6	Red video GND	14	V-sync
7	Green video GND	15	Data clock line (SCL)
8	Blue video GND		

Installation

Front View





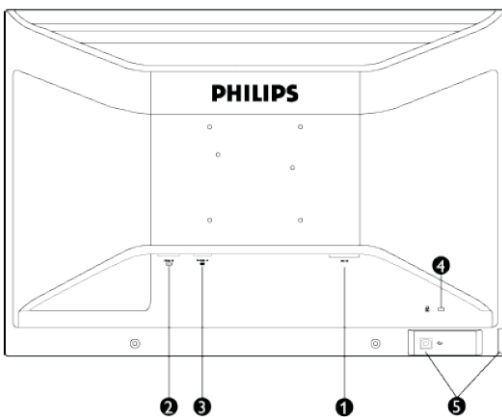

- | | | |
|---|---|--|
| 1 |  | To switch monitor's power On and Off |
| 2 |  | To access OSD menu |
| 3 |  | To adjust the OSD |
| 4 |  | To adjust brightness of the display |
| 5 |  | To adjust the OSD |
| 6 | AUTO | Automatically adjust the horizontal position, vertical position, phase and clock setting |

Rear View



- | | |
|---|----------------------------|
| 1 | AC power input |
| 2 | DVI-I input |
| 3 | VGA input |
| 4 | Kensington anti-theft lock |
| 5 | USB upstream |

Accessory Pack

Item	Description
	Power cord
	VGA signal cable
	DVI-D cable
	USB cable
	EDFU pack

Connecting to Your PC

Connect the power cord and DVI cable to the back of the monitor firmly. (Philips has pre-connected VGA cable for the first installation.)

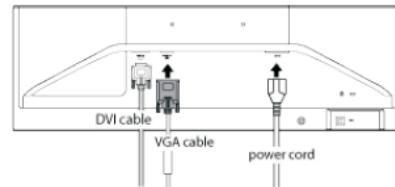

Notes: If you use an Apple Macintosh™, you need to connect the special Mac adapter to one end of the monitor signal cable.

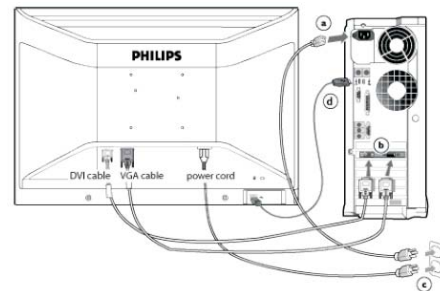

Connect the cables to the back of your computer by following these steps:

- Turn off your computer and unplug its power cord.
- Connect the monitor signal cable to the video connector on the back of your computer.
- Plug the power cord on your computer and your monitor into a nearby outlet.
- USB plug
 - Connect USB upstream port on monitor and the USB port on PC with a USB cable.
 - The USB downstream port is now ready for any USB device to plug in.
- Turn on your computer and monitor. If the monitor displays an image, installation is complete.

Note: The USB plug is a pass through connection whether it can support USB 1.1 or USB 2.0 depends on your PC's specification.

Rotating the Monitor

Before rotating the monitor, remove the lock on the back of the base and raise the monitor to a higher vertical height adjustment to avoid hitting the bottom edge of the monitor when rotating.

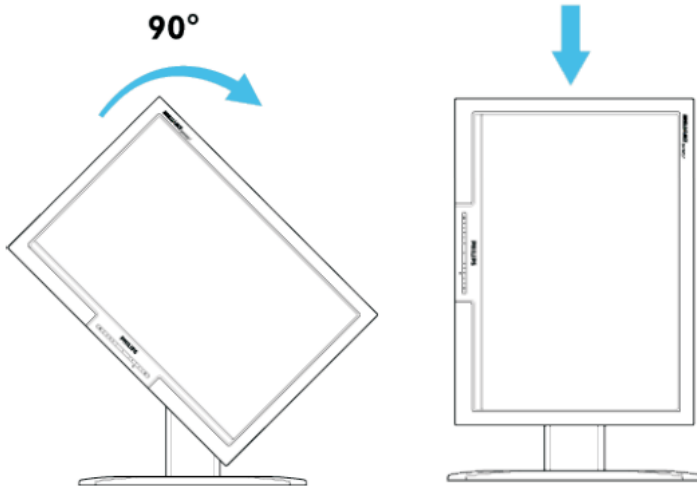
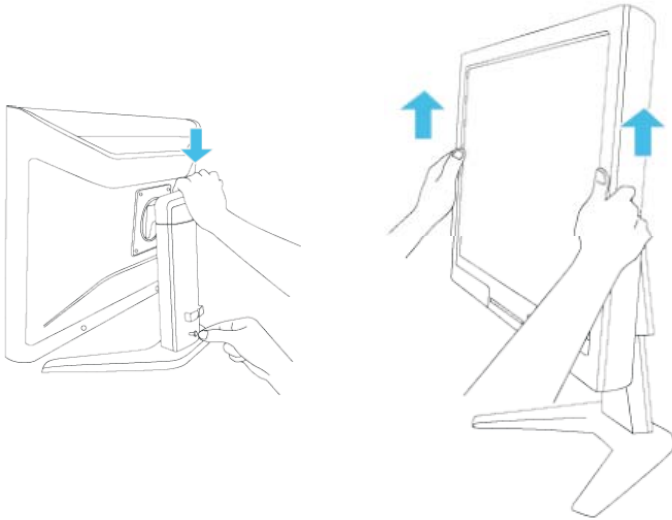

The Base

1) Place the monitor face down on a smooth surface taking care to avoid scratching or damaging the screen.

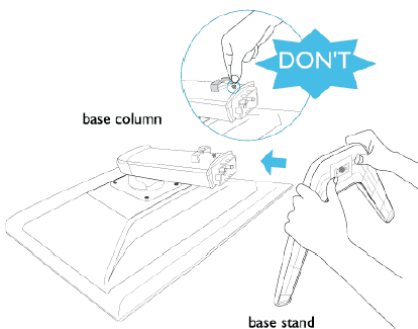

Do not release the pin before the base stand is firmly fixed to the base column.

2) Hold the monitor base with both hands and firmly fix the base plate into four-pronged base attachments.

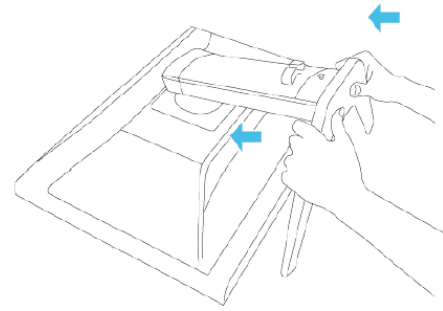

3) Fastening base stand with the monitor.

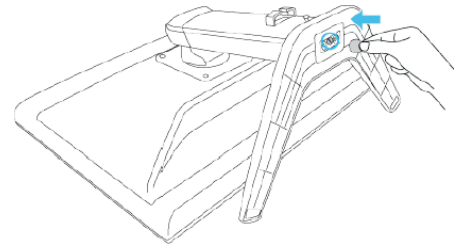

VESA Standard Mounting

1) Place monitor face down on a smooth surface.

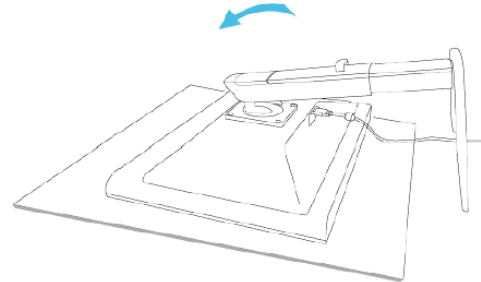

2) Unscrew the 4 screws at the base.

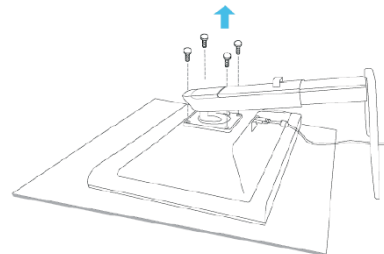

3) VESA mounting holes

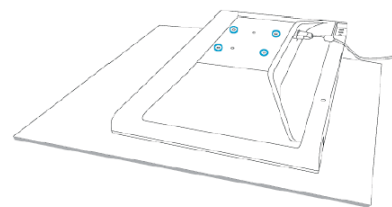

4) Install the wall mount

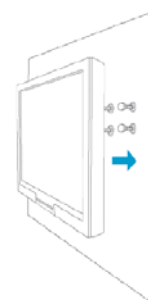



On Screen Display

Description of the On Screen Display

This is a feature in all Philips LCD monitors. It allows an end user to adjust screen performance of the monitors directly through an on-screen instruction window. The user interface provides userfriendliness and ease-of-use when operating the monitor.

Basic and simple instruction on the control keys.

When you press  the button on the front control of your monitor, the On-Screen Display (OSD) Main Controls window will pop up and you can then start making adjustments to your monitor's various features. Use the  or the  keys to make your adjustments.



The OSD Tree

Below is an overall view of the structure of the On-Screen Display. You can use this as a reference when you want to work your way around the different adjustments later on.

Only available for Europe Model

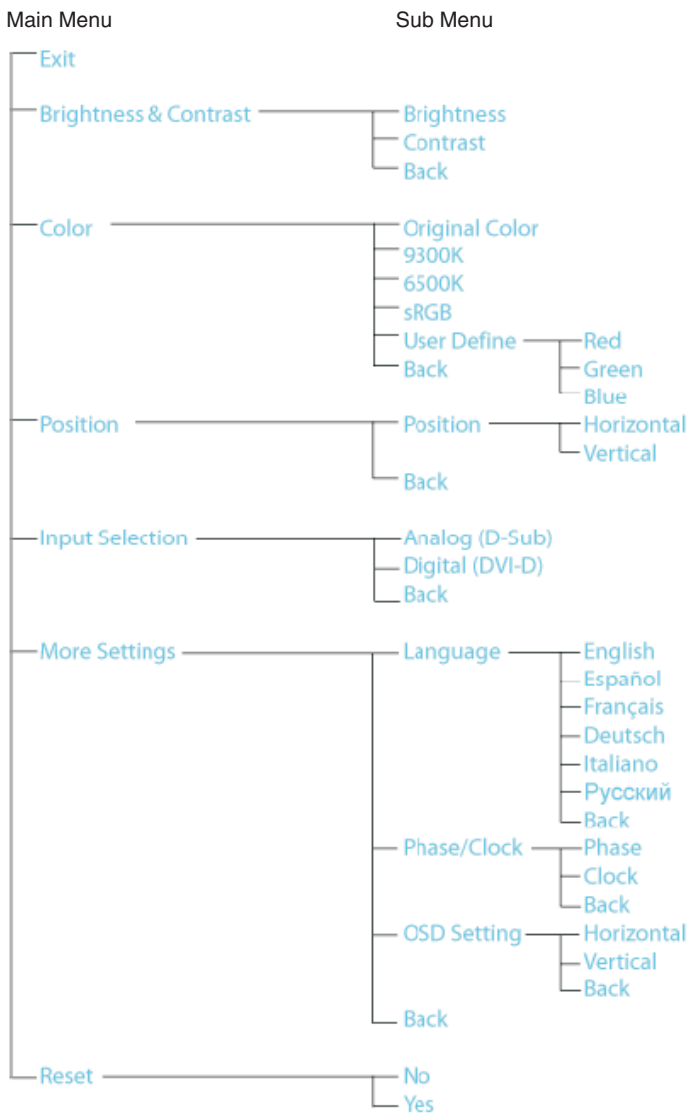

Only available for Nafta Model

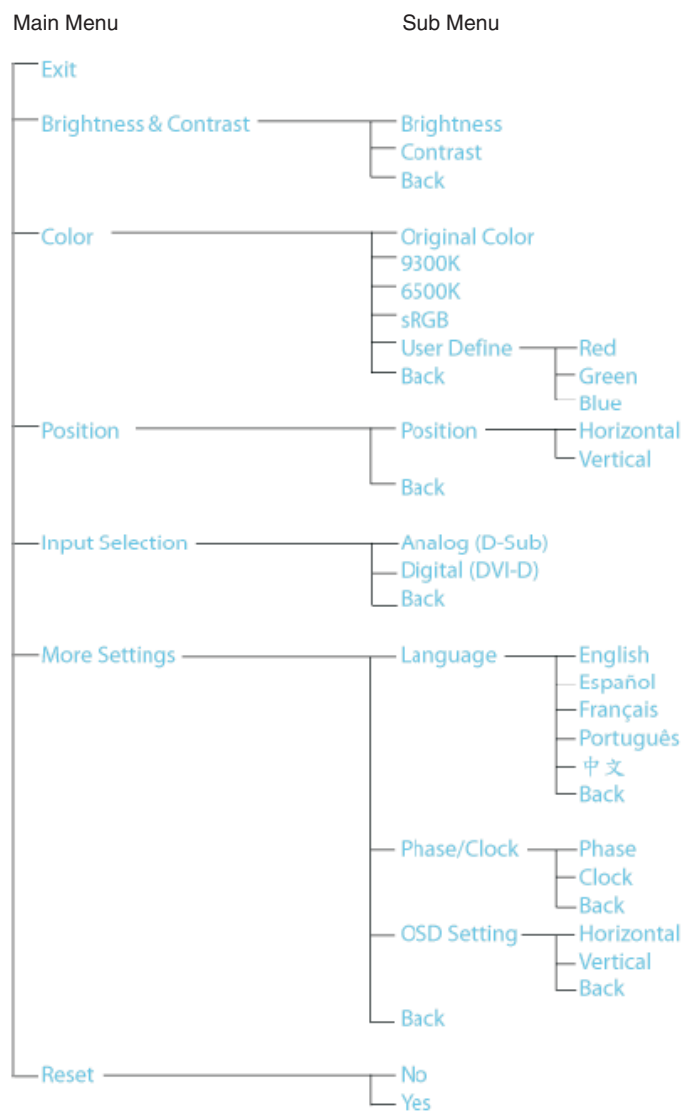

Only available for Asia Pacific Model

Main Menu

Sub Menu

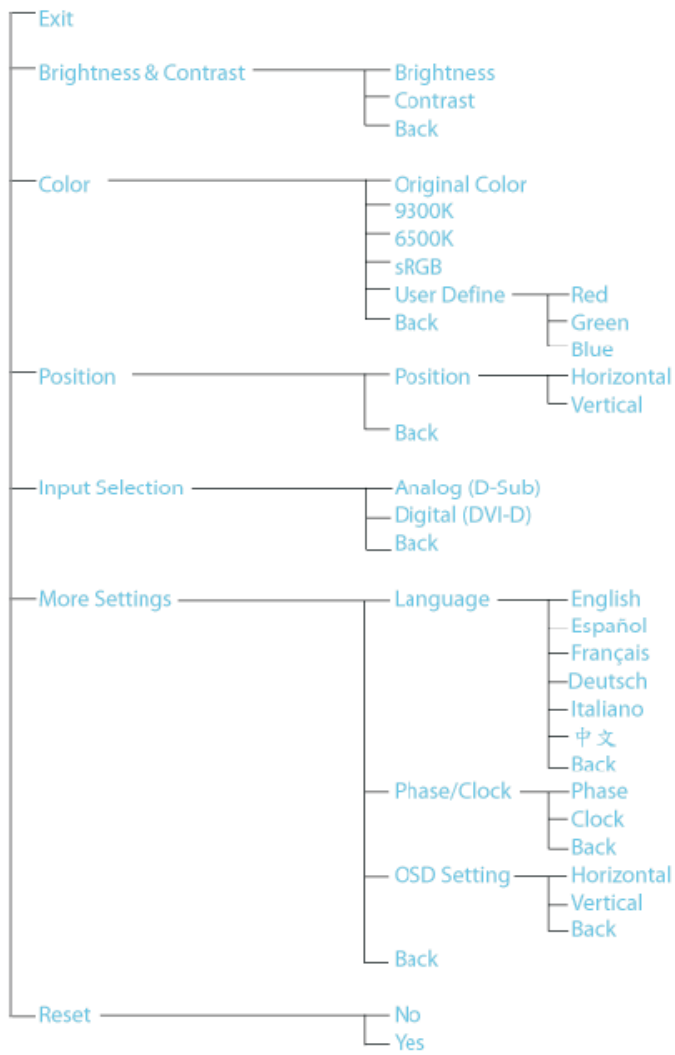

Lock/Unlock, Aging, Factory Mode

Front Control

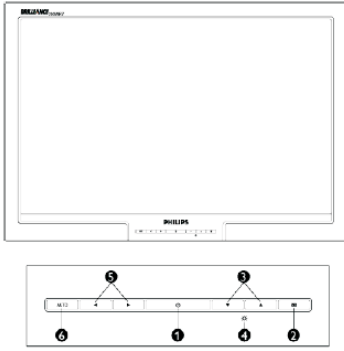

To Lock/Unlock OSD FUNCTION(User Mode)

The OSD function can be locked by pressing "OK" button(1) for more than 10 seconds, the screen shows following windows for 4 seconds. Everytime when you press "OK" button, this message appears on the screen automatically.



Unlock OSD function

Unlocked OSD function can be released by pressing "OK" button for more than 10 seconds again.

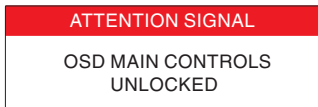

Access Aging Mode

Step 1 : Disconnect Interface Cable between Monitor and PC.
Step 2 : Turn off LCD monitor. Then [Push "AUTO" & "OK" buttons at the same time and hold them]+[Press power "P" button until comes out " AGING screen"] => then release all buttons.
Bring up:



After 15 seconds, bring up:

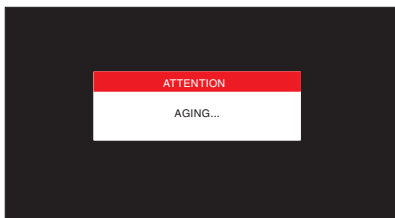

After 15 seconds, bring up:

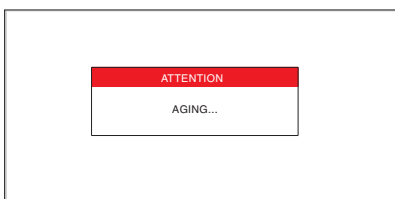

After 15 seconds, bring up:



repealty

Connect Signal cable again=> go back to normal display

Access Factory Mode

- 1). Turn off monitor.
- 2). [Push "AUTO" & "OK" buttons at the same time and hold them] +[Press "power" button until comes out "Windows screen"] => then release all buttons
- 3). Press "OK" button, wait until the OSD menu with Characters "HUDSON 200WB7 V011 2006/02/16" (below OSD menu) come on the Screen of the monitor.

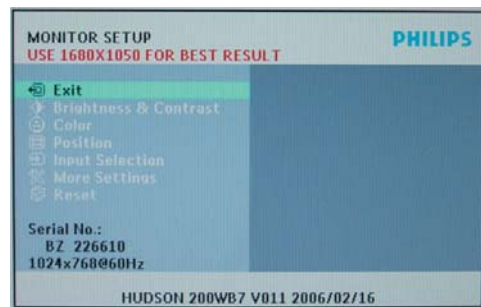

↑
Factory Mode indicator

Factory Menu

Cursor can move on gray color area

Hot key function: by pressing " UP " and " DOWN " key Simultaneously at User Mode (or Factory Mode)

(PS: The Offset R G B function can be used on reduce or eliminate snowy noise on the background when the resolution of video signal is 1280*1024 vertical 60Hz. Slightly increase or decrease the value until snowy noise completely disappear.

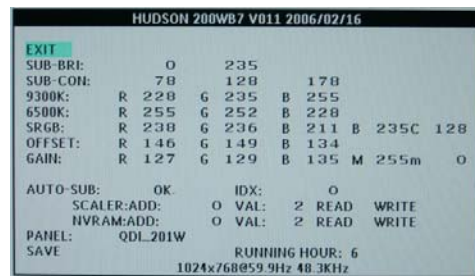

Philips' Flat Panel Monitors Pixel Defect Policy

Philips strives to deliver the highest quality products. We use some of the industry's most advanced manufacturing processes and practice stringent quality control. However, pixel or sub pixel defects on the TFT LCD panels used in flat panel monitors are sometimes unavoidable. No manufacturer can guarantee that all panels will be free from pixel defects, but Philips guarantees that any monitor with an unacceptable number of defects will be repaired or replaced under warranty. This notice explains the different types of pixel defects and defines acceptable defect levels for each type. In order to qualify for repair or replacement under warranty, the number of pixel defects on a TFT LCD panel must exceed these acceptable levels. For example, no more than 0.0004% of the sub pixels on a 15" XGA monitor may be defective. Furthermore, Philips sets even higher quality standards for certain types or combinations of pixel defects that are more noticeable than others. This policy is valid worldwide.

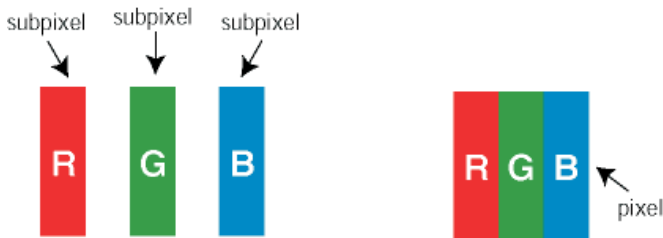

Pixels and Sub pixels

A pixel, or picture element, is composed of three sub pixels in the primary colors of red, green and blue. Many pixels together form an image. When all sub pixels of a pixel are lit, the three colored sub pixels together appear as a single white pixel. When all are dark, the three colored sub pixels together appear as a single black pixel. Other combinations of lit and dark sub pixels appear as single pixels of other colors.

Types of Pixel Defects

Pixel and sub pixel defects appear on the screen in different ways. There are two categories of pixel defects and several types of sub pixel defects within each category. Bright dot defects appear as pixels or sub pixels that are always lit or 'on'. These are the types of bright dot defects:



One lit red, green or blue sub pixel

Two adjacent lit sub pixels:
 - Red + Blue = Purple
 - Red + Green = Yellow
 - Green + Blue = Cyan (Light Blue)

Three adjacent lit sub pixels (one white pixel)

Black Dot Defects Black dot defects appear as pixels or sub pixels that are always dark or 'off'. These are the types of black dot defects:

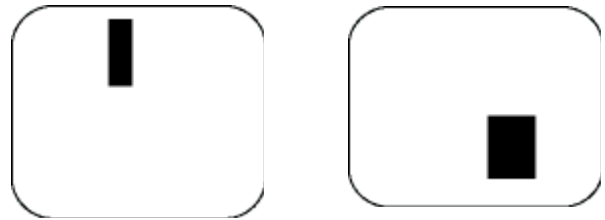

One dark sub pixel

Two or three adjacent dark sub pixels

Proximity of Pixel Defects

Because pixel and sub pixels defects of the same type that are near to one another may be more noticeable, Philips also specifies tolerances for the proximity of pixel defects.

Pixel Defect Tolerances

In order to qualify for repair or replacement due to pixel defects during the warranty period, a TFT LCD panel in a Philips flat panel monitor must have pixel or sub pixel defects exceeding the tolerances listed in the following tables.

BRIGHT DOT DEFECTS	ACCEPTABLE LEVEL
MODEL	200WB7
1 lit subpixel	3 or fewer
2 adjacent lit subpixels	1 or fewer
3 adjacent lit subpixels (one white pixel)	0
Distance between two bright dot defects*	25mm or more
Total bright dot defects of all types	3 or fewer

BLACK DOT DEFECTS	ACCEPTABLE LEVEL
MODEL	200WB7
1 dark subpixel	5 or fewer
2 adjacent dark subpixels	2 or fewer
3 adjacent dark subpixels	1 or fewer
Distance between two black dot defects*	15 mm or more
Total black dot defects of all types	5 or fewer

TOTAL DOT DEFECTS	ACCEPTABLE LEVEL
MODEL	200WB7
Total bright or black dot defects of all types	5 or fewer

Note:

* 1 or 2 adjacent sub pixel defects = 1 dot defect

All Philips monitors are ISO13406-2 Compliant

Mechanical Instruction

Front view



Fig.1

Step 4: Pull out the foot from base as Fig.6, Fig.7.

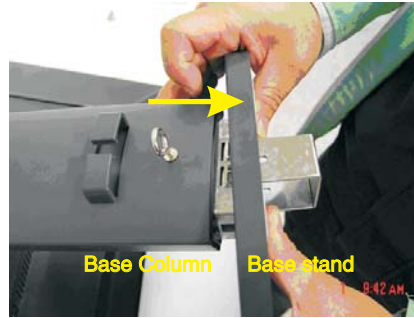

Fig.6

Back view



Fig.2



Fig.7

2. Remove the Base column as Fig.8.
Unscrew the 4 screws

1. Remove the base.

Step 1: Place the monitor face down on a smooth surface as Fig 3.
Be carefully to prevent the scratch and injury during the uninstallation.



Fig.3



Fig.8

Step 2: Unfasten one screw on the base stand as Fig 4.



Fig.4

3: Remove the Back Cover Assy

- a. Unscrew 2 screws as shown in Fig.9.
- b. Open 4 clicks on right and left side as shown in Fig.10 and Fig.11.
- c. Open 3 clicks on bottom side as shown in Fig.12.
- d. Open 5 clicks on top side as shown in Fig.13.
- e. Remove the BACK COVER ASSY in Fig.14.



Fig.9

Step 3: Firmly insert the base removal tool into four-pronged clicks as Fig 5.

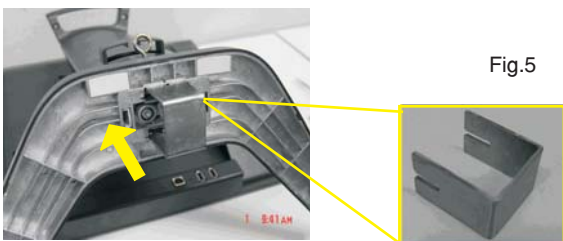

Fig.5



Fig.10



Fig.11



Fig.12

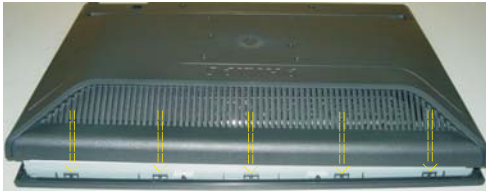

Fig.13

4. Remove the Scaler ,USB,Control and Power board.
 - a. Unscrew the 12 screws to remove the SHIELDING ASSY as Fig.14.
 - b. Unscrew the 4 screws and disconnect the 1 cables to remove the Control and USB board as Fig. 15.
 - c. Unscrew the 9 screws and disconnect the 7 cables to remove the Scaler ,Audio and Power board as Fig. 16.



Fig. 17

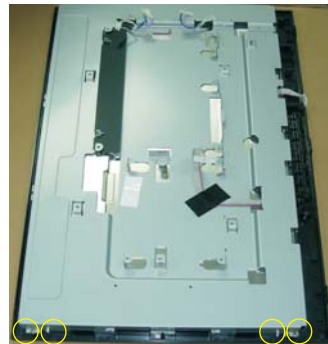

Fig. 18

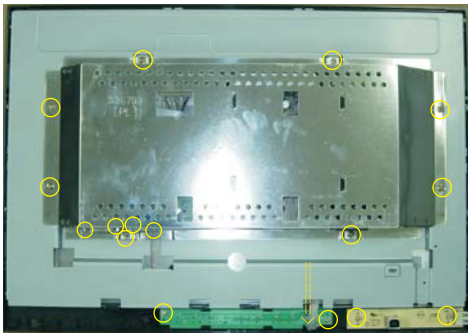

Fig.14



Fig.15



Fig. 16

LCD Panel

1050 823827719061 TFT-LCD MOD QD20AL01 REV.01(Fig.19).



Fig. 19

 In warranty, it is not allowed to disassembly the LCD panel, even the backlight unit defect.

Out of warranty, the replacment of backlight unit is a correct way when the defect is cused by backlight (CCFL,Lamp).

5. Remove the LCD panel.

- a. Unscrew the 8 screws on left and right side as Fig.17 and Fig.18.
- b. Remove the BEZEL and METAL FRAME ASSY as Fig. 19.

Alignment procedure

1. Turn on the LCD monitor.
2. Turn on the Timing/pattern generator. See Fig.1
3. Preset LCD color Analyzer CA-110
 - Remove the lens protective cover of probe CA-A30.
 - Set measuring/viewing selector to measuring position for reset analyzer.(zero calibration) as Fig.2
 - Turn on the color analyzer (CA-110)
 - Press 0-CAL button to starting reset analyzer.

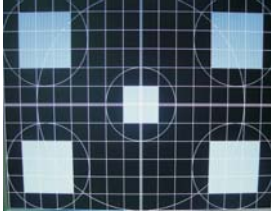

Fig. 1

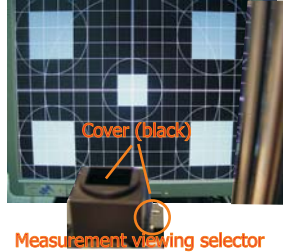
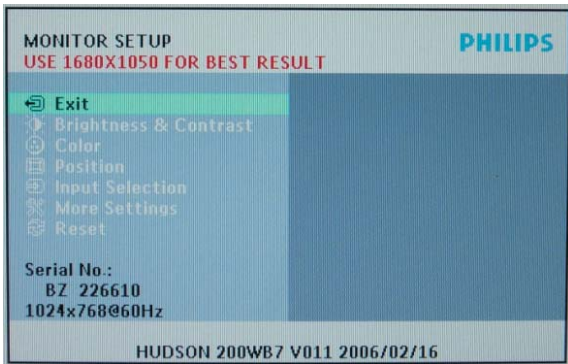

Fig. 2

4. Access Factory Mode

- 1). Turn off monitor.
- 2). [Push "AUTO" & "OK" buttons at the same time and hold them] +[Press "power" button until comes out "Windows screen"] => then release all buttons
- 3). Press "OK" button, wait until the OSD menu with Characters "HUDSON 200WB7 V011 2006/02/16" (below OSD menu) come on the Screen of the monitor. as shown in Fig3.



Factory Mode indicator

Fig. 3

- 4). Press "OK" button, then select factory mode indicator by "▼" button .Press"OK" button to bring up submenu windows as below:

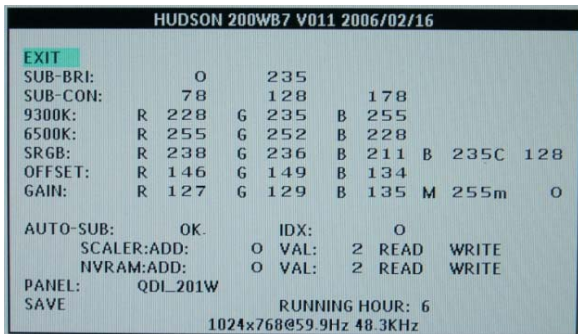

Fig. 4

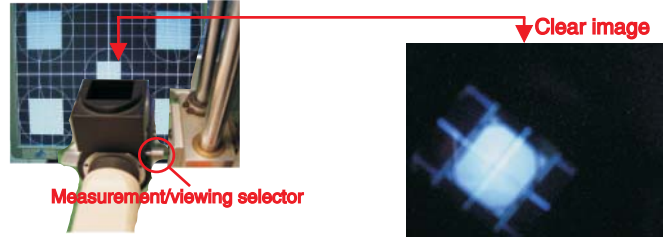

Fig.5

5. Display
 - Press "▲" or "▼" button to select . Change the value by "◀" or "▶" key until the X,Y co-ordinates as below

5.1 Auto color adjustment

Access to factory mode (IIC) in auto-alignment system The communication protocol switch to IIC .
Apply a 1280x1024/60Hz signal with Blackand white levels pattern, set brightness control at 100%, and contrast control at 50%.
Adjust the R. G. B offset, and gain to calibrate the color smoothly and 64-gray level distinguishable.
Check all factory pre-setting modes.

5.2 Adjustment of WHITE-D (B)

Apply a 1280*1024 / 60Hz signal with white pattern, set brightness control at 100%, and contrast control at 50%.
Adjust the R, G, B Sub-Gain, for the screen center, the 1931 CIE chromaticity (X, Y) co-ordinates shall be;

	9300°K	6500°K
x (center)	0.283 ± 0.005	0.313 ± 0.005
y (center)	0.297 ± 0.005	0.329 ± 0.005

Use Minolta CA-110 for colour coordinates and luminance check. Luminance is > 200 Nits in the center of the screen when brightness at 100% and contrast set to 100%.

5.3 Adjustment of sRGB

Apply a 1280*1024 / 60Hz signal with white pattern, set brightness control at 100%, and contrast control at 50%. Adjust the R, G, B Sub-Gain, for the screen center, the 1931 CIE chromaticity (X, Y) co-ordinates shall be;

	sRGB
x(center)	0.313 ± 0.008
y(center)	0.329 ± 0.008
Ynits	180 ± 10

5.4 Factory Preset (B):

After finished all the adjustment, set:
OSD Default Setting:
Brightness : 100%
Contrast : 50%
Adjust size: Full screen
Language : English
Colour : 6500K for IMAGE MANAGEMENT
OSD position : middle of the LCD screen
Input Selection : Default as PC VGA (D-sub)

5.5 In Factory mode default setting :

SECURITY : OFF
SUB-BRI : 0 235 (Fix)
SUB-CON : 78 128 178 (Fix)
PANEL: QDI

All units that are returned for service or repair must pass the original manufactures safety tests. Safety testing requires both *Hipot* and *Ground Continuity* testing.

HI-POT TEST INSTRUCTION

1. Application requirements

- 1.1 All mains operated products must pass the Hi-Pot test as described in this instruction.
- 1.2 This test must be performed again after the covers have been refitted following the repair, inspection or modification of the product.

2. Test method

2.1 Connecting conditions

- 2.1.1 The test specified must be applied between the parallel-blade plug of the mainscord and all accessible metal parts of the product.
- 2.1.2 Before carrying out the test, reliable conductive connections must be ensured and thereafter be maintained throughout the test period.
- 2.1.3 The mains switch(es) must be in the "ON" position.

2.2 Test Requirements

All products should be HiPot and Ground Continuity tested as follows:

Condition	HiPot Test for products where the mains input range is Full range(or 220V AC)	HiPot Test for products where the mains input is 110V AC(USA type)	Ground Continuity Test requirement
Test voltage	2820VDC (2000VAC)	1700VDC (1200VAC)	Test current: 25A,AC Test time: 3 seconds(min.) Resistance required: $\leq 0.09 + R_{ohm}$, R is the resistance of the mains cord.
Test time (min.)	3 seconds	1 second	
Trip current (Tester)	set at 100 uA for Max. limitation; set at 0.1 uA for Min. Limitation	5 mA	
Ramp time (Tester)	set at 2 seconds		

- 2.2.1 The minimum test duration for Quality Control Inspector must be 1 minute.
- 2.2.2 The test voltage must be maintained within the specified voltage + 5%.
- 2.2.3 There must be no breakdown during the test.
- 2.2.4 The grounding blade or pin of mains plug must be conducted with accessible metal parts.

3. Equipments and Connection

3.1. Equipments

For example :

- ChenHwa 9032 PROGRAMMABLE AUTO SAFETY TESTER
- ChenHwa 510B Digital Grounding Continuity Tester
- ChenHwa 901 (AC Hi-pot test), 902 (AC, DC Hi-pot test) Withstanding Tester

3.2. Connection

- * Turn on the power switch of monitor before Hipot and Ground Continuity testing.

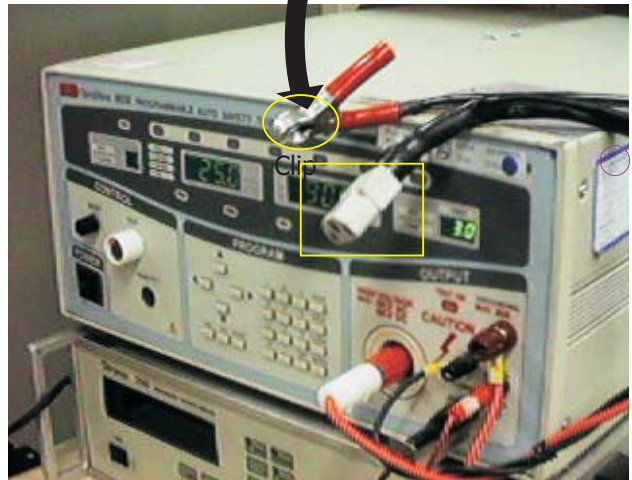

(ChenHwa 9032 tester)

Connect the "video cable" or "grounding screw" to the CLIP on your tester.



Connect the power cord to the monitor.





(Rear view of monitor)

4. Recording

Hipot and Ground Continuity testing records have to be kept for a period of 10 years.

Troubleshooting

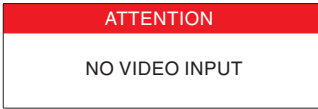
This page deals with problems that can be corrected by a user. If the problem still persists after you have tried these solutions, contact Philips customer service representative.

Common Problems	
Having this problem	Check these items
No Picture (Power LED not lit)	<ol style="list-style-type: none"> 1. Make sure the power cord is plugged into the power outlet and into the back of the monitor. 2. First, ensure that the power button on the front of the monitor is in the OFF position, then press it to the ON position.
No Picture (Power LED is amber or yellow)	<ol style="list-style-type: none"> 1. Make sure the computer is turned on. 2. Make sure the signal cable is properly connected to your computer. 3. Check to see if the monitor cable has bent pins. 4. The Energy Saving feature may be activated
Screen says 	<ol style="list-style-type: none"> 1. Make sure the monitor cable is properly connected to your computer. (Also refer to the Quick Set-Up Guide). 2. Check to see if the monitor cable has bent pins. 3. Make sure the computer is turned on.
AUTO button not working properly	<ol style="list-style-type: none"> 1. The Auto Function is designed for use on standard Macintosh or IBM-compatible PCs running Microsoft Windows. 2. It may not work properly if using nonstandard PC or video card.
Imaging Problems	
Display position is incorrect	<ol style="list-style-type: none"> 1. Press the Auto button. 2. Adjust the image position using the Horizontal Position and/or Vertical Position in OSD Main Controls.
Image vibrates on the screen	Check that the signal cable is properly connected to the graphics board or PC.
Vertical flicker appears 	<ol style="list-style-type: none"> 1. Press the Auto button. 2. Eliminate the vertical bars using the More Settings of Phase/Clock in OSD Main Controls.
Horizontal flicker appears 	<ol style="list-style-type: none"> 1. Press the Auto button. 2. Eliminate the vertical bars using the More Settings of Phase/Clock in OSD Main Controls.
The screen is too bright or too dark	Adjust the contrast and brightness on OSD Main Controls. (The backlight of the LCD monitor has a fixed life span. When the screen becomes dark or begins to flicker, please contact your dealer).
An after-image appears	If an image remains on the screen for an extended period of time, it may be imprinted in the screen and leave an afterimage. This usually disappears after a few hours.
An after-image remains after the power has been turned off.	This is characteristic of liquid crystal and is not caused by a malfunction or deterioration of the liquid crystal. The after-image will disappear after a period of time.
Green, red, blue, dark, and white dots Remains	The remaining dots are normal characteristic of the liquid crystal used in today's technology.

1. General points

- 1.1 During the test and measuring, supply a distortion free AC mains voltage to the apparatus via an isolated transformer with low internal resistance.
- 1.2 All measurements mentioned hereafter are carried out at a normal mains voltage (90 - 132 VAC for USA version, 195 - 264 VAC for EUROPEAN version, or 90 - 264 VAC for the model with full range power supply, unless otherwise stated.)
- 1.3 All voltages are to be measured or applied with respect to ground, unless otherwise stated.
Note: don't use heat-sink as ground.
- 1.4 The test has to be done on a complete set including LCD panel in a room with temperature of 25 +/- 5 degree C.
- 1.5 All values mentioned in these test instruction are only applicable of a well aligned apparatus, with correct signal.
- 1.6 The letters symbols (B) and (S) placed behind the test instruction denotes
(B): carried out 100% inspection at assembly line
(S): carried out test by sampling
- 1.7 The white balance (color temperature), has to be tested in subdued lighted room.
- 1.8 Repetitive power on/ off cycle are allowed. The image can be displayed after 8 sec.
- 1.9 All optical characteristics (including WHITE-D, Brightness, and so on) are determined according to panel specification after warming up approximate 30 minutes that brightness stability is optimal, and follow strictly after panel specification.

2. Input signal

Signal type

- 2.1.1 Analogue Video: 0.7 Vp-p linear, positive polarity
Sync. : TTL level, separate, positive or negative polarity
Signal source: pattern generator format as attachment.(table 1 to 40) Reference generator : QuantumData 802G/ 802BT
- 2.1.2 Digital Video :600mVp-p TMDS Signal
- 2.1.3 Audio Signal : PC line in
- 2.2 Input signal mode
(1) Factory Preset Modes (15modes)

Item	H.Freq. (KHz)	Mode	Resolution	V.Freq. (Hz)	Item	H.Freq. (KHz)	Mode	Resolution	V.Freq. (Hz)
1	31.469	IBM VGA 10H	640x350	70.086	9	48.363	VESA	1024x768	60.004
2	31.469	IBM VGA 3H	720x400	70.087	10	60.023	VESA	1024x768	75.029
3	31.469	IBM VGA 12H	640x480	59.940	11	68.700	MACINTOSH	1152x870	75.000
4	35.000	MACINTOSH	640x480	67.000	12	63.981	VESA	1280x1024	60.020
5	37.500	VESA	640x480	75.000	13	79.976	VESA	1280x1024	75.025
6	35.156	VESA	800x600	56.250	14	75.0	VESA	1600x1200	60
7	37.879	VESA	800x600	60.317	15	65.29	-	1680x1050	60.0
8	46.875	VESA	800x600	75.000					

(2) Preset Modes (40modes)

Item	H.Freq. (KHz)	Mode	Resolution	V.Freq. (Hz)	Item	H.Freq. (KHz)	Mode	Resolution	V.Freq. (Hz)
1	31.469	IBM VGA 10H	640x350	70.086	22	60.289	CVT 2.3MA	1280 x768	75
2	31.469	IBM VGA 3H	720x400	70.087	23	54.1		1152x864	60
3	31.469	IBM VGA 12H	640x480	59.940	24	63.851	VESA	1152x864	70.012
4	35.000	MACINTOSH	640x480	67.000	25	67.500	VESA	1152x864	75.000
5	37.861	VESA	640x480	72.809	26	68.700	MACINTOSH	1152x870	75.000
6	37.500	VESA	640x480	75.000	27	61.845	SUN WS	1152x900	66.004
7	43.269	VESA	640x480	85.008	28	71.810	SUN WS	1152x900	76.150
8	35.156	VESA	800x600	56.250	29	60.000	VESA	1280x960	60.000
9	37.879	VESA	800x600	60.317	30	75.000	VESA	1280x960	75.000
10	48.077	VESA	800x600	72.188	31	63.981	VESA	1280x1024	60.020
11	46.875	VESA	800x600	75.000	32	71.691	SUN WS	1280x1024	67.189
12	53.674	VESA	800x600	85.061	33	76.000	DOS/V	1280x1024	72.000
13	49.700	MACINTOSH	832x624	75.000	34	79.976	VESA	1280x1024	75.025
14	56.4	-	960x720	75	35	81.130	SUN WS	1280x1024	76.110
15	44.75	-	960x720	60	36	91.1	VESA	1280x1024	85.0
16	48.363	VESA	1024x768	60.004	37	78.36	CVT 2.3MA	1600x1000	75.0 (for D-Sub)

17	56.476	VESA	1024x768	70.069	38	75.0	VESA	1600x1200	60.0
18	60.023	VESA	1024x768	75.029	39	65.29	VESA	1680*1050	59.883
19	61.080	IBM XGA-2	1024x768	75.781	40	82.306	VESA	1680*1050	74.892
20	68.677	VESA	1024x768	84.997	41				
21	47.776	CVT 2.3MA	1280 x768	60	42				

3. AC, DC power board

- 3.1 Setup the AC I/P at 90VAC, and Output DC 12V loading 1.1A(AU 0.6A), the DC output voltage is 12.0 ± 0.6 V DC, Adjusting is no need. and 5V loading 1.0A(AU 2.7A), the DC output voltage is $5V \pm 0.25$ VDC. (B)

4. Display Adjustment

- 4.1 Access to factory mode (IIC) in auto-alignment system The communication protocol switch to IIC .

4.2 Auto color adjustment (B)

Apply a 1280x1024/60Hz signal with Black and white levels pattern, set brightness control at 100%, and contrast control at 50%. Adjust the R, G, B offset, and gain to calibrate the color smoothly and 64-gray level distinguishable. Check all factory pre-setting modes.

4.3 Adjustment of WHITE-D (B)

Apply a 1280*1024 / 60Hz signal with white pattern, set brightness control at 100%, and contrast control at 50%. Adjust the R, G, B Sub-Gain, for the screen center, the 1931 CIE chromaticity (X, Y) co-ordinates shall be;

	9300°K	6500°K
x (center)	0.283 ± 0.005	0.313 ± 0.005
y (center)	0.297 ± 0.005	0.329 ± 0.005

Use Minolta CA-110 for colour coordinates and luminance check.

Luminance is > 200 Nits in the center of the screen when brightness at 100% and contrast set to 100%.

4.4 Adjustment of sRGB

Apply a 1280*1024 / 60Hz signal with white pattern, set brightness control at 100%, and contrast control at 50%. Adjust the R, G, B Sub-Gain, for the screen center, the 1931 CIE chromaticity (X, Y) co-ordinates shall be;

	sRGB
x(center)	0.313 ± 0.008
y(center)	0.329 ± 0.008
Ynits	180 ± 10

4.5 Factory Preset (B):

4.5.1

After finished all the adjustment, set:

OSD Default Setting:

Brightness: 100%

Contrast: 50%

Adjust size: Full screen

Language: English

Colour: 6500K for IMAGE MANAGEMENT

OSD position: middle of the LCD screen

Input Selection: Default as PC VGA (D-sub)

4.5.2

In Factory mode default setting :

SECURITY : OFF

SUB-BRI : 0 235 (Fix)

SUB-CON : 78 128 178 (Fix)

PANEL: QDI

General

DDC Data Re-programming

In case the DDC data memory IC or main EEPROM which storage all factory settings were replaced due to a defect, the serial numbers have to be re-programmed "Analog DDC IC, Digital DDC IC & EEPROM". It is advised to re-soldered DDC IC and main EEPROM from the old board onto the new board if circuit board have been replaced, in this case the DDC data does not need to be re-programmed.

Additional information

Additional information about DDC (Display Data Channel) may be obtained from Video Electronics Standards Association (VESA). Extended Display Identification Data(EDID) information may be also obtained from VESA.

System and equipment requirements

1. An i486 (or above) personal computer or compatible.
2. Microsoft operation system Windows 95/98 .
You have to Install the EDID_PORT_Tool under Win2000/XP . As Fig. 1 .

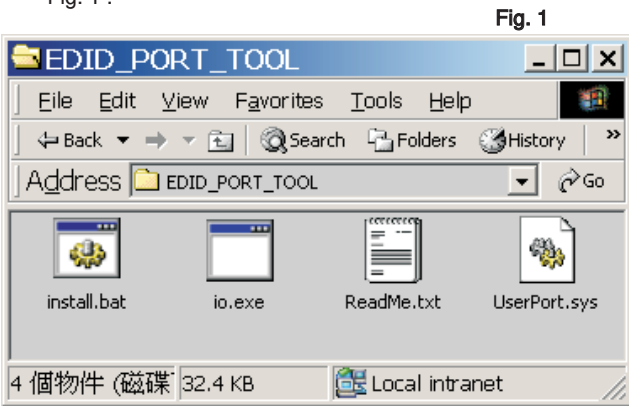

Fig. 1

- A. Copy the "UserPort.sys" to C:\WINNT\system32\drivers(win2000)
C:\WINDOWS\system32\drivers(winXP)

- B. Running " io.exe" everytime, Before you start to programming edid data .

3. EDID46.EXE program
4. A/D Alignment kits (12NC: 3138 106 10396):
inclusion : a. Alignment box x1 (Fig. 2)

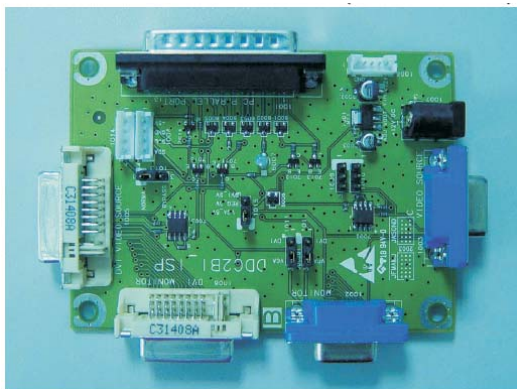

Fig. 2

- b. Printer cable x1
c. (D-Sub) to (D-Sub) cable x1
D. (D-Sub) to (DVI) cable x1

Note: The alignment box has already build-in a batteries socket for using batteries (8~12V) as power source. Pull out the socket by remove four screws at the rear of box. Please do not forget that remove batteries after programming. The energy of batteries can only drive circuits for a short period of time.

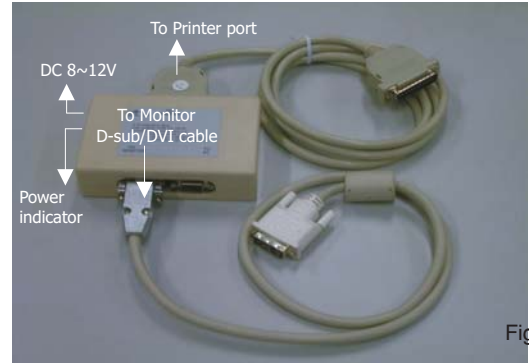
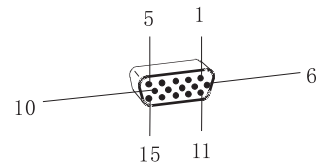

Fig. 3

Pin assignment

A. 15-pin D-Sub Connector



PIN No.	SIGNAL
1	Red video input
2	Green video input / sync on green
3	Blue video input
4	GND
5	GND - Cable detect
6	Red video GND
7	Green video GND
8	Blue video ND
9	DDC +3.3V or +5V
10	Logic GND
11	GND
12	Serial data line (SDA)
13	H-sync / H+V
14	V-sync
15	Data clock line (SCL)

B. Input DVI -D Connector pin

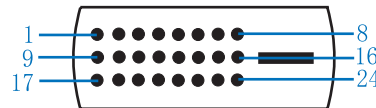

Pin No.	Description
1	T.M.D.S. data2-
2	T.M.D.S. data2+
3	T.M.D.S. data2 shield
4	No Connect
5	No Connect
6	DDC clock
7	DDC data
8	No Connect
9	T.M.D.S. data1-
10	T.M.D.S. data1+
11	T.M.D.S. data1 shield
12	No Connect
13	No Connect
14	+5V Power
15	Ground (for +5V) - Cable detect
16	Hot plug detect
17	T.M.D.S. data0-
18	T.M.D.S. data0+
19	T.M.D.S. data0 shield
20	No Connect
21	No Connect
22	T.M.D.S. clock shield
23	T.M.D.S. clock+
24	T.M.D.S. clock-

Configuration and procedure

There is no Hardware DDC (DDC IC) anymore. Main EEPROM stores all factory settings and DDC data (EDID code) which is also called Software DDC. The following section describes the connection and procedure for Software DDC application. The main EEPROM can be re-programmed by enabling "factory memory data write" function on the DDC program (EDID46.EXE).

Initialize alignment box

In order to avoid that monitor entering power saving mode due to sync will cut off by alignment box, it is necessary to initialize alignment box before running programming software (EDID46.EXE). Following steps show you the procedures and connection.

Step 1: Supply 8-12V DC power source to the Alignment box by plugging a DC power cord .

Step 2: Connecting printer cable and D-Sub cable of monitor as Fig. 4

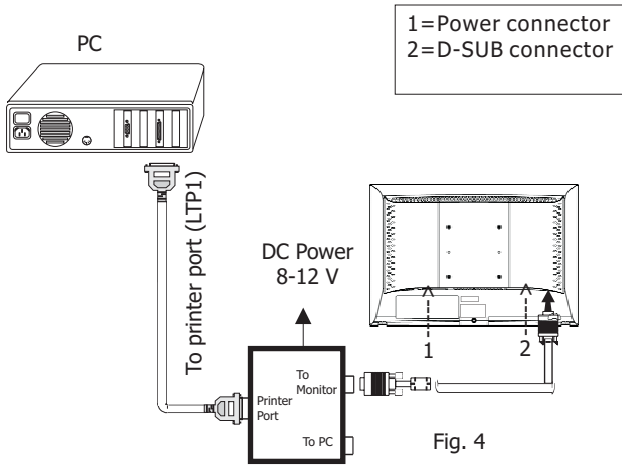

Fig. 4

Step 3: Installation of EDID46.EXE

Method 1: Start on DDC program

Start Microsoft Windows.

1. The Program "EDID46.EXE" in service manual cd-rom be copied to C:\.
2. Click **Start**, choose Run at start menu of Windows as shown in Fig. 5.

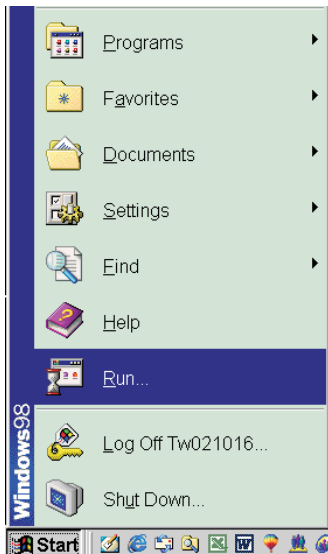

Fig. 5

3. At the submenu, type the letter of your computer's hard disk drive followed by :EDID46 (for example, C:\EDID46, as shown in Fig. 6).

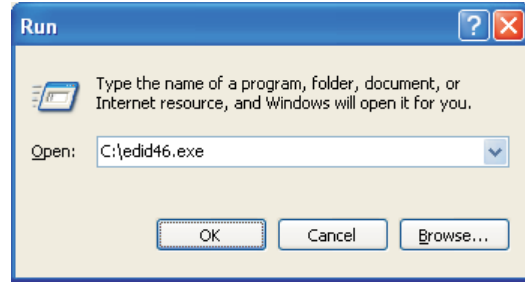

Fig. 6

4. Click OK button. The main menu appears (as shown in Fig. 7). This is for initialize alignment box.

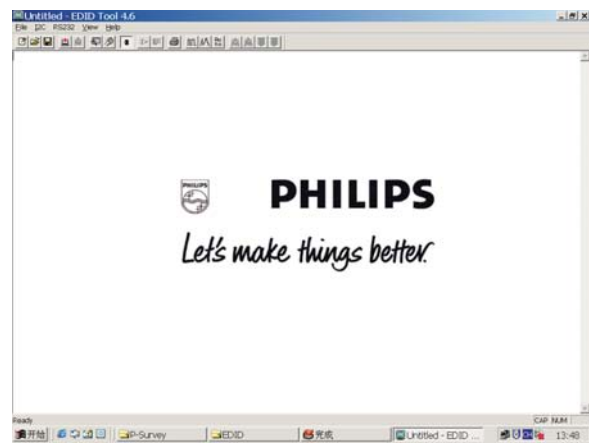

Fig. 7

Note 1: If the connection is improper, you will see the following error message (as shown in Fig. 8) before entering the main menu. Meanwhile, the (read EDID) function will be disable. At this time, please make sure all cables are connected correctly and fixedly, and the procedure has been performed properly.

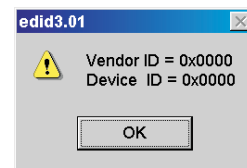

Fig. 8

Note 2: During the loading, EDID46 will verify the EDID data which just loaded from monitor before proceed any further function, once the data structure of EDID can not be recognized, the following error message will appear on the screen as below. Please confirm following steps to avoid this message.

1. The data structure of EDID was incorrect.
2. DDC IC that you are trying to load data is empty.
3. Wrong communication channel has set at configuration setup windows.
4. Cables loosed or poor contact of connection.



Fig. 9

Re-programming Analog DDC IC

Step 1: After initialize alignment box, connecting all cables and box as shown in Fig. 10.

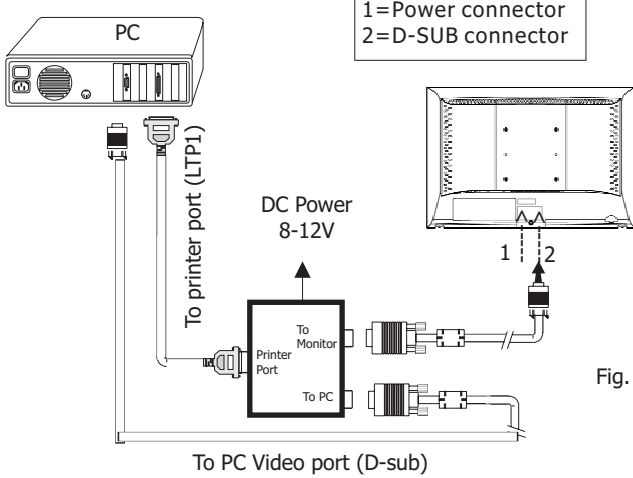

Fig. 10

Step 2: Read DDC data from monitor

1. Click icon as shown in Fig. 11 from the tool bar to bring up the Channels "Configuration Setup" windows as shown in Fig. 11.

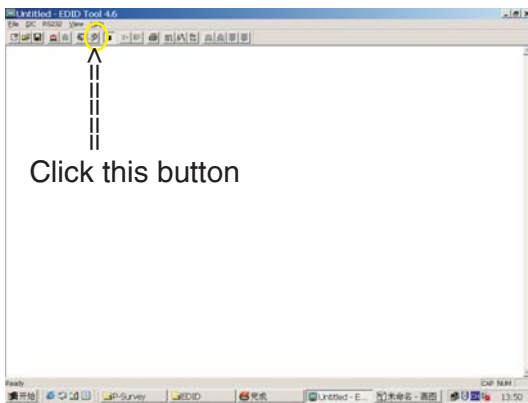

Fig. 11

2. Select the DDC2Bi as the communication channel. As shown in Fig. 12.

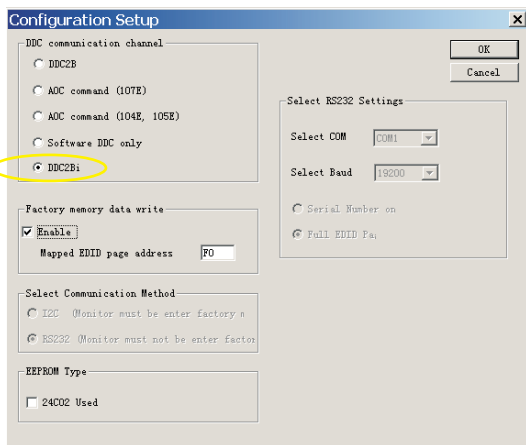

Fig. 12

3. Click OK button to confirm your selection.
4. Click icon (Read EDID function) to read DDC EDID data from monitor. The EDID codes will display on screen as shown in Fig. 13.

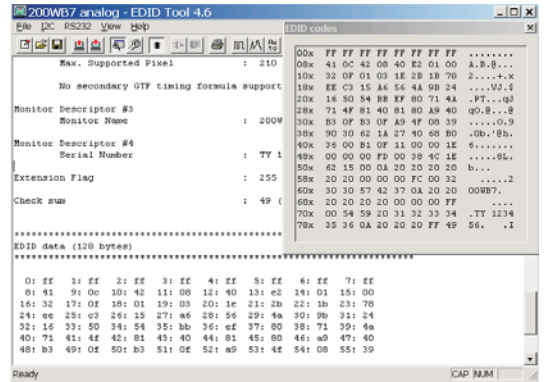

Fig. 13

Step 3: Modify DDC data (verify EDID version, week, year)

- Click (new function) icon from the tool bar, bring up Step 1 of 9 as shown in Fig. 14. EDID46 DDC application provides the function selection and

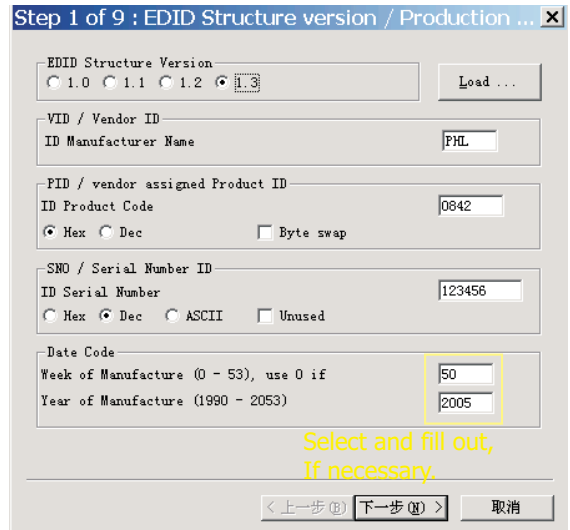

Fig. 14

Step 4: Modify DDC data (Monitor Serial No.)

1. Click Next, bring up Fig. 15.

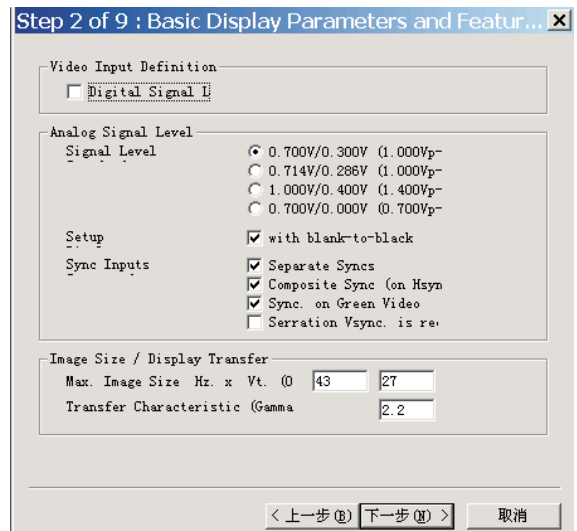

Fig. 15

DDC Instructions

2. Click Next , bring up Fig.16.

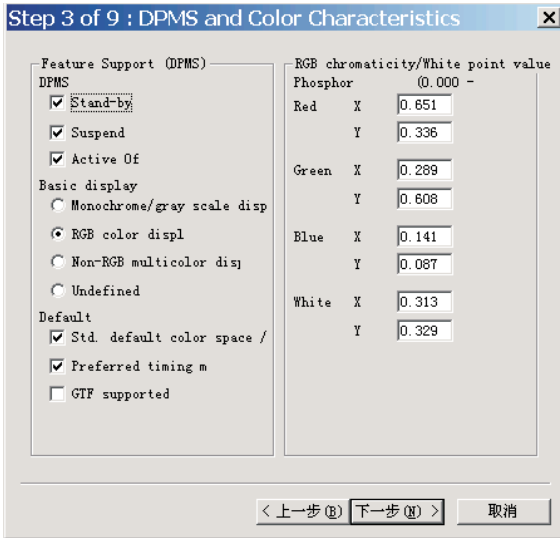

Fig. 16

3. Click Next , bring up Fig.17.

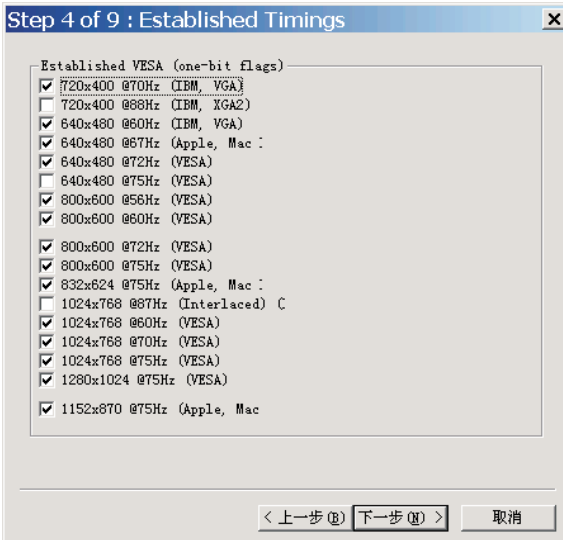

Fig. 17

4. Click Next , bring up Fig.18.

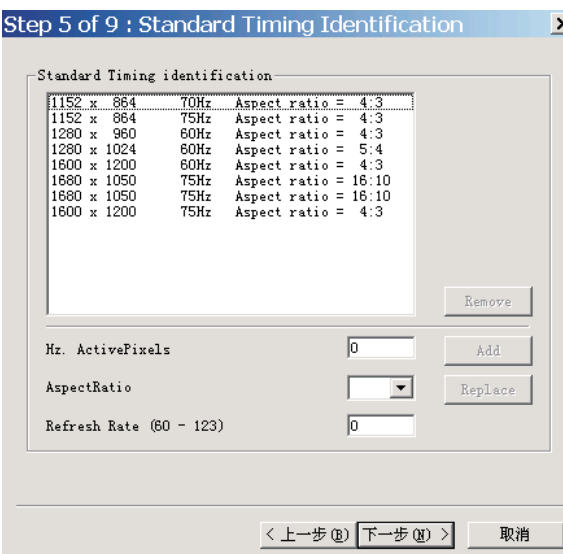

Fig. 18

5. Click Next , bring up Fig.19.

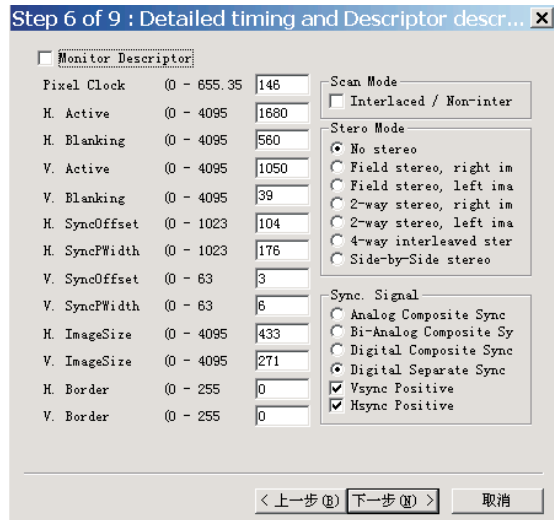

Fig. 19

6. Click Next , bring up Fig. 20.

In this step, please confirm the Descriptor Data Type is Monitor Range Limits, and all the items are same as below.

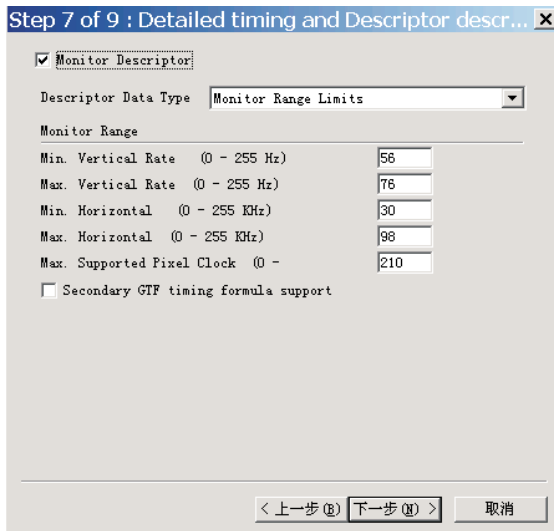

Fig. 20

7. Click Next , bring up Fig. 21.

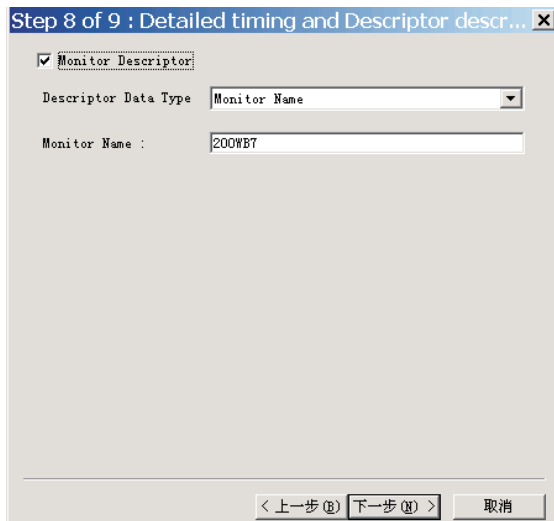

Fig. 21

- Click Next , bring up Fig. 22.
 - Click Finish to exit the Step window.
 - Serial number can be filled up at this moment (for example, TY 123456).

NOTE: You must modify the Serial NO. In step 9, otherwise the Serial NO. In OSD Couldn't be modified correctly.

Step 5: Write DDC data

- Configuration should be as Fig. 23. And press OK.

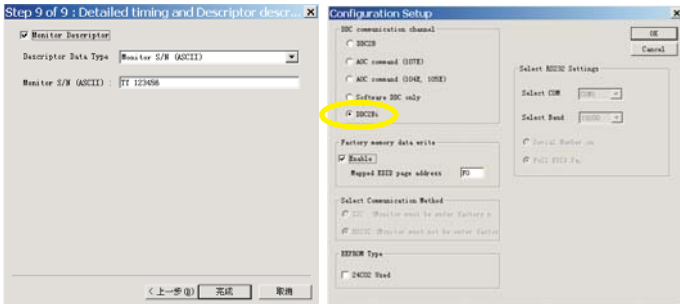

Fig. 22

Fig. 23

2. Access Factory Mode

- Turn off monitor.
- [Push "AUTO" & "OK" buttons at the same time and hold them] + [Press "power" button until comes out "Windows screen"] => then release all buttons
- Press "OK" button, wait until the OSD menu with Characters "HUDSON 200WB7 V011 2006/02/16" (below OSD menu) come on the Screen of the monitor. as shown in Fig24.

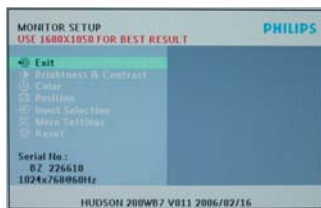

Fig. 24

Factory Mode indicator

- Push "Menu" to exit OSD menu.
- Click (Write EDID) icon from the tool bar to write DDC data. Then wait for 20-30 seconds ,DDC data will be finished Writing.

Step 6: Save DDC data

Sometimes, you may need to save DDC data as a text file for using in other IC chip. To save DDC data, follow the steps below:

- Click (Save) icon (or click "file"-> "save as") from the tool bar and give a file name as shown in Fig. 25. The file type is EDID46 file (*.ddc) which can be open in WordPad. By using WordPad, the texts of DDC data & table (128 bytes, hex code) can be modified. If DDC TEXTS & HEX Table are completely correct, it can be saved as .ddc file to re-load it into DDC IC for DDC Data application.

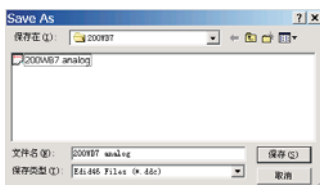

Fig. 25

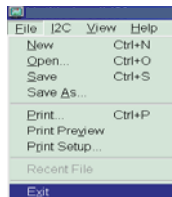

Fig. 26

- Click Save.

Step 7: Exit DDC program

Pull down the File menu and select Exit as shown in Fig. 26.

Step 8: Modify serial number in OSD

- Unzip the serial number.zip to your computer, then open the folder as shown in Fig.27.
- If use Win98 OS, you can execute SN.exe directly. If use Win2000 or XP OS, first, you must execute install.bat, then execute SN.exe
- Set I2C bus (press the left-top button of operating window) as shown in Fig.28, then press " SET" button.
- Set Block2 as shown in Fig.29
- key in new serial number, then press " Write" button as shown in Fig.29 , Click " WRITE" button.
- It will appear "Serial Number Write OK" , Click "Enter" to finish it.

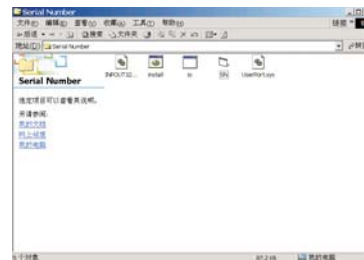

Fig.27

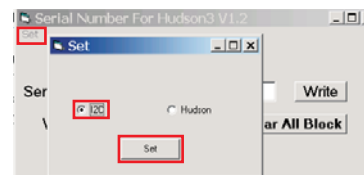

Fig.28



Fig.29

Step9:

- Disconnect the monitor power cord and connect it again.
- Press the OK button to bring up the OSD main manu.
- Re-confirm the serial Number is updated as shown in Fig.30.

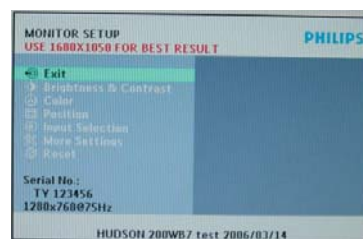

Fig.30

Re-programming Digital DDC IC

Step 1: After initialize alignment box, connecting all cables and box as shown in Fig. 31.

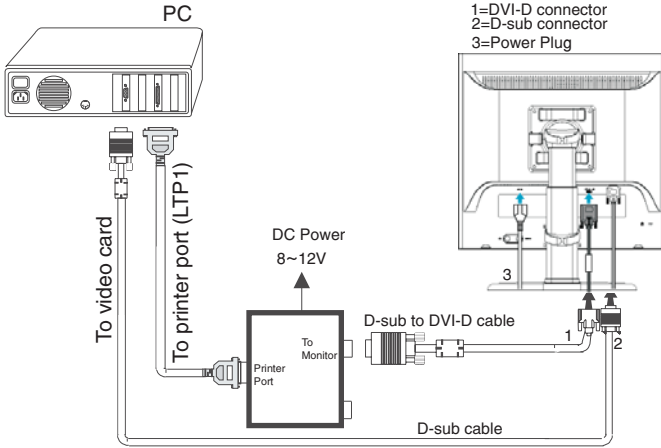

Fig. 31

Step 2: Read DDC data from monitor

1. Click icon as shown in Fig. 11 from the tool bar to bring up the Channels "Configuration Setup" windows as shown in Fig. 32.

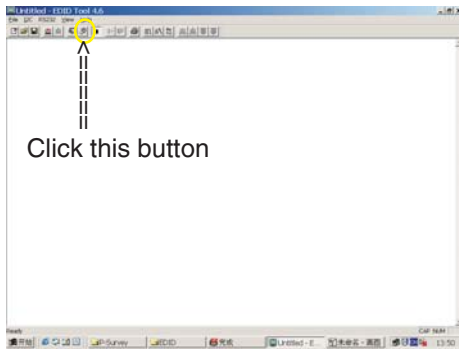

Fig. 32

2. Select the DDC2Bi as the communication channel. As shown in Fig. 33.

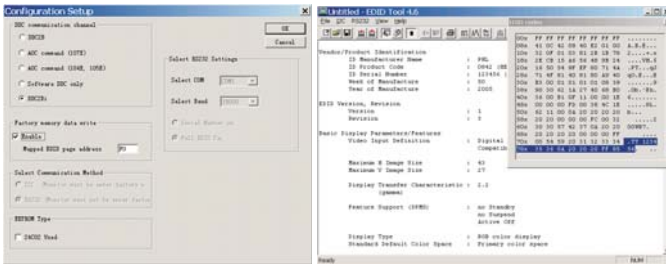

Fig. 33

Fig. 34

3. Click OK button to confirm your selection.
4. Click icon (Read EDID function) to read DDC EDID data from monitor. The EDID codes will display on screen as shown in Fig. 34.

Step 3: Modify DDC data (verify EDID version, week, year)

Click (new function) icon from the tool bar, bring up Step 1 of 9 as shown in Fig. 35. EDID46 DDC application provides the function selection and text change (select & fill out) from Step 1 to Step 9.

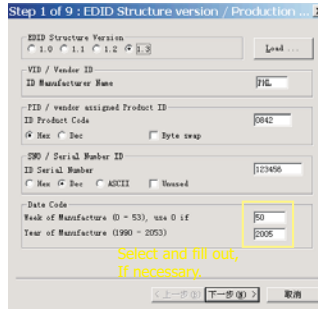

Fig. 35

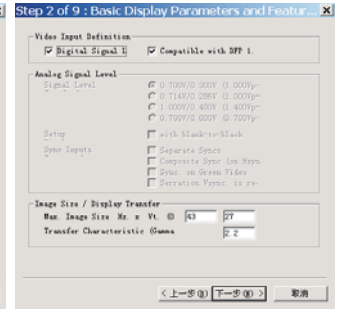

Fig. 36

Step 4: Modify DDC data (Monitor Serial No.)

1. Click Next, bring up Fig. 36.
2. Click Next, bring up Fig. 37.
3. Click Next, bring up Fig. 38.

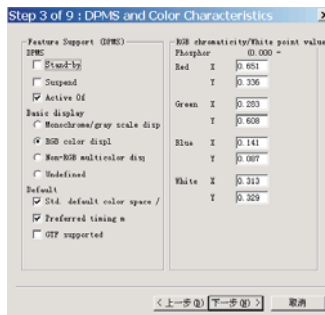

Fig. 37

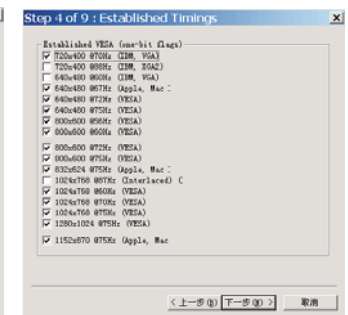

Fig. 38

4. Click Next, bring up Fig. 39.
5. Click Next, bring up Fig. 40.

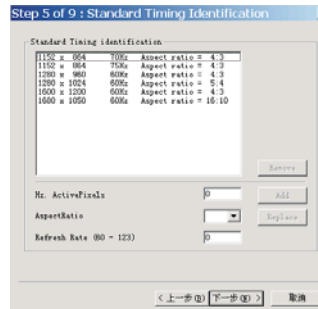

Fig. 39



Fig. 40

6. Click Next, bring up Fig. 41. In this step, please confirm the Descriptor Data Type is Monitor Range Limits, and all the items are same as below.
7. Click Next, bring up Fig. 42.

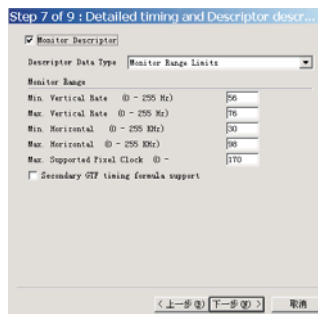

Fig. 41



Fig. 42

8. Click Next , bring up Fig. 43.
 - Click Finish to exit the Step window.
 - Serial number can be filled up at this moment (for example, TY 123456).

NOTE: You must modify the Serial NO. In step 9, otherwise the Serial NO. In OSD Couldn't be modified correctly.



Fig. 43

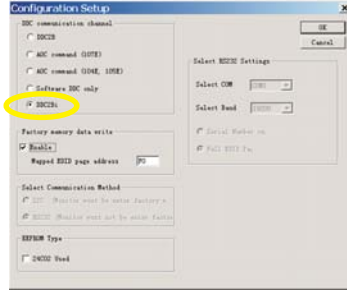
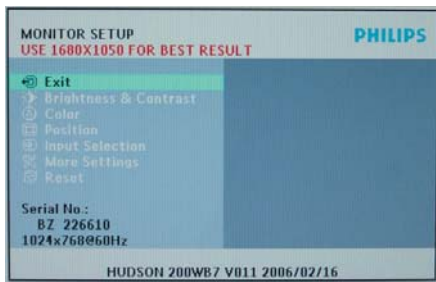

Fig. 44

Step 5: Write DDC data

1. Configuration should be as Fig. 40. And press OK.
2. Access Factory Mode

- 1). Turn off monitor.
- 2). [Push "AUTO" & "OK" buttons at the same time and hold them] +[Press "power" button until comes out "Windows screen"] => then release all buttons
- 3). Press "OK" button, wait until the OSD menu with Characters "HUDSON 200WB7 V011 2006/02/16" (below OSD menu) come on the Screen of the monitor. as shown in Fig45.



↑
Factory Mode indicator

Fig. 45

- 3) Push "Menu" to exit OSD menu.

3. Click (Write EDID) icon from the tool bar to write DDC data. Then wait for 20-30 seconds ,DDC data will be finished Writing.

Step 6: Save DDC data

Sometimes, you may need to save DDC data as a text file for using in other IC chip. To save DDC data, follow the steps below:

1. Click (Save) icon (or click "file"-> "save as") from the tool bar and give a file name as shown in Fig. 46.

The file type is EDID46 file (*.ddc) which can be open in WordPad. By using WordPad, the texts of DDC data & table (128 bytes, hex code) can be modified. If DDC TEXTS & HEX Table ar completely correct, it can be saved as *.ddc fie to re-load it into DDC IC for DDC Data application.

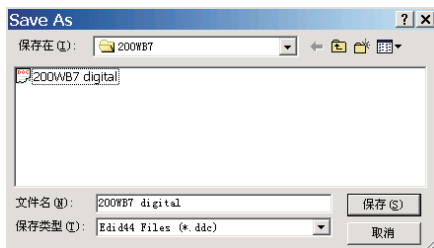

Fig.46

2. Click Save.

Step 7: Exit DDC program

Pull down the File menu and select Exit as shown in Fig. 47.

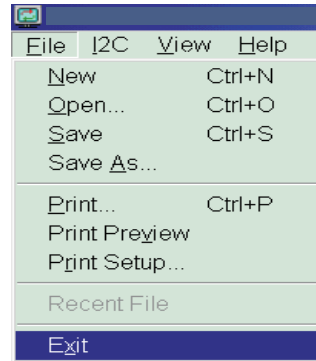
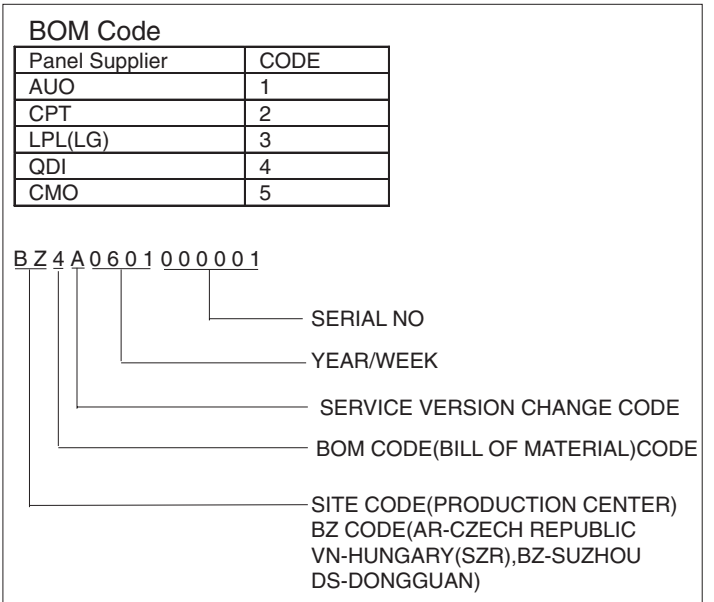
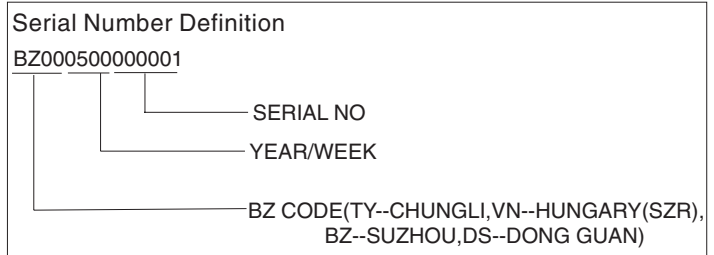

Fig. 47

Step 8: Turn off the monitor, exit the factory mode.



DDC DATA

THE DISPLAY DATA CHANNEL (DDC_2B) CONTENT INCLUDING:
(FOR 200WB7 ANALOG FOR QDI PANEL)

EDID log file

Vendor/Product Identification

ID Manufacturer Name : PHL
ID Product Code : 0842 (HEX.)
ID Serial Number : 123456 (DEC.)
Week of Manufacture : 50
Year of Manufacture : 2005

EDID Version, Revision

Version : 1
Revision : 3

Basic Display Parameters/Features

Video Input Definition : Analog Video Input
0.700V/0.300V (1.00Vpp)
Blank-to-Black Setup
Separate Sync
Composite Sync
Sync on Green
no Serration required

Maximum H Image Size : 43
Maximum V Image Size : 27

Display Transfer Characteristic : 2.2
(gamma)

Feature Support (DPMS) : Standby
Suspend
Active Off

Display Type : RGB color display
Standard Default Color Space : Primary color space
Preferred Timing Mode : Detailed timing block 1

Color Characteristics

Red X coordinate : 0.651
Red Y coordinate : 0.336
Green X coordinate : 0.289
Green Y coordinate : 0.608
Blue X coordinate : 0.141
Blue Y coordinate : 0.087
White X coordinate : 0.313
White Y coordinate : 0.329

Established Timings

Established Timings I : 720 x 400 @ 70Hz (IBM,VGA)
640 x 480 @ 60Hz (IBM,VGA)
640 x 480 @ 67Hz (Apple,Mac II)
640 x 480 @ 72Hz (VESA)
640 x 480 @ 75Hz (VESA)
800 x 600 @ 56Hz (VESA)
800 x 600 @ 60Hz (VESA)

Established Timings II : 800 x 600 @ 72Hz (VESA)
800 x 600 @ 75Hz (VESA)
832 x 624 @ 75Hz (Apple,Mac II)
1024 x 768 @ 60Hz (VESA)
1024 x 768 @ 70Hz (VESA)
1024 x 768 @ 75Hz (VESA)
1280 x 1024 @ 75Hz (VESA)

Manufacturer's timings : 1152 x 870 @ 75Hz (Apple,Mac II)

Standard Timing Identification #1

Horizontal active pixels : 1152
Aspect Ratio : 4:3
Refresh Rate : 70

Standard Timing Identification #2

Horizontal active pixels : 1152
Aspect Ratio : 4:3
Refresh Rate : 75

Standard Timing Identification #3
Horizontal active pixels : 1280
Aspect Ratio : 4:3
Refresh Rate : 60

Standard Timing Identification #4
Horizontal active pixels : 1280
Aspect Ratio : 5:4
Refresh Rate : 60

Standard Timing Identification #5
Horizontal active pixels : 1600
Aspect Ratio : 4:3
Refresh Rate : 60

Standard Timing Identification #6
Horizontal active pixels : 1680
Aspect Ratio : 16:10
Refresh Rate : 60

Standard Timing Identification #7
Horizontal active pixels : 1680
Aspect Ratio : 16:10
Refresh Rate : 75

Standard Timing Identification #8
Horizontal active pixels : 1600
Aspect Ratio : 4:3
Refresh Rate : 75

Detailed Timing #1

Pixel Clock (MHz) : 146
H Active (pixels) : 1680
H Blanking (pixels) : 560
V Active (lines) : 1050
V Blanking (lines) : 39
H Sync Offset (F Porch) (pixels) : 104
H Sync Pulse Width (pixels) : 176
V Sync Offset (F Porch) (lines) : 3
V Sync Pulse Width (lines) : 6
H Image Size (mm) : 433
V Image Size (mm) : 271
H Border (pixels) : 0
V Border (lines) : 0
Flags : Non-interlaced
: Normal Display, No stereo
: Digital Separate sync.
: Positive Vertical Sync.
: Positive Horizontal Sync.

Monitor Descriptor #2

Serial Number : TY 123456

Monitor Descriptor #3

Monitor Name : Philips 200WB

Monitor Descriptor #4

Monitor Range Limits
Min. Vt rate Hz : 56
Max. Vt rate Hz : 76
Min. Horiz. rate kHz : 30
Max. Horiz. rate kHz : 98
Max. Supported Pixel : 210

No secondary GTF timing formula supported.

Extension Flag : 0

Check sum : 59 (HEX.)

EDID data (128 bytes)

0: 00 1: ff 2: ff 3: ff 4: ff 5: ff 6: ff 7: 00
8: 41 9: 0c 10: 42 11: 08 12: 40 13: e2 14: 01 15: 00
16: 32 17: 0f 18: 01 19: 03 20: 1e 21: 2b 22: 1b 23: 78
24: ee 25: c3 26: 15 27: a6 28: 56 29: 4a 30: 9b 31: 24
32: 16 33: 50 34: 54 35: bf 36: ef 37: 80 38: 71 39: 4a
40: 71 41: 4f 42: 81 43: 40 44: 81 45: 80 46: a9 47: 40
48: b3 49: 00 50: b3 51: 0f 52: a9 53: 4f 54: 08 55: 39
56: 90 57: 30 58: 62 59: 1a 60: 27 61: 40 62: 68 63: b0
64: 36 65: 00 66: b1 67: 0f 68: 11 69: 00 70: 00 71: 1e
72: 00 73: 00 74: 00 75: ff 76: 00 77: 20 78: 54 79: 59
80: 20 81: 20 82: 31 83: 32 84: 33 85: 34 86: 35 87: 36
88: 0a 89: 20 90: 00 91: 00 92: 00 93: fc 94: 00 95: 50
96: 68 97: 69 98: 6c 99: 69 100: 70 101: 73 102: 20 103: 32
104: 30 105: 30 106: 57 107: 42 108: 00 109: 00 110: 00 111: fd
112: 00 113: 38 114: 4c 115: 1e 116: 62 117: 15 118: 00 119: 0a
120: 20 121: 20 122: 20 123: 20 124: 20 125: 20 126: 00 127: 59

DDC DATA

THE DISPLAY DATA CHANNEL (DDC_2B) CONTENT INCLUDING:
(FOR 200WB7 DIGITAL FOR QDI PANEL)

EDID log file

Vendor/Product Identification

ID Manufacturer Name : PHL
ID Product Code : 0842 (HEX.)
ID Serial Number : 123456 (DEC.)
Week of Manufacture : 50
Year of Manufacture : 2005

EDID Version, Revision

Version : 1
Revision : 3

Basic Display Parameters/Features

Video Input Definition : Digital Video Input
Compatible with VESA DFP 1.x

Maximum H Image Size : 43
Maximum V Image Size : 27

Display Transfer Characteristic : 2.2
(gamma)

Feature Support (DPMS) : no Standby
no Suspend
Active Off

Display Type : RGB color display
Standard Default Color Space : Primary color space
Preferred Timing Mode : Detailed timing block 1

Color Characteristics

Red X coordinate : 0.651
Red Y coordinate : 0.336
Green X coordinate : 0.289
Green Y coordinate : 0.608
Blue X coordinate : 0.141
Blue Y coordinate : 0.087
White X coordinate : 0.313
White Y coordinate : 0.329

Established Timings

Established Timings I : 720 x 400 @ 70Hz (IBM,VGA)
640 x 480 @ 60Hz (IBM,VGA)
640 x 480 @ 67Hz (Apple,Mac II)
640 x 480 @ 72Hz (VESA)
640 x 480 @ 75Hz (VESA)
800 x 600 @ 56Hz (VESA)
800 x 600 @ 60Hz (VESA)

Established Timings II : 800 x 600 @ 72Hz (VESA)
800 x 600 @ 75Hz (VESA)
832 x 624 @ 75Hz (Apple,Mac II)
1024 x 768 @ 60Hz (VESA)
1024 x 768 @ 70Hz (VESA)
1024 x 768 @ 75Hz (VESA)
1280 x 1024 @ 75Hz (VESA)

Manufacturer's timings : 1152 x 870 @ 75Hz (Apple,Mac II)

Standard Timing Identification #1

Horizontal active pixels : 1152
Aspect Ratio : 4:3
Refresh Rate : 70

Standard Timing Identification #2

Horizontal active pixels : 1152
Aspect Ratio : 4:3
Refresh Rate : 75

Standard Timing Identification #3

Horizontal active pixels : 1280
Aspect Ratio : 4:3
Refresh Rate : 60

Standard Timing Identification #4

Horizontal active pixels : 1280
Aspect Ratio : 5:4
Refresh Rate : 60

Standard Timing Identification #5

Horizontal active pixels : 1600
Aspect Ratio : 4:3
Refresh Rate : 60

Standard Timing Identification #6

Horizontal active pixels : 1680
Aspect Ratio : 16:10
Refresh Rate : 60

Detailed Timing #1

Pixel Clock (MHz) : 146
H Active (pixels) : 1680
H Blanking (pixels) : 560
V Active (lines) : 1050
V Blanking (lines) : 39
H Sync Offset (F Porch) (pixels) : 104
H Sync Pulse Width (pixels) : 176
V Sync Offset (F Porch) (lines) : 3
V Sync Pulse Width (lines) : 6
H Image Size (mm) : 433
V Image Size (mm) : 271
H Border (pixels) : 0
V Border (lines) : 0
Flags : Non-interlaced
: Normal Display, No stereo
: Digital Separate sync.
: Positive Vertical Sync.
: Positive Horizontal Sync.

Monitor Descriptor #2

Serial Number : TY 123456

Monitor Descriptor #3

Monitor Name : Philips 200WB

Monitor Descriptor #4

Monitor Range Limits
Min. Vt rate Hz : 56
Max. Vt rate Hz : 76
Min. Horiz. rate kHz : 30
Max. Horiz. rate kHz : 98
Max. Supported Pixel : 170

No secondary GTF timing formula supported.

Extension Flag : 0

Check sum : 70 (HEX.)

EDID data (128 bytes)

0: 00 1: ff 2: ff 3: ff 4: ff 5: ff 6: ff 7: 00
8: 41 9: 0c 10: 42 11: 08 12: 40 13: e2 14: 01 15: 00
16: 32 17: 0f 18: 01 19: 03 20: 81 21: 2b 22: 1b 23: 78
24: 2e 25: c3 26: 15 27: a6 28: 56 29: 4a 30: 9b 31: 24
32: 16 33: 50 34: 54 35: bf 36: ef 37: 80 38: 71 39: 4a
40: 71 41: 4f 42: 81 43: 40 44: 81 45: 80 46: a9 47: 40
48: b3 49: 00 50: 01 51: 01 52: 01 53: 01 54: 08 55: 39
56: 90 57: 30 58: 62 59: 1a 60: 27 61: 40 62: 68 63: b0
64: 36 65: 00 66: b1 67: 0f 68: 11 69: 00 70: 00 71: 1e
72: 00 73: 00 74: 00 75: ff 76: 00 77: 20 78: 54 79: 59
80: 20 81: 20 82: 31 83: 32 84: 33 85: 34 86: 35 87: 36
88: 0a 89: 20 90: 00 91: 00 92: 00 93: fc 94: 00 95: 50
96: 68 97: 69 98: 6c 99: 69 100: 70 101: 73 102: 20 103: 32
104: 30 105: 30 106: 57 107: 42 108: 00 109: 00 110: 00 111: fd
112: 00 113: 38 114: 4c 115: 1e 116: 62 117: 11 118: 00 119: 0a
120: 20 121: 20 122: 20 123: 20 124: 20 125: 20 126: 00 127: 70

Configuration and procedure

"Easywriter " The software is provided by Novatek to upgrade the firmware of CPU.
 It is a windows-based program, which cannot be run in MS-DOS.
 DDC2BI_ISP TOOL (3138 149 53161) is for the interface between "Parallel Port of PC" and "15 pin-D-SUB connector of Monitor".

System and equipment requirements

1. An i486 (or above) personal computer or compatible.
2. Microsoft operation system Windows 95/98/2000/XP.
3. ISP Software " Easywrite "
4. DDC2BI_ISP TOOL (3138 106 10396) as shown in Fig. 1

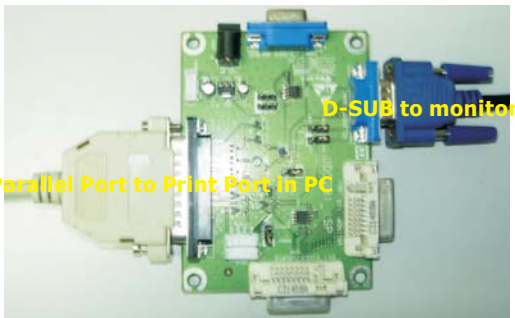

Fig. 1

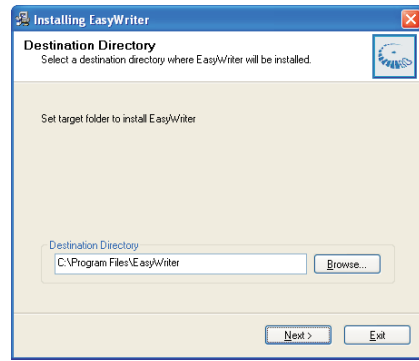

Fig. 4

Step 5 :Copy the Philips_H200WB_EU_QDI201_test to C:\200WB7 as shown in Fig. 5 .

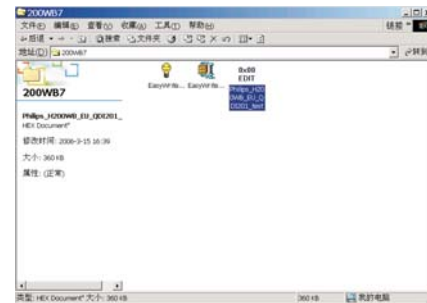

Fig. 5

5. Connect DDC2BI_ISP TOOL and Mains cord to Monitor as shown in Fig. 2.

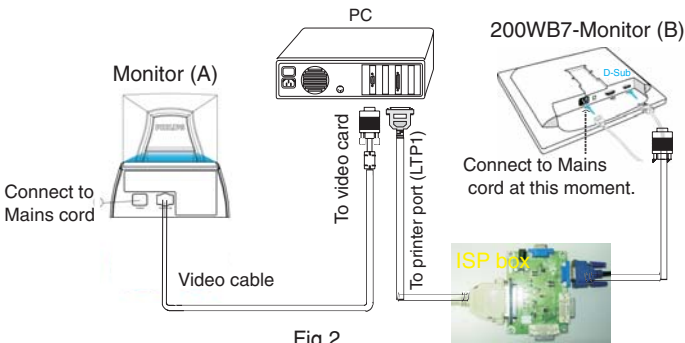

Fig.2

6. Install and setup the Easywriter program

- Step 1 : Make a folder in your PC as shown in Fig. 3.
For example : C:\200WB7
- Step 2 : Copy ISP Software Easywriter.zip into your folder as shown in Fig.3.
- Step 3 : Unzip Easywriter.zip into your folder as shown in Fig. 3.
- Step 4 : Double click the EasywriterV2.09a_user.exe icon to install the Application as Fig. 4.

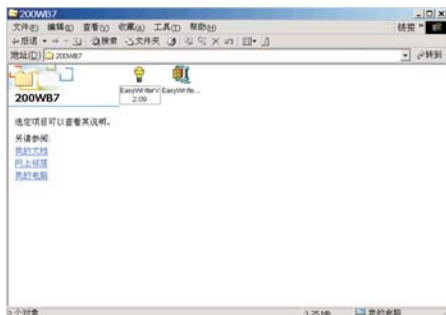

Fig. 3

Update the firmware

1. Double click the Easywriter.exe icon in desktop then appears window as shown in Fig.7 .



Fig. 6

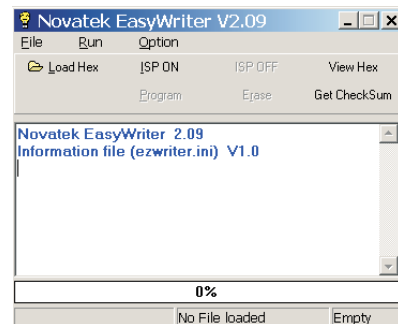

Fig. 7

2. Press the Load hex then select the hex as shown in Fig. 8.

ISP Instructions

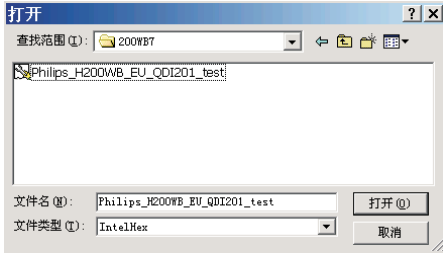

Fig. 8

3 Press the AUTO to running program , the firmware be updated as shown in Fig. 9~10.

If there is a warning message coming as shown in Fig 12. , you have to check the AC power, Video cable, or Novatek MCU.

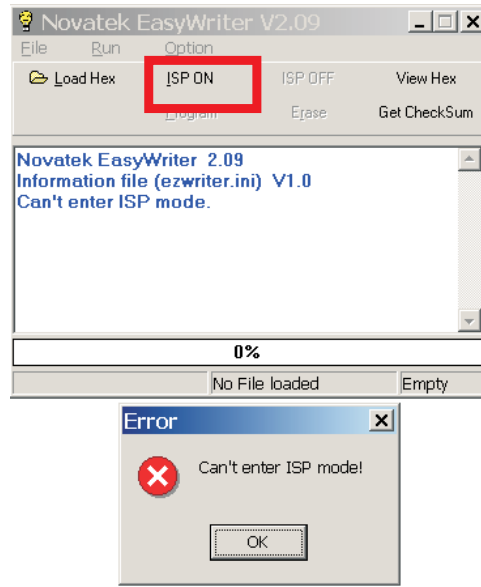

Fig. 12

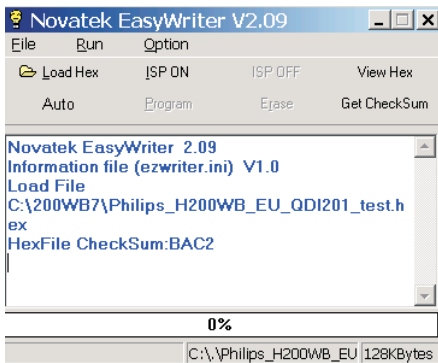

Fig. 9

5 Check the firmware version

- 1). Turn off monitor.
- 2). [Push "AUTO" & "OK" buttons at the same time and hold them] +[Press "power" button until comes out "Windows screen"] => then release all buttons.
- 3). Press "OK" button, wait until the OSD menu come on the Screen of the monitor. You will find, after upgrade, the version have already changed from The former "HUDSON 200WB7 V011 2006/02/16" to the Present "HUDSON 200WB7 test 2006/03/14" as shown in Fig. 13 and Fig. 14.

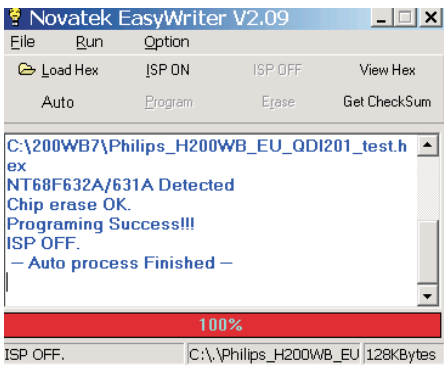
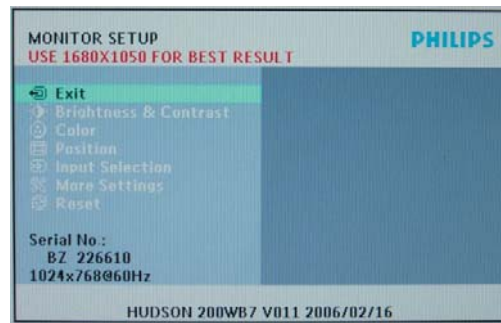

Fig. 10



Factory Mode indicator

Fig. 13

4 Press the file --> exit to end program , as shown in Fig. 11.

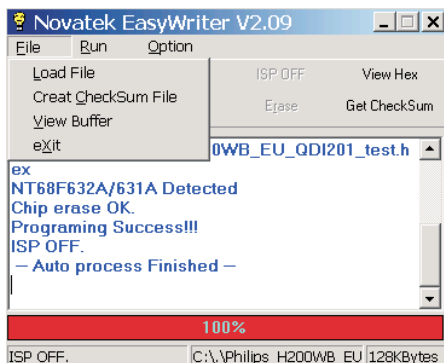
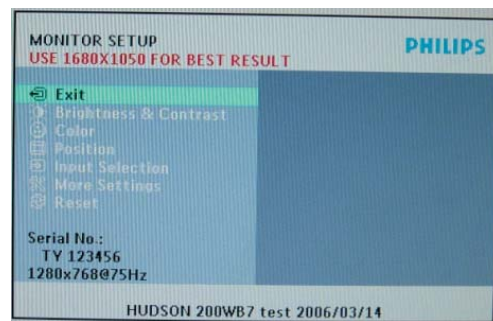

Fig. 11



Factory Mode indicator

Fig. 14

4) Turn off the monitor, exit the factory mode.

Wiring Diagram

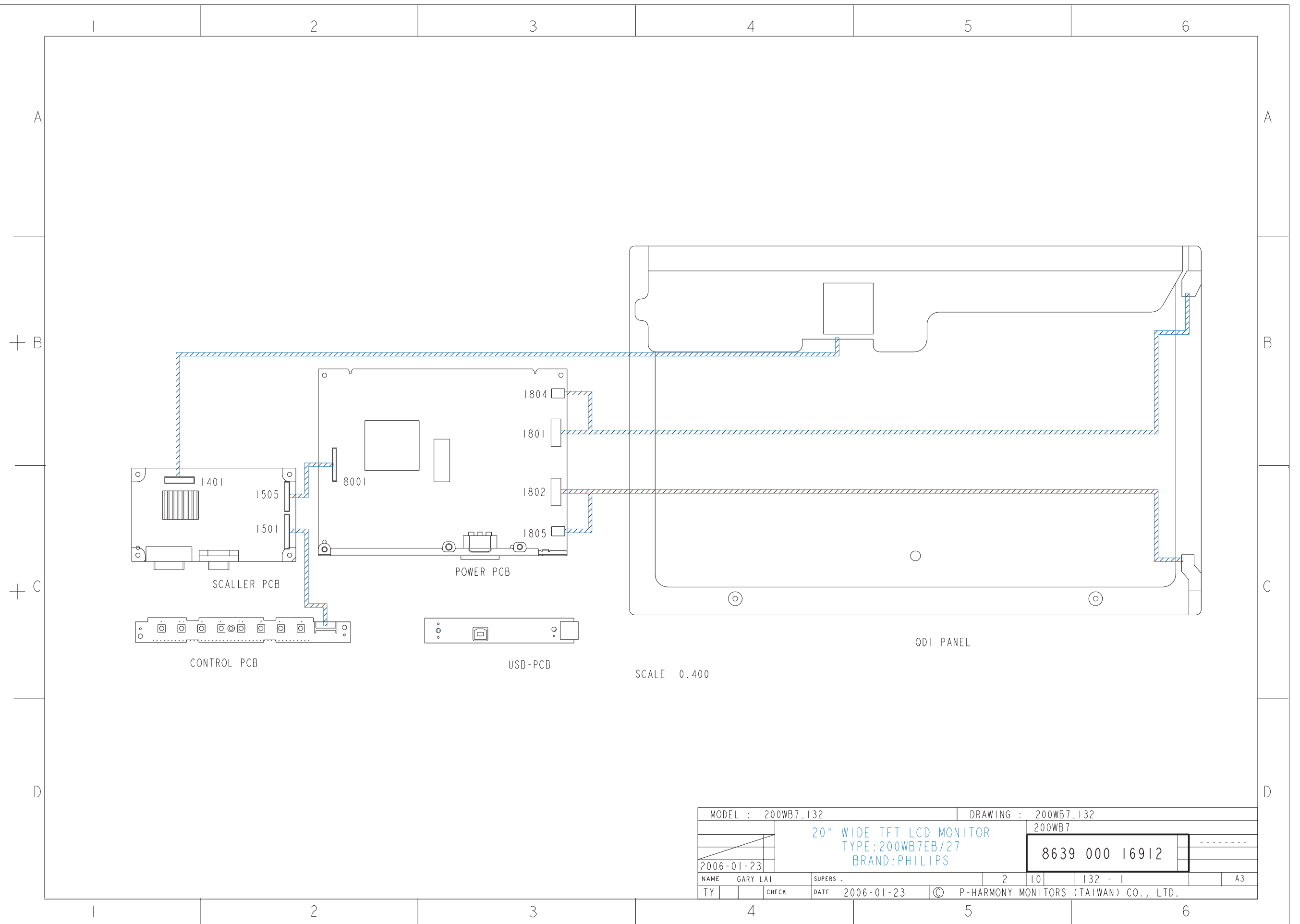

SCALE 0.400

MODEL : 200WB7_132		DRAWING : 200WB7_132	
		200WB7	
2006-01-23		8639 000 16912	
NAME	GARY LAI	SUPERS	2 10 132 - 1 A3
TY	CHECK	DATE	2006-01-23 © P-HARMONY MONITORS (TAIWAN) CO., LTD.

Block Diagram

200WB7 Scalar Board Block Diagram

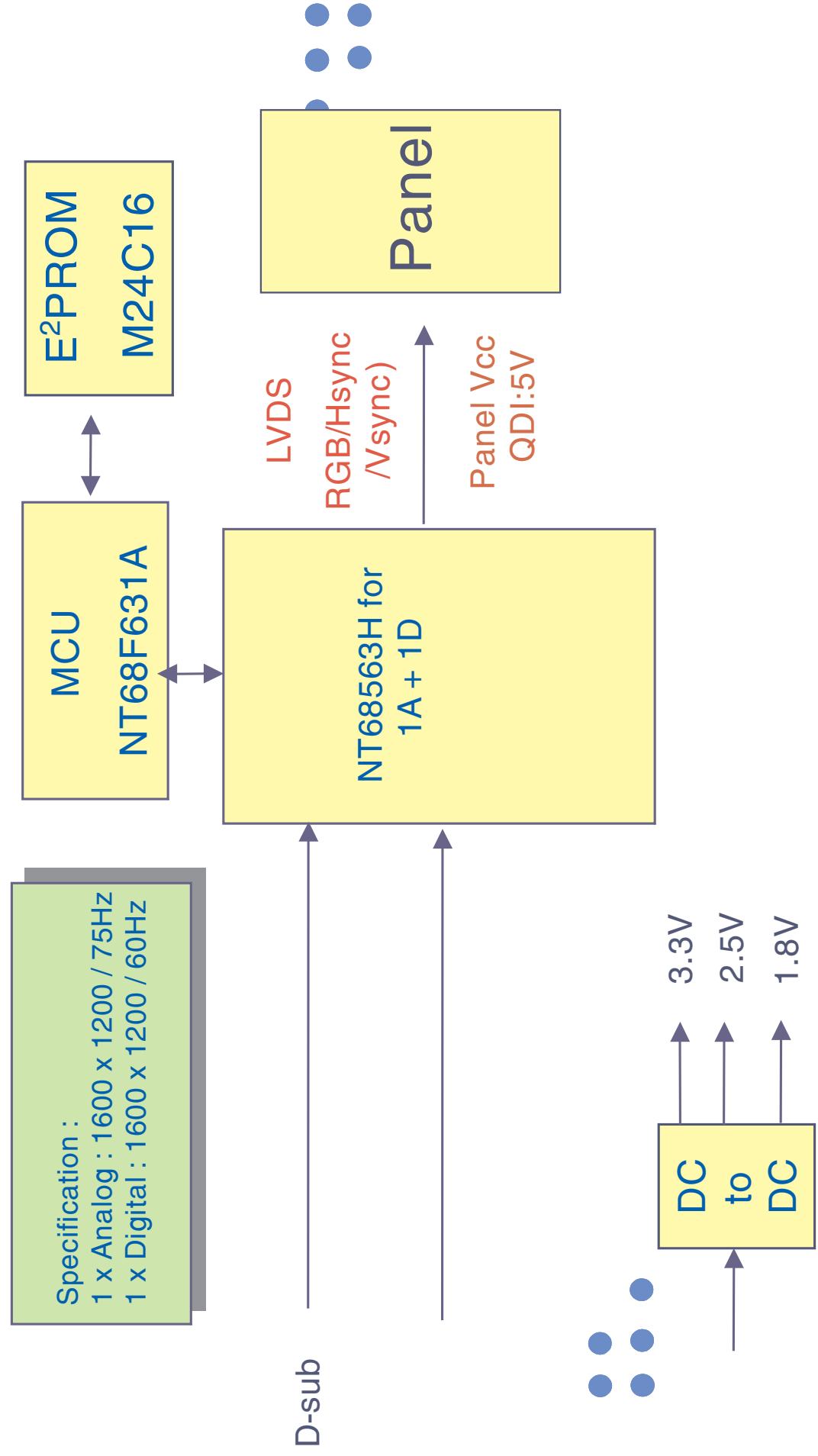

USB Plug

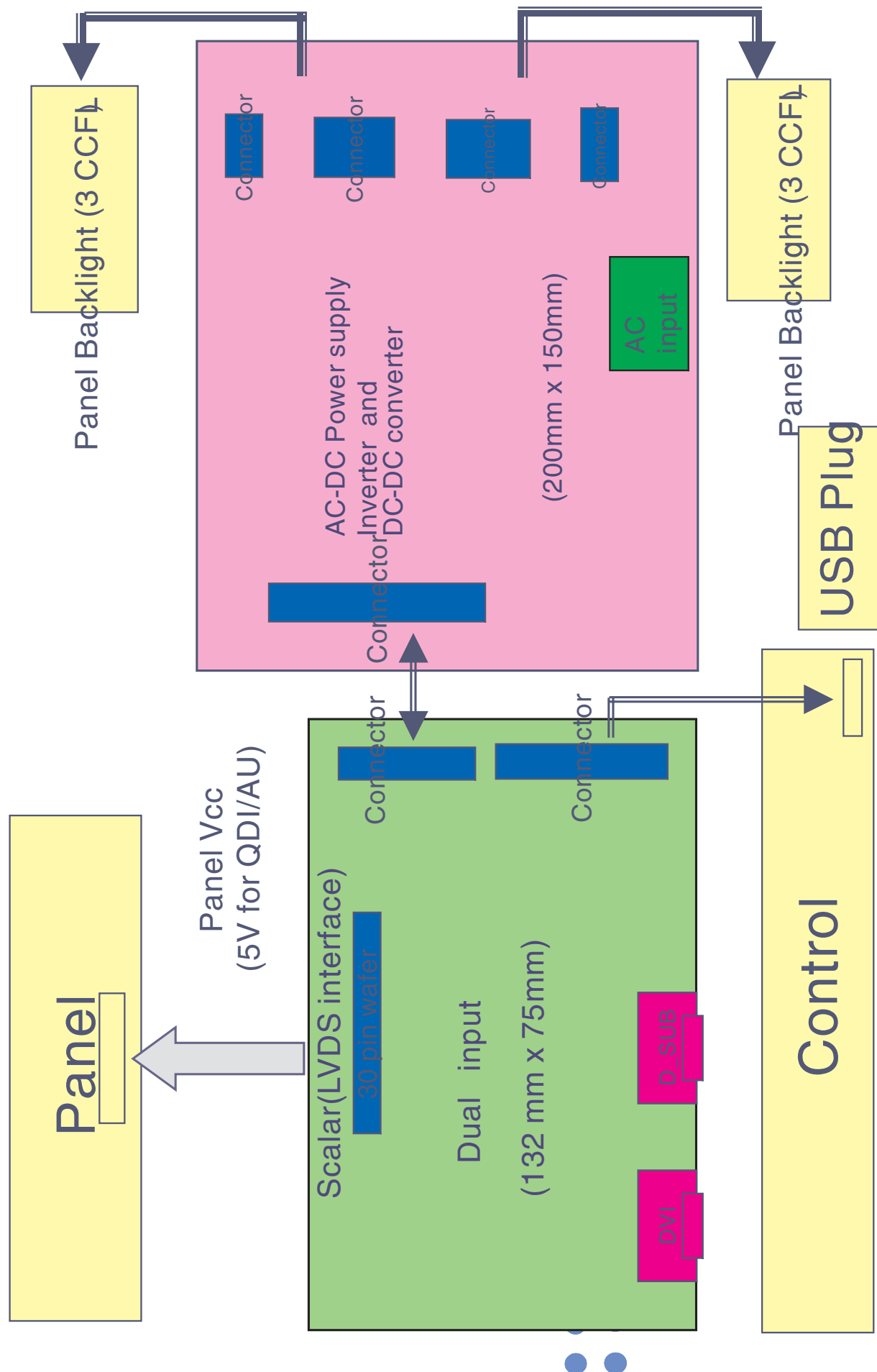

CONTENTS

SCHEMATIC Name	SHEET
01. Contents	1
02. DSUB/DVI	2
03. MCU	3
04. SCALER	4
05. IO	5

REVISION HISTORY

Date	Author	Ver	Comments
2005-09-21	Jerry Chen	A	PHILIPS UH7 200B7 SCALER SEHEMATIC FOR PROTOTYPE
2005-09-26	Jerry Chen	A	To add R419 100R at Scaler IC 68563HF pin 45
2005-09-26	Jerry Chen	A	To add C424 100N at IC 68563HF DPLL_VDD
2006-01-13	Kurtz Ko	1	Modify D-Sub Input circuits for phase improvement

Approval	Position	Signature	Date

SCALER BOARD			
Title			
200WB7EB/27			
Size	Document Number	Rev	
A	3138 158 65841	<RevCode>	
Date:	Wednesday, January 18, 2006	Sheet	1 of 5

Scaler Diagram-2

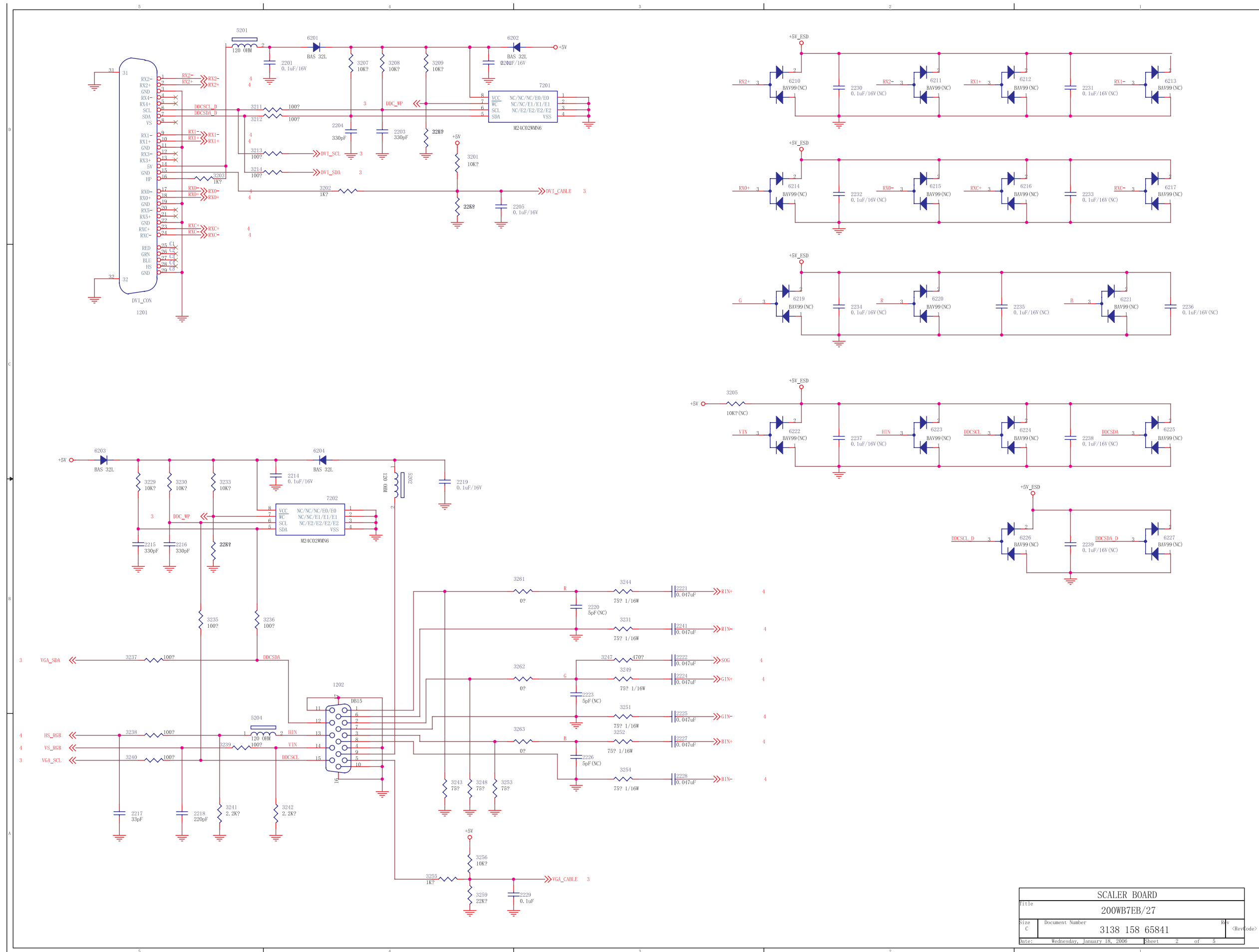

SCALER BOARD	
Title	200WB7EB/27
Size	Document Number 3138 158 65841
Date:	Wednesday, January 18, 2006 Sheet 2 of 5

Scaler Diagram-3

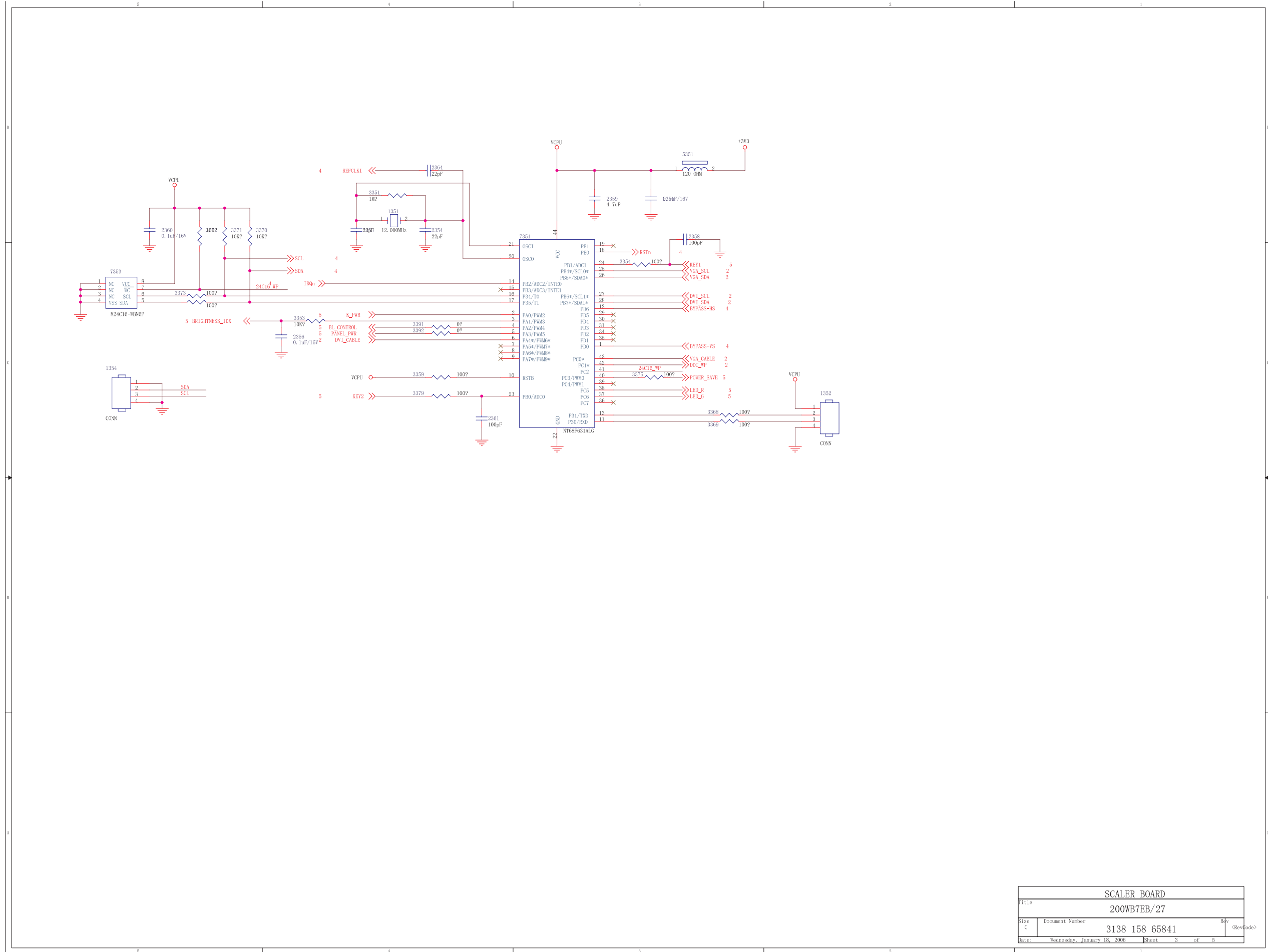

Title		SCALER BOARD	
Document Number		200WB7EB/27	
Size	C	Document Number	3138 158 65841
Date:	Wednesday, January 18, 2006	Sheet	3 of 5

Scaler Diagram-4

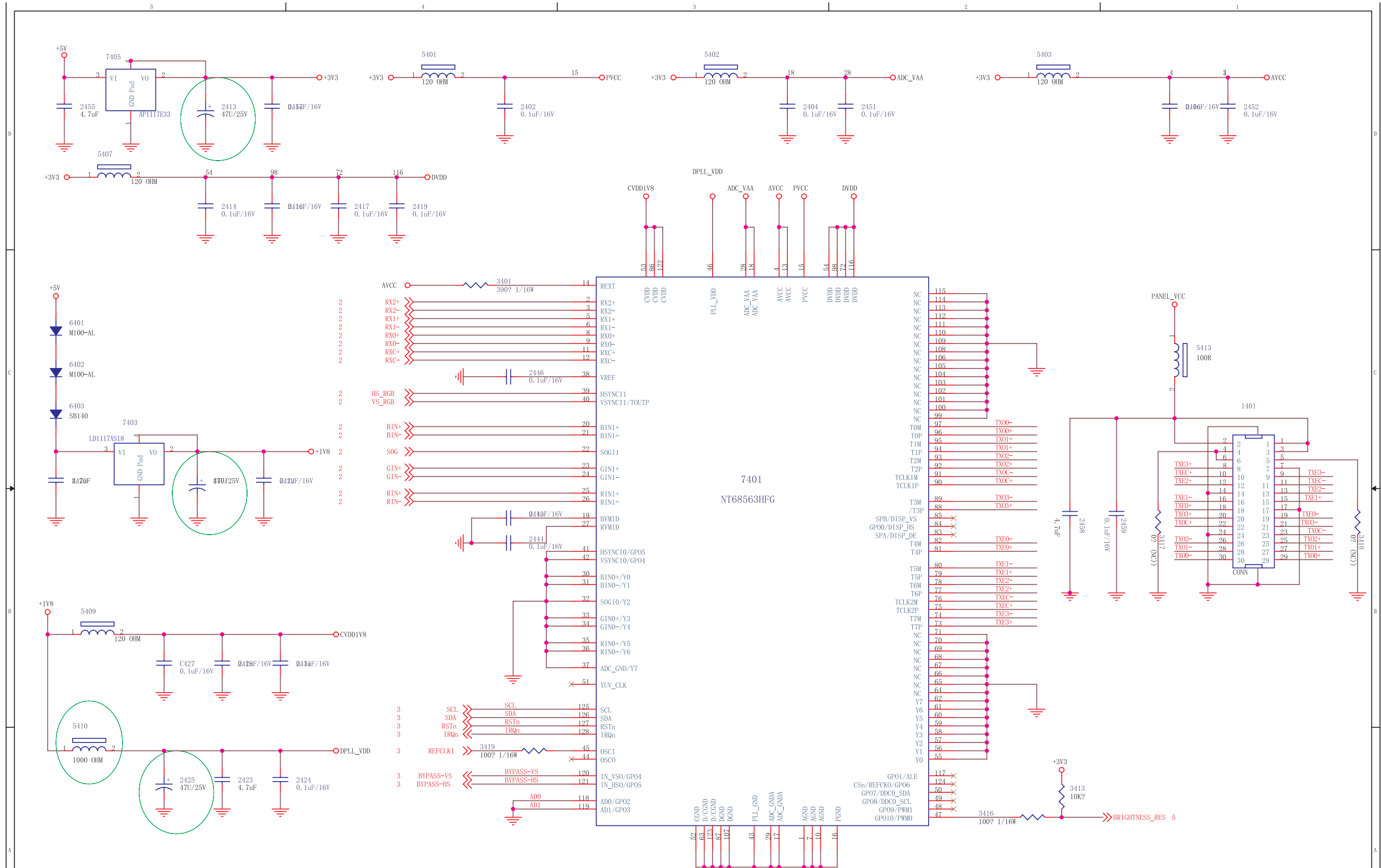

Title		SCALER BOARD	
Size		200WB7EB/27	
Document Number	3138 158 65841	Rev	<RevCode>
Date:	Wednesday, January 18, 2006	Sheet	4 of 5

Scaler Diagram-5

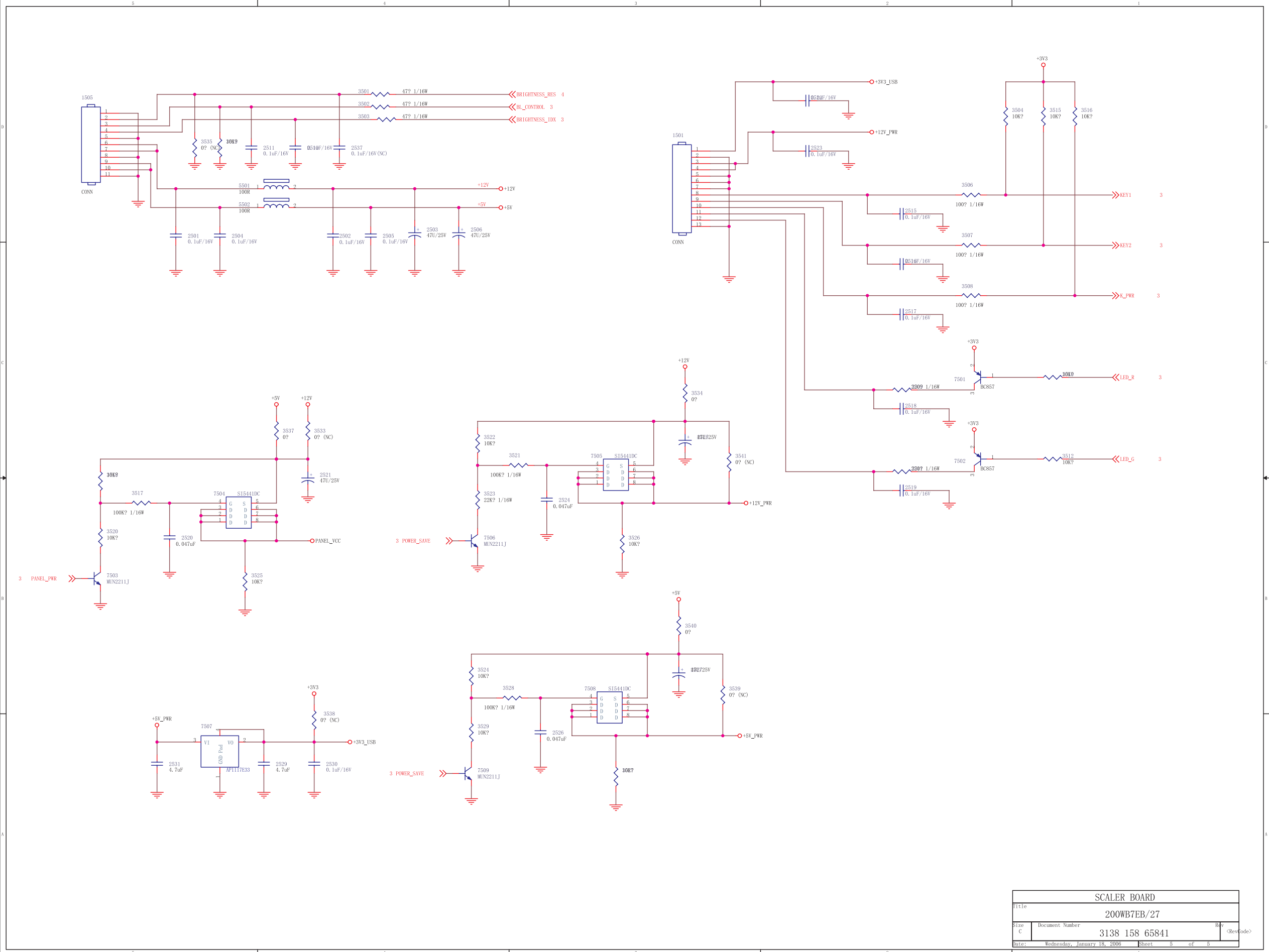

Title		SCALER BOARD	
Document Number		200WB7EB/27	
Size	C	3138 158 65841	<RevCode>
Date:	Wednesday, January 18, 2006	Sheet	5 of 5

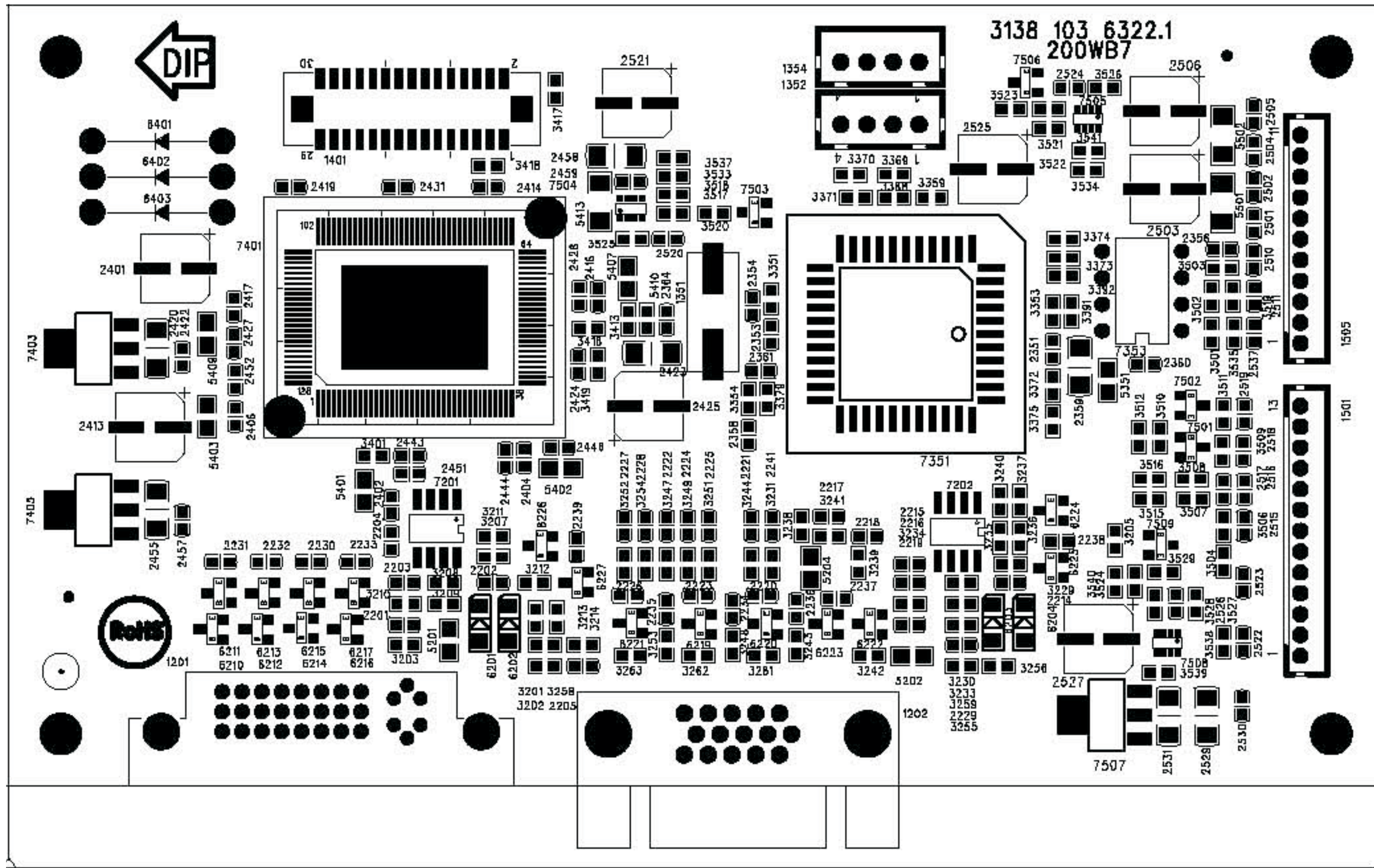

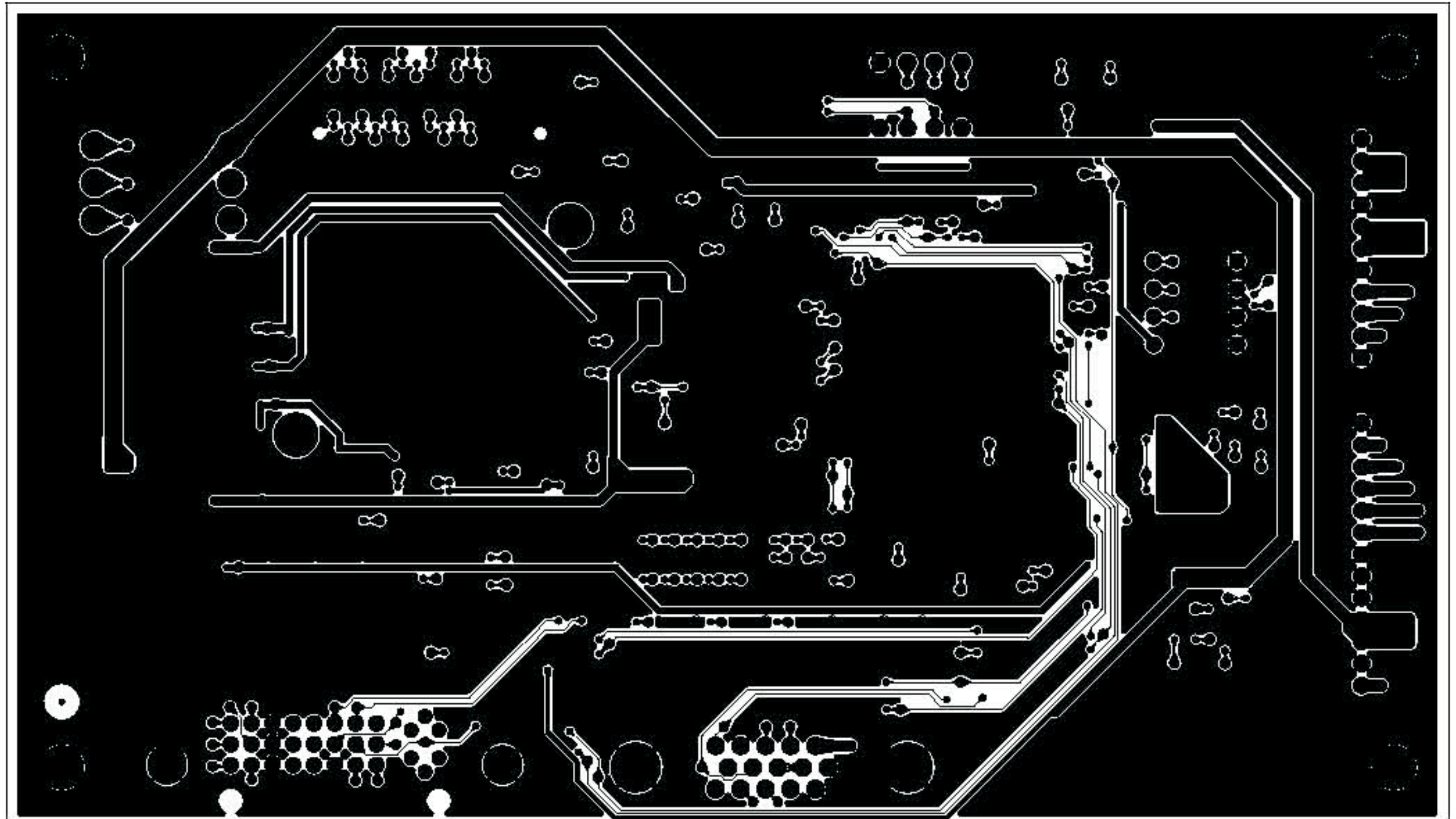

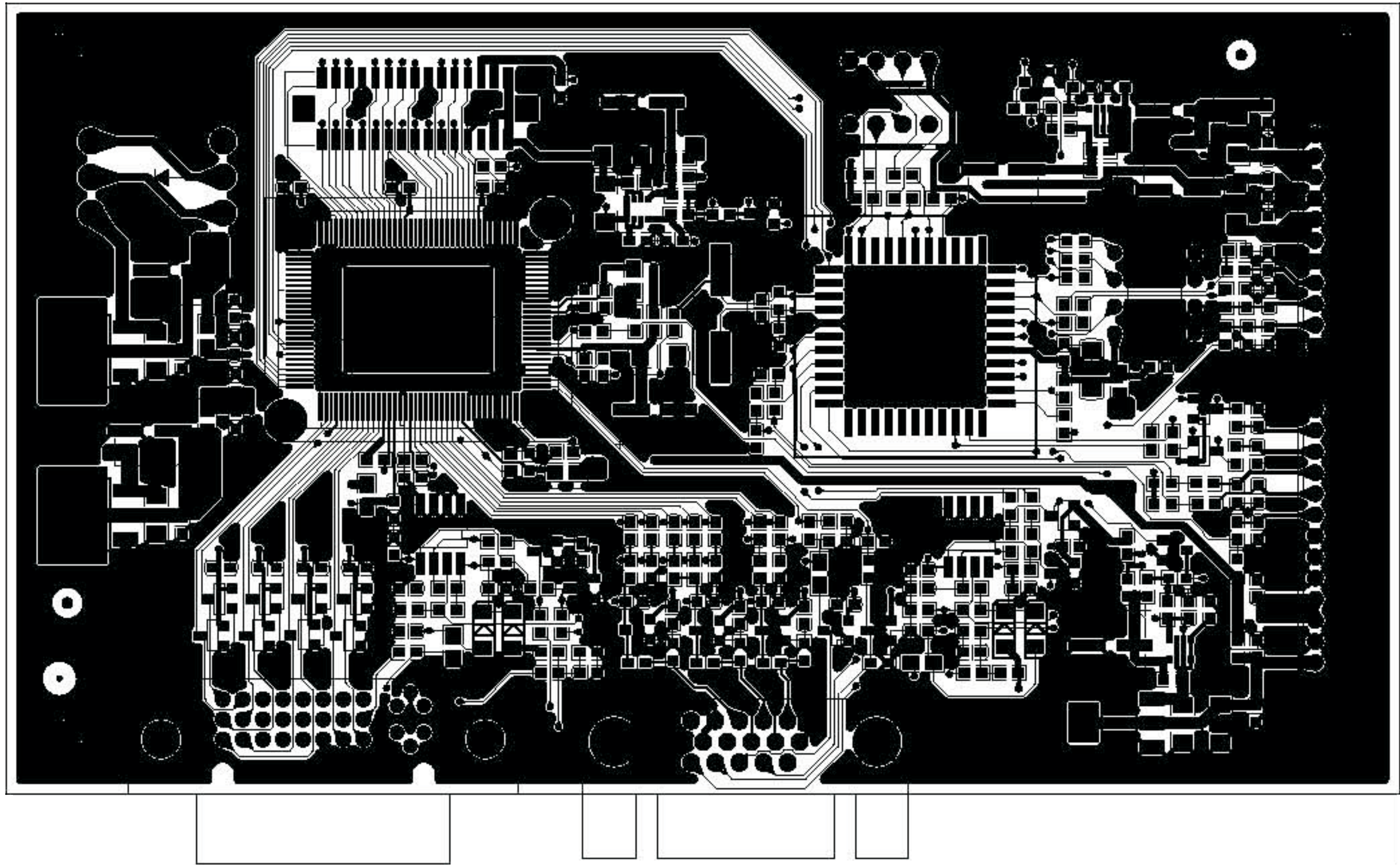

Control Diagram

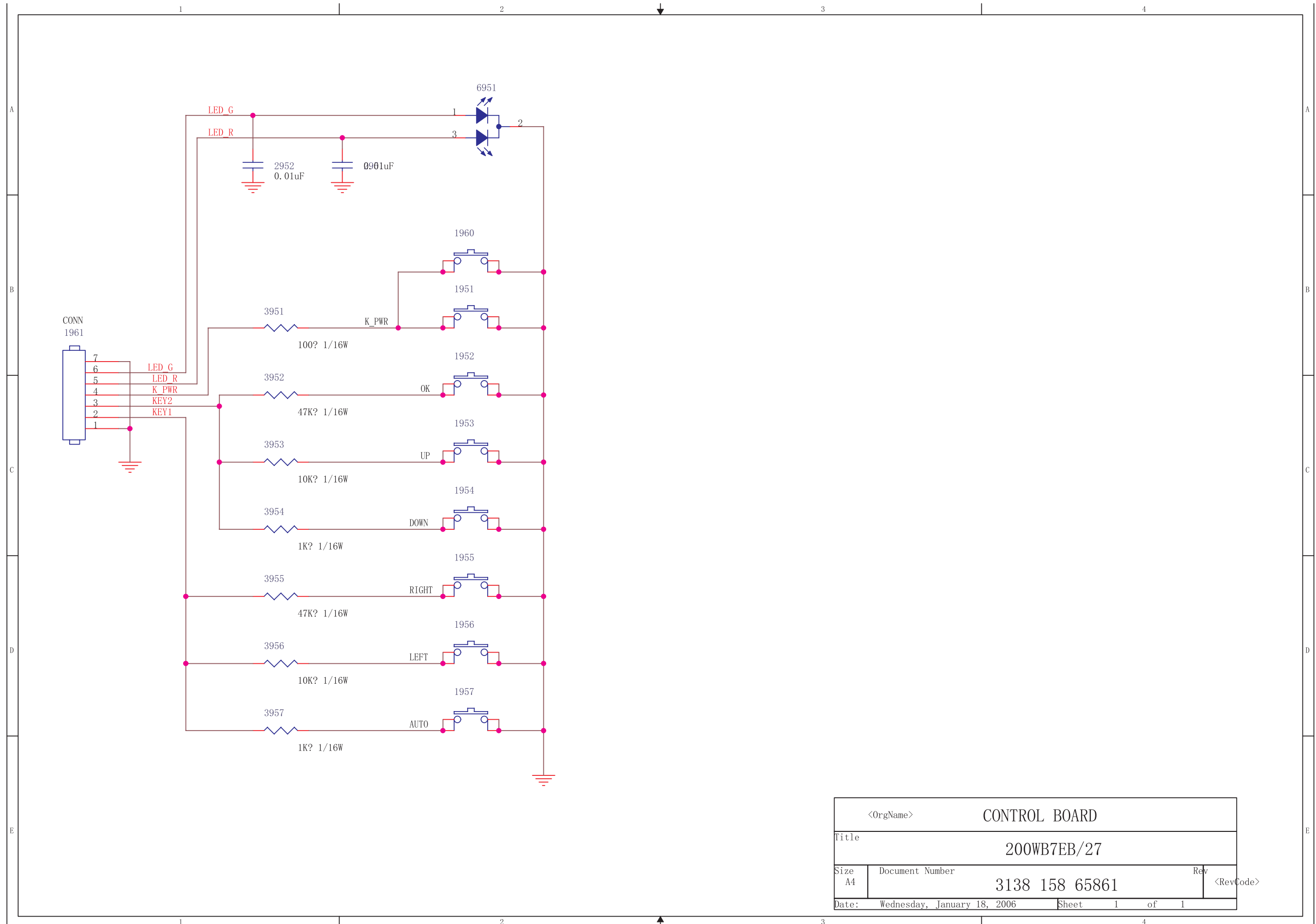

<OrgName>		CONTROL BOARD	
Title			
200WB7EB/27			
Size	Document Number	Rev	<RevCode>
A4	3138 158 65861		
Date:	Wednesday, January 18, 2006	Sheet	1 of 1

Control Board C.B.A.

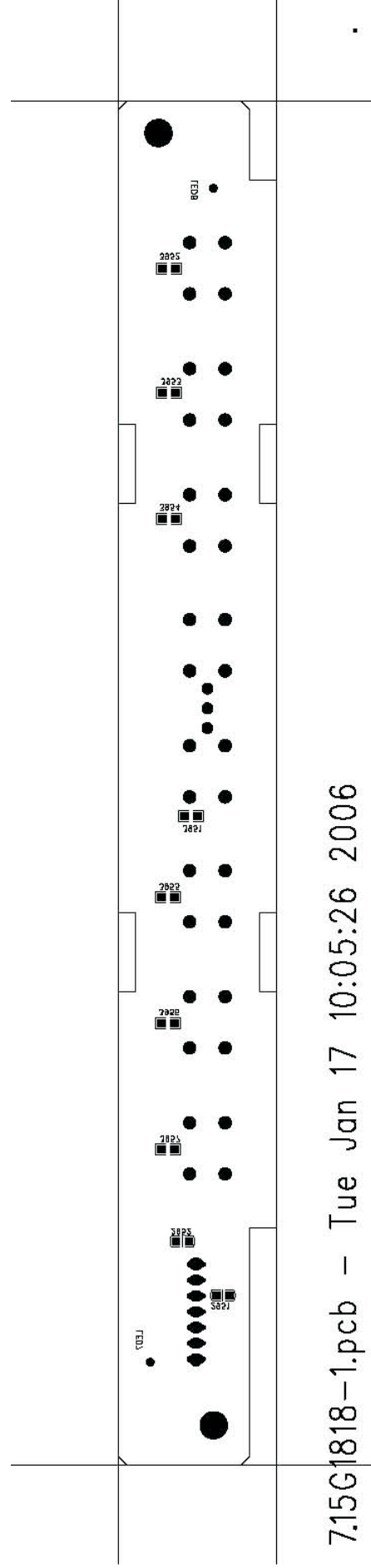
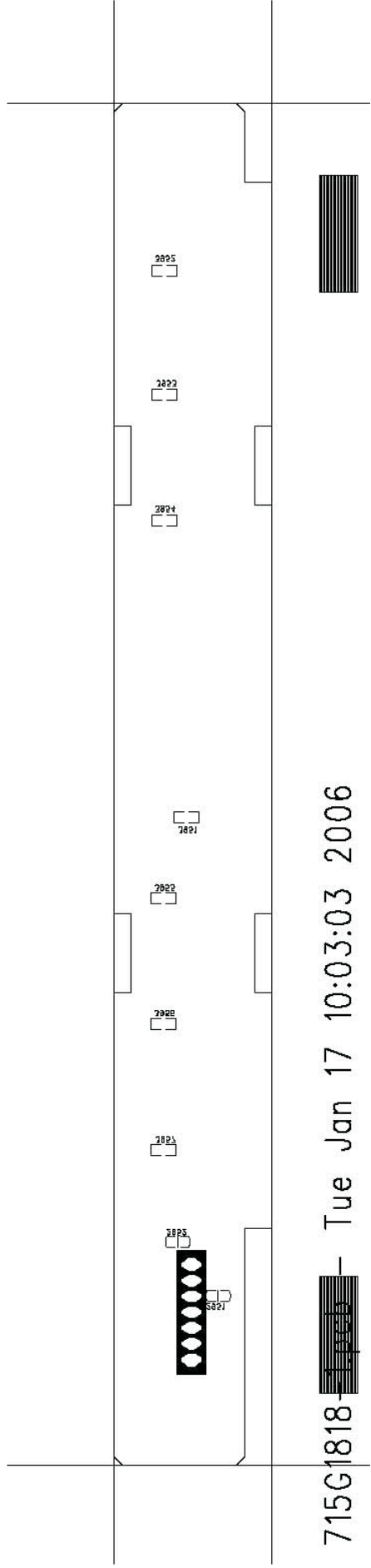
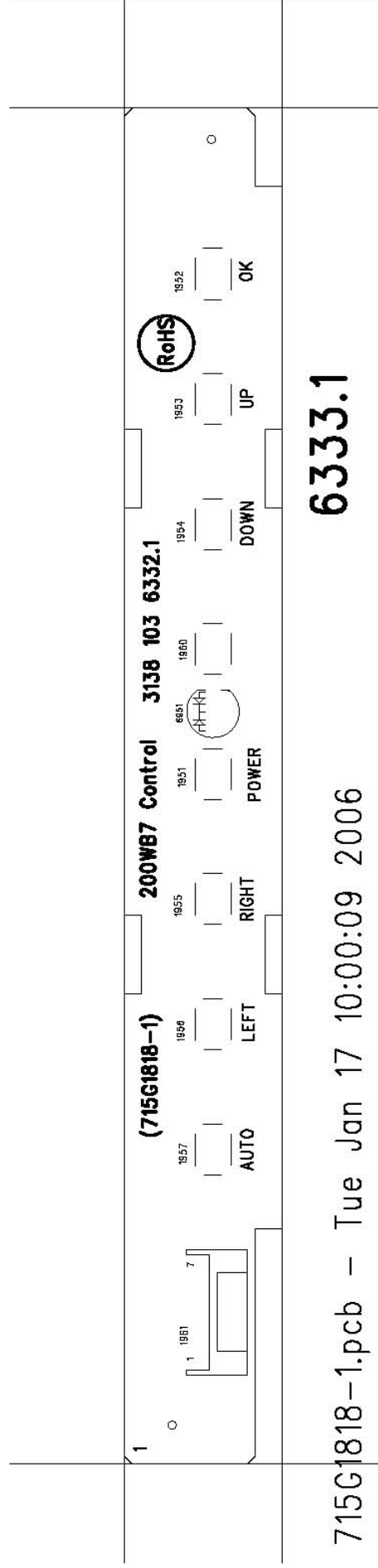

USB Diagram

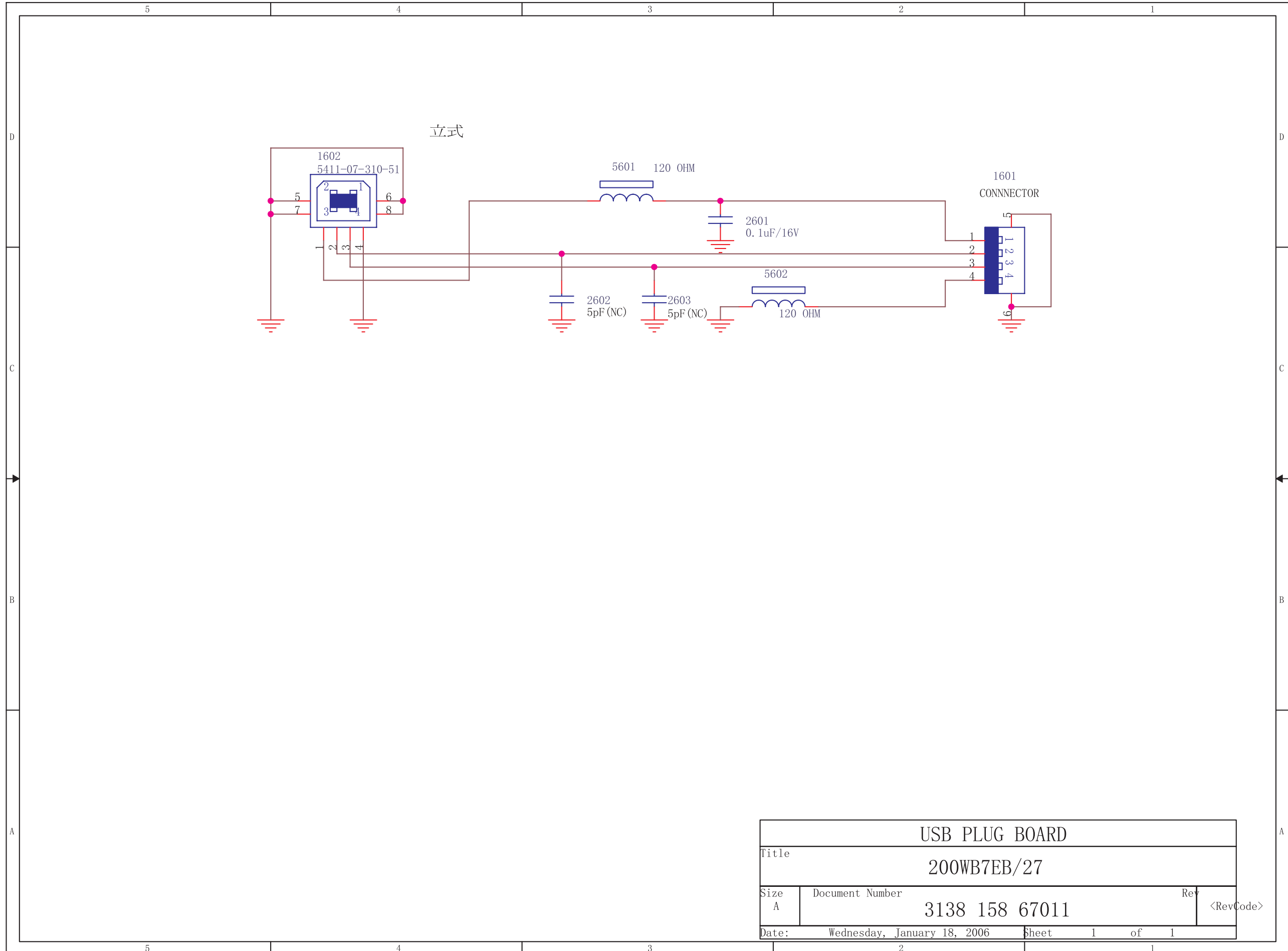

Title		USB PLUG BOARD	
Document Number		200WB7EB/27	
Size	Document Number	Rev	<RevCode>
A	3138 158 67011		
Date:	Wednesday, January 18, 2006	Sheet	1 of 1



715G1828-1.pcb - Tue Jan 17 09:28:43 2006 **6331.1**



715G1828-1.pcb - Tue Jan 17 09:32:38 2006

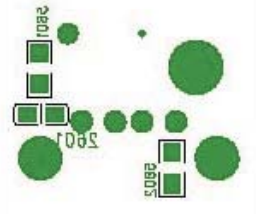

CH11

715G1828-1.pcb - Tue Jan 17 09:38:03 2006

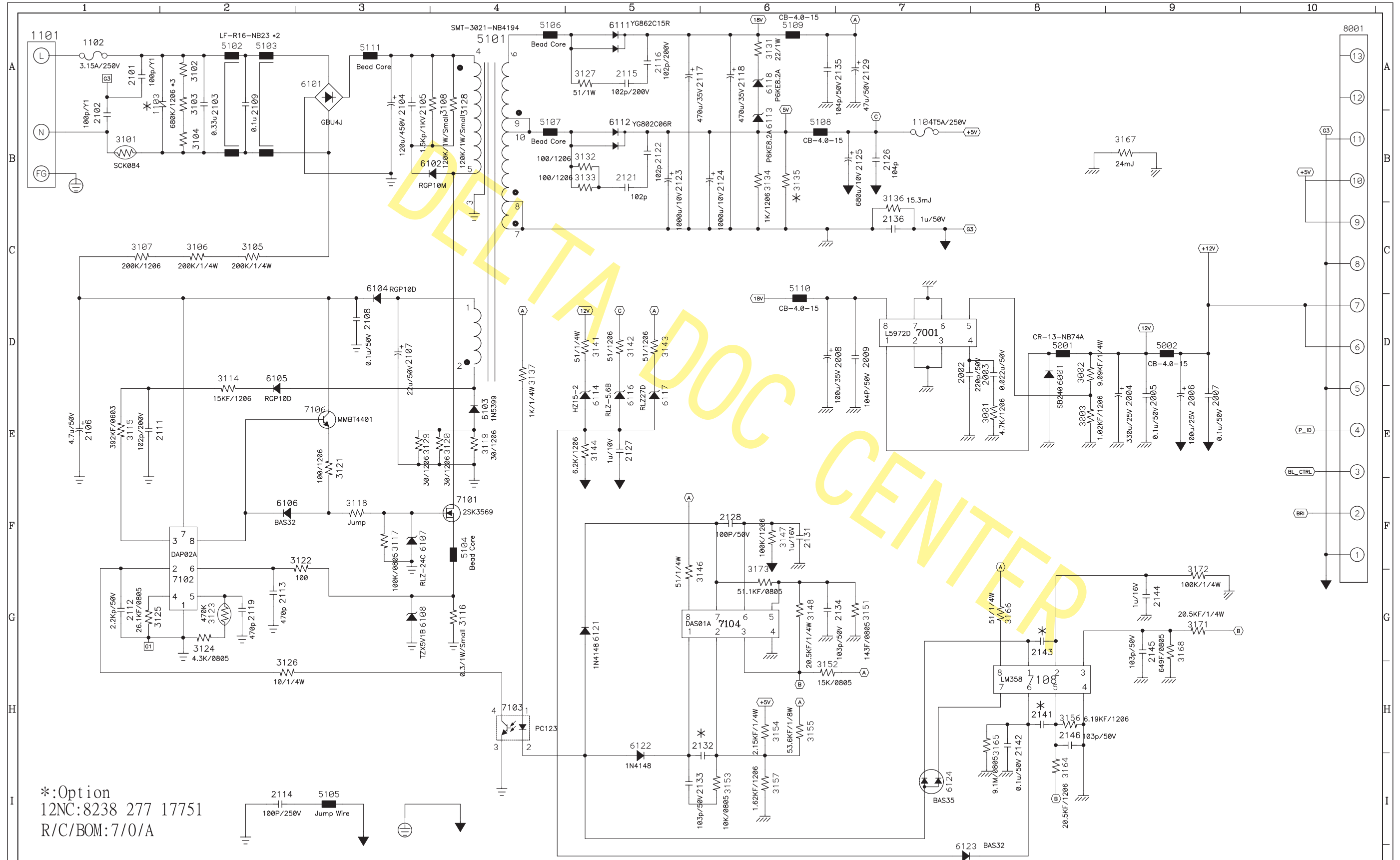

THESE DRAWINGS AND SPECIFICATIONS ARE THE PROPERTY OF DELTA ELECTRONICS, INC AND SHALL NOT BE REPRODUCED OR USED AS THE BASIS FOR THE MANUFACTURE OR SELL OF APPARATUSES OR DEVICES WITHOUT PERMISSON.

Date: 05/26/05 LY.REV:(R/C) 6/0 Drawn: RACHEL
 PWB:EADP-57BF A 2941013106 FILE NAME: SC-E57BF A
 DESCRIPTION:SCHEMATIC OF AC --> DC ADAPTOR

Checked 閻本孝 05/26/05

Approved 彭勇維 05/26/05

PART NO. EADP-57BF A

REV. S06 SHEET 01 OF 02

Power Diagram-2

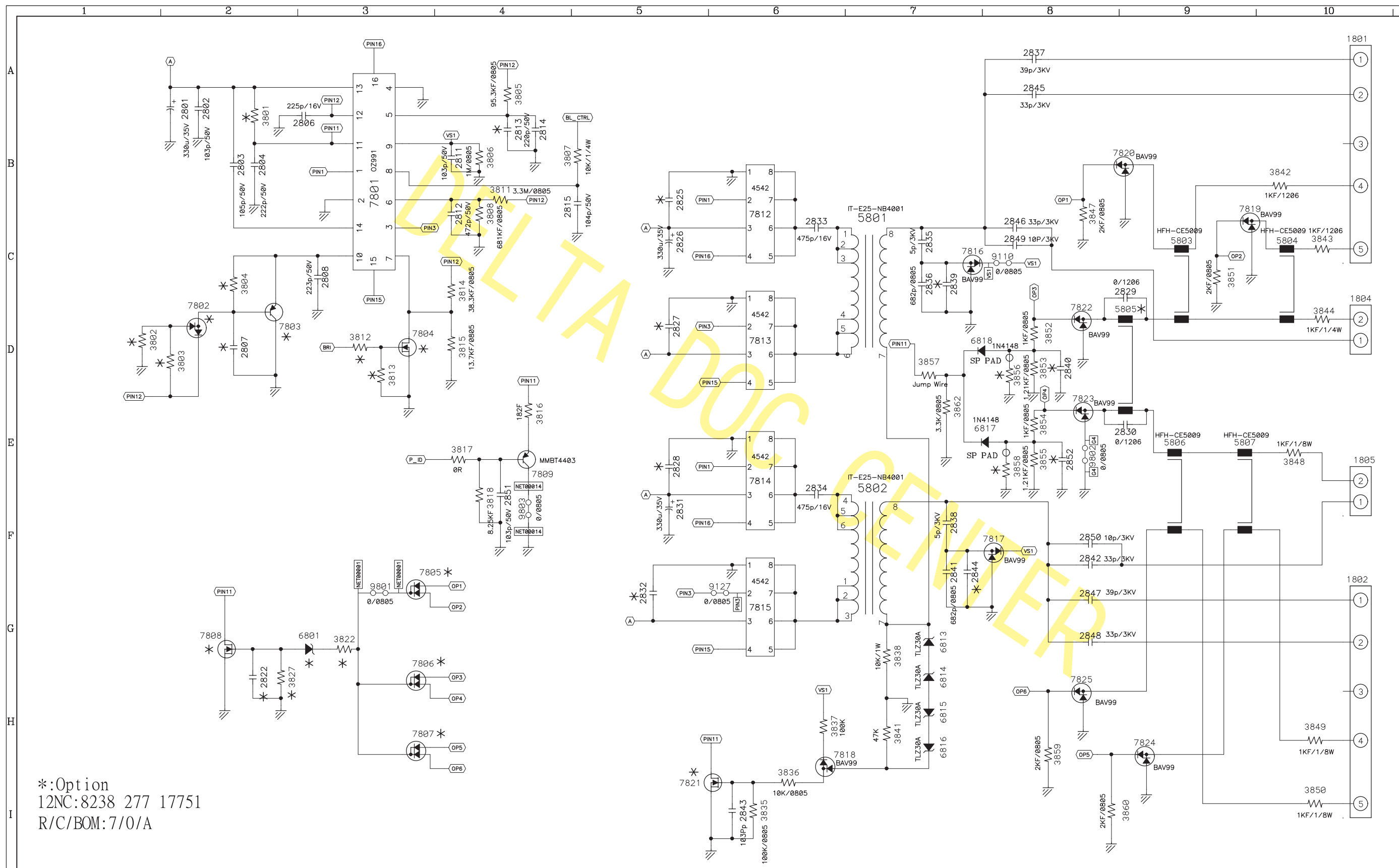

*:Option
 12NC:8238 277 17751
 R/C/BOM:7/0/A



THESE DRAWINGS AND SPECIFICATIONS ARE THE PROPERTY OF DELTA ELECTRONICS, INC AND SHALL NOT BE REPRODUCED OR USED AS THE BASIS FOR THE MANUFACTURE OR SELL OF APPARATUS OR DEVICES WITHOUT PERMISSION.

Date: 05/26/05 LY.REV:(R/C) 6/0 Drawn: RACHEL
 PWB:EADP-57BF A FILE NAME: SC-E57BF A
 2941013106
 DESCRIPTION:SCHEMATIC OF
 AC --> DC ADAPTOR

Checked	Approved	PART NO.	REV.	SHEET
閻本孝 05/26/05	彭勇維 05/26/05	EADP-57BF A	S06	02 OF 02

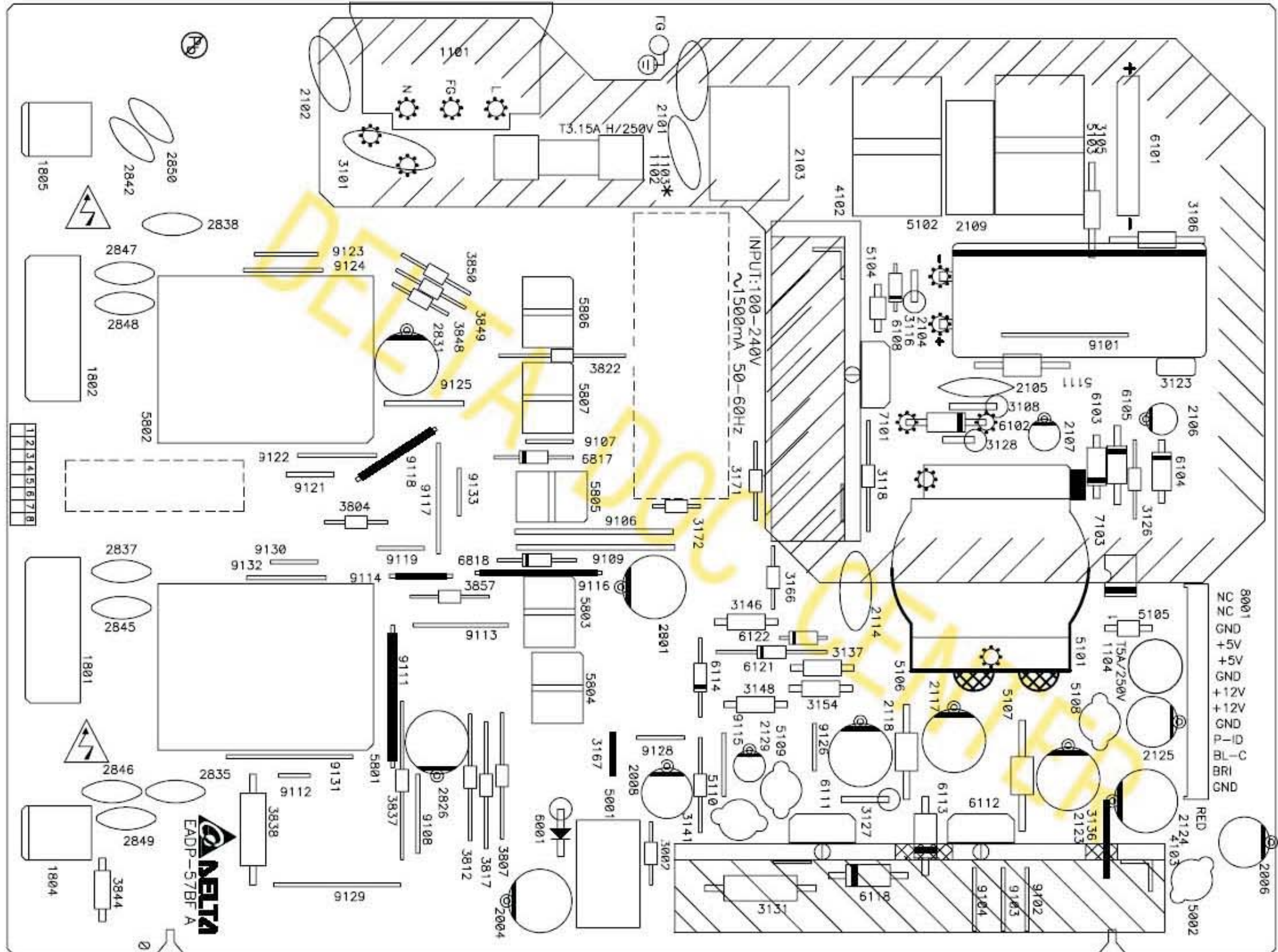

8001	NC
NC	NC
GND	
+5V	
+5V	
GND	
+12V	
+12V	
GND	
P-ID	
BL-C	
BRI	
GND	

 DELTA ELECTRONICS, INC.
 THESE DRAWINGS AND SPECIFICATIONS ARE THE PROPERTY OF DELTA ELECTRONICS, INC. AND SHALL NOT BE REPRODUCED OR USED AS THE BASIS FOR THE MANUFACTURE OR SALE OF APPARATUS OR DEVICES WITHOUT PERMISSION.
 DRAWING NO: PW-1:57BF A REV: 6
 USED ON: EADP-57BF A CODE: 0
 MADE BY: RACHEL DATE:05/26/05
 P/N: 2941013106
 COMPONENT SIDE SIZE: 4-1

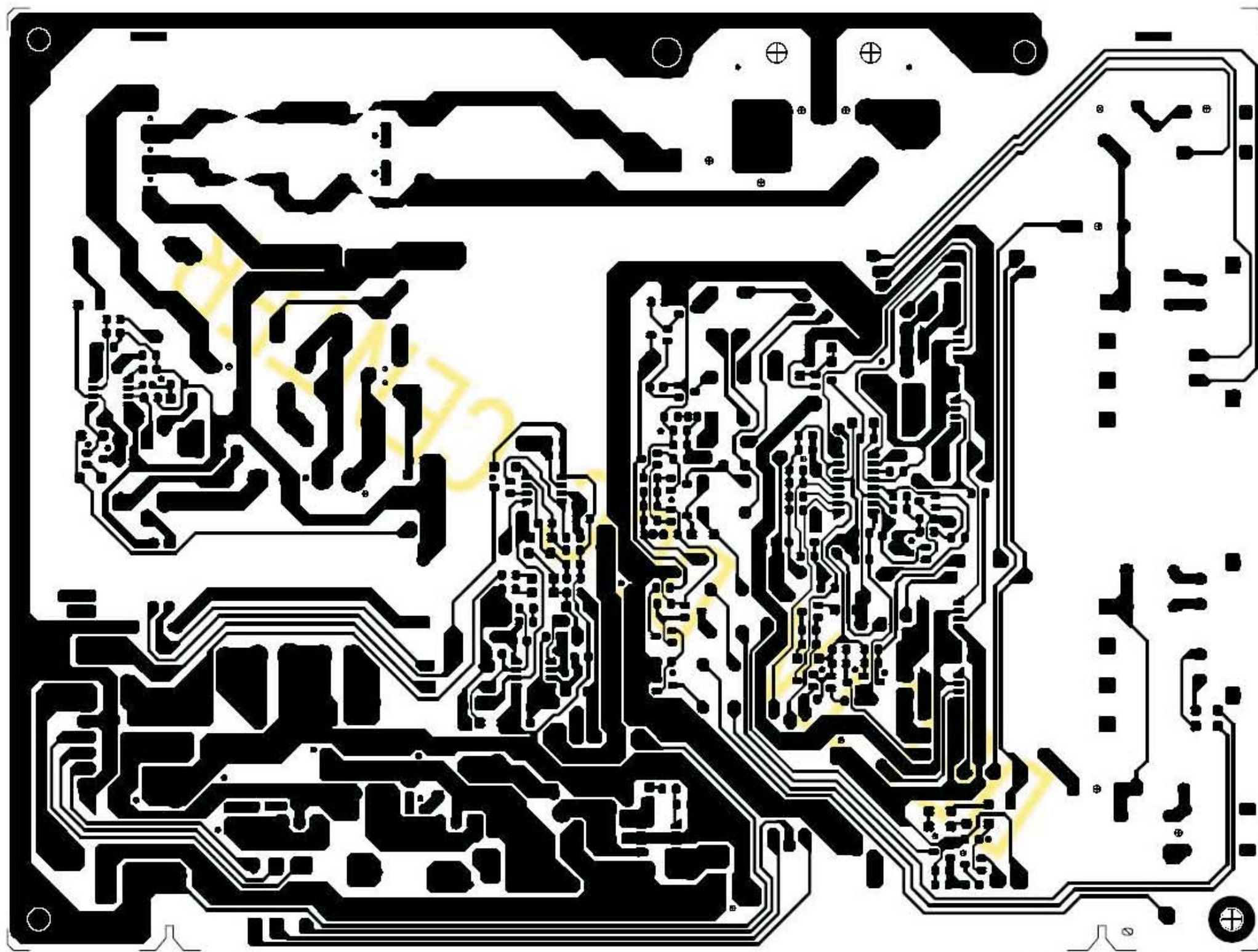

 DELTA DELTA ELECTRONICS, INC. THESE DRAWINGS AND SPECIFICATIONS ARE THE PROPERTY OF DELTA ELECTRONICS, INC. AND SHALL NOT BE REPRODUCED OR USED AS THE BASE FOR THE MANUFACTURE OR SELL OF APPARATUSES OR DEVICES WITHOUT PERMISSION	DRAWING NO:PT:57BF A	REV: 6
	USED ON: EADP-57BF A	CODE: 0
	MADE BY: RACHEL	DATE:05/26/'05
	P/N: 2941013106	SOLDER SIDE SIZE: 1=1

Exploded View

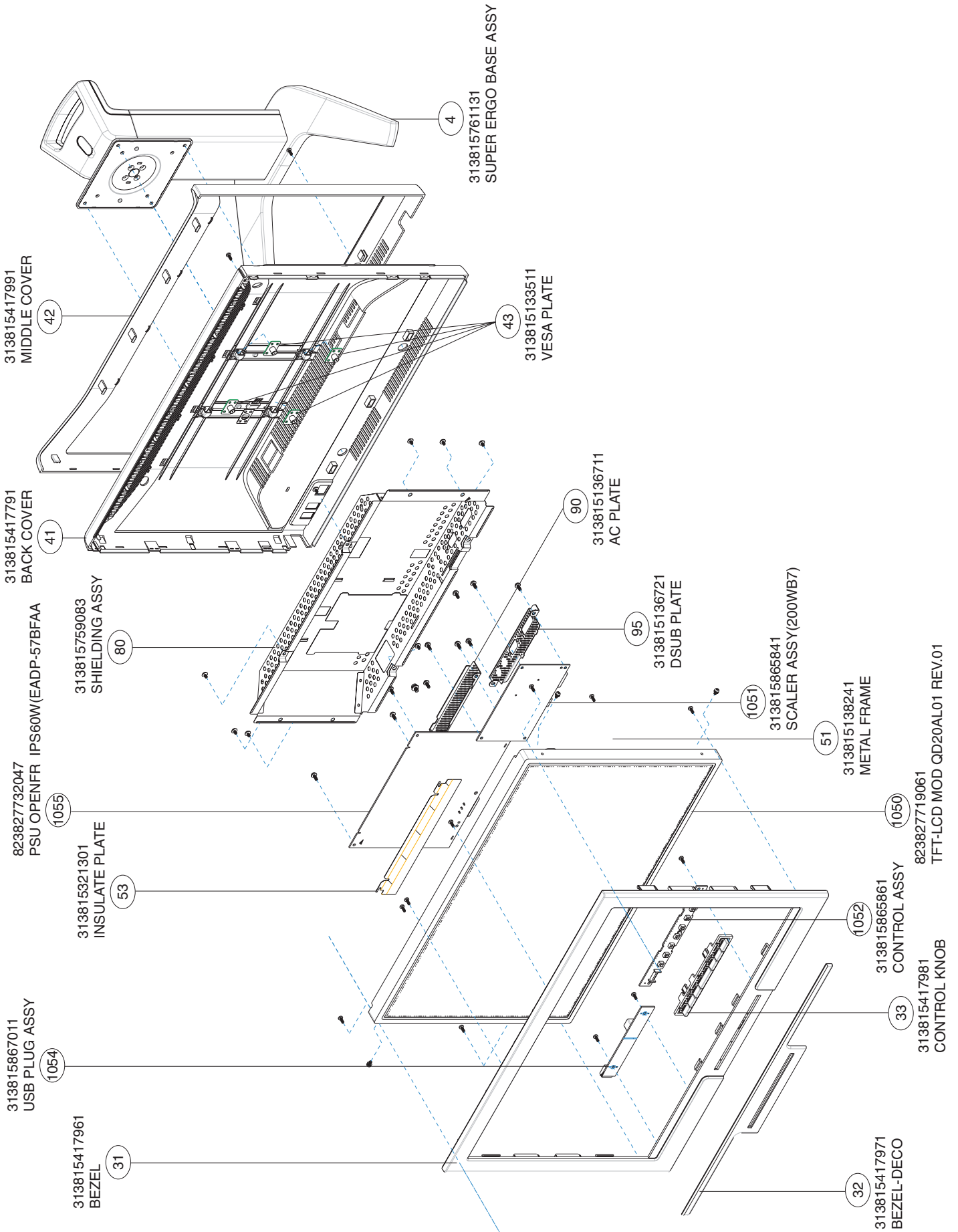



HUDSON7-200WB7
GENERAL PRODUCT
SPECIFICATION

Issued by: Joshua Lin / Argent Chan

- . ANALOG AND DIGITAL DUAL INPUT
- . AUTO PICTURE ADJUSTMENT
- . 15 FACTORY PRESET MODES AND 40 PRESET MODES WHICH CAN BE RECOVERED TO PRESET MODES, 25 USER MODES
- . USER FRIENDLY OSD DISPLAY FOR MODE IDENTIFICATION /ADJUSTMENT
- . MAX. RESOLUTION 1680 x 1050 NON-INTERLACED AT 76 HZ
- . 20.1" COLOR TFT LCD FLAT PANEL
- . SUPER ERGO BASE mini
- . FULL RANGE POWER SUPPLY 90 - 264 VAC
- . CE ENVIRONMENTAL POLICY
- . ANTI-GLARE TO REDUCE LIGHT REFLECTION
- . POWER MANAGEMENT CAPABILITY
- . SOG SUPPORT
- . TCO 03
- . USB PLUG SUPPORT
- . SMART CONTROL & SMART MANAGEMENT REQUIREMENT
- . WEEE REQUIREMENT
- . RoHS REQUIREMENT

All rights strictly reserved. Reproduction or issue to third parties in any form whatever is not permitted without written authority from the proprietors.



CLASS NO.		20.1 inch TFT WSXGA LCD Monitor		8639 000 16912	
		TYPE : 200WB7EB/27			
		BRAND : PHILIPS			
2006-03-03					
NAME	Kurtz Ko	SUPERS.	12	590	— 1
TY	CHECK	DATE	2006-03-03	10	A4
Property of PHILIPS ELECTRONICS INDUSTRIES (TAIWAN) LTD.-B.E.					



PHILIPS



All rights strictly reserved. Reproduction or issue to third parties in any form whatever is not permitted without written authority from the proprietors.

CONTENTS

1. FOREWORD
2. PRODUCT PROFILE
 - 2.1 LCD
 - 2.2 Scanning frequencies
 - 2.3 Ambient temperature : 0 °C - 35 °C
3. Electrical characteristics
 - 3.1 Interface signals
 - 3.2 Interface
 - 3.3 Timing requirement
 - 3.4 Horizontal scanning
 - 3.5 Vertical scanning
 - 3.6 Power input connection
 - 3.7 Power management
 - 3.8 Display identification
 - 3.9 Display identification
4. Visual characteristics
 - 4.1 Test conditions
 - 4.2 Brightness
 - 4.3 Image size
 - 4.4 Brightness uniformity
 - 4.5 Check Cross talk (S)
 - 4.6 White color adjustment
5. Mechanical characteristics
 - 5.1 Cosmetic - PHILIPS ID
 - 5.2 Mechanical data files - PROE FILES REQUIRED
 - 5.3 Location of Philips logo - PER PHILIPS MAKE-UP SHEET
 - 5.4 Gap between panel and front bezel < 1.2 mm
 - 5.5 Location of Control icons - PER PHILIPS MAKE-UP SHEET
 - 5.6 Color for resin/paint - PER PHILIPS MAKE-UP SHEET
 - 5.7 Resins
 - 5.8 If paint is used
 - 5.9 Plastic mold tooling
 - 5.10 Plastics flammability
 - 5.11 Texture/Glossing of housing
 - 5.12 Tilt and swivel base
 - 5.13 Label
 - 5.14 Product dimension / Weight
 - 5.15 Transportation
 - 5.16 Pallet/Container loading
6. Environmental characteristics
 - 6.1 Susceptibility of display to external environment
 - 6.2 Transportation tests
 - 6.3 Display disturbances from external environment
 - 6.4 Display disturbances to external environment
7. Reliability
 - 7.1 Mean Time Between Failures
8. Quality assurance requirements
 - 8.1 Acceptance test
9. Philips' Flat Panel Monitors Pixel Defect Policy
10. ARTWORKS
 - 10.1 Carton artwork
 - 10.2 Make up sheet
 - 10.3 EDFU cover page
 - 10.4 QSG
 - 10.5 Rating label

CLASS NO.		20.1 inch TFT WSXGA LCD Monitor		8639 000 16912	
		TYPE : 200WB7EB/27			
		BRAND : PHILIPS			
2006-03-03					
NAME	Kurtz Ko	SUPERS.	12	590	— 2
TY	CHECK	DATE	2006-03-03	Property of	PHILIPS ELECTRONICS INDUSTRIES (TAIWAN) LTD.-B.E.
				10	A4



All rights strictly reserved. Reproduction or issue to third parties in any form whatever is not permitted without written authority from the proprietors.

1. FOREWORD

This specification describes a 20.1" SXGA multi-scan color TFT LCD monitor with max. resolution up to 1680 x 1050 /75 Hz non-interlaced. All optical characteristics (including WHITE-D, Brightness, and so on) are determined according to panel specification after warming up approximate 30 minutes that brightness stability is optimal, and follow strictly after panel specification.

2. PRODUCT PROFILE

This display monitor unit is a color display monitor enclosed in PHILIPS global styling cabinet which has an integrated tilt and swivel base.

2.1 LCD

- 2.1.1 Type NR. : QD20AL01 v01 (QDI)
- Outside dimensions : 459.4(w)*296.4(h)*23.7(d) (Typ) mm
- Pitch (mm) : 0.258 mm x 0.258 mm
- Color pixel arrangement : RGB vertical stripes
- Display surface : low reflection, antiglare with hard coating
- Color depth : 16.2M colors (8 bits)
- Backlight : 6 CCFLs edge light system
- Active area(WxH) : 433.44x270.90 mm (20.1" diagonal)
- View angle (CR>10) : 70/70 (typ) for Horizontal & 65/60 (typ) for Vertical
- Contrast ratio : 600:1(Typ.) 400:1(Min.)
- White luminance : Original color 240 nits (Min), 300 nits (Typ.)
- Gate IC :
- Source IC :
- Response time : 8ms(Typ.),16ms(Max.)

2.2 Scanning frequencies

- Hor. : 30 - 98 KHz
- Ver. : 56 - 76 Hz
- Video dot rate : < 165 MHz
- Power input : 90-264 V AC, 50/60 ± 2 Hz
- Power consumption : < 48W maximum

Functions :

- (1) D-SUB analog R/G/B separate inputs, H/V sync separated, Composite (H+V) TTL level, SOG sync
- (2) DVI digital Panel Link TMDS input

2.3 Ambient temperature : 0 °C - 35 °C

3. Electrical characteristics

3.1 Interface signals

1). D-Sub Analog

- Input signal : Video, Hsync., Vsync
- Video : 0.7 Vp-p, input impedance, 75 ohm @DC
- Sync. : Separate sync TTL level , input impedance 2.2k ohm terminate
 - Hsync Positive/Negative
 - Vsync Positive/Negative
- Composite sync TTL level, input impedance 2.2k ohm terminate (Positive/Negative)
- Sync on green video 0.3 Vp-p Negative (Video 0.7 Vp-p Positive)

2). DVI-D Digital

Input signal: Single TMDS link (Three channels: RX0-/+, RX1-/+, RX2-/+))

3). USB Adaptor

- Input signal: Upstream input (V_{BUS}, D+, D-, GND) via USB-B receptacle.
- Output signal: Downstream output (V_{BUS}, D+, D-, GND) through USB-A receptacle

3.2 Interface

CLASS NO.		20.1 inch TFT WSXGA LCD Monitor		8639 000 16912	
		TYPE : 200WB7EB/27			
		BRAND : PHILIPS			
2006-03-03					
NAME Kurtz Ko	SUPERS.	12	590	3	10
TY	CHECK	DATE 2006-03-03	Property of PHILIPS ELECTRONICS INDUSTRIES (TAIWAN) LTD.-B.E.		



All rights strictly reserved. Reproduction or issue to third parties in any form, whatever is not permitted without written authority, from the proprietors.

3.2.1 D-Sub Cable

Length : 1.8 M +/- 50 mm
 Connector type : D-Sub male with DDC2B pin assignments.
 Blue connector thumb-operated jack screws

pin assignment :

PIN No.	SIGNAL
1	Red
2	Green/ SOG
3	Blue
4	Sense (GND)
5	Cable Detect (GND)
6	Red GND
7	Green GND
8	Blue GND
9	DDC +3.3V or +5V
10	Logic GND
11	Sense (GND)
12	Bi-directional data
13	H/H+V sync
14	V-sync
15	Data clock

3.2.2 DVI Cable

The input signals are applied to the display through DVI-D cable.
 Length. : 1.8 M +/- 50 mm
 Connector type. : DVI-D male with DDC-2B pin assignments
 White connector thumb-operated jackscrews

Pin Assignment:

Pin No.	Description
1	T.M.D.S. data2-
2	T.M.D.S. data2+
3	T.M.D.S. data2 shield
4	No Connect
5	No Connect
6	DDC clock
7	DDC data
8	No Connect
9	T.M.D.S. data1-
10	T.M.D.S. data1+
11	T.M.D.S. data1 shield
12	No Connect
13	No Connect
14	+5V Power
15	Ground (for +5V) □ Cable detect
16	Hot plug detect
17	T.M.D.S. data0-

CLASS NO.		20.1 inch TFT WSXGA LCD Monitor		8639 000 16912	
		TYPE : 200WB7EB/27			
		BRAND : PHILIPS			
2006-03-03					
NAME	Kurtz Ko	SUPERS.	12	590	— 4
TY	CHECK	DATE	2006-03-03	10	A4
Property of PHILIPS ELECTRONICS INDUSTRIES (TAIWAN) LTD.-B.E.					



18	T.M.D.S. data0+
19	T.M.D.S. data0 shield
20	No Connect
21	No Connect
22	T.M.D.S. clock shield
23	T.M.D.S. clock+
24	T.M.D.S. clock-

3.2.3 USB Cable (High Full Speed)
 Length. : 1.8 M +/- 50 mm (Max.)
 Connector type. : USB- B Plug (Input)
 USB- A Plug (Output)

Pin Assignment:

Pin No.	Description
1	VBUS
2	Data+
3	Data-
4	GND

3.2.4 Software control functions via OSD/control adjustable functions:
 OSD control bottom sequence.



Auto - left - right - power - down - (brightness) - up - ok

PC Analog only Signal Input Mode

Adjustable functions:

1 st LEVEL	2 nd LEVEL	3 rd LEVEL
MONITOR SETUP		
Exit		
Brightness & Contrast	Brightness Contrast	
Color	Original Color, 9300K,6500K, sRGB, User Define	
Position	Horizontal Vertical	
Input Selection	Analog(D-Sub), Digital (DVI-D)	

All rights strictly reserved. Reproduction or issue to third parties in any form whatever is not permitted without written authority from the proprietors.

CLASS NO.

20.1 inch TFT WSXGA LCD Monitor
 TYPE : 200WB7EB/27
 BRAND : PHILIPS

8639 000 16912

2006-03-03

NAME Kurtz Ko SUPERS. 12 590 — 5 10 A4

TY CHECK DATE 2006-03-03 Property of PHILIPS ELECTRONICS INDUSTRIES (TAIWAN) LTD.-B.E.

PHILIPS



More Settings	Language	/00,/05 : English, Spanish, French, German, Italian and Russian /27 : English, French, Spanish, Portuguese & S. Chinese /69,/75,/93,/96 : English, Spanish, French, German, Italian and S. Chinese
Reset	Phase/ Clock	Phase Clock
	Smart Bright	On, Off
	OSD Settings	Horizontal Vertical
	No Yes	
Serial No.:		
(Serial No.)		
Timing Mode		
Up/Down to Move, ok to Confirm		

Remark : " To move " at OSD window right-bottom.

" To adjust " at OSD window left-bottom.

Remark : Color Temperature factory default setting = 6500K for all regions.

Reset - No: Exit

Yes: Auto adjustment for displaying timing mode and recall factory preset

3.3 Timing requirement

3.3.1 Mode storing capacity

Factory preset modes : 15

Preset modes : 40

Note: 1. Screen displays perfect picture at 15 factory-preset modes.

2. Screen displays visible picture with OSD warning when input modes are the 40 preset modes

Factory preset modes (15 modes)

MODE NO.	1	2	3	4
RESOLUTION	640 x 350	720 x 400	640 x 480	640 x 480
Dot clock(MHz)	25.175	28.321	25.175	30.24
f h	31.469kHz	31.468kHz	31.5kHz	35 kHz
H-total (us)	31.778(800 dots)	31.78(900dots)	31.778(800 dots)	28.571 (864 dots)
H-sync width (us)	3.813(96 dots)	3.813(108dots)	3.813(96 dots)	2.116 (64 dots)
H-back porch (us)	1.907(48 dots)	1.907(54dots)	1.907(48 dots)	3.175(96 dots)
H-video width (us)	25.422(640 dots)	25.42(720dots)	25.422(640 dots)	21.164(640 dots)
H-front porch (us)	0.636(16 dots)	0.636(18dots)	0.636(16 dots)	2.116(64 dots)
f v	70Hz(70.09)	70Hz(70.085)	60Hz(59.940)	67Hz
V-total (ms)	14.27(449 lines)	14.27(449 lines)	16.683 (525 lines)	15 (525 lines)
V-sync width (ms)	0.064(2 lines)	0.064(2 lines)	0.064 (2 lines)	0.086(3 lines)
V-back porch (ms)	1.907(60 lines)	1.112(34 lines)	1.049 (33 lines)	1.114(39 lines)
V-video width (ms)	11.12(350 lines)	12.71(400 lines)	15.253 (480 lines)	13.714(480 lines)
V-front porch (ms)	1.175(37 lines)	0.381(13 lines)	0.317 (10 line)	0.086(3 line)
SYNC. H/V	+/-	-/+	- / -	- / -
POLARITY				
SEP . SYNC	Y	Y	Y	Y

All rights strictly reserved. Reproduction or issue to third parties in any form whatsoever is not permitted without written authority from the proprietors.

CLASS NO.

20.1 inch TFT WSXGA LCD Monitor
TYPE : 200WB7EB/27
BRAND : PHILIPS

8639 000 16912

2006-03-03

NAME Kurtz Ko	SUPERS.	12	590	—	6	10	A4
TY	CHECK	DATE 2006-03-03	Property of PHILIPS ELECTRONICS INDUSTRIES (TAIWAN) LTD.-B.E.				

PHILIPS



All rights strictly reserved. Reproduction or issue to third parties in any form whatever is not permitted without written authority from the proprietors.

MODE NO.	5	6	7	8
RESOLUTION	640 x 480	800 x 600	800 x 600	800 x 600
Dot clock(MHz)	31.500	36	40	49.498
f h	37.5kHz	35.156kHz	37.879kHz	46.875kHz
H-total (us)	26.667 (840 dots)	28.444(1024dots)	26.4 (1056 dots)	21.333 (1056 dots)
H-sync width (us)	2.032 (64 dots)	2.000 (72 dots)	3.2 (128 dots)	1.616 (80 dots)
H-back porch (us)	3.81 (120 dots)	3.556 (128 dots)	2.2 (88 dots)	3.232 (160 dots)
H-video width (us)	20.317 (640 dots)	22.222(800 dots)	20 (800 dots)	16.162 (800 dots)
H-front porch (us)	0.508 (16 dots)	0.666 (24 dots)	1 (40 dots)	0.323 (16 dots)
f v	75Hz	56.250Hz	60.317Hz	75Hz
V-total (ms)	13.333(500 lines)	17.778(625 lines)	16.579 (628 lines)	13.333 (625 lines)
V-sync width (ms)	0.08 (3 lines)	0.057 (2 lines)	0.106 (4 lines)	0.064 (3 lines)
V-back porch (ms)	0.427 (16 lines)	0.626 (22 lines)	0.607 (23 lines)	0.448 (21 lines)
V-video width (ms)	12.8 (480 lines)	17.066(600 lines)	15.84 (600lines)	12.8 (600 lines)
V-front porch (ms)	0.026 (1 lines)	0.029 (1 line)	0.026 (1 line)	0.021 (1 line)
SYNC. H/V	- / -	+ / +	+ / +	+ / +
POLARITY				
SEP . SYNC	Y	Y	Y	Y

MODE NO.	9	10	11	12
RESOLUTION	1024 x 768	1024 x 768	1152 x 870	1280 x 1024
Dot clock(MHz)	65	78.75	100	108
f h	48.363kHz	60.023kHz	68.7kHz	63.981kHz
H-total (us)	20.677(1344 dots)	16.66 (1312 dots)	14.56 (1456 dots)	15.63 (1688 dots)
H-sync width (us)	2.092(136 dots)	1.219 (96 dots)	1.28 (128 dots)	1.037 (112 dots)
H-back porch (us)	2.462(160 dots)	2.235 (176 dots)	1.44(144 dots)	2.296 (248 dots)
H-video width (us)	15.754(1024 dots)	13.003 (1024 dots)	11.52 (1152 dots)	11.852 (1280 dots)
H-front porch (us)	0.369(24 dots)	0.203 (16 dots)	0.32 (32 dots)	0.445 (48 dots)
f v	60.004Hz	75Hz (75.000)	75Hz	60.020Hz
V-total (ms)	16.666(806 lines)	13.328 (800 lines)	13.333(916 lines)	16.661 (1066 lines)
V-sync width (ms)	0.124(6 lines)	0.05(3 lines)	0.044 (3 lines)	0.047 (3 lines)
V-back porch (ms)	0.600(29 lines)	0.446 (28 lines)	0.568(39 lines)	0.594 (38 lines)
V-video width (ms)	15.880(768 lines)	12.80 (768 lines)	12.678(870 lines)	16.005 (1024 lines)
V-front porch (ms)	0.062(3 lines)	0.017 (1 line)	0.043 (4 line)	0.015 (1 line)
SYNC. H/V	- / -	+ / +	- / -	+ / +
POLARITY				
SEP . SYNC	Y	Y	Y	Y

MODE NO.	13	14	15
RESOLUTION	1280 x 1024	1600 x 1200	1680 x 1050
Dot clock(MHz)	135	162	146.250
f h (kHz)	79.976kHz	75	65.29
H-total (us)	12.504(1688 dots)	13.333(2160 dots)	15.316(2240 dots)
H-sync width (us)	1.067(144 dots)	1.185(192 dots)	1.203(176 dots)
H-back porch (us)	1.837(248 dots)	1.877(304 dots)	1.915(280 dots)
H-video width (us)	9.481(1280 dots)	9.877(1600 dots)	11.487(1680 dots)
H-front porch (us)	0.119(16 dots)	0.395(64 dots)	0.711(104 dots)
f v (Hz)	75.025Hz	60.000	59.954
V-total (ms)	13.329(1066 lines)	16.667(1250 lines)	16.679(1089 lines)
V-sync width (ms)	0.038(3 lines)	0.040(3 lines)	0.092(6 lines)
V-back porch (ms)	0.475(38 lines)	0.613(46 lines)	0.459(30 lines)
V-video width (ms)	12.804(1024 lines)	16.000(1200 lines)	16.082(1050 lines)
V-front porch (ms)	0.012 (1 line)	0.013(1 lines)	0.046(3 lines)
SYNC. H/V	+ / +	+ / +	+ / +
POLARITY			
SEP . SYNC	Y	Y	Y

CLASS NO.

20.1 inch TFT WSXGA LCD Monitor
 TYPE : 200WB7EB/27
 BRAND : PHILIPS

8639 000 16912

2006-03-03

NAME	Kurtz Ko	SUPERS.	12	590	—	7	10	A4
TY	CHECK	DATE	2006-03-03	Property of PHILIPS ELECTRONICS INDUSTRIES (TAIWAN) LTD.-B.E.				



All rights strictly reserved. Reproduction or issue to third parties in any form whatever is not permitted without written authority from the proprietors.

- 3.4 Horizontal scanning
Sync polarity : Positive or Negative
Scanning frequency : 30 - 98 K Hz
- 3.5 Vertical scanning
Sync polarity : Positive or Negative
Scanning frequency : 56 - 76 Hz
- 3.6 Power input connection
Power cord length : 1.8 M
Power cord type : 3 leads power cord with protective earth plug.
- 3.7 Power management
The monitor must comply with the Microsoft On Now specification, with two power management states, as defined by the VESA DPMS document. The monitor must appropriately display the DPMS state.

Mode	HSYNC	VSYNC	Video	Pwr-cons.	Indication	Rec. time
Power-On	On	On	active	< 48 W	Green LED	--
Off	Off	Off	blanked	< 2 W	Amber LED	< 3 s
DC Power Off			N/A	< 1 W	LED Off	

- 3.8 Display identification
In accordance with VESA Display Channel Standard Ver.1.0 and having DDC 2B capability
- 3.9 Display identification
In accordance with DVI requirement (DDWG digital Visual Interface revision 1.0) use DDC-2B, DDC/CI, and EDID 3.0 structure 2.0
- 4. Visual characteristics
- 4.1 Test conditions
Unless otherwise specified, this specification is defined under the following conditions.
 - (1) Input signal: As defined in 3.3, 1680 x 1050 non-interlaced mode (98K), signal sources must have 75 ohm output impedance.
 - (2) Luminance setting: controls to be set to 300 nits with full screen 100 % duty cycle white signal
 - (3) Warm up: more than 30 minutes after power on with signal supplied.
 - (4) Ambient light: 400 -- 600 lux.
 - (5) Ambient temperature: 20 ± 5 °C

4.2 Brightness
> 240 nits (at panel color temperature, at center of the screen, set contrast and brightness at maximum.)

4.3 Image size
Actual display size 376.32x301.056mm

4.4 Brightness uniformity
Set contrast at 100% and turn the brightness to get average above 240 nits at centre of the screen.
Apply the Fig 1, it should comply with the following formula:

$$\frac{B_{min}}{B_{max}} \times 100\% > 65\%$$

Where B_max =Maximum brightness
B_min = Minimum brightness

4.5 Check Cross talk (S)
Apply Pattern 2. Set contrast and brightness at 100 %.Measure YA. Then output Pattern 3 and measure YB.the cross talk value :

$$\frac{ABS(YA - YB)}{YA} \times 100\% < 1.5 \%$$

CLASS NO.		20.1 inch TFT WSXGA LCD Monitor		8639 000 16912	
		TYPE : 200WB7EB/27			
		BRAND : PHILIPS			
2006-03-03					
NAME	Kurtz Ko	SUPERS.	12	590	8
TY	CHECK	DATE	2006-03-03	10	A4
Property of PHILIPS ELECTRONICS INDUSTRIES (TAIWAN) LTD.-B.E.					



All rights strictly reserved. Reproduction or issue to third parties in any form whatever is not permitted without written authority from the proprietors.

- 4.6 White color adjustment
 There are three factory preset white color 9300K, 6500K, sRGB.
 Apply full gray64 pattern, with brightness in 100 % position and the contrast control at 50 % position. The 1931 CIE Chromaticity (color triangle) diagram (x,y) coordinate for the screen center should be:
 9300K CIE coordinates X = 0.283 ± 0.020
 Y = 0.297 ± 0.020
 6500K/ sRGB CIE coordinates X = 0.313 ± 0.020
 Y = 0.329 ± 0.020
 sRGB CIE coordinates X = 0.313 ± 0.020
 Y = 0.329 ± 0.020
5. Mechanical characteristics
- 5.1 Cosmetic - Philips ID
- 5.2 Mechanical data files - ProE files required
- 5.3 Location of Philips logo - Per Philips make-up sheet
- 5.4 Gap between panel and front bezel < 1.2 mm
- 5.5 Location of Control icons - Per Philips make-up sheet
 Front side: - tbc
 Rear : - tbc
- 5.6 Color for resin/paint - Per Philips make-up sheet
- 5.7 Resins
 RoHS required
 WEEE required.
 Resin type/selection refer to Project Book Section 7.2 Plastic material.
- 5.8 If paint is used
 RoHS required
 WEEE require
- 5.9 Plastic mold tooling
 Tooling to be designed to minimize cosmetic defects induced by molding process (sink, blush, weld lines, gate marks, ejector marks, etc.).
 Painting to cover up cosmetic defects due to molding is strongly discouraged.
- 5.10 Plastics flammability
 All Plastics to be Flame Retardant UL 94-V0 or Better (if monitor weighs less than 18kg; UL94-V0 is OK).
 All major plastic parts (bezel, back cover, base) need to be molded from same resin.
- 5.11 Texture/Glossing of housing
 The texture area and texture no should follow Philips make-up sheet.
 The exterior surfaces shall have a uniform texture.
 Philips must approve the mold texturing.
 Detail document for texture refer to UAN-D249.
 <= 20 gloss units
- 5.12 Tilt and swivel base
 Tilt angle : -5 ° max. forward , +25 ° min. backward.
 Swivel angle : +/- 45 °
 High Adjustment : 130mm
 Portrait Display : 90 ° CW
- 5.13 Label
 Regulatory label / Carton label should follow Philips requirement. Detail document refer to Philips Engineering Reference Book.
- 5.14 Product dimension / Weight

CLASS NO.		20.1 inch TFT WSXGA LCD Monitor		8639 000 16912	
		TYPE : 200WB7EB/27			
		BRAND : PHILIPS			
2006-03-03					
NAME	Kurtz Ko	SUPERS.	12	590	— 9 10 A4
TY	CHECK	DATE	2006-03-03	Property of PHILIPS ELECTRONICS INDUSTRIES (TAIWAN) LTD.-B.E.	



All rights strictly reserved. Reproduction or issue to third parties in any form whatever is not permitted without written authority from the proprietors.

Unit dimension (incl. pedestal) : 483(W) * 402 (H) * 235(D) mm
 Packed unit dimension (carton) : 579 (W) * 513 (H) * 267 (D) mm(for other regions)
 : 579 (W) * 513 (H) * 267 (D) mm(for China/India)
 Net weight : 8.7Kg (Including I/F cable 240 g)
 Gross weight : 10.6Kg(for other regions)
 : 10.6Kg (for China/India)

5.15 Transportation

Transportation standards refer to TYE-M0002.

5.15.1 Transportation packages

Packaging and wrapping shall be sufficient to protect the product against damage or loss during shipment from the supplier to the destination specified in the purchase order. All packaging materials are subject to test and evaluation

per TYE-M0002. The cushion material shall be constructed using EPS material.

5.15.2 Transportation Test_

The overall test refer to TYE-M0002. Vibration, drop test should be performed at ambient temperature(20 C to 23°C) and relative humidity (40% to 65%).

A. Transportation test specification for all regions except China/India

Package test

1. Random Vibration test
2. Drop test
3. Cold Drop test (for design reference)

Un-package test

1. Half sine shock test (non operation)

B. Transportation test specification for China/India

Package test

1. Random Vibration test
2. Drop test
3. Cold Drop test (for design reference)

Un-package test

1. Sine vibration (operating)
2. Half sine shock test (non operation)

5.16 Pallet / Container loading

Transportation standards refer to TYE-M0002.

Air shipment - refer sheet-560
 Sea container 20'(pallet/slip sheet) - refer sheet-560
 Sea container 40'(pallet/slip sheet) - refer sheet-560
 Sea container 40' High Cube (pallet/slip sheet) - refer sheet-560
 Truck shipment - refer sheet-560

- A. Air shipment
- B. Container loading for other regions
- C. Truck loading for other regions

6. Environmental characteristics

The following sections define the interference and susceptibility condition limits that might occur between external environment and the display device.

6.1 Susceptibility of display to external environment

Operating

- Temperature : 0 to 40 degree C

CLASS NO.	20.1 inch TFT WSXGA LCD Monitor				
	TYPE : 200WB7EB/27		8639 000 16912		
	BRAND : PHILIPS				
2006-03-03					
NAME Kurtz Ko	SUPERS.	12	590	— 10	10
TY	CHECK	DATE 2006-03-03	Property of PHILIPS ELECTRONICS INDUSTRIES (TAIWAN) LTD.-B.E.		



- Humidity : 80% max
 - Altitude : 0-3658m
 - Air pressure : 600-1100 mBAR
- Storage
- Temperature : -20 to 60 degree C
 - Humidity : 95% max
 - Altitude : 0-12192m
 - Air pressure : 300-1100 mBAR
- Note: recommend at 5 to 35°C, Humidity less than 60 %

- 6.2 Transportation tests
Refer to 5.15.2
- 6.3 Display disturbances from external environment
According to IEC 801-2 for ESD disturbances
- 6.4 Display disturbances to external environment
- 7. Reliability
 - 7.1 Mean Time Between Failures
System MTBF (Including the LCD panel and CCFL) : 50,000 hrs
- 8 Quality assurance requirements
 - 8.1 Acceptance test
According to MIL-STD-105D Control II level
AQL: 0.4% (major)
1.5 % (minor)
(Please also refer to annual quality agreement) Customer acceptance criteria: UAW0377/00
- 9 Philips Flat Panel Monitors Pixel Defect Policy
Philips Flat Panel Monitors Pixel Defect Policy

All rights strictly reserved. Reproduction or issue to third parties in any form whatever is not permitted without written authority from the proprietors.

BRIGHT DOT DEFECTS	ACCEPTABLE LEVEL		
MODEL	200WB7		
1 lit sub-pixel	3		
2 adjacent lit sub-pixels	1		
3 adjacent lit sub-pixels (one white pixel)	0		
Distance between two bright dot defects*	25mm or more		
Bright dot defects within 20 mm circle	0		
Total bright dot defects of all type	3		

BLACK DOT DEFECTS	ACCEPTABLE LEVEL		
MODEL	200WB7		
1 dark sub-pixel	5		
2 adjacent dark sub-pixels	2		
3 adjacent dark sub-pixels (one white pixel)	1		
Distance between two black dot defects*	15mm or more		
Total black dot defects of all type	5		

TOTAL DOT DEFECTS	ACCEPTABLE LEVEL		
MODEL	200WB7		
Total bright or black dot defects of all type	5		

*1 or 2 adjacent sub-pixel defects = 1 dot defect

CLASS NO.		20.1 inch TFT WSXGA LCD Monitor		8639 000 16912	
		TYPE : 200WB7EB/27			
		BRAND : PHILIPS			
2006-03-03					
NAME Kurtz Ko	SUPERS.	12	590	11	10
TY	CHECK	DATE 2006-03-03	Property of PHILIPS ELECTRONICS INDUSTRIES (TAIWAN) LTD.-B.E.		



- 10. ARTWORKS
- 10.1 Carton artwork
- 10.2 Make up sheet
- 10.3 EDFU cover page
- 10.4 QSG
- 10.5 Rating label

Fig 1: Brightness Uniformity

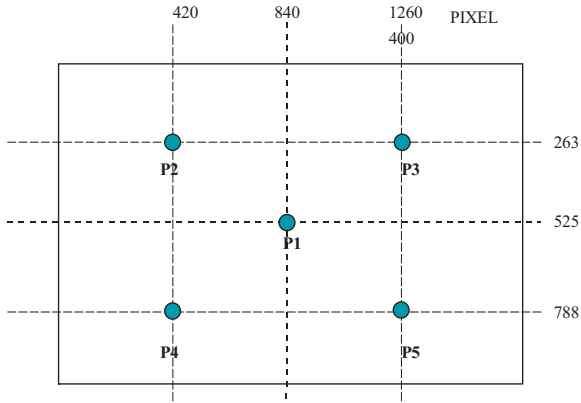

Fig 2: Cross talk pattern
Gray level 46 (64 Gray level)

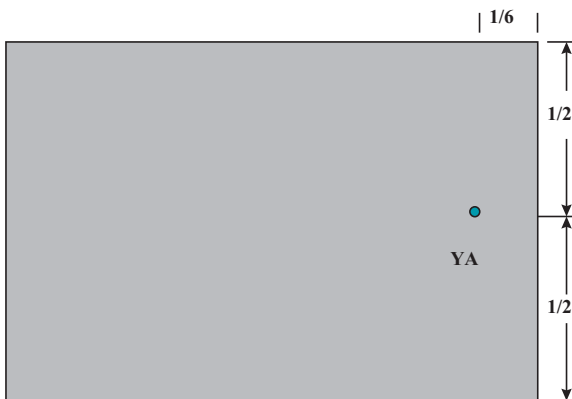
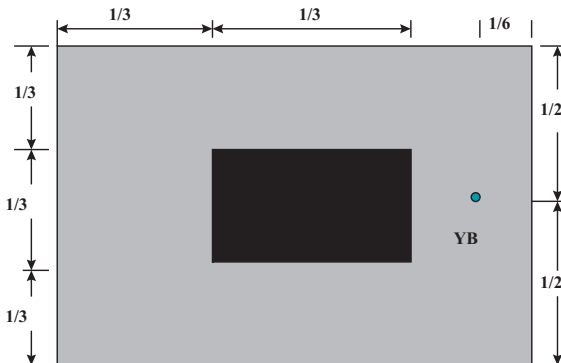

Fig 3: Cross talk Pattern
Center at Gray level 0 (Black)









All rights strictly reserved. Reproduction or issue to third parties in any form whatever is not permitted without written authority from the proprietors.

CLASS NO.		20.1 inch TFT WSXGA LCD Monitor TYPE : 200WB7EB/27 BRAND : PHILIPS	8639 000 16912		
2006-03-03					
NAME Kurtz Ko	SUPERS.	12	590 — 12	10	A4
TY	CHECK	DATE 2006-03-03	Property of PHILIPS ELECTRONICS INDUSTRIES (TAIWAN) LTD.-B.E.		

Spare Parts List

Model: 200WB7EB/27(QDI) 12NC: 8639 000 16912

Mechanical Parts			2202	223878615649	CER2 0603 X7R 16V 100N PM10 R	3211	232270260101	RST SM 0603 RC21	100R PM5 R
			2203	223886715331	CER1 0603 NP0 50V 330P PM5 R	3212	232270260101	RST SM 0603 RC21	100R PM5 R
			2204	223886715331	CER1 0603 NP0 50V 330P PM5 R	3213	232270260101	RST SM 0603 RC21	100R PM5 R
			2205	223878615649	CER2 0603 X7R 16V 100N PM10 R	3214	232270260101	RST SM 0603 RC21	100R PM5 R
			2214	223878615649	CER2 0603 X7R 16V 100N PM10 R	3229	232270260103	RST SM 0603 RC21	10K PM5 R
			2215	223886715331	CER1 0603 NP0 50V 330P PM5 R	3230	232270260103	RST SM 0603 RC21	10K PM5 R
			2216	223886715331	CER1 0603 NP0 50V 330P PM5 R	3231	232270260759	RST SM 0603 RC21	75R PM5 R
			2217	223886715339	CER1 0603 NP0 50V 33P PM5 R	3233	232270260103	RST SM 0603 RC21	10K PM5 R
			2218	223886715221	CER1 0603 NP0 50V 220P PM5 R	3234	232270260223	RST SM 0603 RC21	22K PM5 R
			2219	223878615649	CER2 0603 X7R 16V 100N PM10 R	3235	232270260101	RST SM 0603 RC21	100R PM5 R
			2221	223878615649	CER2 0603 X7R 16V 47N PM10 R	3236	232270260101	RST SM 0603 RC21	100R PM5 R
			2222	223878615649	CER2 0603 X7R 16V 47N PM10 R	3237	232270260101	RST SM 0603 RC21	100R PM5 R
			2224	223878615649	CER2 0603 X7R 16V 47N PM10 R	3238	232270260101	RST SM 0603 RC21	100R PM5 R
			2225	223878615649	CER2 0603 X7R 16V 47N PM10 R	3239	232270260101	RST SM 0603 RC21	100R PM5 R
			2227	223878615649	CER2 0603 X7R 16V 47N PM10 R	3240	232270260101	RST SM 0603 RC21	100R PM5 R
			2228	223878615649	CER2 0603 X7R 16V 47N PM10 R	3241	212211805661	RST SM 0603 RC0603	2K2 PM5 R
			2229	223878615649	CER2 0603 X7R 16V 100N PM10 R	3242	212211805661	RST SM 0603 RC0603	2K2 PM5 R
			2241	223878615649	CER2 0603 X7R 16V 47N PM10 R	3243	212211805964	RST SM 0603 RC0603	75R PM1 R
			2351	223878615649	CER2 0603 X7R 16V 100N PM10 R	3244	232270260759	RST SM 0603 RC21	75R PM5 R
			2353	223886715229	CER1 0603 NP0 50V 22P PM5 R	3247	232270260471	RST SM 0603 RC21	470R PM5 R
			2354	223886715229	CER1 0603 NP0 50V 22P PM5 R	3248	212211805964	RST SM 0603 RC0603	75R PM1 R
			2356	223878615649	CER2 0603 X7R 16V 100N PM10 R	3249	232270260759	RST SM 0603 RC21	75R PM5 R
			2358	223886715101	CER1 0603 NP0 50V 100P PM5 R	3251	232270260759	RST SM 0603 RC21	75R PM5 R
			2359	823827736009	CHIP 4.7UF 25V X7R 1206	3252	232270260759	RST SM 0603 RC21	75R PM5 R
			2360	223878615649	CER2 0603 X7R 16V 100N PM10 R	3253	212211805964	RST SM 0603 RC0603	75R PM1 R
			2361	223886715101	CER1 0603 NP0 50V 100P PM5 R	3254	232270260759	RST SM 0603 RC21	75R PM5 R
			2364	223886715229	CER1 0603 NP0 50V 22P PM5 R	3255	212211805656	RST SM 0603 RC0603	1K PM5 R
			2401	202203100205	ELCAP SM RVS 25V 47U PM20 R	3256	232270260103	RST SM 0603 RC21	10K PM5 R
			2402	223878615649	CER2 0603 X7R 16V 100N PM10 R	3258	232270260223	RST SM 0603 RC21	22K PM5 R
			2404	223878615649	CER2 0603 X7R 16V 100N PM10 R	3259	232270260223	RST SM 0603 RC21	22K PM5 R
			2406	223878615649	CER2 0603 X7R 16V 100N PM10 R	3261	232270296001	RST SM 0603 JUMP.	MAX 0R05 R
			2413	202203100205	ELCAP SM RVS 25V 47U PM20 R	3262	232270296001	RST SM 0603 JUMP.	MAX 0R05 R
			2414	223878615649	CER2 0603 X7R 16V 100N PM10 R	3263	232270296001	RST SM 0603 JUMP.	MAX 0R05 R
			2416	223878615649	CER2 0603 X7R 16V 100N PM10 R	3351	212211805689	RST SM 0603 RC0603	1M PM5 R
			2417	223878615649	CER2 0603 X7R 16V 100N PM10 R	3353	232270260103	RST SM 0603 RC21	10K PM5 R
			2419	223878615649	CER2 0603 X7R 16V 100N PM10 R	3354	232270260101	RST SM 0603 RC21	100R PM5 R
			2420	823827736009	CHIP 4.7UF 25V X7R 1206	3359	232270260101	RST SM 0603 RC21	100R PM5 R
			2422	223878615649	CER2 0603 X7R 16V 100N PM10 R	3368	232270260101	RST SM 0603 RC21	100R PM5 R
			2423	823827736009	CHIP 4.7UF 25V X7R 1206	3369	232270260101	RST SM 0603 RC21	100R PM5 R
			2424	223878615649	CER2 0603 X7R 16V 100N PM10 R	3370	232270260103	RST SM 0603 RC21	10K PM5 R
			2425	202203100205	ELCAP SM RVS 25V 47U PM20 R	3371	232270260103	RST SM 0603 RC21	10K PM5 R
			2427	223878615649	CER2 0603 X7R 16V 100N PM10 R	3372	232270260103	RST SM 0603 RC21	10K PM5 R
			2428	223878615649	CER2 0603 X7R 16V 100N PM10 R	3373	232270260101	RST SM 0603 RC21	100R PM5 R
			2431	223878615649	CER2 0603 X7R 16V 100N PM10 R	3374	232270260101	RST SM 0603 RC21	100R PM5 R
			2443	223878615649	CER2 0603 X7R 16V 100N PM10 R	3375	232270260101	RST SM 0603 RC21	100R PM5 R
			2444	223878615649	CER2 0603 X7R 16V 100N PM10 R	3379	232270260101	RST SM 0603 RC21	100R PM5 R
			2446	223878615649	CER2 0603 X7R 16V 100N PM10 R	3391	232270296001	RST SM 0603 JUMP.	MAX 0R05 R
			2451	223878615649	CER2 0603 X7R 16V 100N PM10 R	3392	232270296001	RST SM 0603 JUMP.	MAX 0R05 R
			2452	223878615649	CER2 0603 X7R 16V 100N PM10 R	3401	232270463901	RST SM 0603 RC22H	390R PM1 R
			2455	823827736009	CHIP 4.7UF 25V X7R 1206	3413	232270260103	RST SM 0603 RC21	10K PM5 R
			2457	223878615649	CER2 0603 X7R 16V 100N PM10 R	3416	232270260101	RST SM 0603 RC21	100R PM5 R
			2458	823827736009	CHIP 4.7UF 25V X7R 1206	3419	232270260101	RST SM 0603 RC21	100R PM5 R
			2459	223878615649	CER2 0603 X7R 16V 100N PM10 R	3501	232270260479	RST SM 0603 RC21	47R PM5 R
			2501	223878615649	CER2 0603 X7R 16V 100N PM10 R	3502	232270260479	RST SM 0603 RC21	47R PM5 R
			2502	223878615649	CER2 0603 X7R 16V 100N PM10 R	3503	232270260479	RST SM 0603 RC21	47R PM5 R
			2503	202203100205	ELCAP SM RVS 25V 47U PM20 R	3504	232270260103	RST SM 0603 RC21	10K PM5 R
			2504	223878615649	CER2 0603 X7R 16V 100N PM10 R	3506	232270260101	RST SM 0603 RC21	100R PM5 R
			2505	223878615649	CER2 0603 X7R 16V 100N PM10 R	3507	232270260101	RST SM 0603 RC21	100R PM5 R
			2506	202203100205	ELCAP SM RVS 25V 47U PM20 R	3508	232270260101	RST SM 0603 RC21	100R PM5 R
			2510	223878615649	CER2 0603 X7R 16V 100N PM10 R	3509	232270260221	RST SM 0603 RC21	220R PM5 R
			2511	223878615649	CER2 0603 X7R 16V 100N PM10 R	3510	232270260103	RST SM 0603 RC21	10K PM5 R
			2515	223878615649	CER2 0603 X7R 16V 100N PM10 R	3511	232270260221	RST SM 0603 RC21	220R PM5 R
			2516	223878615649	CER2 0603 X7R 16V 100N PM10 R	3512	232270260103	RST SM 0603 RC21	10K PM5 R
			2517	223878615649	CER2 0603 X7R 16V 100N PM10 R	3515	232270260103	RST SM 0603 RC21	10K PM5 R
			2518	223878615649	CER2 0603 X7R 16V 100N PM10 R	3516	232270260103	RST SM 0603 RC21	10K PM5 R
			2519	223878615649	CER2 0603 X7R 16V 100N PM10 R	3517	212211805683	RST SM 0603 RC0603	100K PM5 R
			2520	223878615649	CER2 0603 X7R 16V 47N PM10 R	3518	232270260103	RST SM 0603 RC21	10K PM5 R
			2521	202203100205	ELCAP SM RVS 25V 47U PM20 R	3519	232270260103	RST SM 0603 RC21	10K PM5 R
			2522	223878615649	CER2 0603 X7R 16V 100N PM10 R	3520	232270260103	RST SM 0603 RC21	10K PM5 R
			2523	223878615649	CER2 0603 X7R 16V 100N PM10 R	3521	212211805683	RST SM 0603 RC0603	100K PM5 R
			2524	223878615649	CER2 0603 X7R 16V 47N PM10 R	3522	232270260103	RST SM 0603 RC21	10K PM5 R
			2525	202203100205	ELCAP SM RVS 25V 47U PM20 R	3523	232270260223	RST SM 0603 RC21	22K PM5 R
			2526	223878615649	CER2 0603 X7R 16V 47N PM10 R	3524	232270260103	RST SM 0603 RC21	10K PM5 R
			2527	202203100205	ELCAP SM RVS 25V 47U PM20 R	3525	232270260103	RST SM 0603 RC21	10K PM5 R
			2529	823827736009	CHIP 4.7UF 25V X7R 1206	3526	232270260103	RST SM 0603 RC21	10K PM5 R
			2530	223878615649	CER2 0603 X7R 16V 100N PM10 R	3527	232270260103	RST SM 0603 RC21	10K PM5 R
			2531	823827736009	CHIP 4.7UF 25V X7R 1206	3528	212211805683	RST SM 0603 RC0603	100K PM5 R
			3201	232270260103	RST SM 0603 RC21	3529	232270260103	RST SM 0603 RC21	10K PM5 R
			3202	212211805656	RST SM 0603 RC0603	3534	232270296001	RST SM 0603 JUMP.	MAX 0R05 R
			3203	212211805656	RST SM 0603 RC0603	3537	232270296001	RST SM 0603 JUMP.	MAX 0R05 R
			3207	232270260103	RST SM 0603 RC21	3540	232270296001	RST SM 0603 JUMP.	MAX 0R05 R
			3208	232270260103	RST SM 0603 RC21	5201	242254944196	IND FXD 0805 EMI 100MHZ 120R R	
			3209	232270260103	RST SM 0603 RC21	5202	242254944196	IND FXD 0805 EMI 100MHZ 120R R	
			3210	232270260223	RST SM 0603 RC21	5204	242254944196	IND FXD 0805 EMI 100MHZ 120R R	

5351	242254944196	IND FXD 0805 EMI 100MHZ 120R R
5401	242254944196	IND FXD 0805 EMI 100MHZ 120R R
5402	242254944196	IND FXD 0805 EMI 100MHZ 120R R
5403	242254944196	IND FXD 0805 EMI 100MHZ 120R R
5407	242254944196	IND FXD 0805 EMI 100MHZ 120R R
5409	242254944196	IND FXD 0805 EMI 100MHZ 120R R
5410	242254900113	IND FXD 0603 EMI 100MHZ 1K R
5413	242254945579	IND FXD 1206 EMI 100MHZ 100R R
5501	242254945579	IND FXD 1206 EMI 100MHZ 100R R
5502	242254945579	IND FXD 1206 EMI 100MHZ 100R R
		
6201	933913910115	DIO SIG SM BAS32L (PHSE) R
6202	933913910115	DIO SIG SM BAS32L (PHSE) R
6203	933913910115	DIO SIG SM BAS32L (PHSE) R
6204	933913910115	DIO SIG SM BAS32L (PHSE) R
6401	932220675682	DIO REC M100AL-5301-E3 (VISH)B
6402	932220675682	DIO REC M100AL-5301-E3 (VISH)B
6403	933957760673	DIO REC SB140-E3 A (VISH) A
		
7201	932214526668	IC SM M24C02-WMN6 (ST00) R
7202	932214526668	IC SM M24C02-WMN6 (ST00) R
7351	313815867021	CPU IC ASSY-QDI
7351	932222343682	IC SM NT68F631ALG (NOVA) L
7353	313815867031	EEPROM IC ASSY-QDI
7353	932218650682	IC AT24C16A-10PU-2.7 (ATME) L
7401	823827737015	SCALER IC NT68563HFG
7403	932220099685	IC SM LD1117AS18 (ST00) R
7405	932216733668	IC SM LD1117S33 (ST00) R
7501	933769900215	TRA SIG SM BC857C (PHSE) R
7502	933769900215	TRA SIG SM BC857C (PHSE) R
7503	932217440685	TRA SIG SM KRC102S (KECO) R
7504	932216638668	FET POW SM SI5441DC-E3 (VISH)R
7505	932216638668	FET POW SM SI5441DC-E3 (VISH)R
7506	932217440685	TRA SIG SM KRC102S (KECO) R
7507	932216733668	IC SM LD1117S33 (ST00) R
7508	932216638668	FET POW SM SI5441DC-E3 (VISH)R
7509	932217440685	TRA SIG SM KRC102S (KECO) R
PCB Assy		
1052	313815865861	CONTROL ASSY
various		
1951	242212803007	SWI TACT 1P 1POS 12V V 5MM B
1952	242212803007	SWI TACT 1P 1POS 12V V 5MM B
1953	242212803007	SWI TACT 1P 1POS 12V V 5MM B
1954	242212803007	SWI TACT 1P 1POS 12V V 5MM B
1955	242212803007	SWI TACT 1P 1POS 12V V 5MM B
1956	242212803007	SWI TACT 1P 1POS 12V V 5MM B
1957	242212803007	SWI TACT 1P 1POS 12V V 5MM B
1960	242212803007	SWI TACT 1P 1POS 12V V 5MM B
1961	242202518897	CON H 7P M 2.00 63367 B
		
2951	223858619812	CER2 0603 Y5V 50V 100N P8020 R
2952	223858619812	CER2 0603 Y5V 50V 100N P8020 R
		
3951	232270260101	RST SM 0603 RC21 100R PM5 R
3952	232270260473	RST SM 0603 RC21 47K PM5 R
3953	232270260103	RST SM 0603 RC21 10K PM5 R
3954	212211805656	RST SM 0603 RC0603 1K PM5 R
3955	232270260473	RST SM 0603 RC21 47K PM5 R
3956	232270260103	RST SM 0603 RC21 10K PM5 R
3957	212211805656	RST SM 0603 RC0603 1K PM5 R
		
6951	932214603682	LED VS L-3WYGW (KIEL) B
PCB Assy		
1054	313815867011	USB PLUG ASSY
various		
1601	242202518875	SOC USB H 4P F 2.0 5401 Y
1602	242202518955	SOC USB V 4P F 2.5 5411 Y
		
2601	223858619812	CER2 0603 Y5V 50V 100N P8020 R
		
5601	242254944196	IND FXD 0805 EMI 100MHZ 120R R
5602	242254944196	IND FXD 0805 EMI 100MHZ 120R R

Recommended Parts List

TYPE:200WB7EB/27(QDI)

30	313815761101	BEZEL ASSY
31	313815417961	BEZEL
32	313815417971	BEZEL-DECO
33	313815417981	CONTROL KNOB
40	313815761111	BACK COVER ASSY
41	313815417791	BACK COVER
42	313815417991	MIDDLE COVER
43	313815133511	VESA PLATE
51	313815138241	METAL FRAME
53	313815321301	INSULATE PLATE
80	313815759083	SHIELDING ASSY
90	313815136711	AC PLATE
95	313815136721	DSUB PLATE
129	313810632613	PE BAG
340	313815136703	SHIELDING
341	313815421312	INSULATING PLATE
450	313815641831	CARTON
451	313815641841	CUSHION - TOP
452	313815641851	CUSHION - BUTTON
453	313815641821	P.E. BAG
508	313815641831	CARTON
508	313815641831	CARTON
1055	823827732047	PSU OPENFR IPS60W(EADP-57BFAA
1057	313815867201	FRAME+WIRE ASSY
7201	932214526668	IC SM M24C02-WMN6 (ST00) R
7202	932214526668	IC SM M24C02-WMN6 (ST00) R
7351	313815867021	CPU IC ASSY-QDI
7351	932222343682	IC SM NT68F631ALG (NOVA) L
7353	313815867031	EEPROM IC ASSY-QDI
7353	932218650682	IC AT24C16A-10PU-2.7 (ATME) L
7401	823827737015	SCALER IC NT68563HFG
7403	932220099685	IC SM LD1117AS18 (ST00) R
7405	932216733668	IC SM LD1117S33 (ST00) R
7501	933769900215	TRA SIG SM BC857C (PHSE) R
7502	933769900215	TRA SIG SM BC857C (PHSE) R
7503	932217440685	TRA SIG SM KRC102S (KEC0) R
7504	932216638668	FET POW SM SI5441DC-E3 (VISH)R
7505	932216638668	FET POW SM SI5441DC-E3 (VISH)R
7506	932217440685	TRA SIG SM KRC102S (KEC0) R
7507	932216733668	IC SM LD1117S33 (ST00) R
7508	932216638668	FET POW SM SI5441DC-E3 (VISH)R
7509	932217440685	TRA SIG SM KRC102S (KEC0) R

0. Warning

All ICs and many other semi-conductors are susceptible to electrostatic discharges (ESD). Careless handling during repair can reduce life drastically. When repairing, make sure that you are connected with the same potential as the mass of the unit via a wrist wrap with resistance. Keep components and tools also at the same potential !

1. Servicing of SMDs (Surface Mounted Devices)

1.1 General cautions on handling and storage

- Oxidation on the terminals of SMDs results in poor soldering.

Do not handle SMDs with bare hands.

- Avoid using storage places that are sensitive to oxidation such as places with sulphur or chlorine gas, direct sunlight, high temperatures or a high degree of humidity. The capacitance or resistance value of the SMDs may be affected by this.

- Rough handling of circuit boards containing SMDs may cause damage to the components as well as the circuit boards. Circuit boards containing SMDs should never be bent or flexed. Different circuit board materials expand and contract at different rates when heated or cooled and the components and/or solder connections may be damaged due to the stress. Never rub or scrape chip components as this may cause the value of the component to change. Similarly, do not slide the circuit board across any surface.

1.2 Removal of SMDs

- Heat the solder (for 2-3 seconds) at each terminal of the chip. By means of litz wire and a slight horizontal force, small components can be removed with the soldering iron.

They can also be removed with a solder sucker (see Fig. 1A)

Fig. 1 DISMOUNTING

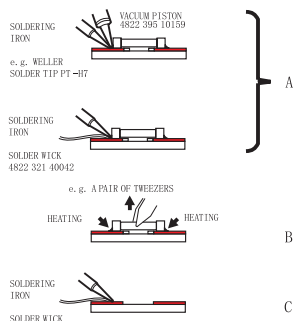

While holding the SMD with a pair of tweezers, take it off gently using the soldering iron's heat applied to each terminal (see Fig. 1 B).

- Remove the excess solder on the solder lands by means of litz wire or a solder sucker (see Fig. 1 C).

1.3 Caution on removal

- When handling the soldering iron, use suitable pressure and be careful.
- When removing the chip, do not use undue force with the pair of tweezers.
- The soldering iron to be used (approx. 30 W) should

preferably be equipped with a thermal control (soldering temperature: 225 to 250 C).

- The chip, once removed, must never be reused.

1.4 Attachment of SMDs

- Locate the SMD on the solder lands by means of tweezers and solder the component on one side. Ensure that the component is positioned correctly on the solder lands (see Fig.2A).

- Next complete the soldering of the terminals of the component (see Fig. 2B).

Fig. 2 MOUNTING

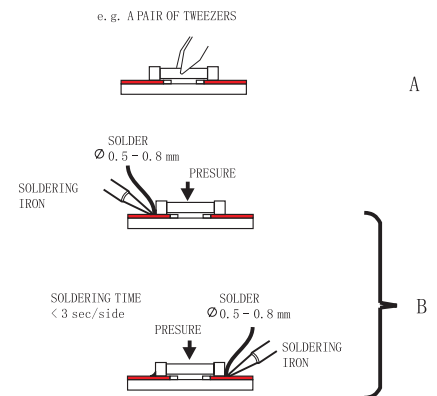

2. Caution when attaching SMDs

- When soldering the SMD terminals, do not touch them directly with the soldering iron. The soldering should be done as quickly as possible, care must be taken to avoid damage to the terminals of the SMDs themselves.

- Keep the SMD's body in contact with the printed board when soldering.

- The soldering iron to be used (approx. 30 W) should preferably be equipped with a thermal control (soldering temperature: 225 to 250 C).

- Soldering should not be done outside the solder land.

- Soldering flux (of rosin) may be used, but should not be acidic.

- After soldering, let the SMD cool down gradually at room temperature.

- The quantity of solder must be proportional to the size of the solder land. If the quantity is too great, the SMD might crack or the solder lands might be torn loose from the printed board (see Fig. 3).

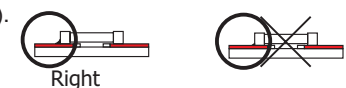
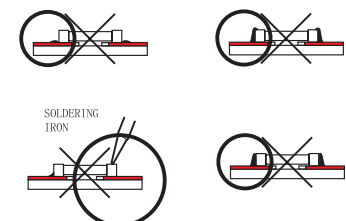

Fig.3 Examples



Repair Tips

3. Lead-free product identification

You can identify lead-free product by Philips-lead-free logo on PCB.



4. Lead-free product repair instruction

4.1 Use only lead-free Solder Alloy 0622 149 00106(1.2mm SAC305) or 0622 14900108(1.0mm SAC305).

Remark: For lead free soldering material, please visit www.alphametals.com website for details. This is recommended by Philips.

4.2 Use only adequate solder tools applicable for lead-free soldering-tin. The solder tool must be able to reach at least a solder-temperature of 400 , to stabilize the adjusted temperature at the solder-tip and to exchange solder-tips for different applications. Small Passives/Actives to be removed with thermal tweezers

Automated system for IC and BGA repair (Microscope, Camera, Beam split optics, Computer, Programmer, Heat controllers, Vacuum system, Laser pointer) Solder Hand-Tool (Adjustable in temperature height, Temperature shall be held constant, Flexible tips)

4.3 Adjust your solder tool so that a temperature around 360 -380 is reached and stabilized at the solder joint.

Heating-time of the solder-joint should not exceed ~ 4 sec. Avoid temperatures above 400 otherwise wear-out of tips will rise drastically and flux-fluid will be destroyed. Corrosion of Tool-Spikes can be avoided when using SAC305 and a temperature of less than 400 .

4.4 Mix of lead-free solder-tin/parts with leaded soldering-tin/parts is possible but not recommended. If not to avoid clean carefully the solder-joint from old tin and re-solder with new tin.

4.5 Use only original spare-parts listed in the Service-Manuals. Standard-material(consumables) can also be purchased at external companies.

4.6 Special information for lead-free BGA-ICs: this ICs will be delivered in so-called dry-packaging to protect the IC against moisture and with lead-free logo on it. This packaging may only be opened shortly before it is used (soldered). Otherwise the body of the IC gets wet inside and during the heating time the structure of the IC will be destroyed due to high (steam-)pressure. If the packaging was opened before usage the IC has to be heated up for some hours (around 90) for drying (Take attention for ESD-protection!)

5. Rework on BGA (Ball Grid Array) ICs

General

Although (LF)BGA assembly yields are very high, there may still be a requirement for component rework. By rework, we mean the process of removing the component from the PWB and replacing it with a new component. If an (LF)BGA is removed from a PWB, the solder balls of the component are deformed drastically so the removed (LF)BGA has to be discarded.

Device Removal

As is the case with any component that, it is essential when removing an (LF)BGA, the board, tracks, solder lands, or surrounding components are not damaged. To remove an (LF)BGA, the board must be uniformly heated to a temperature close to the reflow soldering temperature. A uniform temperature reduces the chance of warping the PWB.

To do this, we recommend that the board is heated until it is certain that all the joints are molten. Then carefully pull the component off the board with a vacuum nozzle. For the appropriate temperature profiles, see the IC data sheet.

Area Preparation

When the component has been removed, the vacant IC area must be cleaned before replacing the (LF)BGA.

Removing an IC often leaves varying amounts of solder on the mounting lands. This excessive solder can be removed with either a solder sucker or solder wick. The remaining flux can be removed with a brush and cleaning agent. After the board is properly cleaned and inspected, apply flux on the solder lands and on the connection balls of the(LF)BGA

Note: Do not apply solder paste, as this has shown to result in problems during re-soldering.

Device Replacement

The last step in the repair process is to solder the new component on the board. Ideally, the (LF)BGA should be aligned under a microscope or magnifying glass. If this is not possible, try to align the (LF)BGA with any board markers.

To reflow the solder, apply a temperature profile according to the IC data sheet. So as not to damage neighbouring components, it may be necessary to reduce some temperatures and times.

More Information

For more information on how to handle BGA devices, visit this URL: <http://www.atyourservice.ce.philips.com> (needs subscription). After login, select Magazine , then go to Workshop Information . Here you will find Information on how to deal with BGA-ICs.

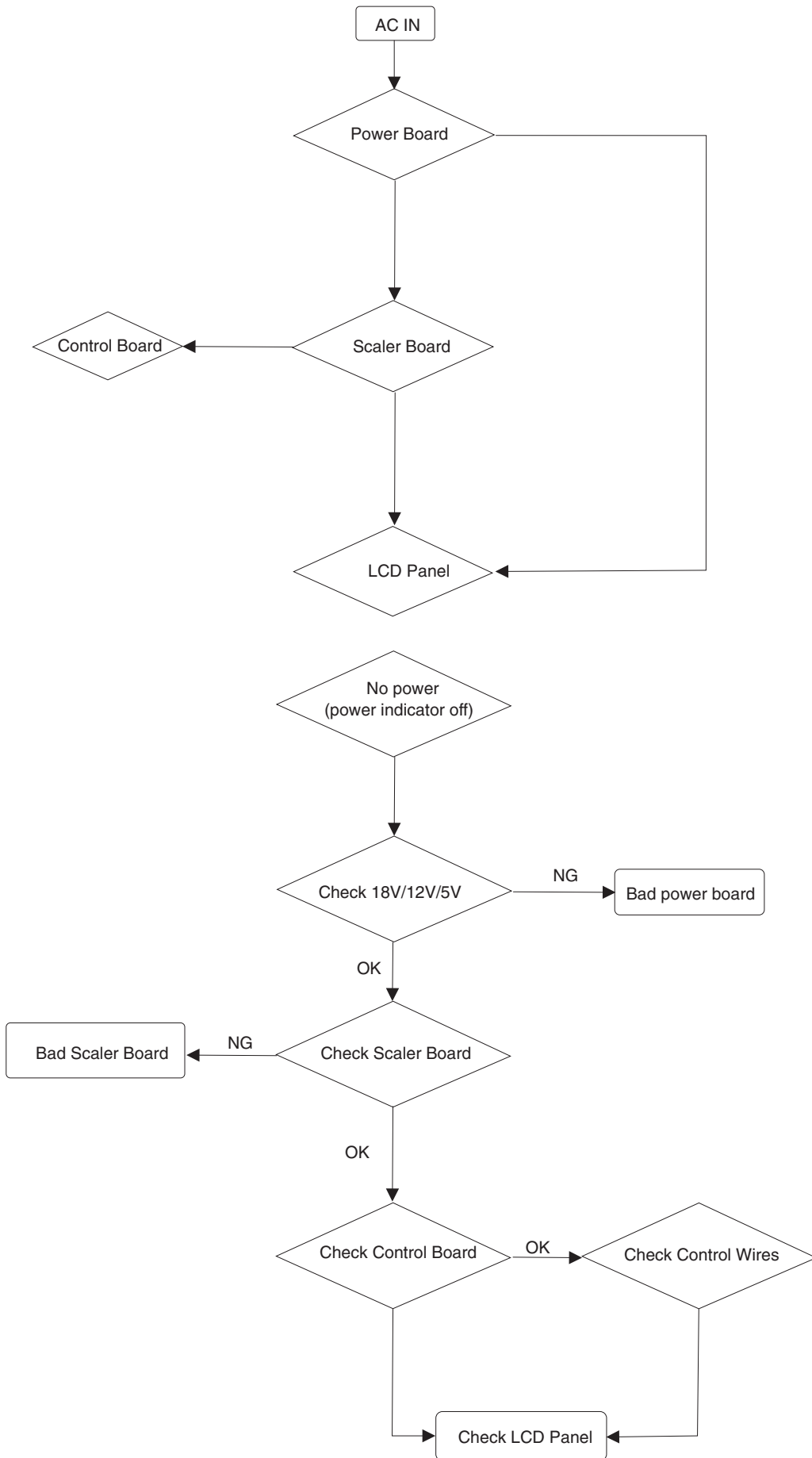

Repair Flow Chart

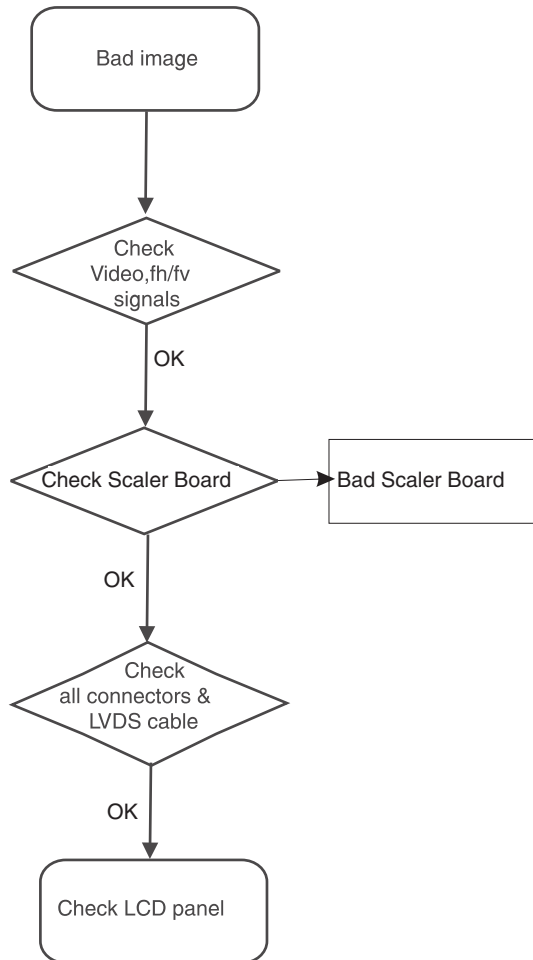
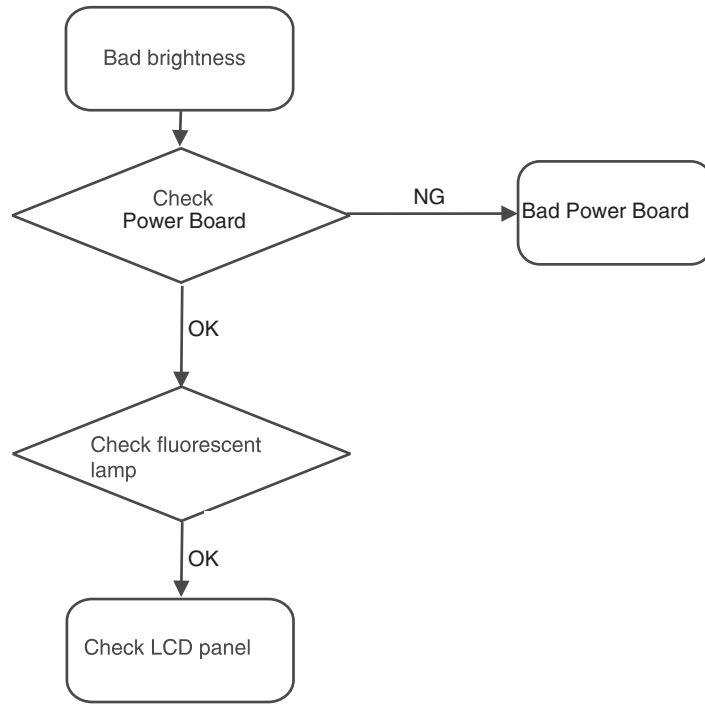

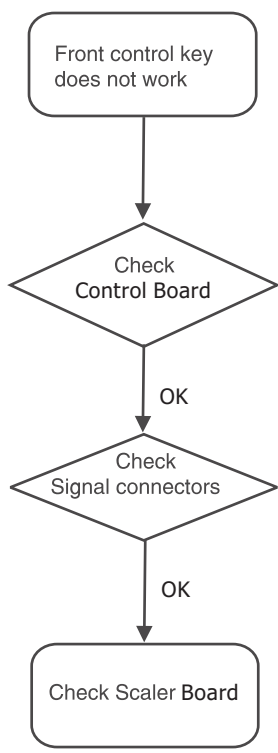
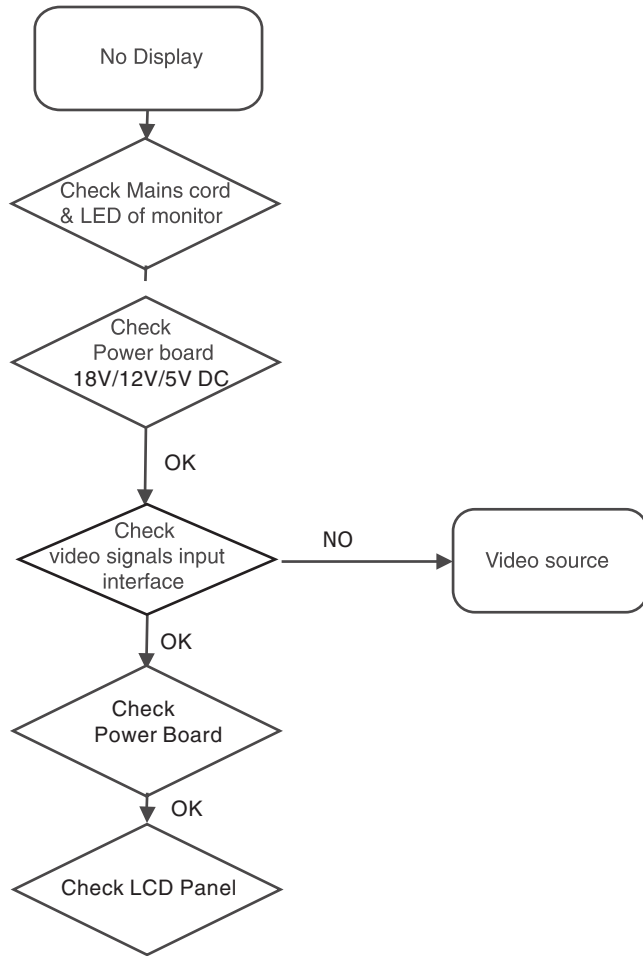

Different Parts List

Diversity of 200WB7ES/69(QDI) compared with 200WB7EB/27(QDI)

Item	12NC	Description
	863900016987	200WB7ES/69
0004	313815761011	SUPER ERGO BASE ASSY
0030	313815760981	BEZEL ASSY
0031	313815417761	BEZEL
0032	313815417771	BEZEL- DECO
0033	313815417781	CONTROL KNOB
0040	313815760991	BACK COVER ASSY
0042	313815417801	MIDDLE COVER
0126	313815569451	RATING LABEL
0460	313815973811	BB PACKING
1051	313815867251	SCALER ASSY(200WB7)
1061	313818871672	MAINSCORD UK 10A 1M8 DET BK
7351	313815867261	CPU IC ASSY
7353	313815867271	EEPROM IC ASSY

Diversity of 200WB7ES/75(QDI) compared with 200WB7EB/27(QDI)

Item	12NC	Description
	863900016988	200WB7ES/75
0004	313815761011	SUPER ERGO BASE ASSY
0030	313815760981	BEZEL ASSY
0031	313815417761	BEZEL
0032	313815417771	BEZEL- DECO
0033	313815417781	CONTROL KNOB
0040	313815760991	BACK COVER ASSY
0042	313815417801	MIDDLE COVER
0126	313815569451	RATING LABEL
0291	313815569481	LABEL
0292	313815569481	LABEL
0615	313811709531	HEX CODE OF F/W(NO MATE REQ)
1051	313815867251	SCALER ASSY
1060	313818873992	CORD SUB-D 15/1M8/15 SUB-D M/M
1061	313819872931	MAINSCORD AUS/NZ 10A 1M8 BK
7351	313815867261	CPU IC ASSY
7353	313815867271	EEPROM IC ASSY

Diversity of 200WB7ES/00(QDI) compared with 200WB7EB/27(QDI)

Item	12NC	Description
	863900016911	200WB7ES/00
0004	313815761011	SUPER ERGO BASE ASSY
0030	313815760981	BEZEL ASSY
0031	313815417761	BEZEL
0032	313815417771	BEZEL- DECO
0033	313815417781	CONTROL KNOB
0040	313815760991	BACK COVER ASSY
0042	313815417801	MIDDLE COVER
0126	313815569451	RATING LABEL
0171	313810600121	FAMILY SHEET- SERVICE
0172	313815550562	PRODUCT TRACEABILITY LABEL
0460	313815973811	BB PACKING
1051	313815867221	SCALER ASSY(200WB7)
1061	313818870471	MAINSCORD IEC 10A 1M8 DET BK
7351	313815867231	CPU IC ASSY
7353	313815867241	EEPROM IC ASSY

Diversity of 200WB7ES/96(QDI) compared with 200WB7EB/27(QDI)

Item	12NC	Description
	863900016991	200WB7ES/96
0001	313810363221	SCALER PCB
0001	313810363321	CONTROL PCB
0001	313810363301	USB PCB
0004	313815761011	SUPER ERGO BASE ASSY
0030	313815760981	BEZEL ASSY
0031	313815417761	BEZEL
0032	313815417771	BEZEL- DECO
0033	313815417781	CONTROL KNOB
0040	313815760991	BACK COVER ASSY
0042	313815417801	MIDDLE COVER
0044	313815162071	CONTACT SPRING
0052	313816877281	ACETATE TAPE
0096	313810041381	SCREW PH K30X8 PT
0097	313810040921	SCREW W/WASHER M3X8
0098	313815040271	SCREW TAPPING M3X5
0099	313816040041	SCREW M3X6 (MACH)
0100	313815040181	SCREW PHM4-0.7X8 TPS
0101	313815040742	SCREW M4X10
0114	313816877281	ACETATE TAPE
0115	313815320271	REINFORCED TAPE
0116	313810440571	HOUSING COVER
0117	313815040481	SCREW PHK30 x 12PT(B)
0126	313815569451	RATING LABEL
0128	313810600803	FAMILY SHEET
0130	313815569641	ENERGY STAR LABEL
0171	313810600121	FAMILY SHEET- SERVICE
0172	313815550562	PRODUCT TRACEABILITY LABEL
0281	062214900106	SOLD WR CR SAC305 1532 1.2MM
0281	062214900106	SOLD WR CR SAC305 1532 1.2MM
0281	062214900106	SOLD WR CR SAC305 1532 1.2MM
0282	062236000001	SOLD BAR SAC305 1KG B
0282	062236000001	SOLD BAR SAC305 1KG B
0282	062236000001	SOLD BAR SAC305 1KG B
0283	132251149002	ISOPROPANOL DENAT 99.7% 200L B
0283	132251149002	ISOPROPANOL DENAT 99.7% 200L B
0283	132251149002	ISOPROPANOL DENAT 99.7% 200L B
0284	132252643001	FLUX SOLD ALPHA RF800 B
0284	132252643001	FLUX SOLD ALPHA RF800 B
0284	132252643001	FLUX SOLD ALPHA RF800 B
0285	132253048502	SOLD PASTE O*310 SN/AG/CU 500G
0285	132252444102	GLUE EP RES RD PD944 SYR.NR8
0285	132252444102	GLUE EP RES RD PD944 SYR.NR8
0286	062235100001	SOLD WR CR SAC405R15 0.8MM 1KG
0286	132250497401	GREASE SILICONE DC4
0286	132250497401	GREASE SILICONE DC4
0287	132252444102	GLUE EP RES RD PD944 SYR.NR8
0287	123810078004	GLUE JETMELT 3748-V0-TC
0287	123810078004	GLUE JETMELT 3748-V0-TC
0288	132251988101	GLUE POLYMER PCB RD PD860002SP
0291	123810078004	GLUE JETMELT 3748-V0-TC
0291	313815569481	LABEL
0292	313815569481	LABEL
0460	313815973811	BB PACKING
0500	083802600004	LLDPE WRAP
0500	083802600004	LLDPE WRAP
0501	283880090385	PALLET wood
0501	313815641971	CLIP SHEET
0503	313810600601	FAMILY SHEET - W/O ADH.
0503	313810600601	FAMILY SHEET - W/O ADH.
0504	313815641911	SLIP SHEET
0504	313815641911	SLIP SHEET
0549	313815683181	PALLET LOADING ASSY
0550	313815683191	SLIP SHEET LOADING ASSY
0615	313811709531	HEX CODE OF F/W(NO MATE REQ)
1051	313815867251	SCALER ASSY
1060	313818873992	CORD SUB-D 15/1M8/15 SUB-D M/M
1061	823827732085	MAINS CORD TWN 7A 1M8 BK
7351	313815867261	CPU IC ASSY
7353	313815867271	EEPROM IC ASSY

Diversity of 200WB7ES/93(QDI) compared with 200WB7EB/27(QDI)

Item	12NC	Description
	863900016989	200WB7ES/93
0004	313815761011	SUPER ERGO BASE ASSY
0030	313815760981	BEZEL ASSY
0031	313815417761	BEZEL
0032	313815417771	BEZEL- DECO
0033	313815417781	CONTROL KNOB
0040	313815760991	BACK COVER ASSY
0042	313815417801	MIDDLE COVER
0126	313815569451	RATING LABEL
0291	313815569481	LABEL
0292	313815569481	LABEL
0615	313811709531	HEX CODE OF F/W(NO MATE REQ)
1051	313815867251	SCALER ASSY
1060	313818873992	CORD SUB-D 15/1M8/15 SUB-D M/M
1061	313818871651	MAINSCORD CCEE 10A 1M8 DET BK
7351	313815867261	CPU IC ASSY
7353	313815867271	EEPROM IC ASSY

Diversity of 200XW7EB/00(QDI) compared with 200WB7EB/27(QDI)

Item	12NC	Description
	867000024587	200XW7EB/00
0004	313815761133	SUPER ERGO BASE ASSY
0030	313815761591	FRONT BEZEL ASSY
0051	313815138321	METAL FRAME
0090	313815136712	AC PLATE
0116	313810440571	HOUSING COVER
0118	313815320701	RUBBER PAD
0126	313815570221	RATING LABEL
0291	313815570231	LABEL
0292	313815570231	LABEL
0450	313815642821	CARTON
0451	313815642231	CUSHION - TOP
0452	313815642241	CUSHION - BUTTON
0453	313815638952	PE (+EPE) BAG
0602	313811709761	EDFU
0615	313811709771	HEX CODE OF F/W(NO MATL REQ)
1051	313815868961	SCALER ASSY-QDI
1057	313815867202	FRAME+WIRE ASSY
1060	313818873992	CORD SUB-D 15/1M8/15 SUB-D M/M
1061	313818870471	MAINSCORD IEC 10A 1M8 DET BK
1351	243854300075	RES XTL SM 12MHZ 32P HC49/S R
2425	823827736069	ELCAP 470UF 16V LZ
3231	232270260101	RST SM 0603 RC21 100R PM5 R
3251	232270260101	RST SM 0603 RC21 100R PM5 R
3254	232270260101	RST SM 0603 RC21 100R PM5 R
5205	242254900601	IND FXD 0603 EMI 100MHZ 30R R
5206	242254900601	IND FXD 0603 EMI 100MHZ 30R R
5207	242254900601	IND FXD 0603 EMI 100MHZ 30R R
6403	933957760683	DIO REC SB140-E3 A (VISH) R
7351	313815868971	CPU IC ASSY
7353	313815868981	EEPROM ASSY

Diversity of 200WB7EB/27(LPL&CPT) compared with 200WB7EB/27(QDI)

Item	Philips 12NC	Description
4	313815761133	SUPER ERGO BASE ASSY
1	CN-313816850	Base
2	CN-313816850	Base Stand
3	CN-313816850	Jig for Base
30	313815761101	BEZEL ASSY
31	313815417961	BEZEL
32	313815417971	BEZEL-DECO
33	313815417981	CONTROL KNOB
40	313815761111	BACK COVER ASSY
41	313815417791	BACK COVER
42	313815417991	MIDDLE COVER
80	313815759083	SHIELDING ASSY
116	313810440571	HOUSING COVER
117	313815040481	SCREW PHK30 x 12PT(B)
118	313815320701	RUBBER PAD
450	313815641834	CARTON

451	313815642231	CUSHION - TOP
452	313815642241	CUSHION - BUTTON
453	313815638952	PE (+EPE) BAG
602	313811709413	E-D.F.U.
1050	823827721031	CLAA201WA03 Q
1050	823827720871	LCD LM201WE3-TLA1
1056	823827732126	VDS CABLE
1057	313815869001	FRAME+WIRE ASSY
1060	313818873992	CORD SUB-D 15/1M8/15 SUB-D M/M
1061	313812874901	MAINSCORD
1064	313819871491	CORD DVI 18+1/1M8/DVI 18+1 BK
1064	089G1748HAAA	DVI-CABLE 1.8M
1050	823827720871	LCD LM201WE3-TLA1
1051	313815869021	SCALER ASSY(200WB7 LPL)
1351	243854300075	RES XTL SM 12MHZ 32P 49S R
2401	202203100206	ELCAP SM HV 25V 47U PM20 R
2413	202203100206	ELCAP SM HV 25V 47U PM20 R
2425	823827736069	EC 470uF 16V LZ 8x11.5mm
2503	202203100206	ELCAP SM HV 25V 47U PM20 R
2506	202203100206	ELCAP SM HV 25V 47U PM20 R
2521	202203100206	ELCAP SM HV 25V 47U PM20 R
2525	202203100206	ELCAP SM HV 25V 47U PM20 R
2527	202203100206	ELCAP SM HV 25V 47U PM20 R
3201	212211805669	RST SM 0603 RC0603 10K PM5 R
3202	232270260102	RST SM 0603 RC21 1K
3203	232270260102	RST SM 0603 RC21 1K
3207	212211805669	RST SM 0603 RC0603 10K PM5 R
3208	212211805669	RST SM 0603 RC0603 10K PM5 R
3209	212211805669	RST SM 0603 RC0603 10K PM5 R
3210	212211805674	RST SM 0603 RC0603 22K PM5 R
3211	212211805643	RST SM 0603 RC0603 100R PM5 R
3212	212211805643	RST SM 0603 RC0603 100R PM5 R
3213	212211805643	RST SM 0603 RC0603 100R PM5 R
3214	212211805643	RST SM 0603 RC0603 100R PM5 R
3229	212211805669	RST SM 0603 RC0603 10K PM5 R
3230	212211805669	RST SM 0603 RC0603 10K PM5 R
3231	212211805643	RST SM 0603 RC0603 100R PM5 R
3233	212211805669	RST SM 0603 RC0603 10K PM5 R
3234	212211805674	RST SM 0603 RC0603 22K PM5 R
3235	212211805643	RST SM 0603 RC0603 100R PM5 R
3236	212211805643	RST SM 0603 RC0603 100R PM5 R
3237	212211805643	RST SM 0603 RC0603 100R PM5 R
3238	212211805643	RST SM 0603 RC0603 100R PM5 R
3239	212211805643	RST SM 0603 RC0603 100R PM5 R
3240	212211805643	RST SM 0603 RC0603 100R PM5 R
3241	232270260222	RST SM 0603 RC21 2K2
3242	232270260222	RST SM 0603 RC21 2K2
3243	232270467509	RST SM 0603 RC22H 75R PM1 R
3244	212211805642	RST SM 0603 RC0603 75R PM5 R
3247	212211805652	RST SM 0603 RC0603 470R PM5 R
3248	232270467509	RST SM 0603 RC22H 75R PM1 R
3249	212211805642	RST SM 0603 RC0603 75R PM5 R
3251	212211805643	RST SM 0603 RC0603 100R PM5 R
3252	212211805642	RST SM 0603 RC0603 75R PM5 R
3253	232270467509	RST SM 0603 RC22H 75R PM1 R
3254	212211805643	RST SM 0603 RC0603 100R PM5 R
3255	232270260102	RST SM 0603 RC21 1K
3256	212211805669	RST SM 0603 RC0603 10K PM5 R
3258	212211805674	RST SM 0603 RC0603 22K PM5 R
3259	212211805674	RST SM 0603 RC0603 22K PM5 R
3351	232270260105	RST SM 0603 RC21 1M
3353	212211805669	RST SM 0603 RC0603 10K PM5 R
3354	212211805643	RST SM 0603 RC0603 100R PM5 R
3359	212211805643	RST SM 0603 RC0603 100R PM5 R
3368	212211805643	RST SM 0603 RC0603 100R PM5 R
3369	212211805643	RST SM 0603 RC0603 100R PM5 R
3370	212211805669	RST SM 0603 RC0603 10K PM5 R
3371	212211805669	RST SM 0603 RC0603 10K PM5 R
3372	212211805669	RST SM 0603 RC0603 10K PM5 R
3373	212211805643	RST SM 0603 RC0603 100R PM5 R
3374	212211805643	RST SM 0603 RC0603 100R PM5 R

Different Parts List

3375	212211805643	RST SM 0603 RC0603 100R PM5 R
3379	212211805643	RST SM 0603 RC0603 100R PM5 R
3391	212211805631	RST SM 0603 JUMP. MAX 0R05 R
3392	212211805631	RST SM 0603 JUMP. MAX 0R05 R
3413	212211805669	RST SM 0603 RC0603 10K PM5 R
3416	212211805643	RST SM 0603 RC0603 100R PM5 R
3419	212211805643	RST SM 0603 RC0603 100R PM5 R
3501	212211805639	RST SM 0603 RC0603 47R PM5 R
3502	212211805639	RST SM 0603 RC0603 47R PM5 R
3503	212211805639	RST SM 0603 RC0603 47R PM5 R
3504	212211805669	RST SM 0603 RC0603 10K PM5 R
3506	212211805643	RST SM 0603 RC0603 100R PM5 R
3507	212211805643	RST SM 0603 RC0603 100R PM5 R
3508	212211805643	RST SM 0603 RC0603 100R PM5 R
3509	212211805647	RST SM 0603 RC0603 220R PM5 R
3510	212211805669	RST SM 0603 RC0603 10K PM5 R
3511	212211805647	RST SM 0603 RC0603 220R PM5 R
3512	212211805669	RST SM 0603 RC0603 10K PM5 R
3515	212211805669	RST SM 0603 RC0603 10K PM5 R
3516	212211805669	RST SM 0603 RC0603 10K PM5 R
3517	232270260104	RST SM 0603 RC21 100K
3518	212211805669	RST SM 0603 RC0603 10K PM5 R
3519	212211805669	RST SM 0603 RC0603 10K PM5 R
3520	212211805669	RST SM 0603 RC0603 10K PM5 R
3521	232270260104	RST SM 0603 RC21 100K
3522	212211805669	RST SM 0603 RC0603 10K PM5 R
3523	212211805674	RST SM 0603 RC0603 22K PM5 R
3524	212211805669	RST SM 0603 RC0603 10K PM5 R
3525	212211805669	RST SM 0603 RC0603 10K PM5 R
3526	212211805669	RST SM 0603 RC0603 10K PM5 R
3527	212211805669	RST SM 0603 RC0603 10K PM5 R
3528	232270260104	RST SM 0603 RC21 100K
3529	212211805669	RST SM 0603 RC0603 10K PM5 R
3534	212211805631	RST SM 0603 JUMP. MAX 0R05 R
3537	212211805631	RST SM 0603 JUMP. MAX 0R05 R
3540	212211805631	RST SM 0603 JUMP. MAX 0R05 R
5201	242254900126	IND FXD 0805 EMI 100MHZ 120R R
5202	242254900126	IND FXD 0805 EMI 100MHZ 120R R
5204	242254900126	IND FXD 0805 EMI 100MHZ 120R R
5205	242254900601	IND FXD 0603 EMI 100MHZ
5206	242254900601	IND FXD 0603 EMI 100MHZ
5207	242254900601	IND FXD 0603 EMI 100MHZ
5351	242254900126	IND FXD 0805 EMI 100MHZ 120R R
5401	242254900126	IND FXD 0805 EMI 100MHZ 120R R
5402	242254900126	IND FXD 0805 EMI 100MHZ 120R R
5403	242254900126	IND FXD 0805 EMI 100MHZ 120R R
5407	242254900126	IND FXD 0805 EMI 100MHZ 120R R
5409	242254900126	IND FXD 0805 EMI 100MHZ 120R R
5410	242254942894	IND FXD 0603 EMI 100MHZ 1K R
5413	242254900482	IND FXD 1206 EMI 100MHZ 80R R
5501	242254900482	IND FXD 1206 EMI 100MHZ 80R R
5502	242254900482	IND FXD 1206 EMI 100MHZ 80R R
6201	932205976685	DIO SIG SM LS4148 (VISH) R
6201	933952510685	DIO SIG SM LL4148 (VISH) R
6202	932205976685	DIO SIG SM LS4148 (VISH) R
6202	933952510685	DIO SIG SM LL4148 (VISH) R
6203	932205976685	DIO SIG SM LS4148 (VISH) R
6203	933952510685	DIO SIG SM LL4148 (VISH) R
6204	932205976685	DIO SIG SM LS4148 (VISH) R
6204	933952510685	DIO SIG SM LL4148 (VISH) R
6403	932220367673	DIO REC SB140A A (VISH) A
6403	932220628682	DIO REC SB140AL-5301 (VISH) B
6403	933957760683	DIO REC SB140 A (VISH) R
7351	313815869031	CPU IC ASSY-LPL
291	313815569083	LABEL
615	313811709931	HEX CODE OF F/W LPL
292	313815569083	LABEL
7353	932214725682	IC M24C16-WBN6P (S)
7403	932222077668	IC SM AME1117ECGTZ (ST00) R
7405	932222076668	IC SM AME1117CCGTZ

7501	932200429685	TRA SIG SM BC857C (ONSE) R
7501	932217439685	TRA SIG SM BC857C (KEC0) R
7502	932200429685	TRA SIG SM BC857C (ONSE) R
7502	932217439685	TRA SIG SM BC857C (KEC0) R
7503	932209265685	TRA SIG SM MUN2211J (ONSE) R
7503	934036790115	TRA SIG SM PDTC114EK (PHSE) R
7506	932209265685	TRA SIG SM MUN2211J (ONSE) R
7506	934036790115	TRA SIG SM PDTC114EK (PHSE) R
7507	932222076668	IC SM AME1117CCGTZ
7509	932209265685	TRA SIG SM MUN2211J (ONSE) R
7509	934036790115	TRA SIG SM PDTC114EK (PHSE) R
1951	243812800196	SWI TACT H=5 GY 160G SKHHAM B
1952	243812800196	SWI TACT H=5 GY 160G SKHHAM B
1953	243812800196	SWI TACT H=5 GY 160G SKHHAM B
1954	243812800196	SWI TACT H=5 GY 160G SKHHAM B
1955	243812800196	SWI TACT H=5 GY 160G SKHHAM B
1956	243812800196	SWI TACT H=5 GY 160G SKHHAM B
1957	243812800196	SWI TACT H=5 GY 160G SKHHAM B
1960	243812800196	SWI TACT H=5 GY 160G SKHHAM B
3951	212211805643	RST SM 0603 RC0603 100R PM5 R
3952	212211805678	RST SM 0603 RC0603 47K PM5 R
3953	212211805669	RST SM 0603 RC0603 10K PM5 R
3954	232270260102	RST SM 0603 RC21 1K
3955	212211805678	RST SM 0603 RC0603 47K PM5 R
3956	212211805669	RST SM 0603 RC0603 10K PM5 R
3957	232270260102	RST SM 0603 RC21 1K
5601	242254900126	IND FXD 0805 EMI 100MHZ 120R R
5602	242254900126	IND FXD 0805 EMI 100MHZ 120R R
5601	242254900126	IND FXD 0805 EMI 100MHZ 120R R
5602	242254900126	IND FXD 0805 EMI 100MHZ 120R R
1051	CBPC6CNMEPSA	SCALER ASSY-CPT
7351	705GZV56013	CPU IC ASSY
291	Z40GA0008131	LABEL
615	Z40GA0008131	HEX CODE OF F/W
7353	705GZV56014	EEPROM IC ASSY
	Z40GA0008132	EEPROM Data
292	Z40GA0008132	LABEL
7353	932214725682	IC M24C16-WBN6P (S)

Diversity of 200WB7ES/69(LPL&CPT) compared with 200WB7EB/27 (QDI&LPL&CPT)

Item	12NC	Description
4	313815761013	SUPER ERGO BASE ASSY
6	CN-313816850	BASE_200W7_SILVER
7	CN-313816850	BASE STAND_200W7_SILVER
8	CN-313816850	JIG for base
30	313815760981	BEZEL ASSY
31	313815417761	BEZEL
33	313815417781	CONTROL KNOB
40	313815760991	BACK COVER ASSY
42	313815417801	MIDDLE COVER
1061	313818871672	MAINSKORD UK 10A 1M8 DET BK
1051	313815869041	SCALER ASSY(200WB7 LPL)
7351	313815869051	CPU IC ASSY-LPL
291	313815569483	LABEL
615	313811709941	HEX CODE OF F/W LPL
7353	313815867271	EEPROM IC ASSY
292	313815569483	LABEL
7351	705GZV56005	CPU IC ASSY
7353	705GZV56006	EEPROM IC ASSY
	Z40GA0008131	EEPROM Data
292	Z40GA0008131	LABEL

Diversity of 200WB7ES/75(LPL&CPT) compared with 200WB7EB/27 (QDI&LPL&CPT)

Item	12NC	Description
4	313815761013	SUPER ERGO BASE ASSY
6	CN-313816850	BASE_200W7_SILVER
7	CN-313816850	BASE STAND_200W7_SILVER
8	CN-313816850	JIG for base
30	313815760981	BEZEL ASSY

31	313815417761	BEZEL
32	313815417771	BEZEL- DECO
33	313815417781	CONTROL KNOB
40	313815760991	BACK COVER ASSY
42	313815417801	MIDDLE COVER
95	313815136721	DSUB PLATE
549	313815683181	PALLET LOADING ASSY
51	313815138241	METAL FRAME
1061	313819872611	MAINSCORD AUS/NZ 7A5 1M8 BK
1061	313819872931	MAINSCORD AUS/NZ 10A 1M8 BK
1051	313815869061	SCALER ASSY(200WB7 LPL)
7351	313815869071	CPU IC ASSY-LPL
291	313815569483	LABEL
615	313811709951	HEX CODE OF F/W LPL
7353	313815867271	EEPROM IC ASSY
292	313815569483	LABEL
7351	705GZV56007	CPU IC ASSY
7353	705GZV56008	EEPROM IC ASSY
	Z40GA0008131	EEPROM Data
292	Z40GA0008131	LABEL

Diversity of 200WB7ES/93(LPL&CPT) compared with 200WB7EB/27(QDI&LPL&CPT)

Item	12NC	Description
	4	313815761013 SUPER ERGO BASE ASSY
	30	313815761321 FRONT BEZEL ASSY (S)
	31	313815417761 BEZEL
	33	313815417781 CONTROL KNOB
	40	313815760991 BACK COVER ASSY
	42	313815417801 MIDDLE COVER
	95	313815136721 DSUB PLATE
	450	313815642384 CARTON
	549	313815683431 PALLET LOADING ASSY
	1061	313818871651 MAINSCORD CCEE 10A 1M8 DET BK
	1051	313815869081 SCALER ASSY(200WB7 LPL)
	7351	313815869091 CPU IC ASSY-LPL
	291	313815569482 LABEL
	615	313811709971 HEX CODE OF F/W LPL
	7353	313815867271 EEPROM IC ASSY
	292	313815569482 LABEL
	7351	705GZV56009 CPU IC ASSY
	7353	705GZV56010 EEPROM IC ASSY
		Z40GA0008131 EEPROM Data
	292	Z40GA0008131 LABEL

Diversity of 200WB7ES/96(LPL&CPT) compared with 200WB7EB/27(QDI&LPL&CPT)

Item	12NC	Description
	4	313815761013 SUPER ERGO BASE ASSY
	6	CN-313816850 BASE_200W7_SILVER
	7	CN-313816850 BASE STAND_200W7_SILVER
	8	CN-313816850 JIG for base
	30	313815760981 BEZEL ASSY
	31	313815417761 BEZEL
	33	313815417781 CONTROL KNOB
	40	313815760991 BACK COVER ASSY
	42	313815417801 MIDDLE COVER
	549	313815683181 PALLET LOADING ASSY
	51	313815138241 METAL FRAME
	1061	823827732085 MAINS CORD TWN 7A 1M8 BK
	1061	823827732135 MAINS CORD TWN 7A 1M8 BK
	1051	313815869101 SCALER ASSY(200WB7 LPL)
	7351	313815869111 CPU IC ASSY-LPL
	291	313815569483 LABEL
	615	313811709981 HEX CODE OF F/W LPL
	7353	313815867271 EEPROM IC ASSY
	292	313815569483 LABEL
	7351	705GZV56011 CPU IC ASSY
	7353	705GZV56012 EEPROM IC ASSY
		Z40GA0008131 EEPROM Data
	292	Z40GA0008131 LABEL

Diversity of 200XW7EB/00(LPL&CPT) compared with 200WB7EB/27(QDI&LPL&CPT)

Item	12NC	Description
	30	313815761592 FRONT BEZEL ASSY
	95	313815136721 DSUB PLATE
	132	P40G70008133 DVI label
	450	313815642823 carton
	602	313811709762 E-D.F.U.
	51	313815138241 METAL FRAME
	1061	313812874931 MAINSCORD
	1061	313818870471 MAINSCORD IEC 10A 1M8 DET BK
	1051	313815869141 SCALER ASSY(200WB7 LPL)
	2425	823827736068 ELCAP 470UF 16V EB
	3231	232270260101 RST SM 0603 RC21 100R
	3251	232270260101 RST SM 0603 RC21 100R
	3254	232270260101 RST SM 0603 RC21 100R
	5205	242254943769 IND FXD 0603 EMI 100MHZ
	5206	242254943769 IND FXD 0603 EMI 100MHZ
	5207	242254943769 IND FXD 0603 EMI 100MHZ
	7351	313815869151 CPU IC ASSY-LPL
	291	313815570231 LABEL
	615	313811709991 HEX CODE OF F/W LPL
	7353	313815868981 EEPROM ASSY
	292	313815570231 LABEL
	7351	705GZV56015 CPU IC ASSY
	291	Z40GA0008132 LABEL
	615	Z40GA0008132 HEX CODE OF F/W
	7353	705GZV56016 EEPROM ASSY

Revision List

Manual 12NC	Release Date	Change Instruction
313810610502	16-Mar.-2006	First release
313810610502	23-Mar.-2006	Update different parts list for 200WB7ES/00(P68).
313810610502	29-Mar.-2006	S/N definition changed(P23)
313810610502	31-Mar.-2006	Update different parts list for 200WB7ES/96(P68).
313810610502	18-Apr.-2006	Due to solve the trail run problem for 200WB7.The difference is as below:

From	1057	313815867201	FRAME+WIRE ASSY
To	1057	313815867202	FRAME+WIRE ASSY

313810610502 27-Apr.-2006 According ECO-CA005956,Add QSG-ergo base and Jig on P.E. bag for Hudson 7.

REF	12NC	Description
1	313815973801	BB DOCUMENT
	863900016912	200WB7EB/27
2	313815974171	BB DOCUMENT
	863900016911	200WB7ES/00
	863900016987	200WB7ES/69
	863900016988	200WB7ES/75
3	313815974691	BB DOCUMENT
	863900016989	200WB7ES/93
4	313815974711	BB DOCUMENT
	863900016991	200WB7ES/96

REF	12NC	Description
1	863900016911	200WB7ES/00
2	863900016912	200WB7EB/27
3	863900016987	200WB7ES/69
4	863900016988	200WB7ES/75
5	863900016989	200WB7ES/93
6	863900016991	200WB7ES/96

REF	CE	Action	Item	12NC	Description
1, 3, 4, 5, 6		From	0004	313815761011	SUPER ERGO BASE ASSY
		To	0004	313815761012	SUPER ERGO BASE ASSY
2		From	0004	313815761131	SUPER ERGO BASE ASSY
		To	0004	313815761132	SUPER ERGO BASE ASSY

REF	CE	Action	Item	12NC	Description
ALL		New	0142	313815524581	QUICK SET GUIDE-ERGO BASE

313810610502 08-May-2006 According ECO-CA006006,Item:960*720 under 1280*720 for priority resolution detection for 200WB7.

REF	12NC	Description
1	313815865841	SCALER ASSY(200WB7)
2	313815867221	SCALER ASSY
3	313815867251	SCALER ASSY
2	863900016911	200WB7ES/00
1	863900016912	200WB7EB/27
3	863900016987	200WB7ES/69
3	863900016988	200WB7ES/75
3	863900016989	200WB7ES/93
3	863900016991	200WB7ES/96

REF	CE	Action	Item	12NC	Description
1		From	291	313815569081	LABEL
		To	291	313815569082	LABEL
2		From	291	313815569461	LABEL
		To	291	313815569462	LABEL
3		From	291	313815569481	LABEL
		To	291	313815569482	LABEL
1		From	615	313811709421	HEX CODE OF F/W(NO MATE REQ)
		To	615	313811709422	HEX CODE OF F/W(NO MATL REQ)
2		From	615	313811709521	HEX CODE OF F/W(NO MATE REQ)
		To	615	313811709522	HEX CODE OF F/W(NO MATL REQ)
3		From	615	313811709531	HEX CODE OF F/W(NO MATE REQ)
		To	615	313811709532	HEX CODE OF F/W(NO MATL REQ)
1		From	292	313815569081	LABEL
		To	292	313815569082	LABEL
2		From	292	313815569461	LABEL
		To	292	313815569462	LABEL
3		From	292	313815569481	LABEL
		To	292	313815569482	LABEL

Revision List

313810610502 01-Jun-2006 According ECO-CA006109, For phase and tail noise improvement (200WB7)

REF	12NC	Description
2	863900016911	200WB7ES/00
1	863900016912	200WB7EB/27
3	863900016987	200WB7ES/69
3	863900016988	200WB7ES/75
3	863900016989	200WB7ES/93
3	863900016991	200WB7ES/96

REF	Action	Item	12NC	Description
ALL	From	1	313810363221	SCALER PCB
	To	1	313810363222	SCALER PCB
ALL	From	2425	202203100205	ELCAP SM RVS 25V 47U PM20 R
			202203100206	ELCAP SM HV 25V 47U PM20 R
	To	2425	823827736068	ELCAP 470UF 16V EB
			823827736069	ELCAP 470UF 16V LZ
ALL	From	3231	212211805642	RST SM 0603 RC0603 75R PM5 R
			232270260759	RST SM 0603 RC21 75R PM5 R
	To	3231	212211805643	RST SM 0603 RC0603 100R PM5 R
			232270260101	RST SM 0603 RC21 100R PM5 R
ALL	From	3251	212211805642	RST SM 0603 RC0603 75R PM5 R
			232270260759	RST SM 0603 RC21 75R PM5 R
	To	3251	212211805643	RST SM 0603 RC0603 100R PM5 R
			232270260101	RST SM 0603 RC21 100R PM5 R
ALL	From	3254	212211805642	RST SM 0603 RC0603 75R PM5 R
			232270260759	RST SM 0603 RC21 75R PM5 R
	To	3254	212211805643	RST SM 0603 RC0603 100R PM5 R
			232270260101	RST SM 0603 RC21 100R PM5 R
ALL	Del	3261	212211805631	RST SM 0603 JUMP. MAX 0R05 R
			232270296001	RST SM 0603 JUMP. MAX 0R05 R
ALL	Del	3262	212211805631	RST SM 0603 JUMP. MAX 0R05 R
			232270296001	RST SM 0603 JUMP. MAX 0R05 R
ALL	Del	3263	212211805631	RST SM 0603 JUMP. MAX 0R05 R
			232270296001	RST SM 0603 JUMP. MAX 0R05 R
ALL	New	5205	242254900601	IND FXD 0603 EMI 100MHZ 30R R
			242254943769	IND FXD 0603 EMI 100MHZ 30R R
ALL	New	5206	242254900601	IND FXD 0603 EMI 100MHZ 30R R
			242254943769	IND FXD 0603 EMI 100MHZ 30R R
ALL	New	5207	242254900601	IND FXD 0603 EMI 100MHZ 30R R
			242254943769	IND FXD 0603 EMI 100MHZ 30R R

313810610502 20-Jun-2006 According ECO-CA006413, Change S/N to 13 digital for Hex code and Document update, implement date on WK626

REF	12NC	Description
2	863900016911	200WB7ES/00
1	863900016912	200WB7EB/27
3	863900016987	200WB7ES/69
3	863900016988	200WB7ES/75
3	863900016989	200WB7ES/93
3	863900016991	200WB7ES/96

REF	Action	Item	12NC	Description
1	From	291	313815569082	LABEL
	To	291	313815569083	LABEL
2	From	291	313815569462	LABEL
	To	291	313815569463	LABEL
3	From	291	313815569482	LABEL
	To	291	313815569483	LABEL
1	From	292	313815569082	LABEL
	To	292	313815569083	LABEL
2	From	292	313815569462	LABEL
	To	292	313815569463	LABEL
3	From	292	313815569482	LABEL
	To	292	313815569483	LABEL
1	From	615	313811709422	HEX CODE OF F/W(NO MATL REQ)
	To	615	313811709423	HEX CODE OF F/W(NO MATL REQ)
2	From	615	313811709522	HEX CODE OF F/W(NO MATL REQ)
	To	615	313811709523	HEX CODE OF F/W(NO MATL REQ)
3	From	615	313811709532	HEX CODE OF F/W(NO MATL REQ)
	To	615	313811709533	HEX CODE OF F/W(NO MATL REQ)