

Service
Service
Service



192E2SB/00	192E2SB/94
192E2SB/10 (AP)	192E2SB/75
192E2SB/10	192E2SB/93
192E2SB/27	192E2SB/70
192E2SB/00 (AP)	192E2SB/96
192E2SB/69	192E2SB/01
192E2SB/71	192E2SB/67
192E2SB/73	192E2SB/62



Service Manual

Horizontal frequencies
30 - 83 kHz

TABLE OF CONTENTS

Description	Page	Description	Page
Important Safety Notice-----	2	Failure Mode Of Panel -----	38
Technical Data-----	3~6	Wiring Diagram-----	39
Installation-----	7	Block Diagram-----	40
Troubleshooting-----	8~9	Scaler Diagram & C.B.A. -----	41~46
On Screen Display-----	10~11	Power Diagram & C.B.A. -----	47~50
Lock/unlock, Aging,Factory mode-----	12	Control Diagram & C.B.A. -----	51~52
Philips Pixel Defect Policy -----	13	General product specification-----	53~82
Mechanical Instructions -----	14~17	Exploded View -----	83
Color adjustment -----	18	Spare/ Recommended Parts List-----	84~86
FAQs (Frequently Asked Questions)-----	19~20	PCBA photos-----	87
Electrical instruction -----	21~22	Repair tips-----	88~89
Service Tool-----	23~24	Repair Flow chart-----	90~91
DDC Instructions & Serial Number -----	25~31	Safety Test Requirments-----	92
DDC DATA -----	32~33		
Firmware Upgrade for CPU- -----	34~37		

SAFETY NOTICE

ANY PERSON ATTEMPTING TO SERVICE THIS CHASSIS MUST FAMILIARIZE HIMSELF WITH THE CHASSIS AND BE AWARE OF THE NECESSARY SAFETY PRECAUTIONS TO BE USED WHEN SERVICING ELECTRONIC EQUIPMENT CONTAINING HIGH VOL TAGES.

CAUTION: USE A SEPARATE ISOLATION TRANSFORMER FOR THIS UNIT WHEN SERVICING.

REFER TO BACK COVER FOR IMPORTANT SAFETY GUIDELINES

Important Safety Notice

Proper service and repair is important to the safe, reliable operation of all Philips Consumer Electronics Company equipment. The service procedures recommended by Philips and described in this service manual are effective methods of performing service operations. Some of these service operations require the use of tools specially designed for the purpose. The special tools should be used when and as recommended.

It is important to note that this manual contains various CAUTIONS and NOTICES which should be carefully read in order to minimize the risk of personal injury to service personnel. The possibility exists that improper service methods may damage the equipment. It is also important to understand that these CAUTIONS and NOTICES ARE NOT EXHAUSTIVE. Philips could not possibly know, evaluate and advise the service trade of all conceivable ways in which service might be done or of the possible hazardous consequences of each way. Consequently, Philips has not undertaken any such broad evaluation. Accordingly, who uses a service procedure or tool which is not recommended by Philips must first satisfy himself thoroughly that neither his safety nor the safe operation of the equipment will be jeopardized by the service method selected.

** Hereafter throughout this manual, Philips Consumer Electronics Company will be referred to as Philips. **

WARNING

Critical components having special safety characteristics are identified with a by the Ref. No. in the parts list and enclosed within a broken line

(where several critical components are grouped in one area) along with the safety symbol on the schematics or exploded views.

Use of substitute replacement parts which do not have the same specified safety characteristics may create shock, fire, or other hazards.

Under no circumstances should the original design be modified or altered without written permission from Philips. Philips assumes no liability, express or implied, arising out of any unauthorized modification of design.

Service assumes all liability.

FOR PRODUCTS CONTAINING LASER :

- DANGER - Invisible laser radiation when open.
AVOID DIRECT EXPOSURE TO BEAM.
- CAUTION - Use of controls or adjustments or performance of procedures other than those specified herein may result in hazardous radiation exposure.
- CAUTION - The use of optical instruments with this product will increase eye hazard.

TO ENSURE THE CONTINUED RELIABILITY OF THIS PRODUCT, USE ONLY ORIGINAL MANUFACTURER'S REPLACEMENT PARTS, WHICH ARE LISTED WITH THEIR PART NUMBERS IN THE PARTS LIST SECTION OF THIS SERVICE MANUAL.

Take care during handling the LCD module with backlight unit

- Must mount the module using mounting holes arranged in four corners.
- Do not press on the panel, edge of the frame strongly or electric shock as this will result in damage to the screen.
- Do not scratch or press on the panel with any sharp objects, such as pencil or pen as this may result in damage to the panel.
- Protect the module from the ESD as it may damage the electronic circuit (C -MOS).
- Make certain that treatment body are grounded through wrist band.
- Do not leave the module in high temperature and in areas of high humidity for a long time.
- Avoid contact with water as it may ashort circuit within the module.
- If the surface of panel become dirty, please wipe it off with a soft material. (Cleaning with a dirty or rough cloth may damage the panel.)

Technical Data

SEC

Type NR. : SEC LTM185AT01
 Resolution : 1366x768
 Outside dimensions : 430.4(H) x 254.6(V) x 16.5(D) mm
 Pitch (mm) : 0.300mm x 0.300mm
 Color pixel arrangement : 1366 horizontal By 768 vertical Pixels
 Display surface : Hard coating (3H), Anti-glare treatment
 Color depth : 16.7M (6 bit with H-FRC)
 Backlight : 2 CCFL
 Active area (W x H) : 409.8mm (H) x230.4mm (V) mm
 View angle (CR=10) : >=160 for Right/Left (Typ)
 : >=160 for Up/Down (Typ)
 Contrast ratio : >=1000:1 (Typ)
 White luminance : 250 (center,Typ)
 Color gamut : >=72%
 Gate IC : LDI
 Source IC : N/A
 Response time : 5 ms (Typ)
 Vertical frequency range : 47~75Hz

Scanning frequencies

Hor.: 30 – 83 K Hz
 Ver.: 56 - 76 Hz
 Video dot rate: < 140 MHz for VGA and < 140 MHz for DVI
 Power input: 90-264 V AC, 50/60 ± 2 Hz

Power consumption: Normal on: < 30 W (max)

Functions:

- (1) D-SUB analog R/G/B separate inputs, H/V sync separated, Composite (H+V) TTL level, SOG sync.
- (2) DVI digital Panel Link TMDS inputs, HDCP supported.

Ambient temperature: 0 °C - 40 °C

Power input connection

Power cord length : 1.8 M
 Power cord type : 3 leads power cord with protective earth plug.

Power management

The monitor must comply with the Microsoft On Now specification, and meet EPA requirements.

Mode	HSYN C	VSYN C	Video	Pwr-con s.	Indicatio n	Rec . tim e
Power-On	On	On	active	<30 W (max.)	White LED	--
Power Saving	Off	Off	blanked	< 0.5W	Blinking White LED Period: 1sec On, 3sec Off	<3s
DC Power Off			N/A	< 0.5 W	LED Off	

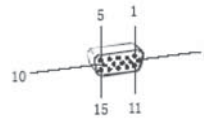

PIN No.	SIGNAL	PIN No.	SIGNAL
1	Red	9	DDC +3.3V or +5V
2	Green/ SOG	10	Logic GND
3	Blue	11	Sense (GND)
4	Sense (GND)	12	Bi-directional data
5	Cable Detect (GND)	13	H/H+V sync
6	Red GND	14	V-sync
7	Green GND	15	Data clock
8	Blue GND		

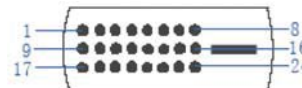

Pin No.	Description
1	T.M.D.S. data2-
2	T.M.D.S. data2+
3	T.M.D.S. data2 shield
4	No Connect
5	No Connect
6	DDC clock
7	DDC data
8	No Connect
9	T.M.D.S. data1-
10	T.M.D.S. data1+
11	T.M.D.S. data1 shield
12	No Connect
13	No Connect
14	+5V Power
15	Ground (for +5V)
16	Hot plug detect
17	T.M.D.S. data0-
18	T.M.D.S. data0+
19	T.M.D.S. data0 shield
20	No Connect
21	No Connect
22	T.M.D.S. clock shield
23	T.M.D.S. clock+
24	T.M.D.S. clock-

Susceptibility of display to external environment

Operating

- Temperature : 0 to 40 degree C
- Humidity : 80% max
- Altitude : 0-3658m
- Air pressure : 600-1100 mBAR

Storage

- Temperature : -20 to 60 degree C
- Humidity : 95% max
- Altitude : 0-12192m
- Air pressure : 300-1100 mBAR

Note: recommend at 5 to 35°C, Humidity less than 60 %

Technical Data

CMO

Type NR. : CMO M185B1-L02
 Resolution : 1366x768
 Outside dimensions : 430.4(H) x 254.6(V) x 16.25(D)
 Pitch (mm) : 0.300mm x 0.300mm
 Color pixel arrangement : 1366 horizontal By 768 vertical Pixels. RGB stripe
 Display surface : Hard coating (3H), Anti-glare treatment
 Color depth : 16.7M (6-bit with H-FRC)
 Backlight : 2 CCFL
 Active area (W x H) : 409.8mm (H) x 230.4mm (V) mm
 View angle (CR=10) : >=160 for Right/Left (Typ)
 : >=160 for Up/Down (Typ)
 Contrast ratio : >=1000:1 (Typ)
 White luminance : 250 (center, Typ)
 Color gamut : >=72%
 Gate IC : HiMax/Novatek
 Source IC : HiMax
 Response time : 5 ms (Typ)
 Vertical frequency range : 40~75Hz

Scanning frequencies

Hor.: 30 – 83 K Hz
 Ver.: 56 - 76 Hz
 Video dot rate: < 140 MHz for VGA and < 140 MHz for DVI
 Power input: 90-264 V AC, 50/60 ± 2 Hz

Power consumption: Normal on: < 30 W (max)

Functions:

- (1) D-SUB analog R/G/B separate inputs, H/V sync separated, Composite (H+V) TTL level, SOG sync.
- (2) DVI digital Panel Link TMDS inputs, HDCP supported.

Ambient temperature: 0 °C - 40 °C

Power input connection

Power cord length : 1.8 M
 Power cord type : 3 leads power cord with protective earth plug.

Power management

The monitor must comply with the Microsoft On Now specification, and meet EPA requirements.

Mode	HSYN C	VSYN C	Video	Pwr-con s.	Indicatio n	Rec . time
Power-On	On	On	active	<30 W (max.)	White LED	--
Power Saving	Off	Off	blanked	< 0.5W	Blinking White LED Period: 1sec On, 3sec Off	<3s
DC Power Off			N/A	< 0.5 W	LED Off	

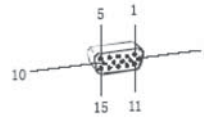

PIN No.	SIGNAL	PIN No.	SIGNAL
1	Red	9	DDC +3.3V or +5V
2	Green/ SOG	10	Logic GND
3	Blue	11	Sense (GND)
4	Sense (GND)	12	Bi-directional data
5	Cable Detect (GND)	13	H/H+V sync
6	Red GND	14	V-sync
7	Green GND	15	Data clock
8	Blue GND		

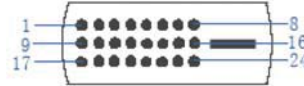

Pin No.	Description
1	T.M.D.S. data2-
2	T.M.D.S. data2+
3	T.M.D.S. data2 shield
4	No Connect
5	No Connect
6	DDC clock
7	DDC data
8	No Connect
9	T.M.D.S. data1-
10	T.M.D.S. data1+
11	T.M.D.S. data1 shield
12	No Connect
13	No Connect
14	+5V Power
15	Ground (for +5V)
16	Hot plug detect
17	T.M.D.S. data0-
18	T.M.D.S. data0+
19	T.M.D.S. data0 shield
20	No Connect
21	No Connect
22	T.M.D.S. clock shield
23	T.M.D.S. clock+
24	T.M.D.S. clock-

Susceptibility of display to external environment

Operating

- Temperature : 0 to 40 degree C
- Humidity : 80% max
- Altitude : 0-3658m
- Air pressure : 600-1100 mBAR

Storage

- Temperature : -20 to 60 degree C
- Humidity : 95% max
- Altitude : 0-12192m
- Air pressure : 300-1100 mBAR

Note: recommend at 5 to 35°C, Humidity less than 60 %

Technical Data

AUO

Type NR. : AUO M185XW01 VB
 Resolution : 1366x768
 Outside dimensions : 430.4(H) x 254.6(V) x 11(D) mm
 Pitch (mm) : 0.300mm x 0.300mm
 Color pixel arrangement : 1366 horizontal By 768 vertical Pixels
 Display surface : Hard coating (3H), Anti-glare treatment
 Color depth : 16.7M (6 bit with H-FRC)
 Backlight : 2 CCFL
 Active area (W x H) : 409.8mm (H) x 230.4mm (V) mm
 View angle (CR=10) : >=160 for Right/Left (Typ)
 : >=160 for Up/Down (Typ)
 Contrast ratio : >=1000:1 (Typ)
 White luminance : 250 (center, Typ)
 Color gamut : >=72%
 Gate IC : LDI
 Source IC : N/A
 Response time : 5 ms (Typ)
 Vertical frequency range : 47~75Hz

Scanning frequencies

Hor.: 30 – 83 K Hz
 Ver.: 56 - 76 Hz
 Video dot rate: < 140 MHz for VGA and < 140 MHz for DVI
 Power input: 90-264 V AC, 50/60 ± 2 Hz

Power consumption: Normal on: < 30 W (max)

Functions:

- (1) D-SUB analog R/G/B separate inputs, H/V sync separated, Composite (H+V) TTL level, SOG sync.
- (2) DVI digital Panel Link TMDS inputs, HDCP supported.

Ambient temperature: 0 °C - 40 °C

Power input connection

Power cord length : 1.8 M
 Power cord type : 3 leads power cord with protective earth plug.

Power management

The monitor must comply with the Microsoft On Now specification, and meet EPA requirements.

Mode	HSYN C	VSYN C	Video	Pwr-con s.	Indicatio n	Rec . time
Power-On	On	On	active	<30 W (max.)	White LED	--
Power Saving	Off	Off	blanked	< 0.5W	Blinking White LED Period: 1sec On, 3sec Off	<3s
DC Power Off			N/A	< 0.5 W	LED Off	

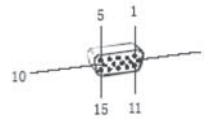

PIN No.	SIGNAL	PIN No.	SIGNAL
1	Red	9	DDC +3.3V or +5V
2	Green/ SOG	10	Logic GND
3	Blue	11	Sense (GND)
4	Sense (GND)	12	Bi-directional data
5	Cable Detect (GND)	13	H/H+V sync
6	Red GND	14	V-sync
7	Green GND	15	Data clock
8	Blue GND		



Pin No.	Description
1	T.M.D.S. data2-
2	T.M.D.S. data2+
3	T.M.D.S. data2 shield
4	No Connect
5	No Connect
6	DDC clock
7	DDC data
8	No Connect
9	T.M.D.S. data1-
10	T.M.D.S. data1+
11	T.M.D.S. data1 shield
12	No Connect
13	No Connect
14	+5V Power
15	Ground (for +5V)
16	Hot plug detect
17	T.M.D.S. data0-
18	T.M.D.S. data0+
19	T.M.D.S. data0 shield
20	No Connect
21	No Connect
22	T.M.D.S. clock shield
23	T.M.D.S. clock+
24	T.M.D.S. clock-

Susceptibility of display to external environment

Operating

- Temperature : 0 to 40 degree C
- Humidity : 80% max
- Altitude : 0-3658m
- Air pressure : 600-1100 mBAR

Storage

- Temperature : -20 to 60 degree C
- Humidity : 95% max
- Altitude : 0-12192m
- Air pressure : 300-1100 mBAR

Note: recommend at 5 to 35°C, Humidity less than 60 %

Technical Data

CPT

Type NR. : CPT CLAA185WA03 V2
 Resolution : 1366x768
 Outside dimensions : 430.4(H) x 254.6(V) x 16.5(D)
 Pitch (mm) : 0.300mm x 0.300mm
 Color pixel arrangement : 1366 horizontal By 768 vertical Pixels. RGB stripe
 Display surface : Hard coating (3H), Anti-glare treatment
 Color depth : 16.7M (6-bit with H-FRC)
 Backlight : 2 CCFL
 Active area (W x H) : 409.8mm (H) x230.4mm (V) mm
 View angle (CR=10) : >=160 for Right/Left (Typ)
 : >=160 for Up/Down (Typ)
 Contrast ratio : >=1000:1 (Typ)
 White luminance : 250 (center, Typ)
 Color gamut : >=72%
 Gate IC : HiMax/Novatek
 Source IC : HiMax
 Response time : 5 ms (Typ)
 Vertical frequency range : 40~75Hz

Scanning frequencies

Hor.: 30 – 83 K Hz
 Ver.: 56 - 76 Hz
 Video dot rate: < 140 MHz for VGA and < 140 MHz for DVI
 Power input: 90-264 V AC, 50/60 ± 2 Hz

Power consumption: Normal on: < 30 W (max)

Functions:

- (1) D-SUB analog R/G/B separate inputs, H/V sync separated, Composite (H+V) TTL level, SOG sync.
- (2) DVI digital Panel Link TMDS inputs, HDCP supported.

Ambient temperature: 0 °C - 40 °C

Power input connection

Power cord length : 1.8 M
 Power cord type : 3 leads power cord with protective earth plug.

Power management

The monitor must comply with the Microsoft On Now specification, and meet EPA requirements.

Mode	HSYN C	VSYN C	Video	Pwr-con s.	Indicatio n	Rec . time
Power-On	On	On	active	<30 W (max.)	White LED	--
Power Saving	Off	Off	blanked	< 0.5W	Blinking White LED Period: 1sec On, 3sec Off	<3s
DC Power Off			N/A	< 0.5 W	LED Off	

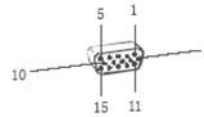

PIN No.	SIGNAL	PIN No.	SIGNAL
1	Red	9	DDC +3.3V or +5V
2	Green/ SOG	10	Logic GND
3	Blue	11	Sense (GND)
4	Sense (GND)	12	Bi-directional data
5	Cable Detect (GND)	13	H/H+V sync
6	Red GND	14	V-sync
7	Green GND	15	Data clock
8	Blue GND		

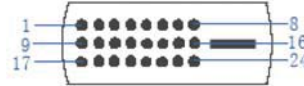

Pin No.	Description
1	T.M.D.S. data2-
2	T.M.D.S. data2+
3	T.M.D.S. data2 shield
4	No Connect
5	No Connect
6	DDC clock
7	DDC data
8	No Connect
9	T.M.D.S. data1-
10	T.M.D.S. data1+
11	T.M.D.S. data1 shield
12	No Connect
13	No Connect
14	+5V Power
15	Ground (for +5V)
16	Hot plug detect
17	T.M.D.S. data0-
18	T.M.D.S. data0+
19	T.M.D.S. data0 shield
20	No Connect
21	No Connect
22	T.M.D.S. clock shield
23	T.M.D.S. clock+
24	T.M.D.S. clock-

Susceptibility of display to external environment

Operating

- Temperature : 0 to 40 degree C
- Humidity : 80% max
- Altitude : 0-3658m
- Air pressure : 600-1100 mBAR

Storage

- Temperature : -20 to 60 degree C
- Humidity : 95% max
- Altitude : 0-12192m
- Air pressure : 300-1100 mBAR

Note: recommend at 5 to 35°C, Humidity less than 60 %

Installation

Front View Product Description

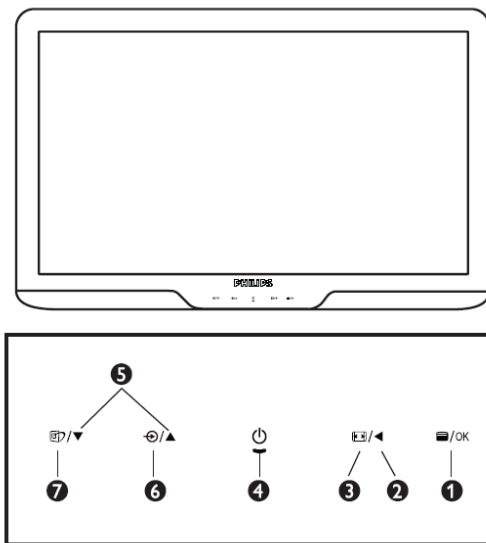

- 1** /OK: To access OSD menu.
- 2** : Return to previous OSD level.
- 3** : Change to 4:3 display.
- 4** : To switch monitor's power on and off.
- 5** : To adjust the OSD menu.
- 6** : To change the signal input.
- 7** : SmartImage Lite. There are 3 modes to be selected: Office, Standard, Internet and Game.

Accessory Pack

Unpack all the parts

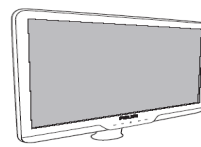

Monitor



Quick start guide



Base stand



EDFU CD



Power cord



VGA signal cable (optional)



DVI cable (optional)

Connecting to Your PC

1) Connect the power cord to the back of the monitor firmly. (Philips has pre-connected VGA cable for the first installation.)

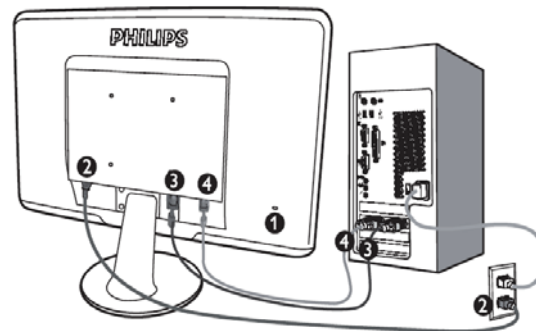

Rear View

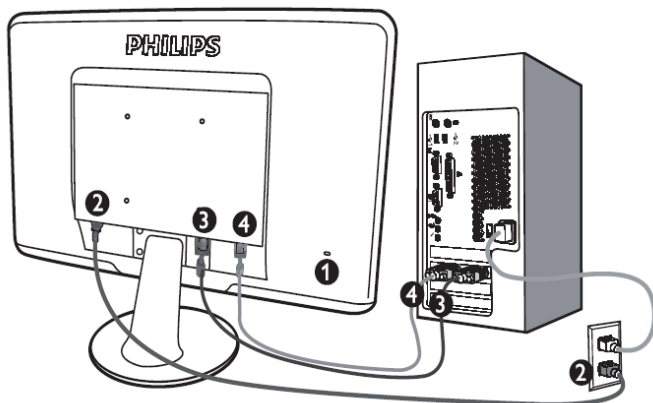

- 1** Kensington anti-theft lock
- 2** AC power input
- 3** DVI-D input (available for selecting model)
- 4** VGA input

- 1** Kensington anti-theft lock
- 2** AC power input
- 3** DVI-D input (available for selecting model)
- 4** VGA input

Connect to PC

1. Connect the power cord to the back of the monitor firmly.
2. Turn off your computer and unplug its power cable.
3. Connect the monitor signal cable to the video connector on the back of your computer.
4. Plug the power cord of your computer and your monitor into a nearby outlet.
5. Turn on your computer and monitor. If the monitor displays an image, installation is complete.

Troubleshooting

7 Troubleshooting & FAQs

7.1 Troubleshooting

This page deals with problems that can be corrected by a user. If the problem still persists after you have tried these solutions, contact Philips customer service representative.

1 Common Problems

No Picture (Power LED not lit)

- Make sure the power cord is plugged into the power outlet and into the back of the monitor.
- First, ensure that the power button on the front of the monitor is in the OFF position, then press it to the ON position.

No Picture (Power LED is white blinking)

- Make sure the computer is turned on.
- Make sure the signal cable is properly connected to your computer.
- make sure the monitor cable has no bent pins on the connect side. If yes, repair or replace the cable.
- The Energy Saving feature may be activated

Screen says

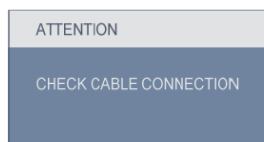

- Make sure the monitor cable is properly connected to your computer. (Also refer to the Quick Set-Up Guide).
- Check to see if the monitor cable has bent pins.
- Make sure the computer is turned on.

AUTO button doesn't function

- The auto function is applicable only in VGA-Analog mode. If the result is not satisfactory, you can do manual adjustments via the OSD menu.

Note

The Auto Function is not applicable in DVI-Digital mode as it is not necessary.

Visible signs of smoke or sparks

- Do not perform any troubleshooting steps
- Disconnect the monitor from mains power source immediately for safety
- Contact with Philips customer service representative immediately.

2 Imaging Problems

Image is not centered

- Adjust the image position using the "Auto" function in OSD Main Controls.
- Adjust the image position using the Phase/Clock of Setup in OSD Main Controls. It is valid only in VGA mode.

Image vibrates on the screen

- Check that the signal cable is properly securely connected to the graphics board or PC.

Vertical flicker appears



- Adjust the image using the "Auto" function in OSD Main Controls.
- Eliminate the vertical bars using the Phase/Clock of Setup in OSD Main Controls. It is valid only in VGA mode.

Troubleshooting

Horizontal flicker appears



- Adjust the image using the "Auto" function in OSD Main Controls.
- Eliminate the vertical bars using the Phase/Clock of Setup in OSD Main Controls. It is valid only in VGA mode.

Image appears blurred, indistinct or too dark

- Adjust the contrast and brightness on On-Screen Display.

An "after-image", "burn-in" or "ghost image" remains after the power has been turned off.

- Uninterrupted display of still or static images over an extended period may cause "burn in", also known as "after-imaging" or "ghost imaging", on your screen. "Burn-in", "after-imaging", or "ghost imaging" is a well-known phenomenon in LCD panel technology. In most cases, the "burned in" or "after-imaging" or "ghost imaging" will disappear gradually over a period of time after the power has been switched off.
- Always activate a moving screen saver program when you leave your monitor unattended.
- Always activate a periodic screen refresh application if your LCD monitor will display unchanging static content.
- Severe "burn-in" or "after-image" or "ghost image" symptoms will not disappear and cannot be repaired. The damage mentioned above is not covered under your warranty.

Image appears distorted. Text is fuzzy or blurred.

- Set the PC's display resolution to the same mode as monitor's recommended screen native resolution.

Green, red, blue, dark, and white dots appears on the screen

- The remaining dots are normal characteristic of the liquid crystal used in today's technology. Please refer the pixel policy for more detail.

The "power on" light is too strong and is disturbing

- You can adjust "power on" light using the power LED Setup in OSD main Controls.

For further assistance, refer to the Consumer Information Centers list and contact Philips customer service representative.

On-Screen Display

Description of the On Screen Display

What is the On-Screen Display?

On-Screen Display (OSD) is a feature in all Philips LCD monitors. It allows an end user to adjust screen performance or select functions of the monitors directly through an on-screen instruction window. A user friendly on screen display interface is shown as below :



Basic and simple instruction on the control keys.

In the OSD shown above users can press ▼▲ buttons at the front bezel of the monitor to move the cursor, **OK** to confirm the choice or change.

On-Screen Display

The OSD Tree

Below is an overall view of the structure of the On-Screen Display. You can use this as a reference when you want to work your way around the different adjustments later on.

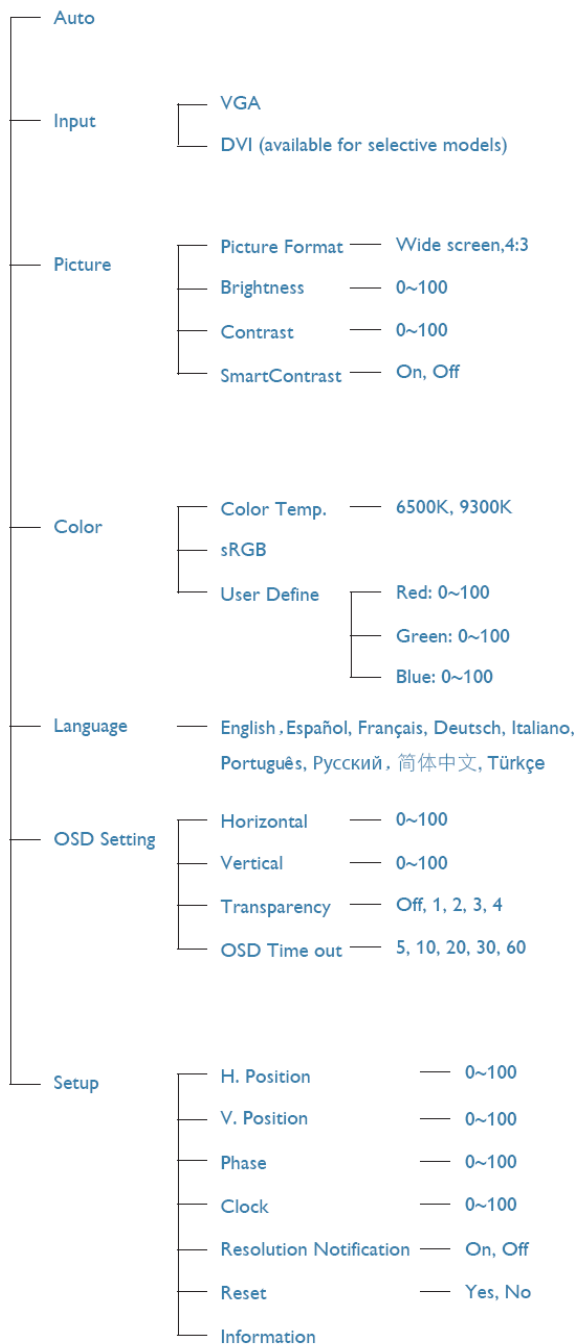

Resolution notification

This monitor is designed for optimal performance at its native resolution, 1920X1080@60Hz. When the monitor is powered on at a different resolution, an alert is displayed on screen: Use 1920X1080@60Hz for best results.

Display of the native resolution alert can be switched off from Setup in the OSD (On Screen Display) menu.

Lock/Unlock,Aging,Factory Mode

To lock/unlock OSD FUNCTION(User Mode)

The OSD function can be locked by pressing "OK" button(1) for more than 10 seconds, the screen shows following windows for 4 seconds. Every time when you press "OK" button, this message appears on the screen automatically .

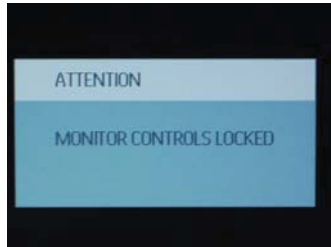

Unlock OSD function

Unlocked OSD function can be released by pressing "OK" button for more than 10 seconds again.

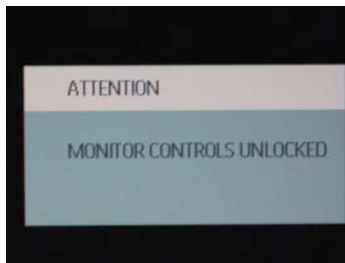

Access Factory Mode

- 1). Turn off monitor.
- 2). [Push "EXIT" & "MENU" buttons at the same time and hold them]+[Press "power" button until comes out "Windows screen"] => then release all buttons
- 3). Press "MENU" button, wait until the OSD menu with Characters "MERIDIAN 192E2 V1.0 2010-05-14" (below OSD menu) come on the Screen of the monitor.

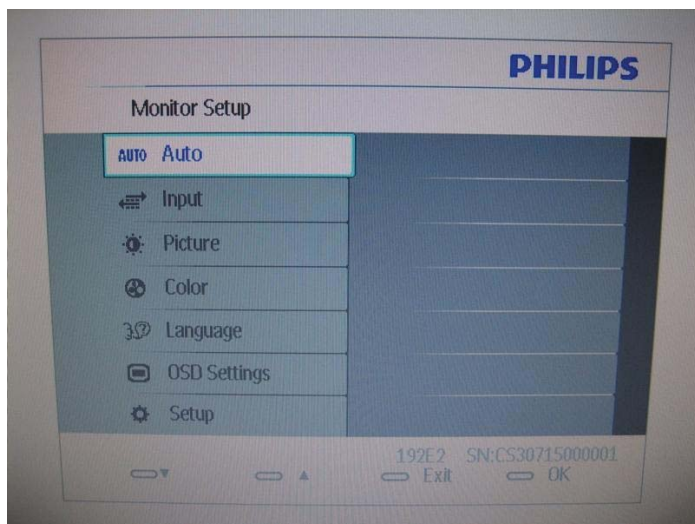

Factory Mode indicator

Factory Menu

Cursor can move on gray color area

Hot key function: by pressing " UP " and " DOWN " key Simultaneously at User Mode (or Factory Mode) (PS: The Offset R G B function can be used on reduce or eliminate snowy noise on the background when the resolution of video signal is 1680*1050vertical 60Hz. Slightly increase or decrease the value until snowy noise completely disappear .

Access Aging Mode

Step 1 : Access Factory Mode then enter Factory Menu.

Step 2 : By pressing " UP " and " DOWN " key to Burning Icon. Press "MENU then press " UP " and " DOWN " key to turn on Aging Mode.

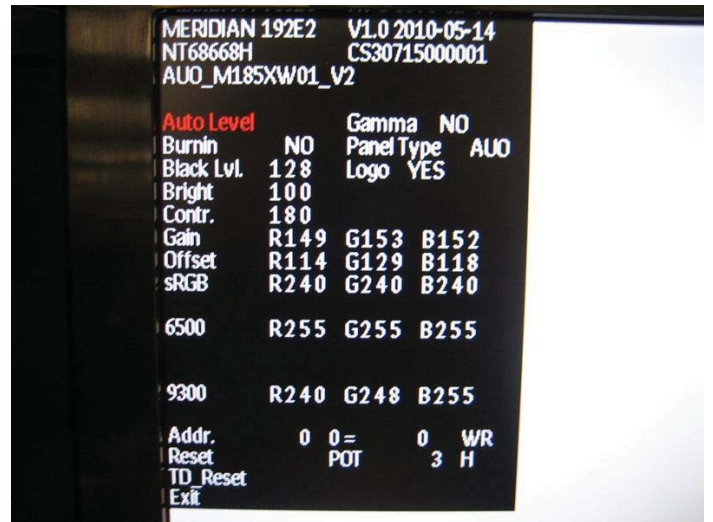

Step 3 : Disconnect interface cable between Monitor and PC.

After 3 seconds, bring up:

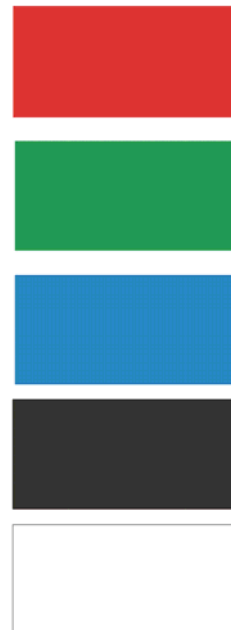

repeatedly

Connect Signal cable again=> go back to normal display

Philips Pixel Defect Policy

Philips' Flat Panel Monitors Pixel Defect Policy

Philips strives to deliver the highest quality products. We use some of the industry's most advanced manufacturing processes and practice stringent quality control. However, pixel or sub pixel defects on the TFT LCD panels used in flat panel monitors are sometimes unavoidable. No manufacturer can guarantee that all panels will be free from pixel defects, but Philips guarantees that any monitor with an unacceptable number of defects will be repaired or replaced under warranty. This notice explains the different types of pixel defects and defines acceptable defect levels for each type. In order to qualify for repair or replacement under warranty, the number of pixel defects on a TFT LCD panel must exceed these acceptable levels. For example, no more than 0.0004% of the sub pixels on a 19" XGA monitor may be defective. Furthermore, Philips sets even higher quality standards for certain types or combinations of pixel defects that are more noticeable than others. This policy is valid worldwide.

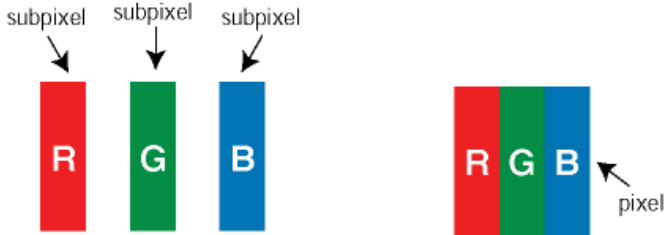

Pixels and Sub pixels

A pixel, or picture element, is composed of three sub pixels in the primary colors of red, green and blue. Many pixels together form an image. When all sub pixels of a pixel are lit, the three colored sub pixels together appear as a single white pixel. When all are dark, the three colored sub pixels together appear as a single black pixel. Other combinations of lit and dark sub pixels appear as single pixels of other colors.

Types of Pixel Defects

Pixel and sub pixel defects appear on the screen in different ways. There are two categories of pixel defects and several types of sub pixel defects within each category.

Bright Dot Defects Bright dot defects appear as pixels or sub pixels that are always lit or 'on'. That is, a *bright dot* is a sub-pixel that stands out on the screen when the monitor displays a dark pattern. There are the types of bright dot defects:



Two adjacent lit sub pixels:

- Red + Blue =

One lit red, green or blue sub pixel

Purple

- Red + Green =

Yellow

- Green + Blue =

Cyan (Light Blue)

Three adjacent lit sub pixels (one white pixel)



A red or blue *bright dot* must be more than 50 percent brighter than neighboring dots while a green bright dot is 30 percent brighter than neighboring dots.

Black Dot Defects Black dot defects appear as pixels or sub pixels that are always dark or 'off'. That is, a *dark dot* is a sub-pixel that stands out on the screen when the monitor displays a light pattern. These are the types of black dot defects:

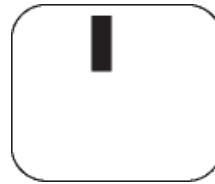

One dark sub pixel

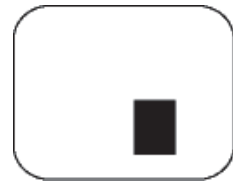

Two or three adjacent dark sub pixels

Proximity of Pixel Defects

Because pixel and sub pixels defects of the same type that are near to one another may be more noticeable, Philips also specifies tolerances for the proximity of pixel defects.

Pixel Defect Tolerances

In order to qualify for repair or replacement due to pixel defects during the warranty period, a TFT LCD panel in a Philips flat panel monitor must have pixel or sub pixel defects exceeding the tolerances listed in the following tables.

BRIGHT DOT DEFECTS	ACCEPTABLE LEVEL
MODEL	192E2
1 lit subpixel	3
2 adjacent lit subpixels	1
3 adjacent lit subpixels (one white pixel)	0
Distance between two bright dot defects*	>15mm
Total bright dot defects of all types	3

BLACK DOT DEFECTS	ACCEPTABLE LEVEL
MODEL	192E2
1 dark subpixel	5 or fewer
2 adjacent dark subpixels	2 or fewer
3 adjacent dark subpixels	0
Distance between two black dot defects*	>15mm
Total black dot defects of all types	5 or fewer

TOTAL DOT DEFECTS	ACCEPTABLE LEVEL
MODEL	192E2
Total bright or black dot defects of all types	5 or fewer

Note:

* 1 or 2 adjacent sub pixel defects = 1 dot defect

Mechanical Instruction

Preparation before disassemble



1.Clean the room for disassemble

2.Identify the area for monitor

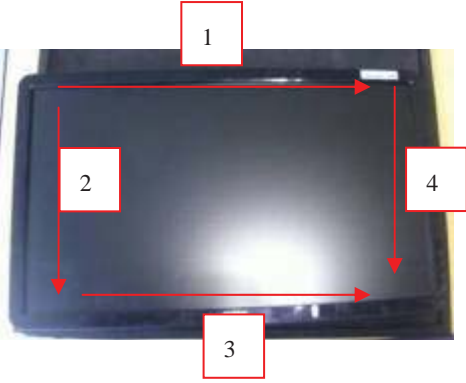

3.Check the position that the monitors be placed and the quantity of the monitor ;prepare the area for material flow; according to the actual condition plan the disassemble layout

4.Prepare the implement, equipments, materials as bellow:

- 1) Press-fixture
- 2) working table
- 3) Screw-driver
- 4) knife*1
- 5) glove
- 6) cleaning cloth
- 7) ESD protection

item	picture	Operation	Tool	Notes
1		Tear off four piece of Mylar Disassemble the stand → 4 screws	Screw-driver	
2		disassembly the bezel from the monitor, notice the disassembly order : 1.Top (1) parts of bezel 2.Left (2) parts of bezel 3.Bottom (3) parts of bezel 4. Right (4) parts of bezel Don't draw the BZL		When disassembly the bezel , notice don't bend the C/B . man must wear glove The purpose is loose the BZL
3		Turn over the monitor , Bring the Rear cover from the monitor		

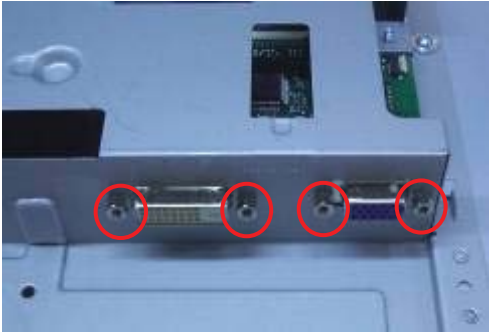

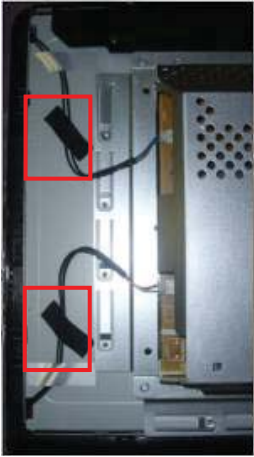
Mechanical Instruction

<p>4</p>		<p>Draw the control board cable</p> <p>Take the entire internal mechanism from Bezel and then put it on the cushion</p>		
<p>5</p>		<p>Disassembled the Main-BKT : hexagonal screw *4</p>	<p>Screw-driver</p>	
<p>6</p>		<p>Tear off al foil on the left of Main-BKT</p>		
<p>7</p>		<p>Tear off the acetic tape</p> <p>Pull out the lamp cables</p>		<p>Notes the below PIC</p> <p>Then the designed Main-BKT will help to pull out the wires</p> <p>Man can raise the Lock of Lamp and then Pull out the lamp easily</p>

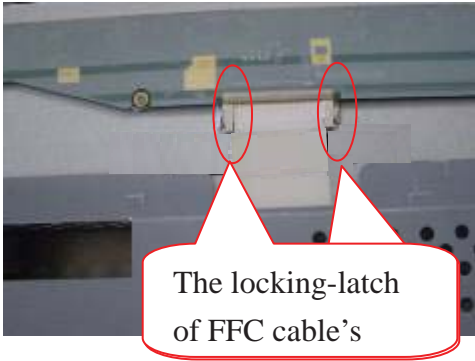
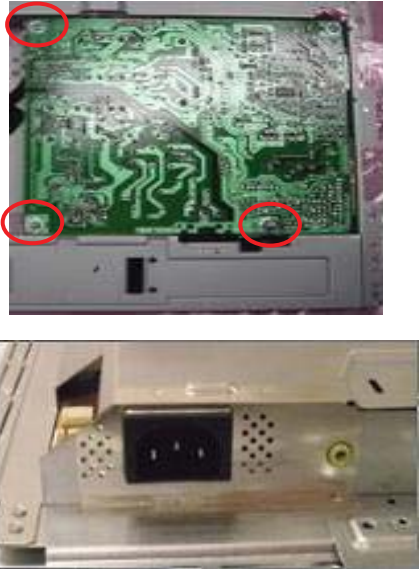
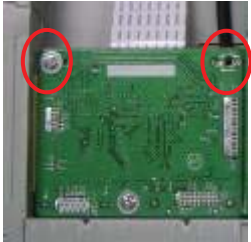
Mechanical Instruction

<p>8</p>		<p>Unlock the FFC by using two hands(see note).</p>		<p>Please carefully use two hands(one hand presses the locking-latch of FFC cable's housing, and at the same time another hand pulls out the FFC cable.) for this step to avoid from deforming the terminals of positive-locking type FFC cable.</p>
<p>9</p>		<p>Tear off the iron sheet which cover the AC-SOCKET Disassemble the Power board → 3 screws</p>	<p>Screw-driver</p>	
<p>10</p>		<p>Disassemble the ITF-board → 2 screws</p>	<p>Screw-driver</p>	

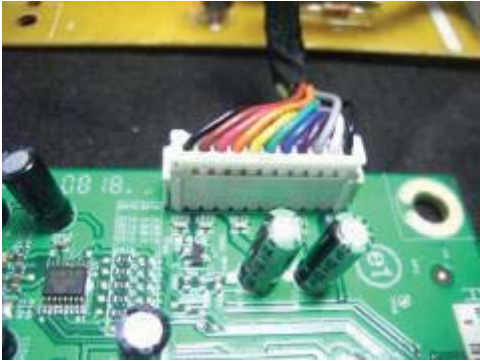
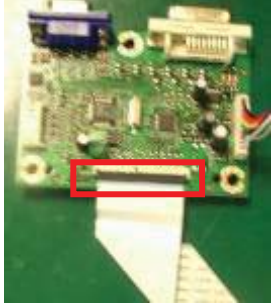
Mechanical Instruction

11		<p>Take the PCBA from Main-BKT and then put it on the cushion</p>		
12		<p>Pull out the cable of Power board</p>		<p>Notes: Pull the connect upright</p>
13		<p>Draw the ffc cable</p>		
14		<p>Take the panel out of the bezel and then tear off a piece of Mylar AL foil on the left</p>		

Color Adjustment

Alignment procedure

1. Turn on the LCD monitor
2. Turn on the Timing/pattern generator. See Fig.1
3. Preset LCD color Analyzer CA-1 10
 - Remove the lens protective cover of probe CA-A30.
 - Set measuring/viewing selector to measuring position for reset analyzer .(zero calibration) as Fig.2
 - Turn on the color analyzer (CA-1 10)
 - Press 0-CAL button to starting reset analyzer .

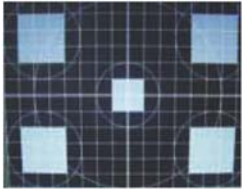

Fig. 1

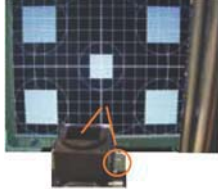

Fig.2

4. Access Factory Mode

- 1). Turn off monitor.
- 2). [Push "AUT O" & "MENU" buttons at the same time and hold them] +[Press "power" button untill comes out "Windows screen"] => then release all buttons
- 3). Press "MENU" button, wait until the OSD menu with Characters " MERIDIAN 192E2 V1.0 2010-05-14" (below OSD menu) come on the Screen of the monitor as shown in Fig3.



Factory Mode indicator

Fig. 3

- 4). Press button, then select factory mode indicator by "MENU" "LEFT" or "RIGHT" button .Press"MENU" button to bring up submenu windows as below:



Fig. 4

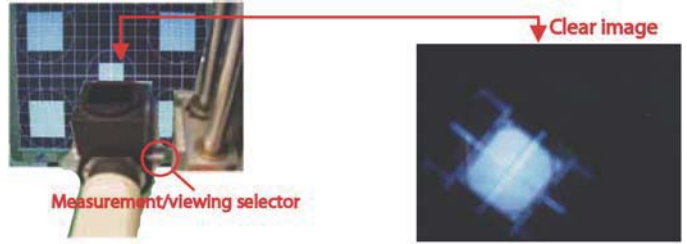

Fig.5

5.Display

Press "UP" or "DOWN" button to select . Change the value by "UP" or "DOWN" key until the X, Y co-ordinates as below

5.1 Color temperature adjustment

There are six factory preset white color 11500K, 9300K, 8200K, 7500K, 6500K, sRGB, 5000K

Align by Philips PerfectTune (also called FGA) function.

Apply full white pattern, with brightness in 100 % position and the contrast control at 50 % position.

The 1931 CIE Chromaticity (color triangle) diagram (x , y) coordinate for the screen center should be:

Product specification

Production alignment spec.

	x = 0.283 ± 0.02	9300K	x = 0.283 ± 0.006
9300K	y = 0.297 ± 0.02	6500K/sRGB	y = 0.297 ± 0.006
6500K/sRGB	x = 0.313 ± 0.02		x = 0.313 ± 0.006
	y = 0.329 ± 0.02		y = 0.329 ± 0.006
	x = 0.313 ± 0.02	sRGB	x = 0.313 ± 0.006
sRGB	y = 0.329 ± 0.02	9300K	y = 0.329 ± 0.006
9300K	x = 0.283 ± 0.02		x = 0.283 ± 0.006
	y = 0.297 ± 0.02		y = 0.297 ± 0.006
	x = 0.313 ± 0.02	6500K/sRGB	x = 0.313 ± 0.006
6500K/sRGB	y = 0.329 ± 0.02	sRGB	y = 0.329 ± 0.006
sRGB	x = 0.313 ± 0.02		x = 0.313 ± 0.006
	y = 0.329 ± 0.02		y = 0.329 ± 0.006

Quality Inspection specification:

9300K	x = 0.283 ± 0.015
6500K/sRGB	y = 0.297 ± 0.015
	x = 0.313 ± 0.015
	y = 0.329 ± 0.015
sRGB	x = 0.313 ± 0.015
9300K	y = 0.329 ± 0.015
	x = 0.283 ± 0.015
	y = 0.297 ± 0.015
6500K/sRGB	x = 0.313 ± 0.015
sRGB	y = 0.329 ± 0.015
	x = 0.313 ± 0.015
	y = 0.329 ± 0.015

FAQs (Frequently Asked Questions)

Q1: When I install my monitor what should I do if the screen shows 'Cannot display this video mode'?

Ans.: Recommended resolution for Philips 21.5": 1920x1080 @60Hz.

- Unplug all cables, then connect your PC to the monitor that you used previously.
- In the Windows Start Menu, select Settings/ Control Panel. In the Control Panel Window, select the Display icon. Inside the Display Control Panel, select the 'Settings' tab. Under the setting tab, in box labeled 'desktop area', move the sidebar to 1920x1080 pixels (21.5").
- Open 'Advanced Properties' and set the Refresh Rate to 60Hz, then click OK.
- Restart your computer and repeat step 2 and 3 to verify that your PC is set at 1920x1080@60Hz (21.5").
- Shut down your computer, disconnect your old monitor and reconnect your Philips LCD monitor.
- Turn on your monitor and then turn on your PC.

Q2: What does the recommended refresh rate for LCD monitor?

Ans.: Recommended refresh rate in LCD monitors is 60Hz, In case of any disturbance on screen, you can set it up to 75Hz to see if that removes the disturbance.

Q3: What are the .inf and .icm files on the CD-ROM? How do I install the drivers (.inf and .icm)?

Ans.: These are the driver files for your monitor. Follow the instructions in your user manual to install the drivers. Your computer may ask you for monitor drivers (.inf and .icm files) or a driver disk when you first install your monitor. Follow the instructions to insert the (companion CD-ROM) included in this package. Monitor drivers (.inf and .icm files) will be installed automatically.

Q4: How do I adjust the resolution?

Ans.: Your video card/graphic driver and monitor together determine the available resolutions. You can select the desired resolution under Windows® Control Panel with the "Display properties".

Q5: What if I get lost when I am making monitor adjustments via OSD?

Ans.: Simply press the OK button, then select 'Reset' to recall all of the original factory settings.

Q6: Is the LCD screen resistant to scratches?

Ans.: In general it is recommended that the panel surface is not subjected to excessive shocks and is protected from sharp or blunt objects. When handling the monitor, make sure that there is no pressure or force applied to the panel surface side. This may affect your warranty conditions.

FAQs (Frequently Asked Questions)

Q7: How should I clean the LCD surface?

Ans.: For normal cleaning, use a clean, soft cloth. For extensive cleaning, please use isopropyl alcohol. Do not use other solvents such as ethyl alcohol, ethanol, acetone, hexane, etc.

Q8: Can I change the color setting of my monitor?

Ans.: Yes, you can change your color setting through OSD control as the following procedures,

- Press "OK" to show the OSD (On Screen Display) menu
- Press "Down Arrow" to select the option "Color" then press "OK" to enter color setting, there are three settings as below.
 1. Color Temperature; The 2 settings are 6500K, and 9300K.
 2. sRGB; this is a standard setting for ensuring correct exchange of colors between different device (e.g. digital cameras, monitors, printers, scanners, etc)
 3. User Define; the user can choose his/her preference color setting by adjusting red, green blue color.

Note:

A measurement of the color of light radiated by an object while it is being heated. This measurement is expressed in terms of absolute scale, (degrees Kelvin). Lower Kelvin temperatures such as 2004K are red; higher temperatures such as 9300K are blue. Neutral temperature is white, at 6504K.

Q9: Can the Philips LCD Monitor be mounted on the wall?

Ans.: Yes. Philips LCD monitors have this optional feature. Four standard VESA mount holes on the rear cover allows the user to mount the Philips monitor on most of the VESA standard arms or accessories. We recommend you to contact your Philips sales representative for more information.

Q10: Can I connect my LCD monitor to any PC, workstation or Mac?

Ans.: Yes. All Philips LCD monitors are fully compatible with standard PCs, Macs and workstations. You may need a cable adapter to connect the monitor to your Mac system. Please contact your Philips sales representative for more information.

Q11: Are Philips LCD monitors Plug-and- Play?

Ans.: Yes, the monitors are Plug-and-Play compatible with Windows 7/Vista/XP/NT, Mac OSX, Linux

Q12: What kind of wide-angle technology is available?

Ans.: Currently, the IPS type panels offer the best Contrast Ratio, compared to MVA, or PVA technologies. TN panels have improved over the years, but IPS panel still gives superior results over TN panel.

Electrical Instructions

Electrical characteristics

1. Interface signals

1.1 D-Sub Analog

- Input signal: Video, Hsync., Vsync
- Video: 0.7 Vp-p, input impedance, 75 ohm @DC
- Sync.: Separate sync TTL level, input impedance 2.2k ohm terminate
- Hsync Positive/Negative
- Vsync Positive/Negative
- Composite sync TTL level, input impedance 2.2k ohm terminate
- Sync on green video 0.3 Vp-p Negative (Video 0.7 Vp-p Positive)

1.2 DVI-D Digital

Input signal: Single TMDS link (Three channels: RX0-/, RX1-/, RX2-/)

2. Interface

2.1 D-Sub Cable

- Length : 1.8 M +/- 50 mm
- Fix with monitor when packing, with transplant pin protective cover.
- Connector type : D-Sub male with DDC2B pin assignments.
- Blue connector thumb-operated jack screws

2.2 DVI Cable

- The input signals are applied to the display through DVI-D cable.
- Length : 1.8 M +/- 50 mm
- Connector type : DVI-D male with DDC-2B pin assignments
- White connector thumb-operated jackscrews
- With transplant pin protective cover.

3. Timing requirement

3.1 Factory Preset mode definition:

- 3.1.1 Perfect FOS while presenting those timings.
- 3.1.2 Will specify those timing in User's Manual

3.2 Preset mode definition:

- 3.2.1 Need to support those timings.
- 3.2.2 Perfect FOS after auto adjustment.

3.3 User mode

- 3.3.1 Can save those timing that not in Preset mode and can be showed (not over scalar or Panel spec.)
- 3.3.2 It needs to reserve the 10 timings space in memory size.
- 3.3.3 Factory modes and preset modes are defined in the enclosed timing table file

Support Timing	Factory Preset Timing	Resolution	Pixel Rate (MHz)	Horizontal (KHz)	Vertical (Hz)	V_Total (Line)	Polarity (H/V)
*	-	DOS	640x350/70	25.18	31.47	70.09	449 p/n
*	-	DOS	720x400/70	28.32	31.47	70.09	449 n/p
*	*	DMT	4:3 640x480/60	28.18	31.47	59.94	525 n/n
*	*	DMT	4:3 640x480/67	30.24	35.00	66.67	525 n/n
*	*	DMT	4:3 640x480/72	31.50	37.86	72.81	520 n/n
*	*	DMT	4:3 640x480/75	31.50	37.50	75.00	500 n/n
*	*	DMT	4:3 640x480/85	36.00	43.27	85.00	500 n/n
*	*	DMT	4:3 800x600/56	36.00	35.16	56.25	625 p/p
*	*	DMT	4:3 800x600/60	40.00	37.88	60.32	628 p/p
*	*	DMT	4:3 800x600/72	50.00	48.08	72.19	656 p/p
*	*	DMT	4:3 800x600/75	49.50	46.88	75.00	625 p/p
*	*	DMT	4:3 800x600/85	56.25	54.14	85.00	631 p/p
*	*	MAC	832x624/75	57.28	47.73	74.55	667 n/n
*	*	DMT	4:3 1024x768/60	65.00	48.36	60.00	806 n/n
*	*	DMT	4:3 1024x768/70	75.00	56.48	70.07	806 n/n
*	*	DMT	4:3 1024x768/75	78.75	60.02	75.03	800 p/p
*	*	DMT	4:3 1152x864/60	83.25	63.25	60.00	900 p/p
*	*	DMT	4:3 1152x864/70	94.50	63.90	70.00	912 p/p
*	*	DMT	4:3 1152x864/75	108.00	67.50	75.00	900 p/p
*	*	MAC	1152x870/75	100.00	68.68	75.06	915 n/n
*	*	SUN	1152x900/66	92.94	61.80	65.95	937 p/p
*	*	SUN	1280x720/60	74.50	44.77	59.86	748 n/p
*	*	CVT	16:9 1280x720/75	95.75	56.46	74.78	755 n/p
*	*	CVT	4:3 1280x720/85	110.25	64.40	84.85	758 p/p
*	*	CVT	15:9 1280x768/60	79.50	47.78	59.87	798 n/p
*	*	CVT	15:9 1280x768/75	102.25	60.29	74.89	805 n/p
*	*	CVT	15:9 1280x800/60	83.50	49.70	59.81	831 p/p
*	*	CVT	1280x800/75	106.50	62.80	74.93	838 n/p
*	*	CVT	4:3 1280x800/85	122.50	71.65	84.88	843 p/p
*	*	DMT	4:3 1280x960/60	108.00	60.00	60.00	1000 p/p
*	*	CVT	4:3 1280x960/75	130.00	75.23	74.86	1005 n/p
*	*	DMT	4:3 1280x960/85	148.50	85.04	85.00	1011 p/p
*	*	DMT	5:4 1280x1024/60	108.00	63.88	60.02	1066 p/p
*	*	SUN	5:4 1280x1024/66	117.00	71.70	67.00	1067 p/p
*	*	DOS	5:4 1280x1024/72	130.22	76.00	72.00	1064 p/p
*	*	DMT	5:4 1280x1024/75	135.00	79.98	75.03	1066 p/p
*	*	SUN	5:4 1280x1024/76	138.01	81.10	75.00	1066 n/n
*	*	DMT	5:4 1280x1024/85	157.50	91.18	85.00	1072 p/p
*	*	DMT	16:9 1360x768/60	85.50	47.71	60.02	795 p/p
*	*	DMT	16:9 1360x768/75	109.00	60.29	74.89	805 n/p
*	*	CVT	16:9 1360x768/60	85.50	47.71	59.79	798 p/p
*	*	CVT	1440x900/60_RB	88.75	55.47	59.90	926 n/p
*	*	CVT	1440x900/60	106.50	55.94	59.89	934 n/p
*	*	CVT	1440x900/75	136.75	70.64	74.98	942 n/p
*	*	CVT	1440x900/85	157.00	80.13	84.84	948 p/p
*	*	DMT	1600x1000/60	160.00	75.00	60.00	1250 p/p
*	*	CVT	16:10 1680x1050/60_RB	119.00	64.67	59.88	1080 p/n
*	*	CVT	16:10 1680x1050/60	146.25	65.29	59.95	1089 n/p
*	*	CVT	16:9 1920x1080/60_RB	138.50	66.59	59.93	1111 p/n
*	*	CVT	16:10 1920x1200/60_RB	154.00	74.04	59.95	1235 p/n

Electrical Instructions

White color adjustment

There are three factory preset white color 9300K, 6500K, sRGB.

Apply full gray64 pattern, with brightness in 100 % position and the contrast control at 50 % position. The 1931 CIE Chromaticity (color triangle) diagram (x ,y) coordinate for the screencenter should be:

Product specification

CIE coordinates	(x,y)	
9300K	x = 0.283 ± 0.02 y = 0.297 ± 0.02	Perfectunell
6500K/sRGB	x = 0.313 ± 0.02 y = 0.329 ± 0.02	Perfectunell
sRGB	x = 0.313 ± 0.02 y = 0.329 ± 0.02	Perfectunell

Production alignment spec.

CIE coordinates	(x,y)	
9300K	x = 0.283 ± 0.006 y = 0.297 ± 0.006	Perfectunell
6500K/sRGB	x = 0.313 ± 0.006 y = 0.329 ± 0.006	Perfectunell
sRGB	x = 0.313 ± 0.006 y = 0.329 ± 0.006	Perfectunell

Quality Inspection specification:

CIE coordinates	(x,y)	
9300K	x = 0.283 ± 0.015 y = 0.297 ± 0.015	
6500K/sRGB	x = 0.313 ± 0.015 y = 0.329 ± 0.015	
sRGB	x = 0.313 ± 0.015 y = 0.329 ± 0.015	

Service tool-Hardware

PCM code	12NC
5E.L8215.001	996510019769

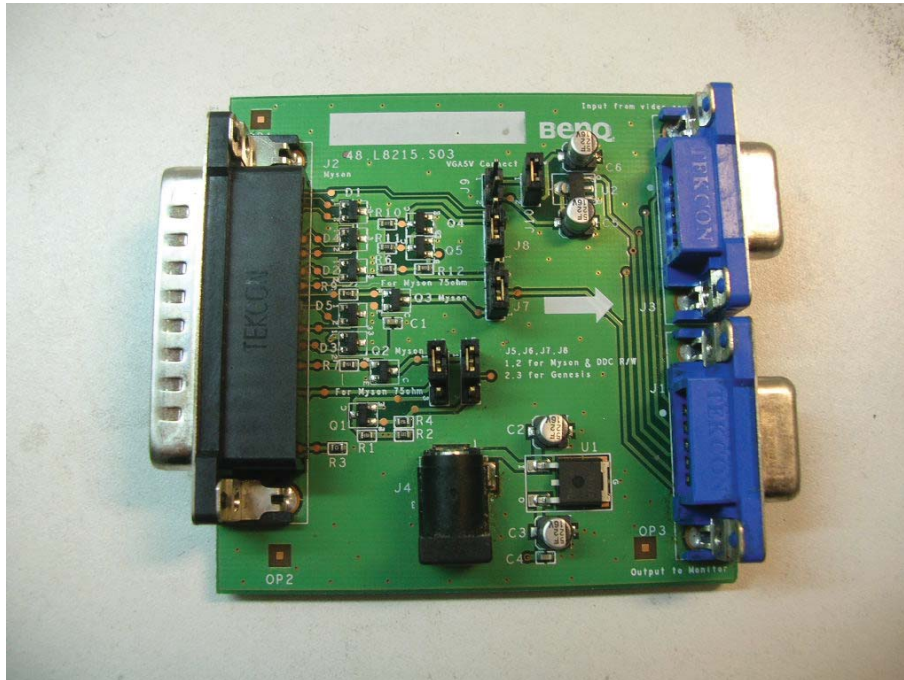

DDC Instructions

DDC Data Re-programming

In case the DDC data memory IC or main EEPROM which storage all factory settings were replaced due to a defect, the serial numbers have to be re-programmed "Analog DDC IC, Digital DDC IC & EEPROM".

It is advised to re-soldered DDC IC and main EEPROM from the old board onto the new board if circuit board have been replaced, in this case the DDC data does not need to be re-programmed.

Additional information

Additional information about DDC (Display Data Channel) may be obtained from Video Electronics Standards Association (VESA).

Extended Display Identification Data(EDID) information may be also obtained from VESA.

Configuration and procedure

"PI-EDID" The software is provided by IMS to upgrade the firmware of CPU.

PI-EDID Tools is for the interface between "Parallel Port of PC" and "15 pin-D-SUB connector of Monitor".

It is a windows-based program, which cannot be run in MS-DOS.

System and equipment requirements

1. An Pentium (or above) personal computer or compatible.
2. Microsoft operation system Windows 95/98/2000/XP and Port95NT.exe.
3. EDID Software "PI-EDID.exe"
4. ISP boardas shown in Fig. 1

And I2C Board Jump wire should follow J10 (short), J9 (open), J5/J6/ (1and 2 pin short) J7/J8 (1 and 2 pin short)

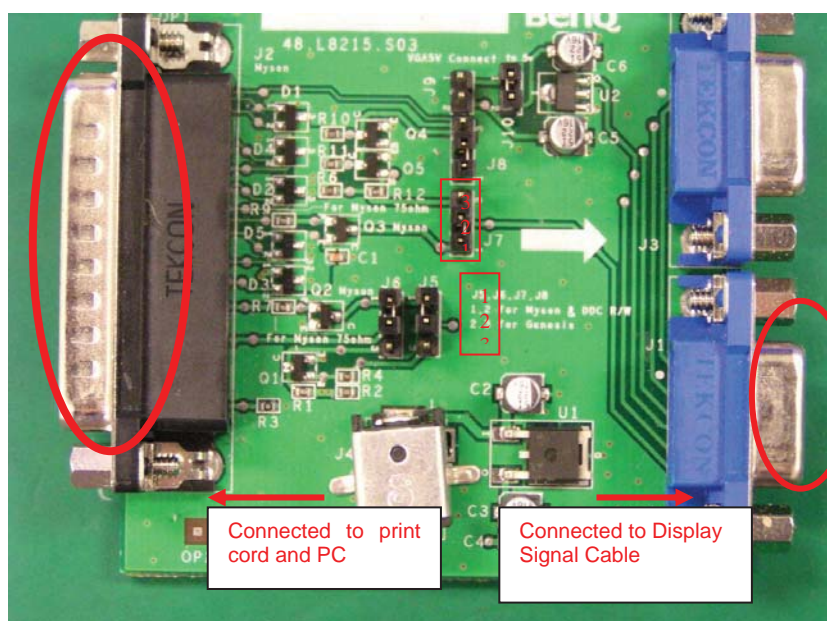

Fig.1

DDC Instructions

5. Connect and Mains cord to Monitor as shown in Fig.2.

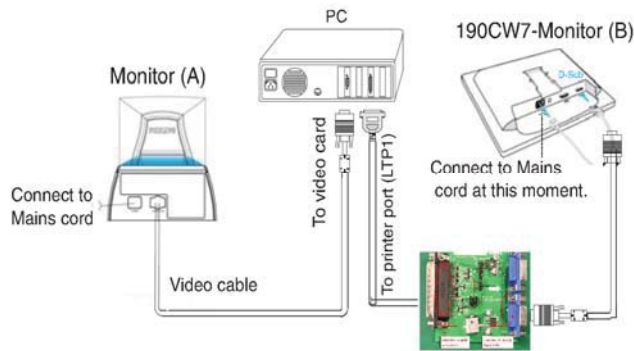
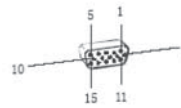

Fig.2

Pin assignments :

A. 15-pin D-Sub Connector



PIN No.	SIGNAL	PIN No.	SIGNAL
1	Red	9	DDC +3.3V or +5V
2	Green/ SOG	10	Logic GND
3	Blue	11	Sense (GND)
4	Sense (GND)	12	Bi-directional data
5	Cable Detect (GND)	13	H/H+V sync
6	Red GND	14	V-sync
7	Green GND	15	Data clock
8	Blue GND		

B. Input DVI-D Connector pin

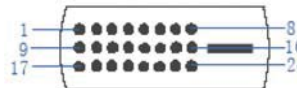

Pin No.	Description
1	T.M.D.S. data2-
2	T.M.D.S. data2+
3	T.M.D.S. data2 shield
4	No Connect
5	No Connect
6	DDC clock
7	DDC data
8	No Connect
9	T.M.D.S. data1-
10	T.M.D.S. data1+
11	T.M.D.S. data1 shield
12	No Connect
13	No Connect
14	+5V Power
15	Ground (for +5V)
16	Hot plug detect
17	T.M.D.S. data0-
18	T.M.D.S. data0+
19	T.M.D.S. data0 shield
20	No Connect
21	No Connect
22	T.M.D.S clock shield
23	T.M.D.S. clock+
24	T.M.D.S. clock-

DDC Instructions

6. Setup the Philips-IMS EDID Tools program

Step 1: Open Q-EDID Software into your folder as shown in Fig.3. and Fig.4.



Fig.3

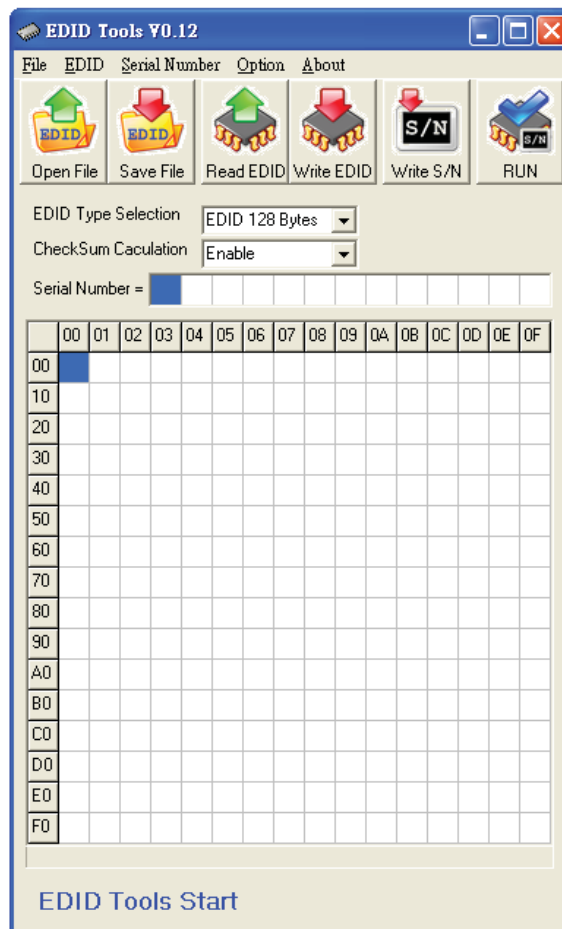

Fig.4

DDC Instructions

Step 2: Press “Open File” then choose LCD_Analog.ddc or LCD_DVI.ddc as shown in Fig. 5 .

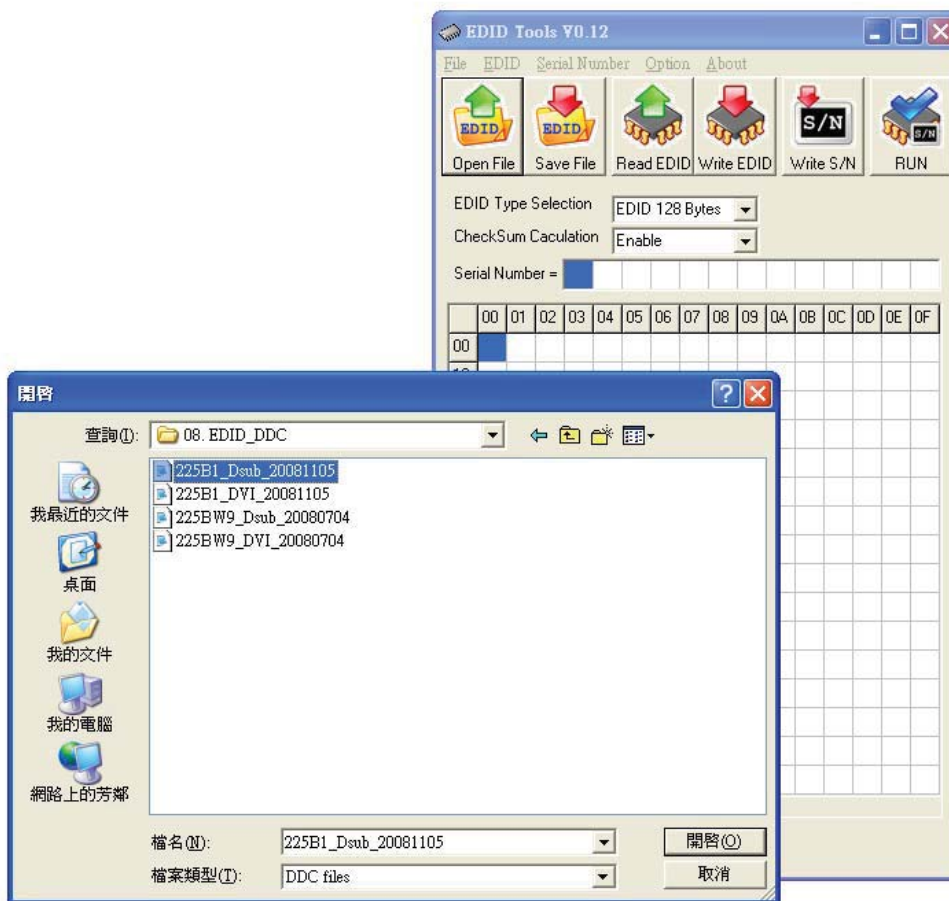

Fig.5

DDC Instructions

Step 3 : Load DDC file success as shown in Fig. 6 .

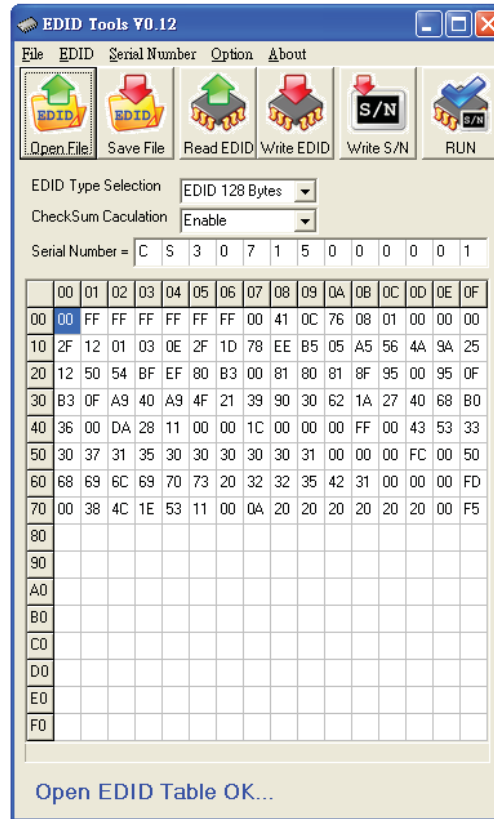

Fig.6

Step 4 : update Serial number and press enter to correct S/N number shown as Fig.7 .

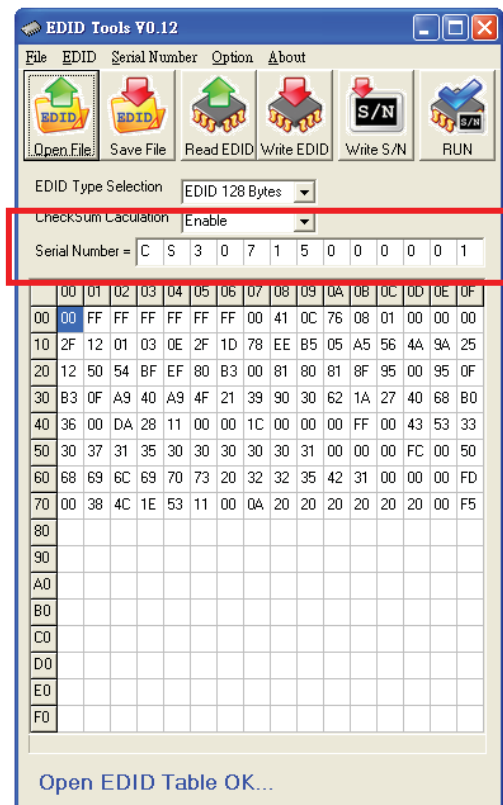

Fig.7

DDC Instructions

Step 5 : Press “RUN” to write EDID and serial number shown as Fig.8 .

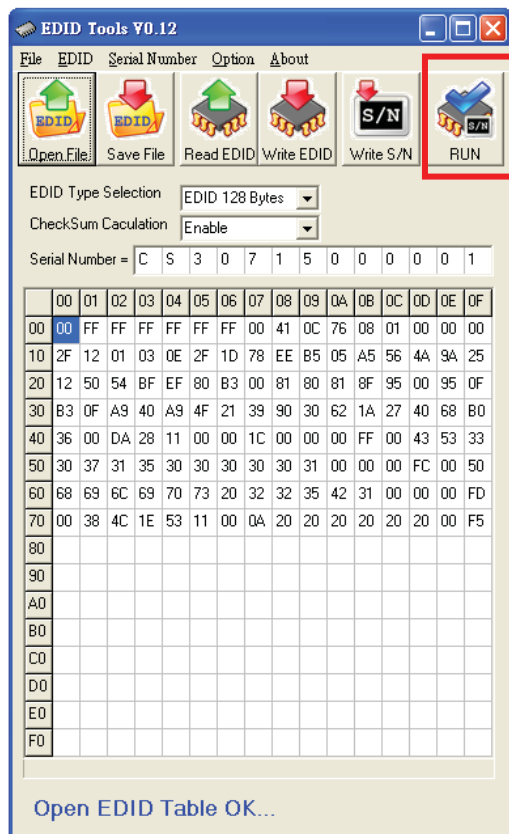

Fig.8

Step 6 : EDID and serial number update success shown as Fig.9

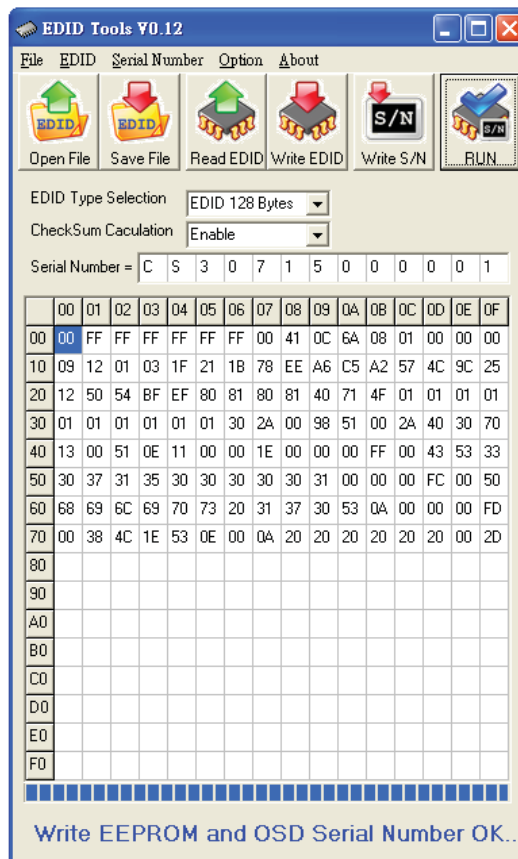

Fig.9

DDC Instructions

- Press Monitor Menu Key to check OSD Serial number is the same as PI-EDID write data as shown in Fig.10

Note: If not the same, please rewrite EDID S/N again.

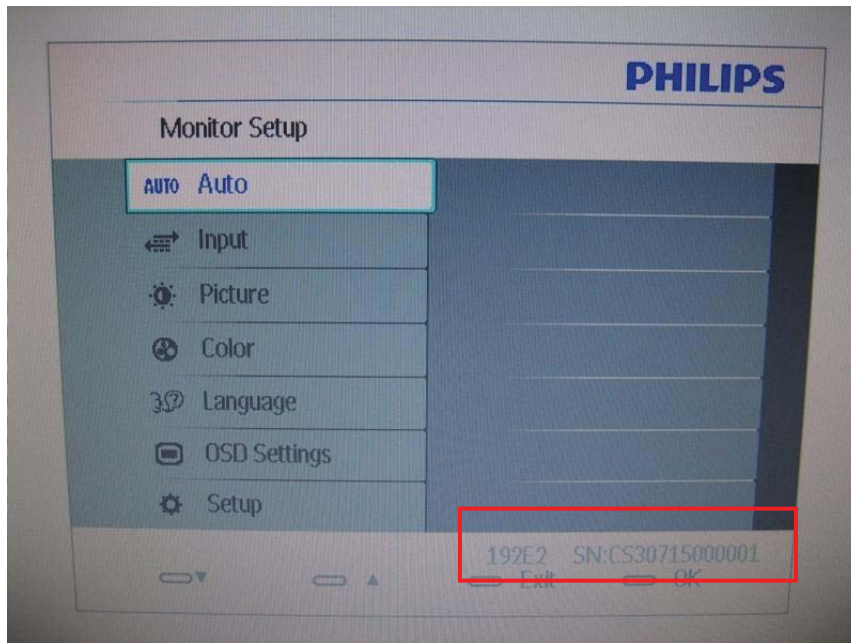

Fig.14

- Turn off the monitor, exit the factory mode.

Serial Number Definition

PANEL TYPE

1: AUO	2: CPT
3: LGD(LPL)	4: SEC
5: CMO	6: HanStar
7: SVA	8: BOE
9: MTD	

FACTORY CODE:

H=QTY
X=QMX
T=QCS
Z=QZB
S=QCOS

SSPAYYWWXXXXXX

F

Site code
DL: Suzhou
CS: Taiwan
FE: Czech

Week



Sequence number 000001~999999
(Please reset and start from 00001,
when hit the limit 99999)

Service Version

Year: 2010
2011

DDC DATA

Analog DDC

```
/////////Displaying Monitor EDID/////////
```

128 bytes EDID Data (Hex):

```
0  1  2  3  4  5  6  7  8  9
00,FF,FF,FF,FF,FF,FF,00,41,0C,4E,C0,01,00,00,00,0B,14,
01,03,6E,29,17,78,EE,EE,95,A3,54,4C,99,26,
.....
0F,50,54,BF,EF,80,61,40,61,4F,81,80,81,8F,01,01,01,01,0
1,01,01,01,66,21,56,AA,51,00,1E,30,46,8F,
.....
33,00,9A,E6,10,00,00,1E,00,00,00,FF,00,43,53,33,30,37,
31,35,30,30,30,30,30,31,00,00,00,FC,00,50,
.....
68,69,6C,69,70,73,20,31,39,32,45,4C,00,00,00,FD,00,38,
4C,1E,53,0E,00,0A,20,20,20,20,20,20,00,25
```

Decoded EDID data

```
Model name..... Philips 192E
Manufacturer..... Philips
Plug and Play ID..... PHLC04D
Serial number..... CS30715000001
Manufacture date..... 2010, ISO week 11
-----
EDID revision..... 1.3
Input signal type..... Analog 0.700,0.000 (0.7V p-p)
Sync input support.  Separate, Composite,
    Sync-on-green
Display type..... RGB color
Screen size..... 410 x 230 mm (18.5 in)
Power management..... Standby, Suspend, Active
    off/sleep
Extension blocs..... None
-----
DDC/CI..... Supported
MCCS revision..... 2.1
Display technology..... TFT
Controller..... Novatek 0x0
Firmware revision..... 0.112
Active power on time..... 43 hours
Current frequency..... 47.70kHz, 59.80Hz
```

Color characteristics

```
Default color space..... sRGB
Display gamma..... 2.20
Red chromaticity..... Rx 0.640 - Ry 0.330
Green chromaticity..... Gx 0.300 - Gy 0.600
Blue chromaticity..... Bx 0.150 - By 0.060
White point (default).... Wx 0.313 - Wy 0.329
Additional descriptors... None
```

Timing characteristics

```
Horizontal scan range.... 30-83kHz
Vertical scan range..... 56-76Hz
Video bandwidth..... 140MHz
CVT standard..... Not supported
GTF standard..... Not supported
Additional descriptors... None
```

```
Preferred timing..... Yes
Native/preferred timing.. 1366x768p at 60Hz (16:9)
Modeline..... "1366x768" 85.500 1366 1436
1579 1792 768 771 774 798 +hsync +vsync
```

Standard timings supported

```
720 x 400p at 70Hz - IBM VGA
640 x 480p at 60Hz - IBM VGA
640 x 480p at 67Hz - Apple Mac II
640 x 480p at 72Hz - VESA
640 x 480p at 75Hz - VESA
800 x 600p at 56Hz - VESA
800 x 600p at 60Hz - VESA
800 x 600p at 72Hz - VESA
800 x 600p at 75Hz - VESA
832 x 624p at 75Hz - Apple Mac II
1024 x 768p at 60Hz - VESA
1024 x 768p at 70Hz - VESA
1024 x 768p at 75Hz - VESA
1280 x 1024p at 75Hz - VESA
1152 x 870p at 75Hz - Apple Mac II
1024 x 768p at 60Hz - VESA STD
1024 x 768p at 75Hz - VESA STD
1280 x 1024p at 60Hz - VESA STD
1280 x 1024p at 75Hz - VESA STD
```

DDC DATA

DVI DDC

/////////Displaying Monitor EDID/////////

1579 1792 768 771 774 798 +hsync +vsync

128 bytes EDID Data (Hex):

```

0  1  2  3  4  5  6  7  8  9
00,FF,FF,FF,FF,FF,FF,00,41,0C,4E,C0,01,00,00,00,0B,14,
01,03,80,29,17,78,EE,EE,95,A3,54,4C,99,26,
.....
0F,50,54,BF,EF,80,61,40,61,4F,81,80,81,8F,01,01,01,01,0
1,01,01,01,66,21,56,AA,51,00,1E,30,46,8F,
.....
33,00,9A,E6,10,00,00,1E,00,00,00,FF,00,43,53,33,30,37,
31,35,30,30,30,30,30,31,00,00,00,FC,00,50,
.....
68,69,6C,69,70,73,20,31,39,32,45,4C,00,00,00,FD,00,38,
4C,1E,53,0E,00,0A,20,20,20,20,20,20,00,13

```

Monitor #1 [Real-time 0x0011]

```

Model name..... Philips 192E
Manufacturer..... Philips
Plug and Play ID..... PHLC04D
Serial number..... CS30715000001
Manufacture date..... 2010, ISO week 11
-----
EDID revision..... 1.3
Input signal type..... Digital
Color bit depth..... Undefined
Display type..... RGB color
Screen size..... 410 x 230 mm (18.5 in)
Power management..... Standby, Suspend, Active
off/sleep
Extension blocs..... None
-----
DDC/CI..... Supported
MCCS revision..... 2.1
Display technology..... TFT
Controller..... Novatek 0x0
Firmware revision..... 0.112
Active power on time..... 43 hours
Current frequency..... 47.70kHz, 59.80Hz

```

Color characteristics

```

Default color space..... sRGB
Display gamma..... 2.20
Red chromaticity..... Rx 0.640 - Ry 0.330
Green chromaticity..... Gx 0.300 - Gy 0.600
Blue chromaticity..... Bx 0.150 - By 0.060
White point (default).... Wx 0.313 - Wy 0.329
Additional descriptors... None

```

Timing characteristics

```

Horizontal scan range.... 30-83kHz
Vertical scan range..... 56-76Hz
Video bandwidth..... 140MHz
CVT standard..... Not supported
GTF standard..... Not supported
Additional descriptors... None
Preferred timing..... Yes
Native/preferred timing.. 1366x768p at 60Hz (16:9)
Modeline..... "1366x768" 85.500 1366 1436

```

Standard timings supported

```

720 x 400p at 70Hz - IBM VGA
640 x 480p at 60Hz - IBM VGA
640 x 480p at 67Hz - Apple Mac II
640 x 480p at 72Hz - VESA
640 x 480p at 75Hz - VESA
800 x 600p at 56Hz - VESA
800 x 600p at 60Hz - VESA
800 x 600p at 72Hz - VESA
800 x 600p at 75Hz - VESA
832 x 624p at 75Hz - Apple Mac II
1024 x 768p at 60Hz - VESA
1024 x 768p at 70Hz - VESA
1024 x 768p at 75Hz - VESA
1280 x 1024p at 75Hz - VESA
1152 x 870p at 75Hz - Apple Mac II
1024 x 768p at 60Hz - VESA STD
1024 x 768p at 75Hz - VESA STD
1280 x 1024p at 60Hz - VESA STD
1280 x 1024p at 75Hz - VESA STD

```

Firmware Upgrade for CPU

1. Hardware Requirement:

- 1.1. I2C board x 1 (a.Print Board b. I2C Board)
- 1.2. DSUB VGA cables x 2
- 1.3. Printer cable (with one male connector and another female connector) x 1.
- 1.4. PC or Notebook with parallel (printer) port x1.

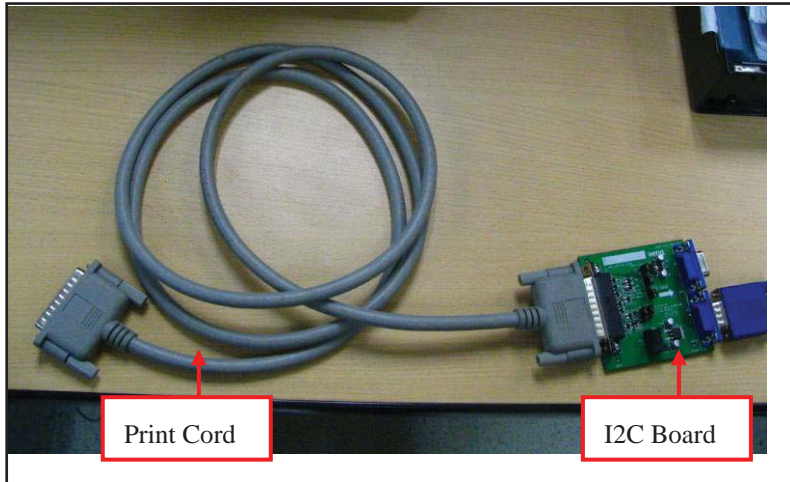

- 1.5 Check the Jumpers on the I2C circuit board (make sure J5/J6/J7/J8 are set at Pin 1 & Pin 2 short)

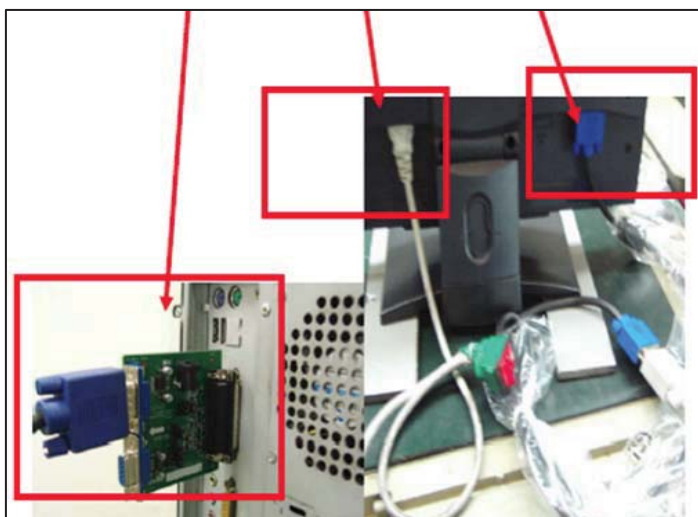
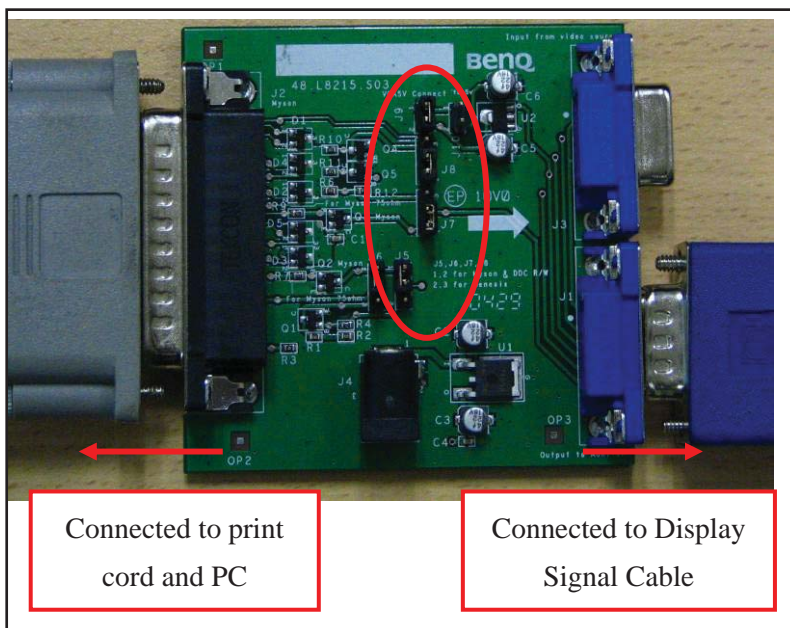

Firmware Upgrade for CPU

2. Software prepare

Step 1: Install Port95nt.exe. Re-star computer

Step 2: Double click NOVATEK Tool

Option:

1. Choose "MYSON"
2. IIC Speed: 1000
3. Press confirm change

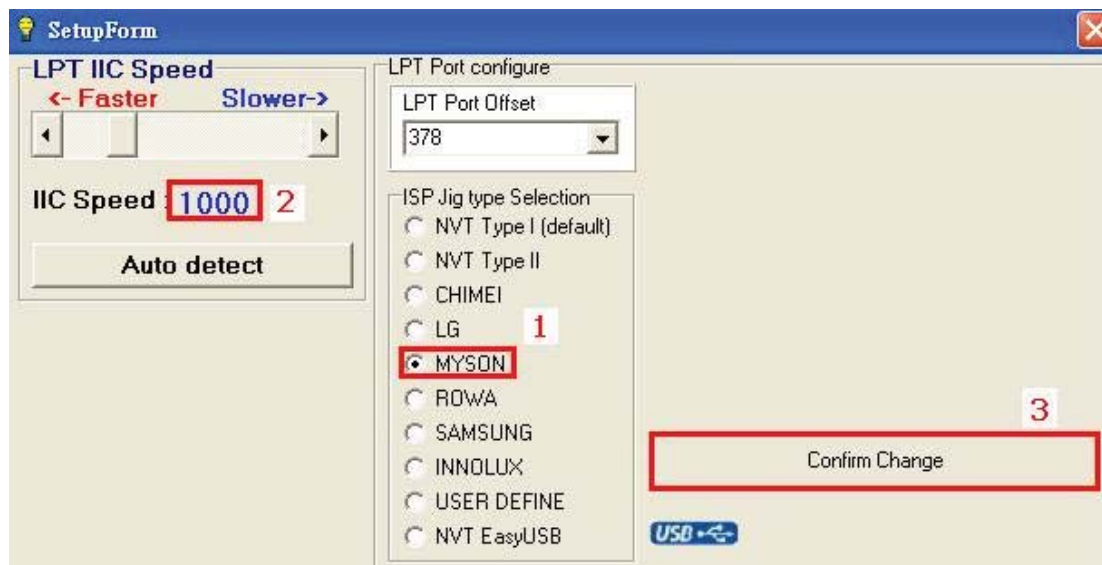

Step 3: Press Load File and choose *.hex

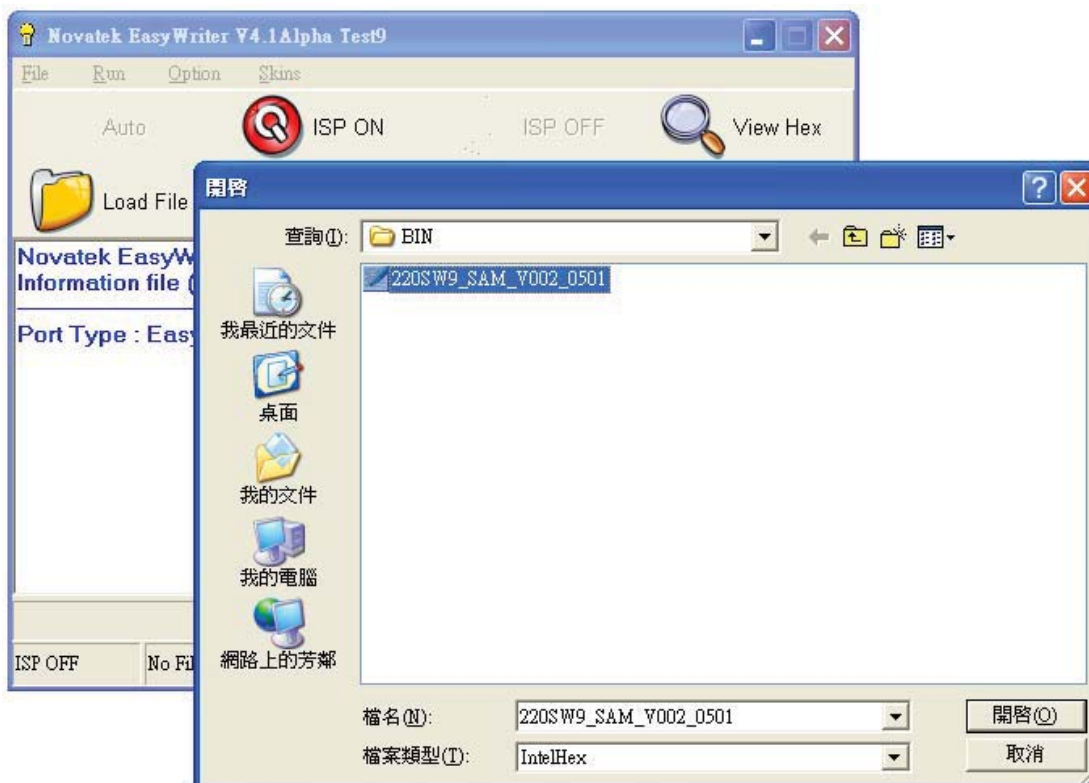

Firmware Upgrade for CPU

Step 4: Press "Auto" to upgrade FW



Firmware Upgrade for CPU

Step 5: Upgrade OK

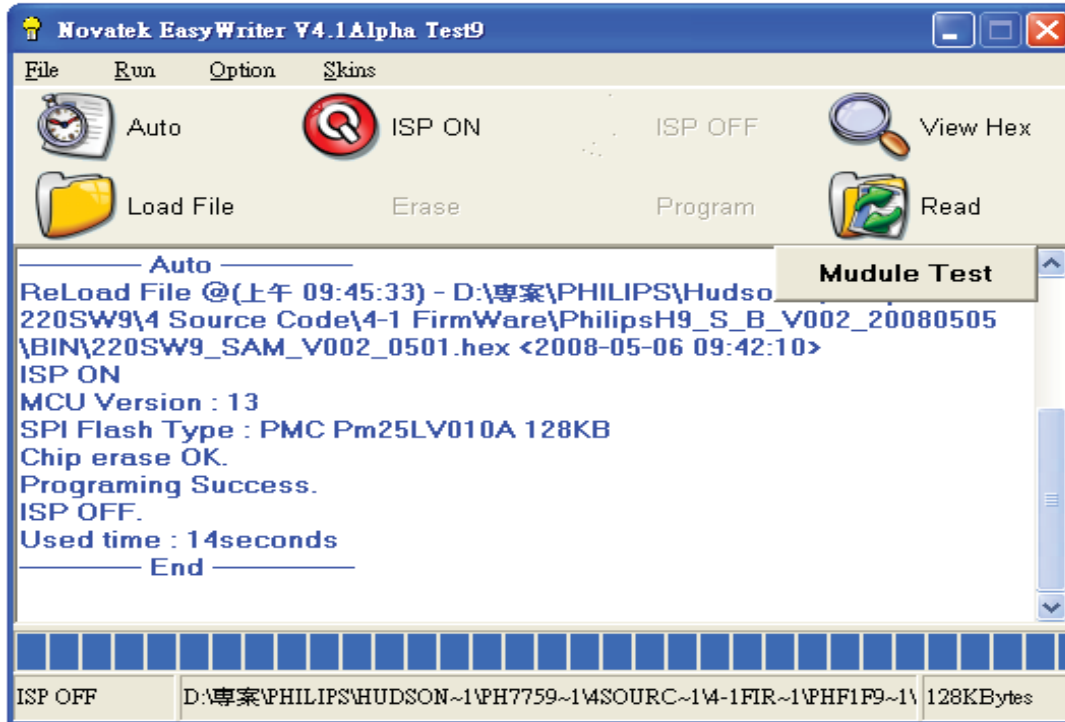

Failure Mode Of Panel

Quick reference for failure mode of LCD panel

this page presents problems that could be made by LCD panel. It is not necessary to repair circuit board. Simply follow the mechanical instruction on this manual to eliminate failure by replace LCD panel.

Failure description

Phenomenon

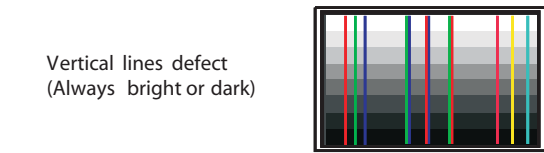
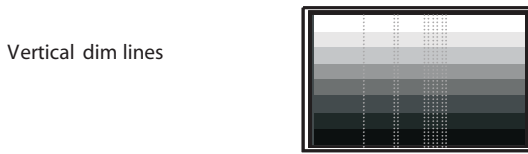

Polarizer has bubbles



Polarizer has bubbles



Foreign material inside polarizer. It shows liner or dot shape.



Concentric circle formed



Bottom back light of LCD is brighter than normal

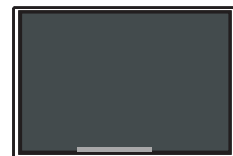

Back light un-uniformity



Backlight has foreign material. Black or white color, liner or circular type



Wiring Diagram

192E2

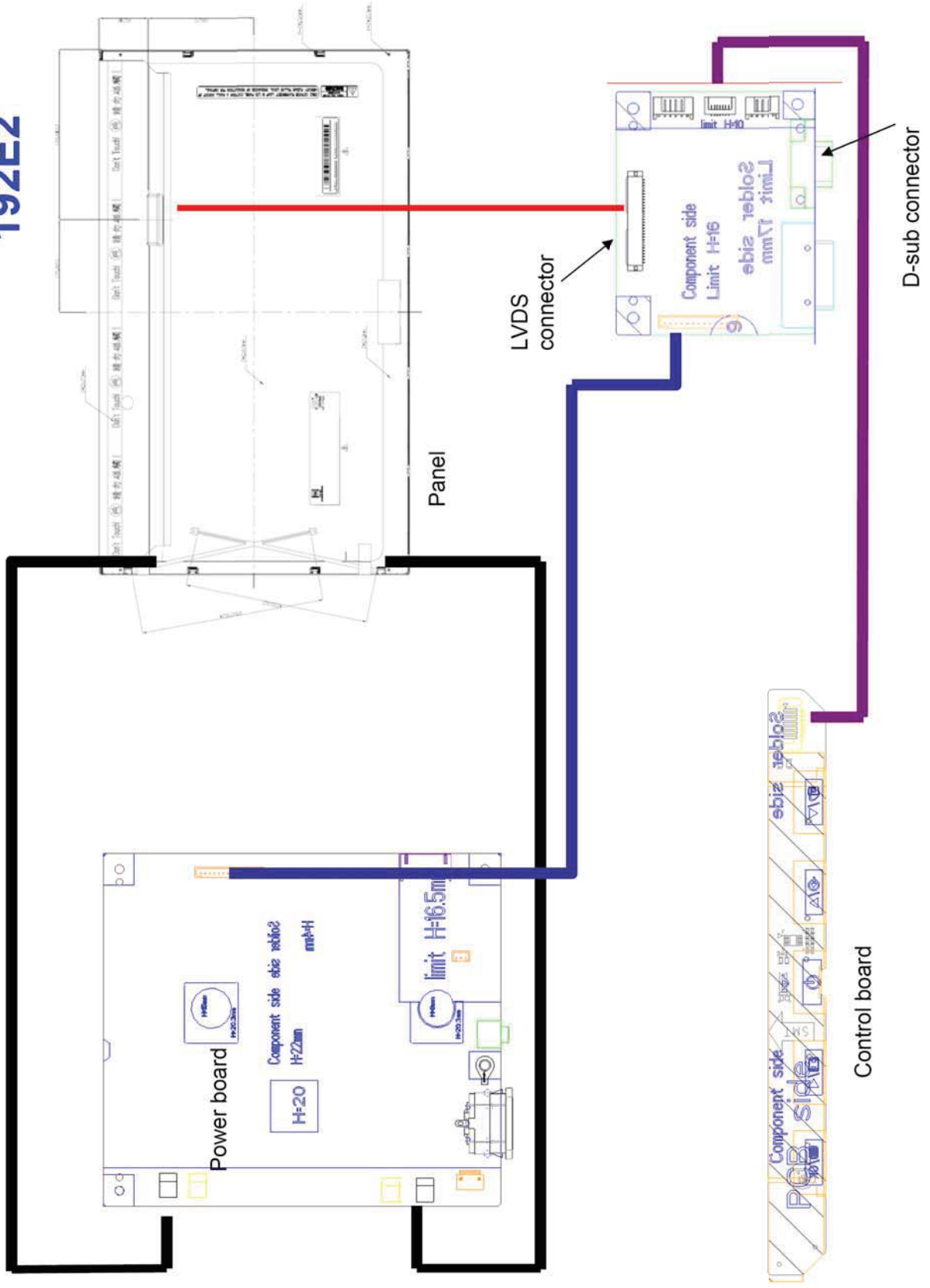

Block Diagram

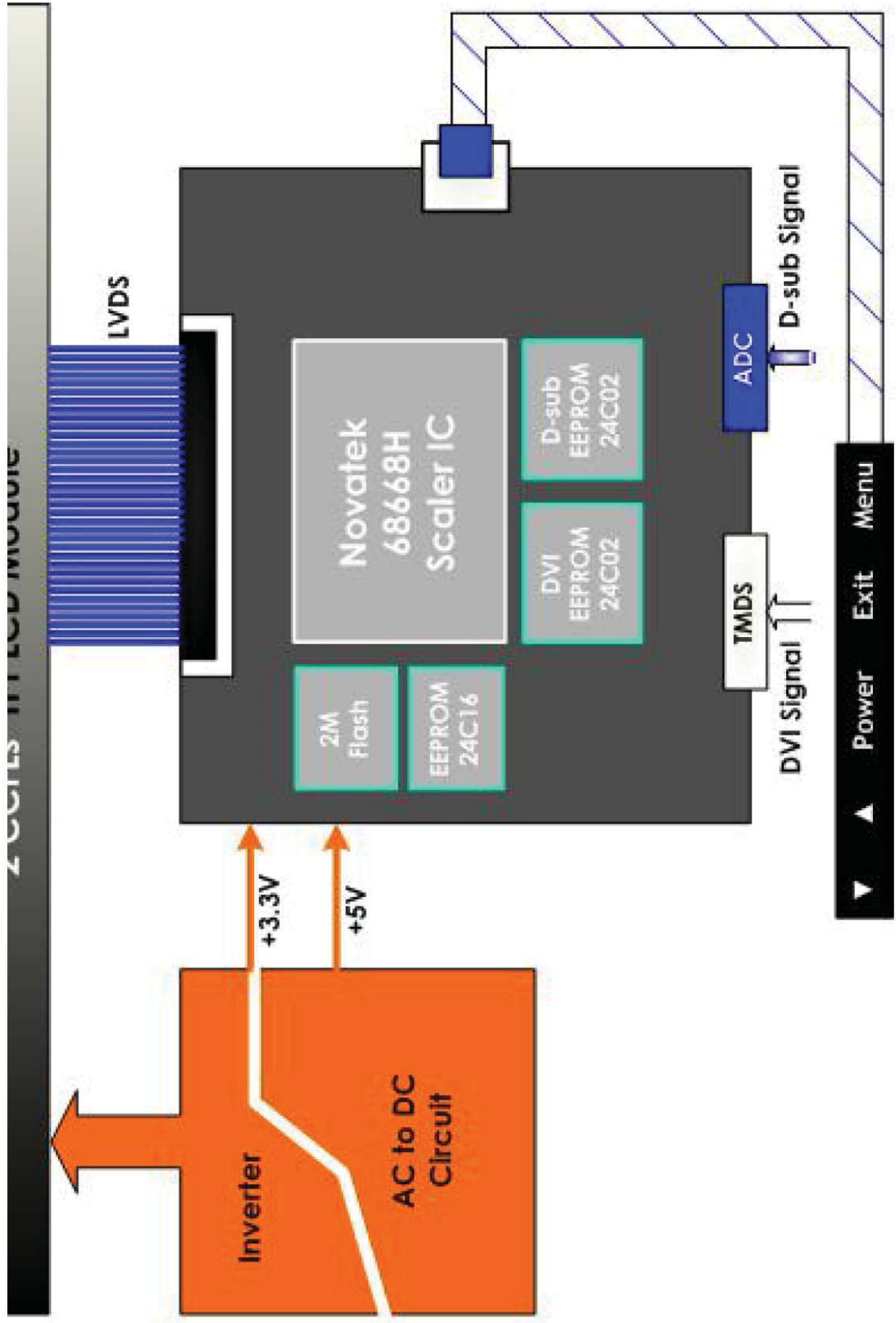

Scalar Diagram & C.B.A

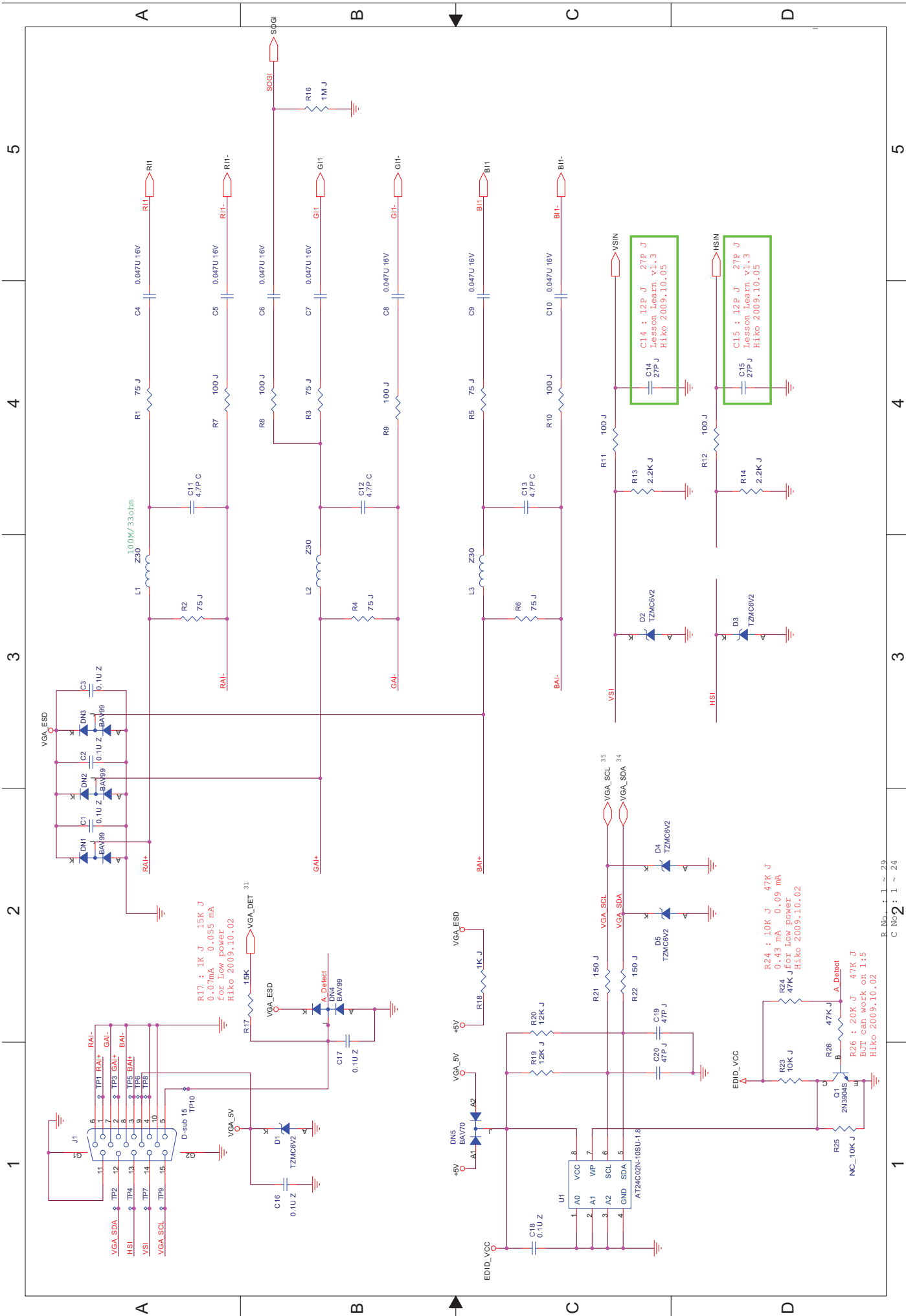

Scalar Diagram & C.B.A

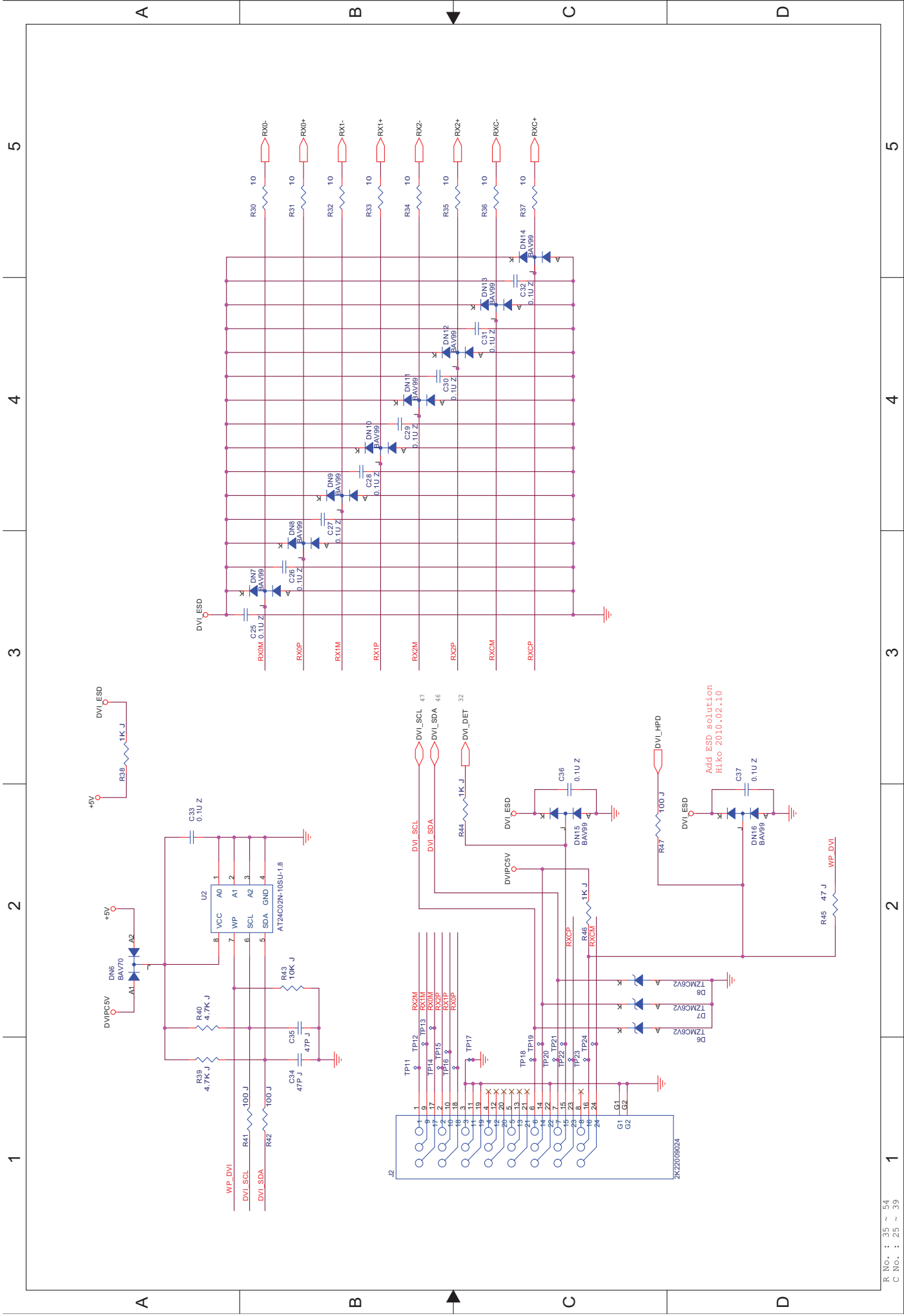

Scalar Diagram & C.B.A

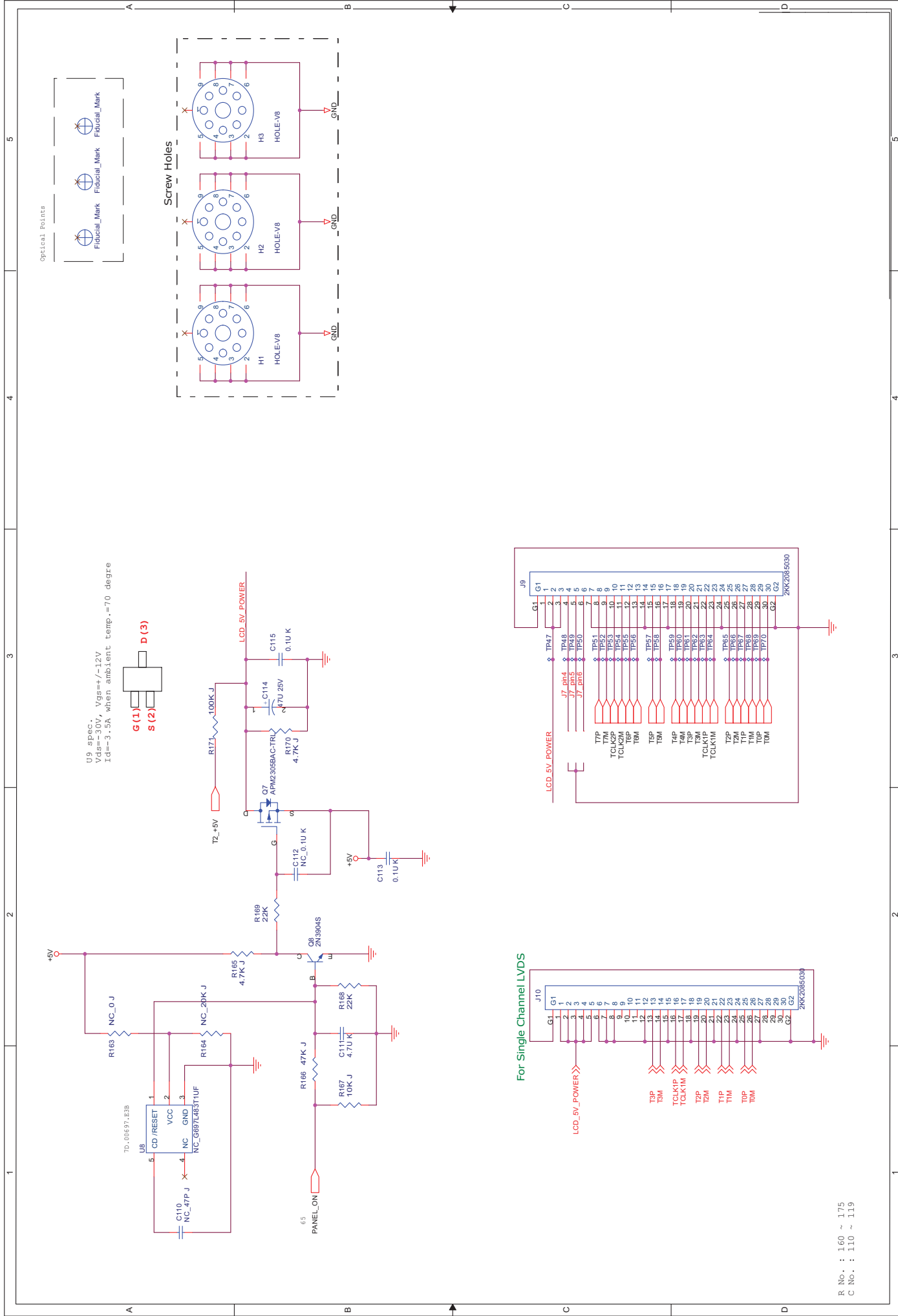

U9 spec.
 Vds=-30V, Vgs=-/-12V
 Id=-3.5A when ambient temp.=70 degree

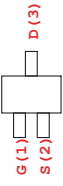

For Single Channel LVDS

Scalar Diagram & C.B.A

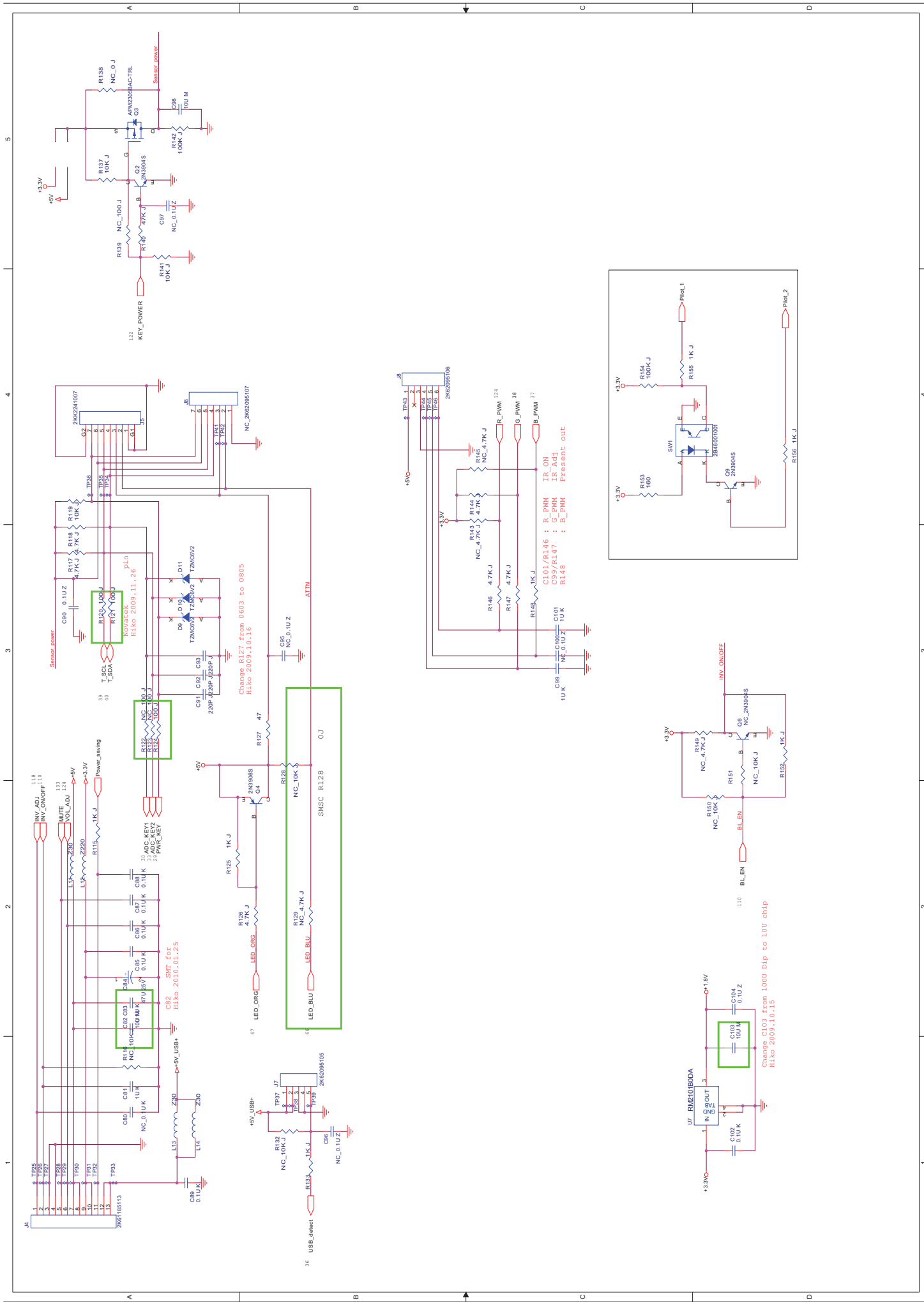

Scalar Diagram & C.B.A

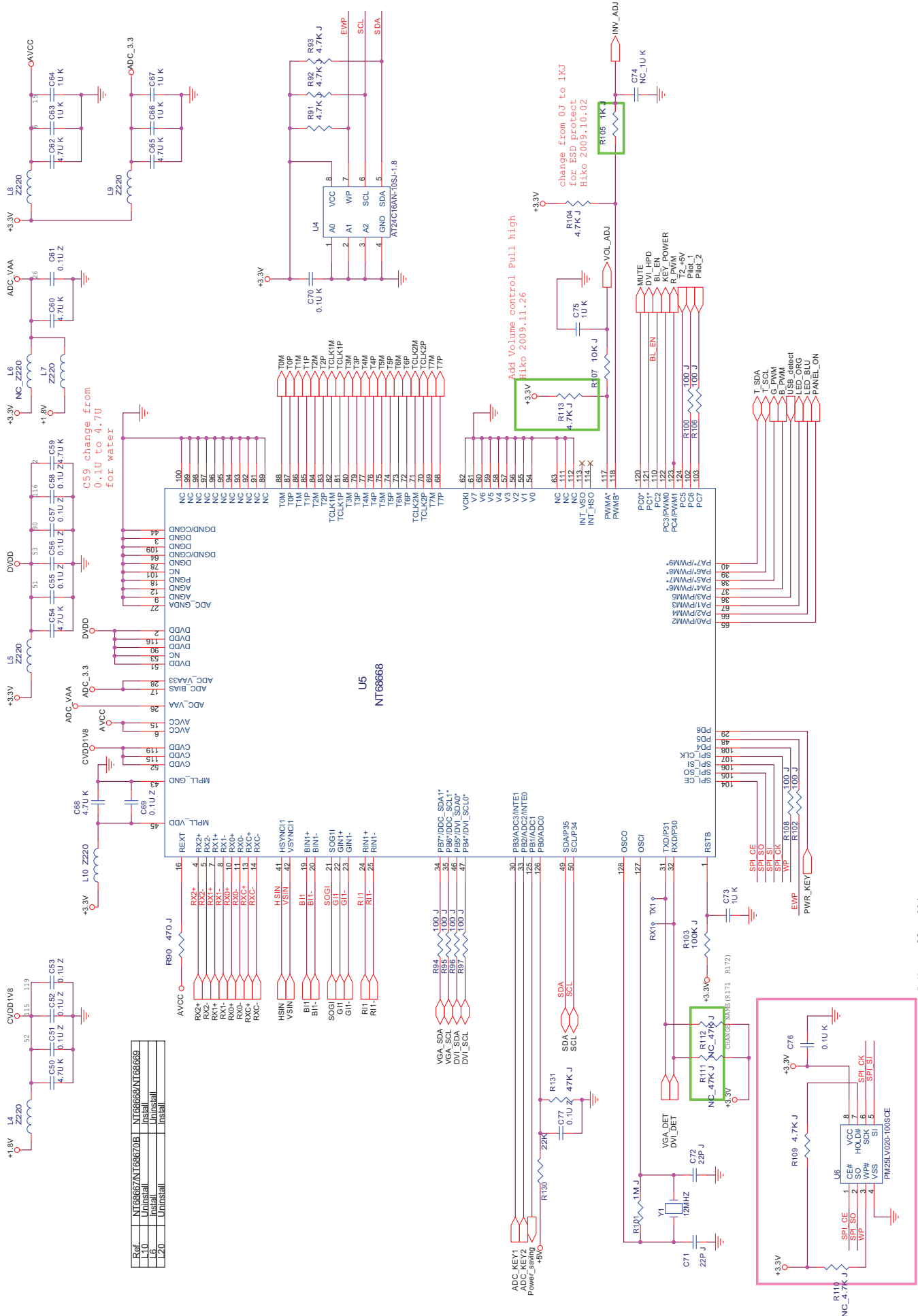

Ref	NT68667/NT68670B	NT68668/NT68669
10	Uninstall	Uninstall
16	Uninstall	Uninstall
20	Uninstall	Uninstall

Scalar Diagram & C.B.A

C 4 3 2 1

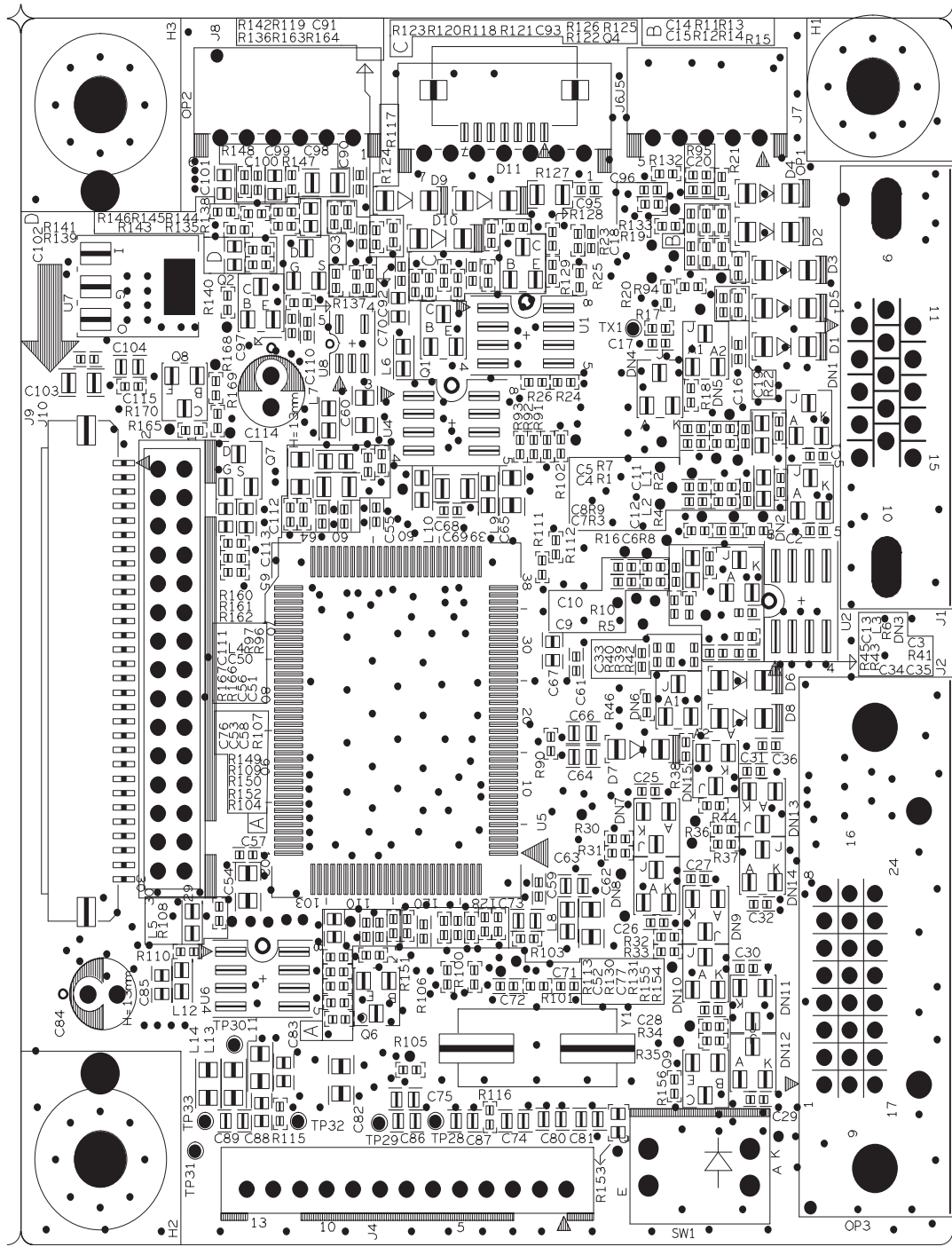

5 4 3 2 1

Information

Y1:	690
Y2:	380
Y3:	2100
Y4:	2025
Y5:	1350
Y6:	675
Y7:	337.5
Y8:	168.75
Y9:	84.375
Y10:	42.1875
Y11:	21.09375
Y12:	10.546875
Y13:	5.2734375
Y14:	2.63671875
Y15:	1.318359375
Y16:	0.6591796875
Y17:	0.32958984375
Y18:	0.164794921875
Y19:	0.0823974609375
Y20:	0.04119873046875
Y21:	0.020599365234375
Y22:	0.0102996826171875
Y23:	0.00514984130859375
Y24:	0.002574920654296875
Y25:	0.0012874603271484375
Y26:	0.00064373016357421875
Y27:	0.000321865081787109375
Y28:	0.0001609325408935546875
Y29:	8.046627044667722e-05
Y30:	4.023313522333861e-05
Y31:	2.0116567611669305e-05
Y32:	1.0058283805834652e-05
Y33:	5.029141902917326e-06
Y34:	2.514570951458663e-06
Y35:	1.2572854757293315e-06
Y36:	6.286427378646657e-07
Y37:	3.1432136893233285e-07
Y38:	1.5716068446616642e-07
Y39:	7.858034223308321e-08
Y40:	3.9290171116541605e-08
Y41:	1.9645085558270802e-08
Y42:	9.822542779135401e-09
Y43:	4.9112713895677005e-09
Y44:	2.4556356947838502e-09
Y45:	1.2278178473919251e-09
Y46:	6.1390892369596255e-10
Y47:	3.0695446184798127e-10
Y48:	1.5347723092399063e-10
Y49:	7.6738615461995315e-11
Y50:	3.8369307730997657e-11
Y51:	1.9184653865498828e-11
Y52:	9.592326932749414e-12
Y53:	4.796163466374707e-12
Y54:	2.3980817331873535e-12
Y55:	1.1990408665936767e-12
Y56:	5.9952043329683835e-13
Y57:	2.9976021664841917e-13
Y58:	1.4988010832420958e-13
Y59:	7.494005416210479e-14
Y60:	3.7470027081052395e-14
Y61:	1.8735013540526197e-14
Y62:	9.367506770263098e-15
Y63:	4.683753385131549e-15
Y64:	2.3418766925657745e-15
Y65:	1.1709383462828872e-15
Y66:	5.854691731414436e-16
Y67:	2.927345865707218e-16
Y68:	1.463672932853609e-16
Y69:	7.318364664268045e-17
Y70:	3.6591823321340225e-17
Y71:	1.8295911660670112e-17
Y72:	9.147955830335056e-18
Y73:	4.573977915167528e-18
Y74:	2.286988957583764e-18
Y75:	1.143494478791882e-18
Y76:	5.71747239395941e-19
Y77:	2.858736196979705e-19
Y78:	1.4293680984898525e-19
Y79:	7.1468404924492625e-20
Y80:	3.5734202462246312e-20
Y81:	1.7867101231123156e-20
Y82:	8.933550615561578e-21
Y83:	4.466775307780789e-21
Y84:	2.2333876538903945e-21
Y85:	1.1166938269451972e-21
Y86:	5.583469134725986e-22
Y87:	2.791734567362993e-22
Y88:	1.3958672836814965e-22
Y89:	6.9793364184074825e-23
Y90:	3.4896682092037412e-23
Y91:	1.7448341046018706e-23
Y92:	8.724170523009353e-24
Y93:	4.3620852615046765e-24
Y94:	2.1810426307523382e-24
Y95:	1.0905213153761691e-24
Y96:	5.4526065768808455e-25
Y97:	2.7263032884404227e-25
Y98:	1.3631516442202113e-25
Y99:	6.8157582211010565e-26
Y100:	3.4078791105505282e-26

FRONT

Power Diagram & C.B .A

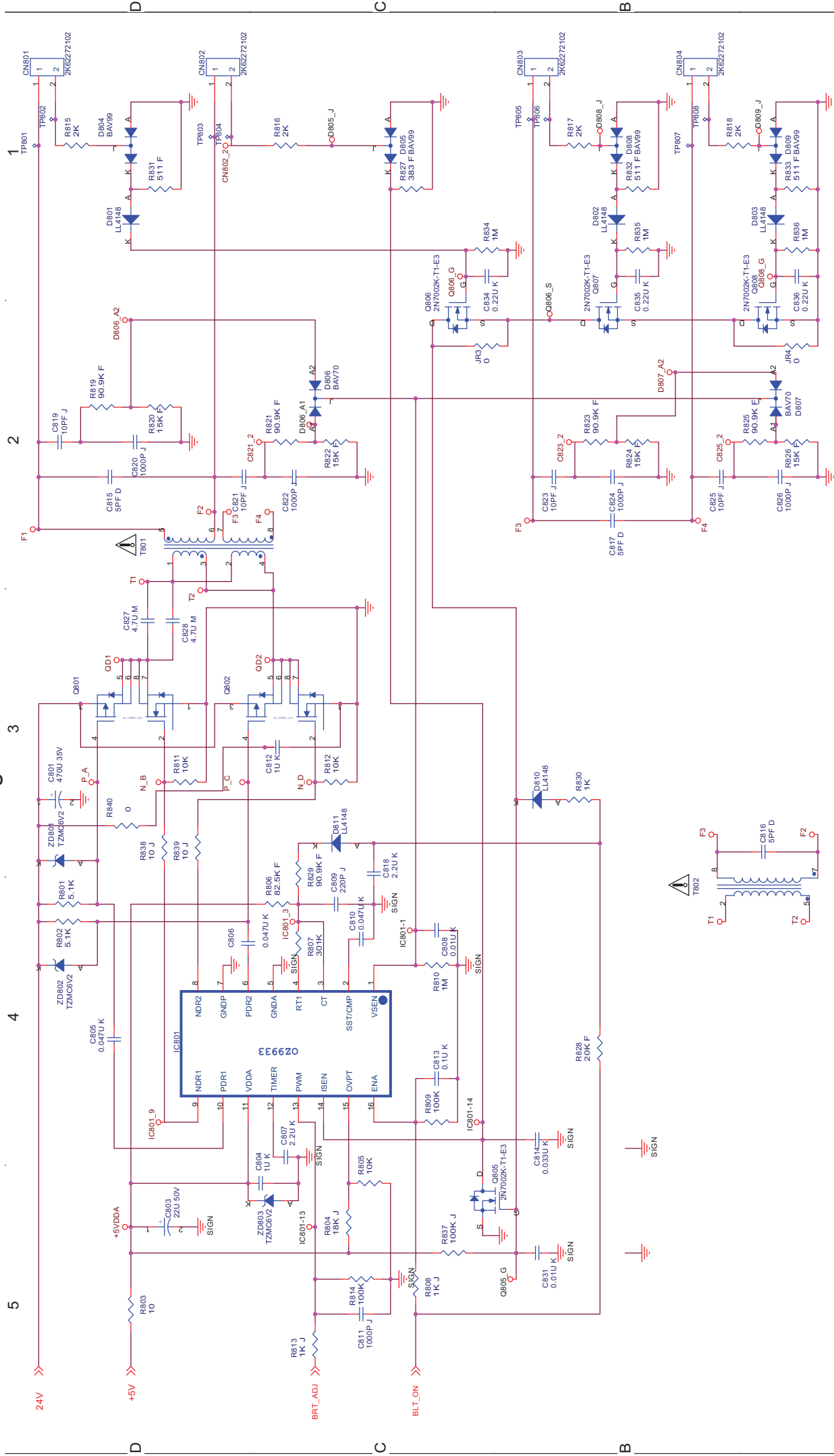

Power Diagram & C.B.A

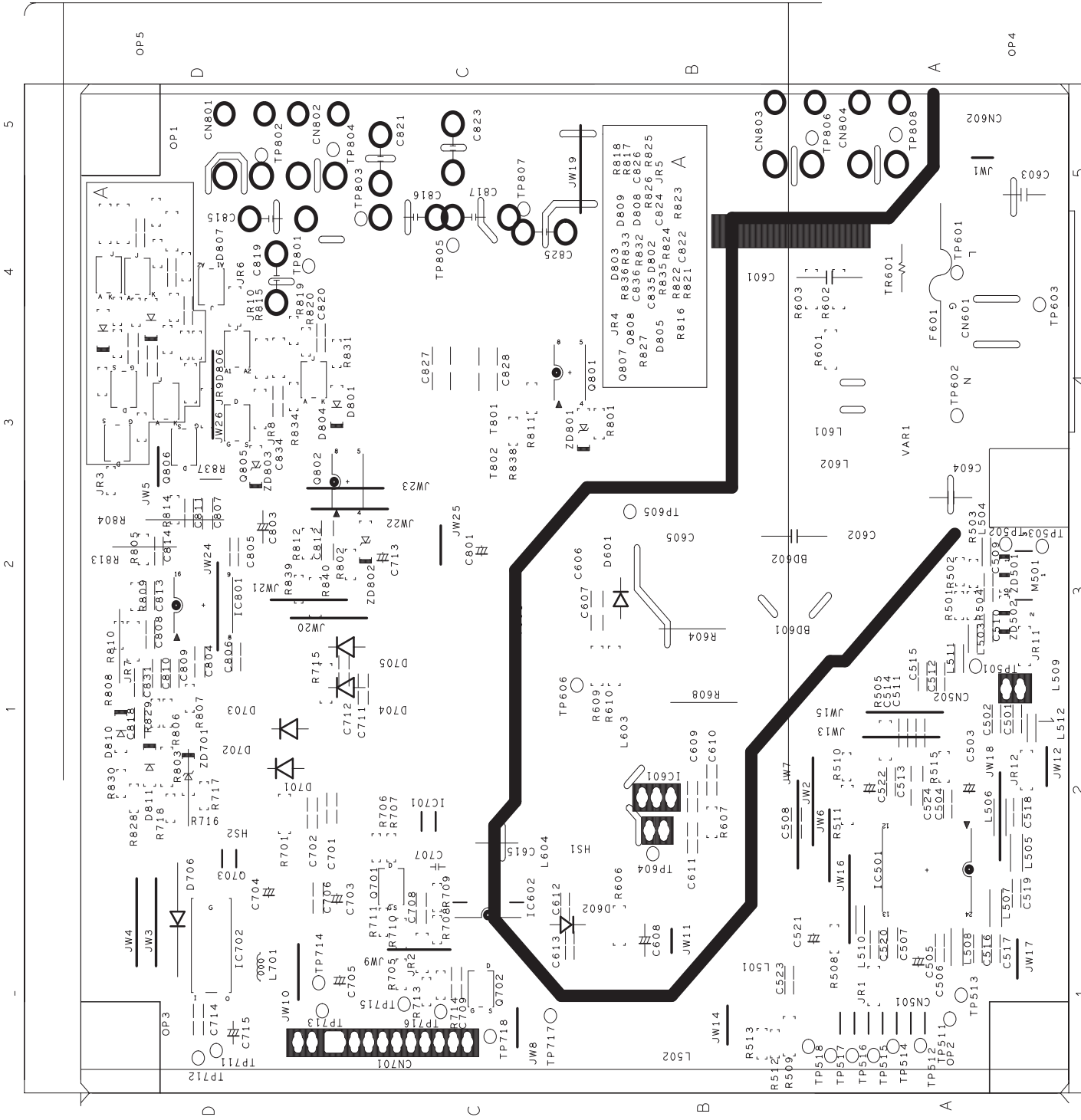

Position
 17200
 14200
 13000
 12000
 11000
 10000
 9000
 8000
 7000
 6000
 5000
 4000
 3000
 2000
 1000
 0
 Side

02
 01
 00
 99
 98
 97
 96
 95
 94
 93
 92
 91
 90
 89
 88
 87
 86
 85
 84
 83
 82
 81
 80
 79
 78
 77
 76
 75
 74
 73
 72
 71
 70
 69
 68
 67
 66
 65
 64
 63
 62
 61
 60
 59
 58
 57
 56
 55
 54
 53
 52
 51
 50
 49
 48
 47
 46
 45
 44
 43
 42
 41
 40
 39
 38
 37
 36
 35
 34
 33
 32
 31
 30
 29
 28
 27
 26
 25
 24
 23
 22
 21
 20
 19
 18
 17
 16
 15
 14
 13
 12
 11
 10
 09
 08
 07
 06
 05
 04
 03
 02
 01
 00

Control Diagram & C.B.A.

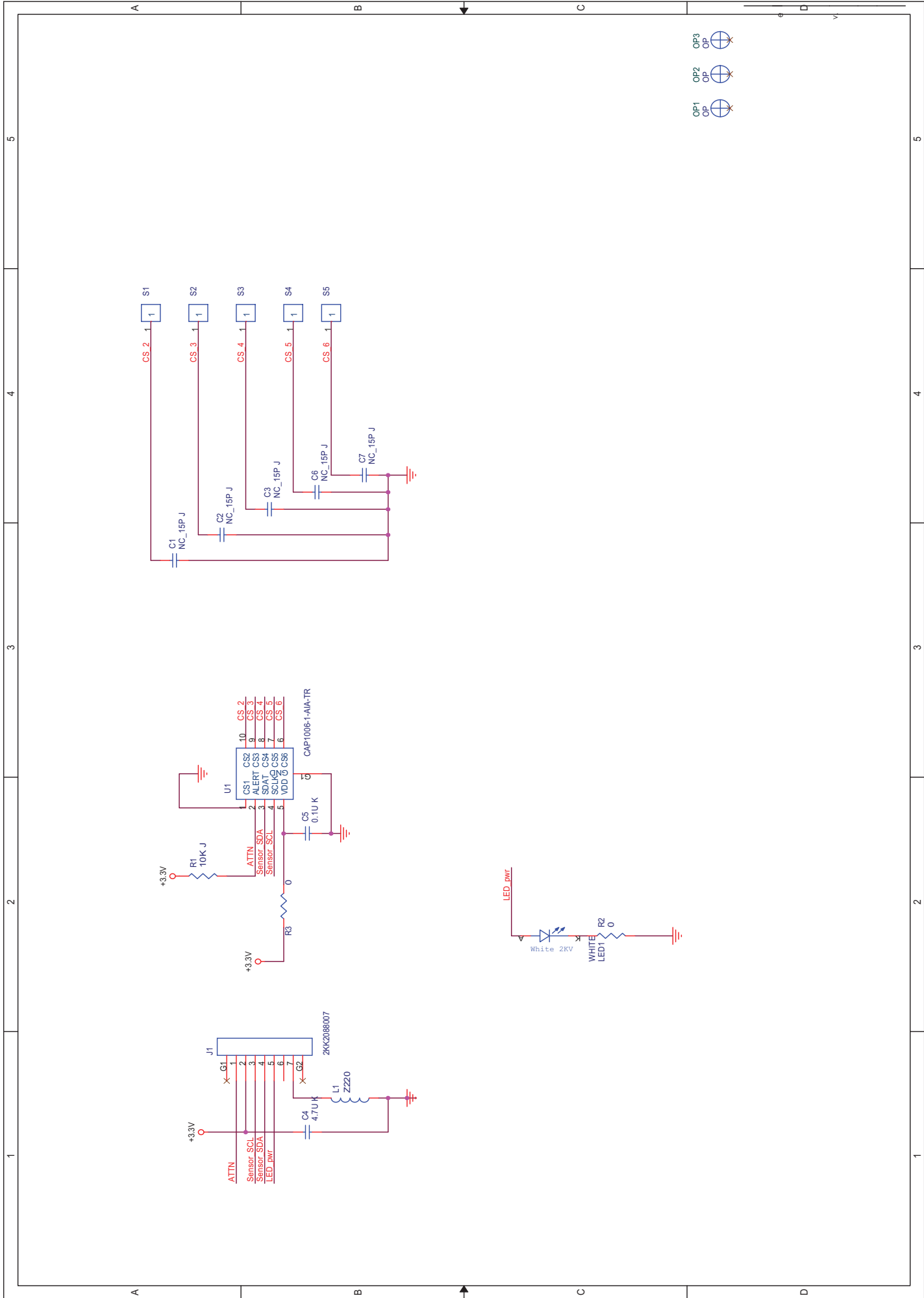

Control Diagram & C.B.A.

Information

Y1.: 256
 Y2.: 805
 X1.: 5229
 X2.: 4550
 X3.: 3900
 X4.: 3250
 X5.: 2600
 X6.: 1950
 X7.: 1300
 X8.: 650

Top Side
 A3.: L1
 A4.: S2
 A5.: C2
 A5.: C1
 A5.: C7
 A5.: C6
 A5.: C3
 A5.: S1
 A5.: S5
 A6.: S4
 A8.: S3
 B2.: J1
 B3.: C4
 B5.: C5
 B5.: R3
 B5.: U1
 B5.: R1
 B6.: R2
 B6.: LED1

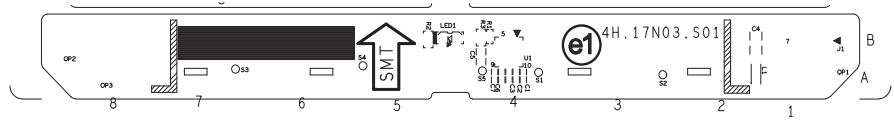

General Product Specification

**Meridian 2-192E2/192EL2
GENERAL PRODUCT
SPECIFICATION**

Issued by: Argent Chan/Paul Tsai

Revision History

Ver.	Date (yy.mm.dd)	Author	Brief Description

Blue: Changes than last version

Red: TBD

General Product Specification

ANALOG AND DIGITAL (optional) DUAL INPUT

- . AUTO PICTURE ADJUSTMENT
- . 43 PRESET MODES WHICH CAN BE RECOVERED TO PRESET MODES
- . USER FRIENDLY OSD DISPLAY FOR MODE IDENTIFICATION /ADJUSTMENT
- . MAX. RESOLUTION 1366 x 768 NON-INTERLACED AT 60 Hz
- . 18.5" COLOR TFT LCD FLAT PANEL
- . FULL RANGE POWER SUPPLY 90 – 264 VAC
- . CE ENVIRONMENTAL POLICY
- . ANTI-GLARE TO REDUCE LIGHT REFLECTION
- . POWER MANAGEMENT CAPABILITY
- . SOG SUPPORT
- . Windows Vista Premium Logo Certification
- . HDCP support
- . SMART CONTROL & SMART MANAGEMENT REQUIREMENT
- . SMARTContrast 2CCFL : 500,000:1 ; WLED : 20,000,000:1 (Typical)
- . SMART Image Lite
- . PrefectTune I (formerly FGA, FACTORY GAMMA Alignment)
- . PHILIPS LOGO displayed while power on
- . WEEE REQUIREMENT
- . RoHS REQUIREMENT
- . TCO 5.0 REQUIREMENT

General Product Specification

CONTENTS

- 1 FOREWORD6**
- 2 PRODUCT PROFILE6**
 - 2.1 EDID HEADER6
 - 2.2 PANEL SPEC6
 - 2.3 SCANNING FREQUENCIES10
 - 2.4 AMBIENT TEMPERATURE:10
- 3 ELECTRICAL CHARACTERISTICS10**
 - 3.1 INTERFACE SIGNALS11
 - 3.2 INTERFACE11
 - 3.3 TIMING REQUIREMENT13
 - 3.4 HORIZONTAL SCANNING14
 - 3.5 VERTICAL SCANNING14
 - 3.6 POWER INPUT CONNECTION15
 - 3.7 POWER MANAGEMENT15
 - 3.8 VGA DISPLAY IDENTIFICATION15
 - 3.9 DVI DISPLAY IDENTIFICATION15
 - 3.10 USB SUPPORT15
 - 3.11 DDC /CI SUPPORT AND SMART MANAGE/CONTROL15
 - 3.12 HOT-KEY DEFINITION15
 - 3.13 SMART CONTRAST (DYNAMIC CONTRAST RATIO)15
 - 3.14 SMART IMAGE16
 - 3.15 PERFECTTUNE19
- 4 VISUAL CHARACTERISTICS.....19**

General Product Specification

4.1	TEST CONDITIONS	19
4.2	BRIGHTNESS	19
4.3	IMAGE SIZE	19
4.4	BRIGHTNESS UNIFORMITY	20
4.5	CHECK CROSS TALK (S)	20
4.6	COLOR TEMPERATURE ADJUSTMENT	20
5	MECHANICAL CHARACTERISTICS	22
5.1	COSMETIC -	22
5.2	MECHANICAL DATA FILES -	22
5.3	LOCATION OF PHILIPS LOGO -	22
5.4	GAP BETWEEN PANEL AND FRONT BEZEL	22
5.5	LOCATION OF CONTROL ICONS -	22
5.6	COLOR FOR RESIN/PAINT -	22
5.7	FIRE ENCLOSURE REQUEST	22
5.8	RESINS	22
5.9	IF PAINT IS USED	22
5.10	PLASTIC MOLD TOOLING	22
5.11	PLASTICS FLAMMABILITY	23
5.12	TEXTURE/GLOSSING OF HOUSING	23
5.13	TILT AND SWIVEL BASE	23
5.14	KENSINGTON LOCK	23
5.15	LABEL	23
5.16	PRODUCT DIMENSION / WEIGHT (REFER TO PHILIPS APPROVED SHT 191/SHT560)	23
5.17	TRANSPORTATION	24
5.18	PALLET / CONTAINER LOADING (REFER TO PHILIPS APPROVED SHT 560)	25
6	ENVIRONMENTAL CHARACTERISTICS	25

General Product Specification

- 6.1 SUSCEPTIBILITY OF DISPLAY TO EXTERNAL ENVIRONMENT.....25
- 6.2 TRANSPORTATION TESTS26
- 6.3 DISPLAY DISTURBANCES FROM EXTERNAL ENVIRONMENT26
- 6.4 DISPLAY DISTURBANCES TO EXTERNAL ENVIRONMENT.....26
- 7 RELIABILITY26
 - 7.1 MEAN TIME BETWEEN FAILURES.....26
- 8 QUALITY ASSURANCE REQUIREMENTS.....26
 - 8.1 ACCEPTANCE TEST26
- 9 PHILIPS’ FLAT PANEL MONITORS PIXEL DEFECT POLICY27
- 10 REGULATORY COMPLIANCE30
 - 10.1 WORLDWIDE REGULATORY30
 - 10.2 EMC REQUIREMENTS.....30
 - 10.3 RoHS30
 - 10.4 WEEE30
 - 10.5 ONGOING REGULATORY30

General Product Specification

1 FOREWORD

This specification describes a 18.5" WXGA multi-scan color TFT LCD monitor with maximum resolution up to 1366 x 768 /60Hz non-interlaced. This model uses 250nits panel.

All optical characteristics are determined according to panel specification after warming up longer than 30 minutes.

2 PRODUCT PROFILE

2.1 EDID header

1	User visible strings on .inf file	Philips 192E (19inch WIDE LCD MONITOR 192E2) Philips 192EL (19inch WIDE LCD MONITOR 192EL2)
2	Manufacturer ID (EDID data)	PHL
3	Product ID, "xxxx" 4 codes	MSB(byte 12): C0 LSB (byte 11): 192E2:4D ; 192EL2:4E
4	maximum resolution	1366x768
5	Horizontal Frequency Range	30~83 KHz
6	Vertical Frequency Range	56~76Hz
7	Monitor Name (13 characters max.)	Philips 192E Philips 192EL

* Detail timing description in DVI EDID: Reduced blanking 1366 x768@60Hz

2.2 Panel spec

Suppliers to offer panel specifications.

Panel incoming specification: Follow Philips' specification.

192E2

SEC

Type NR. : SEC LTM185AT01
Resolution : 1366x768
Outline dimensions : 430.4(H) x 254.6(V) x 16.5(D) mm
Pixel Pitch (mm) : 0.300mm x 0.300mm
Color pixel arrangement : 1366 horizontal By 768 vertical Pixels. RGB stripe

arrangement

Display surface treatment : Hard coating (3H), Anti-glare treatment of the front polarizer
Color depth : 16.7 M colors 6-bit with H-FRC, 16.7M colors
Backlight : 2 CCFL
Active area (W x H) : Vertical 409.8mm x Horizontal 230.4mm
View angle (CR>10) : >=160 for H/V
Contrast ratio : 1000:1(Typ.)

General Product Specification

White luminance	: 250 nit(Typ.)
Color gamut	: >=72%
Gate IC	: LDI
Source IC	: N/A
Response time	: 5 ms
Vertical frequency range	: 47~75 Hz

CMO

Type NR.	: CMO M185B1-L02
Resolution	: 1366x768
Outline dimensions	: 430.4(H) x 254.6(V) x 16.25(D) mm
Pixel Pitch (mm)	: 0.300mm x 0.300mm
Color pixel arrangement	:1366 horizontal By 768 vertical Pixels. RGB stripe
Display surface treatment	: Hard coating (3H), Anti-glare treatment of the front polarizer
Color depth	: 16.7 M colors 6-bit with H-FRC, 16.7M colors
Backlight	: 2 CCFL
Active area (W x H)	: Vertical 409.8mm x Horizontal 230.4mm
View angle (CR>10)	: >=170/160 for H/V
Contrast ratio	: 1000:1(Typ.)
White luminance	: 250 nit(Typ.)
Color gamut	: >=72%
Gate IC	: HiMax/Novatek
Source IC	: HiMax
Response time	: 5 ms
Vertical frequency range	: 40~75 Hz

AUO

Type NR.	: AUO M185XW01 VB
Resolution	: 1366x768
Outline dimensions	: 430.4(H) x 254.6(V) x 11(D) mm
Pixel Pitch (mm)	: 0.300mm x 0.300mm
Color pixel arrangement	:1366 horizontal By 768 vertical Pixels. RGB stripe
Display surface treatment	: Hard coating (3H), Anti-glare treatment of the front polarizer
Color depth	: 16.7 M colors 6-bit with H-FRC, 16.7M colors
Backlight	: 2 CCFL
Active area (W x H)	: Vertical 409.8mm x Horizontal 230.4mm
View angle (CR>10)	: >=160 for H/V
Contrast ratio	: 1000:1(Typ.)
White luminance	: 250 nit(Typ.)
Color gamut	: >=72%
Gate IC	: LDI
Source IC	: N/A
Response time	: 5 ms
Vertical frequency range	: 47~75 Hz

General Product Specification

CPT

Type NR.	: CPT CLAA185WA03 V2
Resolution	: 1366x768
Outline dimensions	: 430.4(H) x 254.6(V) x 16.5(D) mm
Pixel Pitch (mm)	: 0.300mm x 0.300mm
Color pixel arrangement	:1366 horizontal By 768 vertical Pixels. RGB stripe
arrangement	
Display surface treatment	: Hard coating (3H), Anti-glare treatment of the front polarizer
Color depth	: 16.7 M colors 6-bit with H-FRC, 16.7M colors
Backlight	: 2 CCFL
Active area (W x H)	: Vertical 409.8mm x Horizontal 230.4mm
View angle (CR>10)	: >=160/160 for H/V
Contrast ratio	: 1000:1(Typ.)
White luminance	: 250 nit(Typ.)
Color gamut	: >=72%
Gate IC	: HiMax/Novatek
Source IC	: HiMax
Response time	: 5 ms
Vertical frequency range	: 40~75 Hz

192EL2**AUO**

Type NR.	: AUO M185WX01 V6
Resolution	: 1366x768
Outline dimensions	: 430.4(H) x 254.6(V) x 9.9(D) mm
Pixel Pitch (mm)	: 0.300mm x 0.300mm
Color pixel arrangement	:1366 horizontal By 768 vertical Pixels. RGB stripe
arrangement	
Display surface treatment	: Hard coating (3H), Anti-glare treatment of the front polarizer
Color depth	: 16.7 M colors 6-bit with H-FRC, 16.7M colors
Backlight	: WLED
Active area (W x H)	: Vertical 409.8mm x Horizontal 230.4mm
View angle (CR>10)	: >=170/160 for H/V
Contrast ratio	: 1000:1(Typ.)
White luminance	: 250 nit(Typ.)
Color gamut	: >=72%
Gate IC	: Raydium/Novatek
Source IC	: GOA
Response time	: 5 ms
Vertical frequency range	: 50~75 Hz

SEC

Type NR.	: SEC LTM185AT04
Resolution	: 1366x768
Outline dimensions	: 430.37(H) x 254.6(V) x 12.3(D) mm
Pixel Pitch (mm)	: 0.300mm x 0.300mm
Color pixel arrangement	:1366 horizontal By 768 vertical Pixels. RGB stripe
arrangement	

General Product Specification

Display surface treatment	: Hard coating (3H), Anti-glare treatment of the front polarizer
Color depth	: 16.7 M colors 6-bit with H-FRC, 16.7M colors
Backlight	: WLED
Active area (W x H)	: Vertical 409.8mm x Horizontal 230.4mm
View angle (CR>10)	: >=170/160 for H/V
Contrast ratio	: 1000:1(Typ.)
White luminance	: 250 nit(Typ.)
Color gamut	: >=72%
Gate IC	: Raydium/Novatek
Source IC	: GOA
Response time	: 5 ms
Vertical frequency range	: 50~75 Hz

AUO

Type NR.	: AUO M185WX01 VD
Resolution	: 1366x768
Outline dimensions	: 430.4(H) x 254.6(V) x 9.9(D) mm
Pixel Pitch (mm)	: 0.300mm x 0.300mm
Color pixel arrangement	:1366 horizontal By 768 vertical Pixels. RGB stripe

arrangement

Display surface treatment	: Hard coating (3H), Anti-glare treatment of the front polarizer
Color depth	: 16.7 M colors 6-bit with H-FRC, 16.7M colors
Backlight	: WLED
Active area (W x H)	: Vertical 409.8mm x Horizontal 230.4mm
View angle (CR>10)	: >=170/160 for H/V
Contrast ratio	: 1000:1(Typ.)
White luminance	: 250 nit(Typ.)
Color gamut	: >=72%
Gate IC	: Raydium/Novatek
Source IC	: GOA
Response time	: 5 ms
Vertical frequency range	: 50~75 Hz

CPT

Type NR.	: CPT CLAA185WA04 V2
Resolution	: 1366x768
Outline dimensions	: 430.4(H) x 254.6(V) x 11(D) mm
Pixel Pitch (mm)	: 0.300mm x 0.300mm
Color pixel arrangement	:1366 horizontal By 768 vertical Pixels. RGB stripe

arrangement

Display surface treatment	: Hard coating (3H), Anti-glare treatment of the front polarizer
Color depth	: 16.7 M colors 6-bit with H-FRC, 16.7M colors
Backlight	: WLED
Active area (W x H)	: Vertical 409.8mm x Horizontal 230.4mm
View angle (CR>10)	: >=160/160 for H/V
Contrast ratio	: 1000:1(Typ.)
White luminance	: 250 nit(Typ.)
Color gamut	: >=72%
Gate IC	: Raydium/Novatek
Source IC	: GOA

General Product Specification

Response time : 5 ms
Vertical frequency range : 50~75 Hz

CMI

Type NR. : CMI M185B3LA1
Resolution : 1366x768
Outline dimensions : 430.4(H) x 254.6(V) x 10.5(D) mm
Pixel Pitch (mm) : 0.300mm x 0.300mm
Color pixel arrangement : 1366 horizontal By 768 vertical Pixels. RGB stripe

arrangement

Display surface treatment : Hard coating (3H), Anti-glare treatment of the front polarizer
Color depth : 16.7 M colors 6-bit with H-FRC, 16.7M colors
Backlight : WLED
Active area (W x H) : Vertical 409.8mm x Horizontal 230.4mm
View angle (CR>10) : >=160/160 for H/V
Contrast ratio : 1000:1(Typ.)
White luminance : 250 nit(Typ.)
Color gamut : >=72%
Gate IC : Raydium/Novatek
Source IC : GOA
Response time : 5 ms
Vertical frequency range : 50~75 Hz

2.3 Scanning frequencies

Hor. : 30 - 83 K Hz
Ver. : 56 - 76 Hz

Video dot rate: < 140 MHz for VGA and < 140 MHz for DVI, warning message must be displayed while over 165 MHz (supplier to provide accurate scalar bandwidth number)

Power input: 90-264 V AC, 50/60 ± 2 Hz

Power consumption:

On mode: < 30W (max.), 24W (typ.)

EPA 5.0 spec. < 16.5 watt

EPA 5.0 measure data < 16.5 watt

Functions:

- (1) D-SUB analog R/G/B separate inputs, H/V sync separated, Composite (H+V) TTL level, SOG sync
- (2) DVI digital Panel Link TMDS inputs, HDCP supported.

2.4 Ambient temperature:

0 °C - 40 °C

3 Electrical characteristics

Scaler should be capable of below items.

- 1) Scaler must support color engine for Image enhancement feature (SmartImage)
- 2) Scaler must have enough memory to support PerfecTune feature and Philips OSD

General Product Specification

3) Scaler must support smart contrast

2CCFL model 500,000:1 . WLED model : 20,000,000:1

3.1 Interface signals

1). D-Sub Analog

Input signal : Video, Hsync., Vsync
 Video : 0.7 Vp-p, input impedance, 75 ohm @DC
 Sync. : Separate sync TTL level, input impedance 2.2k ohm terminate
 Hsync Positive/Negative
 Vsync Positive/Negative

Composite sync TTL level, input impedance 2.2k ohm terminate (Positive/Negative)
 Sync on green video 0.3 Vp-p Negative (Video 0.7 Vp-p Positive)

2). DVI-D Digital

Input signal: Single TMDS link (Three channels: RX0-/+ , RX1-/+ , RX2-/+)

3). USB HUB

N/A

4). Audio

N/A

3.2 Interface

3.2.1 D-Sub Cable

Length : 1.8 M +/- 50 mm
 Fix with monitor when packing, with transplant pin protective cover.

Connector type : D-Sub male with DDC2B pin assignments.
 Blue connector thumb-operated jack screws

General Product Specification

PIN No.	SIGNAL
1	Red
2	Green/ SOG
3	Blue
4	Sense (GND)
5	Cable Detect (GND)
6	Red GND
7	Green GND
8	Blue GND
9	DDC +3.3V or +5V
10	Logic GND
11	Sense (GND)
12	Bi-directional data
13	H/H+V sync
14	V-sync
15	Data clock

3.2.2 DVI Cable

The input signals are applied to the display through DVI-D cable.

Length : 1.8 M +/- 50 mm

Connector type : DVI-D male with DDC-2B pin assignments

White connector thumb-operated jackscrews. With transplant pin protective cover.

Pin No.	Description
1	T.M.D.S. data2-
2	T.M.D.S. data2+
3	T.M.D.S. data2 shield
4	No Connect
5	No Connect
6	DDC clock
7	DDC data
8	No Connect
9	T.M.D.S. data1-
10	T.M.D.S. data1+
11	T.M.D.S. data1 shield
12	No Connect
13	No Connect
14	+5V Power
15	Ground (for +5V)
16	Hot plug detect
17	T.M.D.S. data0-
18	T.M.D.S. data0+
19	T.M.D.S. data0 shield
20	No Connect
21	No Connect
22	T.M.D.S clock shield
23	T.M.D.S. clock+
24	T.M.D.S. clock-

General Product Specification

3.3 Timing requirement

Factory Preset mode definition:

1. Perfect FOS while presenting those timings.
2. Will specify those timing in User's Manual

Preset mode definition:

1. Need to support those timings.
2. Perfect FOS after auto adjustment.

User mode

1. Can save those timing that not in Preset mode and can be showed (not over scaler or Panel spec.)
2. It needs to reserve the 10 timings space in memory size.

3.3.1 Mode storing capacity

Preset modes : 43



192E(L)2 Timing
Table.xls

Video timing mode (internal firmware support) ,

60Hz: 480p/720p/1080i/1080p





50Hz: 576p/720p/1080i/1080p

For these video timings , can only approve shown on screen, but not make sure has right picture quality.

General Product Specification

3.3.3 Software control functions via OSD / control adjustable functions:

Please refer to following M1 OSD definitions, if any deviation, then refer to PVT Exit sample.

ITEM			
1	OSD DEFINITIONS	 Hudson 8 OSD Definition - v14.doc	Reset - No: Exit Yes: Auto adjustment for displaying timing mode and recall factory preset
2	OSD LANGUAGES	  H8 OSD translation - H9 new item 20070425 - Final.xls translation _ 2008041	8 LANGUAGES
3	OSD TREE	 M2 OSD Button definition _ 20100125	
4	POWER ON LOGO	 19W_1366x768_new .bmp	Power On Logo: Power On → Show up Philips logo 3 seconds → Change to input signal. This picture is reference only. The official drawing will send out by PM.
5	Audio Selection	Stand-alone - On: Isolate video and audio control input Stand-alone - Off: Integrate video and audio control input Mute - On: Turn off audio Mute - Off: Turn on audio	

3.4 Horizontal scanning

Sync polarity : Positive or Negative
Scanning frequency : 30 - 83 K Hz

3.5 Vertical scanning

Sync polarity : Positive or Negative
Scanning frequency : 56 - 76 Hz

General Product Specification

3.6 Power input connection

Power cord length : 1.5 M
 Power cord type : 3 leads power cord with protective earth plug.

3.7 Power management

The monitor must comply with the Microsoft On Now specification, and meet EPA requirements.

Mode	HSYNC	VSYNC	Video	Pwr-cons.	Indication	Rec. time
Power-On	On	On	Active	<24W (typ.) < 30W(max.) EPA5.0<16.5W	White LED	--
Standby	Off	Off	Blanked	< 0.5W	Blinking white LED Period 1sec on 3sec off	< 3 s
DC Power Off			N/A	< 0.5W	LED Off	

3.8 VGA Display identification

In accordance with VESA Display Channel Standard Ver.1.0 and DDC 2B capability

3.9 DVI Display identification

In accordance with DVI requirement (DDWG digital Visual Interface revision 1.0) use DDC-2B, DDC/CI, and EDID V1.3

3.10 USB support

Connect the upstream port of the monitor to host PC's USB port via USB cable. Then attach external device to the downstream port of the monitor. Check if the device can work properly.

3.11 DDC /CI Support and Smart Manage/Control

In accordance with VESA DDC/CI and MCCS ver.2.0, the monitor should be workable with , Philips SmartManage, SmartControl V6.1, and Protrait Display Tune at least.

3.12 Hot-key definition



D:\ENG\monitor
 projects\spec\H8\hot k

3.13 Smart contrast

Smart Contrast is a kind of dynamic backlight control.

This function changes the panel backlight dynamically according to the frame brightness histogram. 2CCFL model 500,000:1 . WLED model : 20,000,000:1

General Product Specification

3.14 Smart image

3.14.1 Smart Image OSD outlook

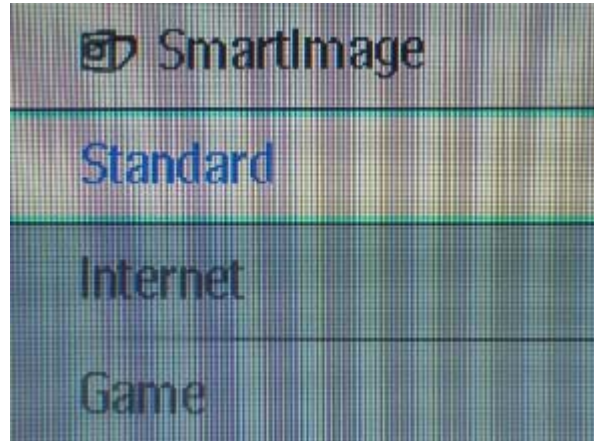

3.14.1.1 Position

The position of the button is at the bottom center of the screen.

3.14.1.2 Smart Image Logo & Banner

As design to keep the LightFrame logo at header but change the name to “SmartImage” with bitmap format.

3.14.1.3 Icon of each profile

Each profile will use text instead of icon & text before.

3.14.1.4 User Operation Procedure

- A. 3 different modes are switched to next in the sequence from 1 to 3 then back to 1 while pressing this button: 1) Standard 2) Internet 3)Game. The default setting is ‘Standard’.
- B. The FOS optimization will be changed in real time by which profile to be scrolled, users don’t need to confirm to enable.
- C. The SmartImage Lite OSD will remain on screen for 5 seconds after user last action. Or user can also press [MENU] to close the Smart Image OSD immediately.
- D. Except using [MENU] button to scroll down profile. If Smart Image OSD already launched onscreen. User is allowed to use up/down key to choose profile and press [MENU] to confirm selection and close the Smart Image OSD.

General Product Specification

- E. If the model has multiple inputs including VGA , DVI each input has their own set of profiles. When user switch input, the profile to be applied will also change.
- F. Each input can memorize their individual “SmartImage Lite” profile status.
For example, SmartImage is on with “Game” profile at VGA input, when switch to DVI input, the Smart Image will revert to previous profile of DVI.
In the input switching process the “SmartImage” OSD will also show up to present which profile is selected if “Smart Image” is enabled at that input.
The Smart Image status will also be stored after the monitor is resumed from AC on/off or power switch on/off.

3.14.1.5 Linkage between Smart Image OSD and main OSD

- A. Settings within main OSD have linkage with Smart Image OSD.
- i. Brightness
 - ii. Contrast
 - iii. Color Temperature
- B. Because each preset profiles will define default setting of these 3 parameters. Users can understand what is the value of that in preset profile by open the main OSD.
- C. When any SmartImage Lite profile had been enabled. The parameters in main OSD are still available for user to adjust. But these adjustments are temporary only. If users switch to another profile and then go back. The setting in main OSD will show preset values of that SmartImage profile enabled.

3.14.1.6 Profile Definitions (system integrators to input at design stages)

A. Standard

- i. Purpose: Default out of box settings, No optimization by SmartImage.
- ii. Design:
 1. This will follow user OSD setting. If any change by user, it will be saved. When switch back from other SmartImage profiles, it will go back to last saved setting.
 2. Default out of box settings.
 3. Same as OFF mode settings in SmartImage.

General Product Specification

B. Internet

- i. Purpose: Design for Internet application, especially web browsing.
The screen is mixed by text & picture. Desktop publish could use this profile also.
- ii. Enhancement Point:
 1. The enhancement will be mostly based on the "Image viewing" settings that are also under definition, made milder by the higher probability of strong compression typical of the Internet photos and clips.
 2. Color temperature should be 6500° K.
 3. Brightness level should be around 90%
 4. SmartResponse set to "Low".
 5. Smart Contrast set to "Off".

C. Game

- i. Purpose: Design for PC game software and game boxes, e.g. PS3 and Xbox. The screen is dominated by artificial animation with rich color.
- ii. Enhancement Point:
 1. Dynamic contrast enhancement by histogram analysis should be implemented.
 2. Sharpness enhanced 90%.
 3. Color enhancement set as the same with Video.
 4. Color temperature set to panel native(original color temp).
 5. Brightness level sets to maximum
 6. SmartResponse set to "High".
 7. Gamma Table turn off to achieve fastest response time.
 8. SmartContrast set to "On".

3.14.1.7 Demo mode

- A. Purpose: Built-in demo mode for sales in-store demo.
- B. Design:
 - i. Dynamically split screen to 2 vertical frames with one vertical white line. The line width is 2 pixels. The left frame will be enhanced by SmartImage Lite and right frame remains original performance.

General Product Specification

- ii. There is OSD showing “SmartImage Lite & SmartResponse Demonstration” in left frame and “Original Image” in right frame.
 - iii. The OSD word color is white with transparent background.
 - iv. The demo profile will be “Video Playback” profile with “High” ODC setting.
 - v. The current SmartContrast value also be shown on the bottom of the screen.
- C. Hot keys to trigger:
- Press [Smart Image] 3 seconds or more to trigger the demo mode.
 - When demo mode is On, press 3 seconds or more to turn off the demo mode.
 - When the demo mode is enabled, the blue LED will flash until demo mode disabled.

3.15 PerfectTune

- A. PerfectTune must be done after warming 30 minutes at least.
- B. PerfectTune must be performed after Auto Color.
- C. PerfectTune must be conducted through DVI or scaler embedded patterns.
- D. Delta E < 2.5

4 Visual characteristics

4.1 Test conditions

Unless otherwise specified, this specification is defined under the following conditions.

- (1) Input signal : As defined in 3.3, 1366 x 768 non-interlaced mode (1366 x 768@06Hz), signal sources must have 75 ohm output impedance.
- (2) Luminance setting : controls to be set to 250 nits with full screen 100 % duty cycle white signal
- (3) Warm up: more than 30 minutes after power on with signal supplied.
- (4) Ambient light: 400 -- 600 lux.
- (5) Ambient temperature: 20 ± 5 °C

4.2 Brightness

Follow Panel specification.

4.3 Image size

Actual display size 337.920 mm x 270.336 mm

General Product Specification

4.4 Brightness uniformity

Set contrast at 100% and turn the brightness to get average above 300 nits at centre of the screen.

Apply the Fig 1, it should comply with the following formula:

$$\frac{(B_{\max} - B_{\min})}{B_{\max}} \times 100\% > 75\%$$

Where B_{\max} = Maximum brightness
 B_{\min} = Minimum brightness

4.5 Check Cross talk (S)

Apply Pattern 2. Set contrast and brightness at 100 %.
 Measure YA. Then output Pattern 3 and measure YB.
 the cross talk value :

$$\frac{ABS (YA - YB)}{YA} \times 100\% < 1.5 \%$$

4.6 Color temperature adjustment

There are three factory preset white color 9300K, 6500K, sRGB.

Apply full white pattern, with brightness in 100 % position and the contrast control at 50 % position.

The 1931 CIE Chromaticity (color triangle) diagram (x ,y) coordinate for the screen center should be:

Product specification

CIE coordinates	(x,y)	
9300K	x = 0.283 ± 0.02 y = 0.297 ± 0.02	PerfecTune I
6500K/sRGB	x = 0.313 ± 0.02 y = 0.329 ± 0.02	PerfecTune I

General Product Specification

Production alignment spec

CIE coordinates	(x,y)	
9300K	x = 0.283 ± 0.006 y = 0.297 ± 0.006	PerfectTune I
6500K/sRGB	x = 0.313 ± 0.006 y = 0.329 ± 0.006	PerfectTune I

Quality Inspection specification

CIE coordinates	(x,y)	
9300K	x = 0.283 ± 0.015 y = 0.297 ± 0.015	
6500K/sRGB	x = 0.313 ± 0.015 y = 0.329 ± 0.015	

General Product Specification

5 Mechanical characteristics

5.1 Cosmetic -

Philips ID

5.2 Mechanical data files -

ProE files required

5.3 Location of Philips logo -

Per Philips make-up sheet

5.4 Gap between panel and front bezel

< 1.0mm (Typ.)

5.5 Location of Control icons -

Per Philips Graphic sheet

5.6 Color for resin/paint -

Per Philips make-up sheet

5.7 Fire enclosure request

Shielding Cover should fulfill international standard

5.8 Resins

- RoHS required
- WEEE required.
- Resin type/selection refer to Project Book Section 7.2 Plastic material.

5.9 If paint is used

- RoHS required
- WEEE require
- If new painting type need to implement, refer to UN-D 1235.

5.10 Plastic mold tooling

- Tooling to be designed to minimize cosmetic defects induced by molding process (sink, blush, weld lines, gate marks, ejector marks, etc.). Refer to "TYV61-90007".

General Product Specification

- Painting to cover up cosmetic defects due to molding is strongly discouraged.
- China RoHS mark requested.

5.11 Plastics flammability

- All Plastics to be Flame Retardant UL 94-HB or Better.
- Base / Pedestal to be Flame Retardant UL 94-HB.
- All major plastic parts (bezel, back cover) need to be molded from same resin.
- Plastic resin type selection should be referred to “plastic-Philips Pool monitor”.

5.12 Texture/Glossing of housing

- The texture area and texture no should follow Philips make-up sheet.
- The exterior surfaces shall have a uniform texture.
- Philips must approve the mold texturing.
- Detail document for texture refer to “UN-D249”, “UN-D 600”.
- ≤ 20 gloss units

5.13 Tilt and swivel base

- Tilt angle : $-5^\circ +2/- 0^\circ$ (forward)
 $+20^\circ + 0/- 3^\circ$ (backward)
- Swivel angle : nil
- High Adjustment : nil
- Portrait Display : nil

5.14 Kensington Lock

- Must meet Kensington_slot.spec “TYE-M0004”.
- MMD request metal plate in Kensington hole.

5.15 Label

- Regulatory label / Carton label should follow Philips requirement.
- China RoHS label
- Detail document refer to Philips Engineering Reference Book.

5.16 Product dimension / Weight (Refer to Philips approved SHT 191/SHT560)

- Unit dimension : 457.44mm(W) * 363.27mm(H) * 180.02mm(D)
- Packed unit dimension: WW–503mm(W) * 416mm(H) * 141mm(D)

General Product Specification

China—510mm(W) * 418mm(H) * 160mm(D)

- Net weight : 3.9 Kg
- Gross weight : 5.0 Kg(WW) ; 5.1 Kg(China)

5.17 Transportation

Transportation standards refer to UAN-D1534/00/01/02.

5.17.1 Transportation packages

- Net weight Packaging and wrapping shall be sufficient to protect the product against damage or loss during shipment from the supplier to the destination specified in the purchase order. All packaging materials are subject to test and evaluation per UAN-D1534/00/01/02.
- The cushion material shall be constructed using EPS material.
- The doggy hole is requested.

5.17.2 Transportation Test

Overall tests refer to UAN-D1534/00/01/02.

Vibration, drop test should be performed at ambient temperature (20°C to 23°C) and relative humidity (40% to 65%).

A. Transportation test specification for all regions

- Package test
 1. Random Vibration test
 2. Drop test
 3. Cold Drop test (for design reference)
- Un-package test
 4. Half sine shock test (non operation)
 5. B. Transportation test specification for China/India
 6. Package test
 7. Random Vibration test
 8. Drop test
 9. Cold Drop test (for design reference)
 10. Un-package test
 11. Sine vibration (operating)

General Product Specification

12. Half sine shock test (non operation)

5.18 Pallet / Container loading (Refer to Philips approved SHT 560)

Transportation standards refer to TYE-M0002 ,UAN-D1534 and UAW-0309.

- Air shipment - A: W1138*L1016 ; B: W1138*L513 (WW)
B: W1130*L1030 ; B: W1130*L520 (China)
- Sea container 20'(pallet/slip sheet) - 10/2
- Sea container 40'(pallet/slip sheet) - 22/2
- Sea container 40' High Cube (pallet/slip sheet) - 22/2
- Land 45' Truck and Trailer (800X1200mm pallet) - NA
- Land 45' Truck and Trailer (1000X1200mm pallet) for UK - 26
- Truck shipment-

Transportation request for all regions except China/India

- A. Air shipment
- B. 20'/40'/40'HQ Container loading for WW - 848/1808/1984 (Pallet)
848/1808/2160 (Slipsheet)

Transportation request for China and India

- A. Container loading for China and India - 742/1582/1670 (Pallet)
742/1582/1890 (Slipsheet)
- B. Truck loading

Transportation request for EU

- A. Land 45' Truck and Trailer (800X1200mm pallet)
- B. Land 45' Truck and Trailer (1000X1200mm pallet) for UK - 2080

6 Environmental characteristics

The following sections define the interference and susceptibility condition limits that might occur between external environment and the display device.

6.1 Susceptibility of display to external environment

Operating

- Temperature : 0 to 40 degree C

General Product Specification

- Humidity : 80% max
- Altitude : 0-3658m
- Air pressure : 600-1100 mBAR

Storage

- Temperature : -20 to 60 degree C
- Humidity : 95% max
- Altitude : 0-12192m
- Air pressure : 300-1100 mBAR

Note: recommend at 5 to 35°C, Humidity less than 60 %

6.2 Transportation tests

Refer to 5.15.2

6.3 Display disturbances from external environment

According to IEC 801-2 for ESD disturbances

6.4 Display disturbances to external environment

7 Reliability

7.1 Mean Time between Failures

System MTBF (Including the LCD panel and CCFL) : 30,000 hrs

8 Quality assurance requirements

8.1 Acceptance test

According to MIL-STD-1916D Control III level

AQL: NA

(Please also refer to annual quality agreement)

Customer acceptance criteria: UAW0377/00

General Product Specification

9 Philips' Flat Panel Monitors Pixel Defect Policy

Philips' Flat Panel Monitors Pixel Defect Policy

BRIGHT DOT DEFECTS	ACCEPTABLE LEVEL		
<i>MODEL</i>	192E2/192EL		
	2		
1 lit sub-pixel	3		
2 adjacent lit sub-pixels	1		
3 adjacent lit sub-pixels (one white pixel)	0		
Distance between two bright dots	15mm		
Bright dot defects within 20 mm circle	0		
Total bright dot defects of all type	3		

BLACK DOT DEFECTS	ACCEPTABLE LEVEL		
<i>MODEL</i>	192E2/192EL		
	2		
1 dark sub-pixel	5		
2 adjacent dark sub-pixels	2		
3 adjacent dark sub-pixels (one white pixel)	1		
Distance between two black dots	15mm		
Black dot defects within 20 mm circle*	1		
Total black dot defects of all type	5		

TOTAL DOT DEFECTS	ACCEPTABLE LEVEL		
<i>MODEL</i>	192E2/192EL		
	2		
Total bright or black dot defects of all type	5		

General Product Specification

Fig 1: Measurement locations of Brightness Uniformity

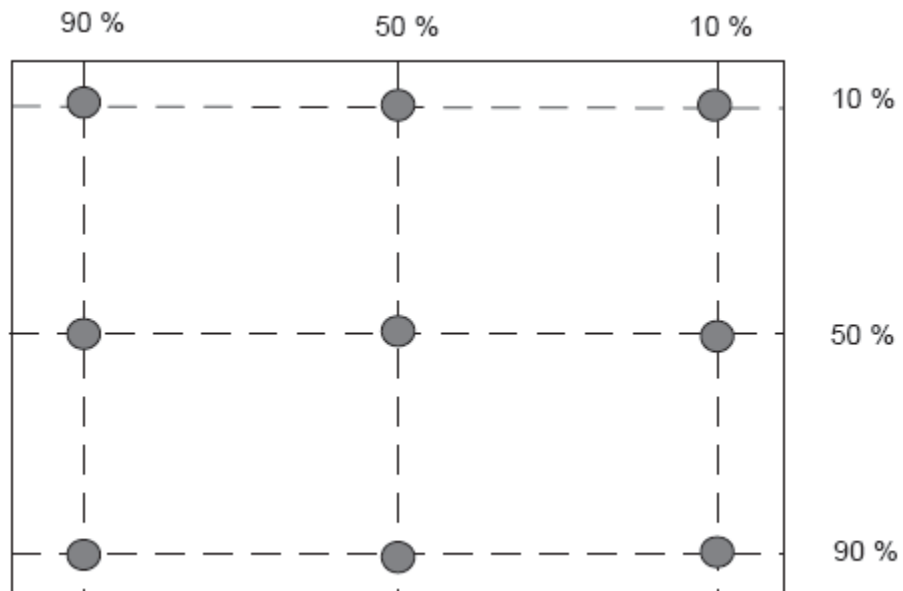

General Product Specification

Fig 2: Cross talk pattern
 Gray level 46 (64 Gray level)

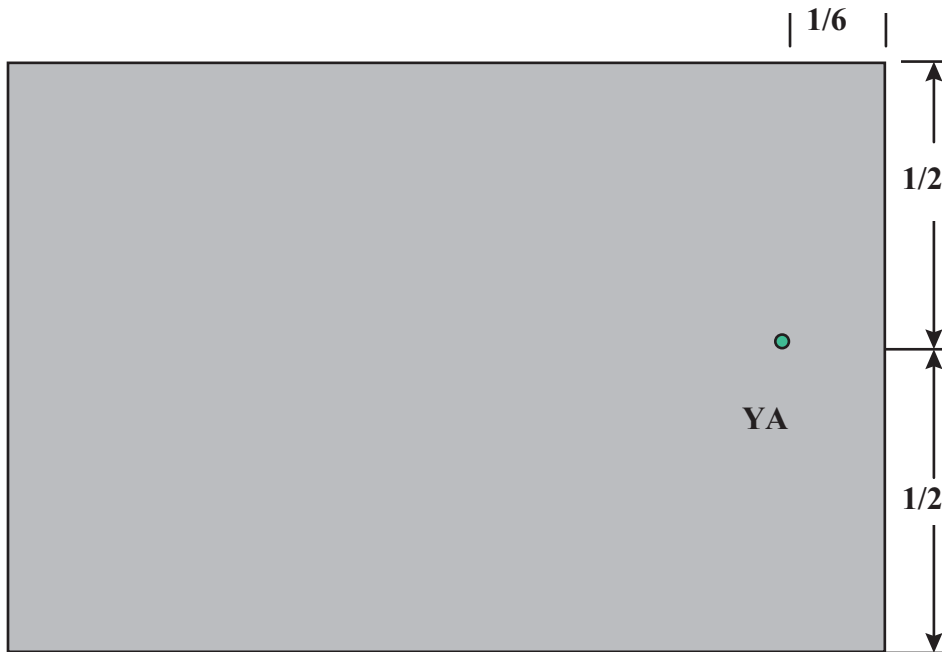
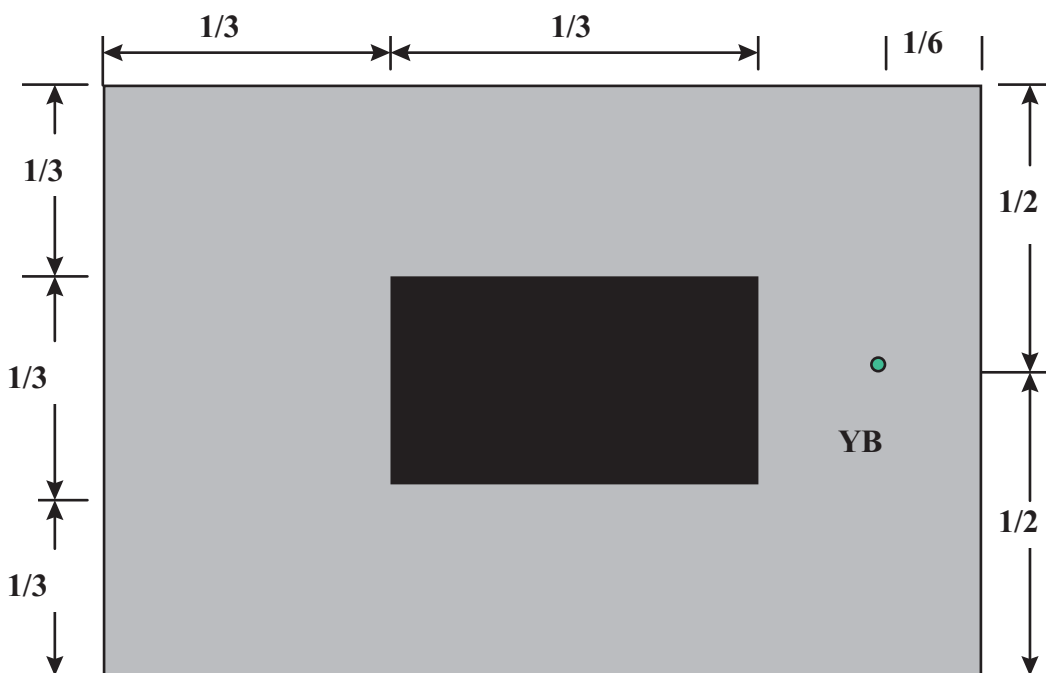

Fig 3: Cross talk Pattern
 Center at Gray level 0 (Black)



General Product Specification

REGULATORY COMPLIANCE

9.1 Worldwide Regulatory



TYE-A0004 LCD
Monitor Approbation

9.2 EMC Requirements

Supplier DVT EMI test result must be submitted prior to DVT samples delivery, and PVT EMI test result must be submitted again prior to PVT samples delivery, which also has to meet Philips' immunity testing specification.

9.3 RoHS

Restriction on the use of certain hazardous substances.

Lead, Cadmium, Mercury, Hexavalent Chromium, Polybrominated Biphenyl (PBB) and Polybrominated Biphenyl Ether (PBDE)(flame retardant).

9.4 WEEE

Producers (Philips) responsible for retailer take back schemes and recycling.

--System implemented.

--Collection and recycle targets.

9.5 Ongoing Regulatory

There's a possibility that other regulatory certificates will be required during the life of the product. It is the responsibility of the supplier to provide related documentation.

Exploded View

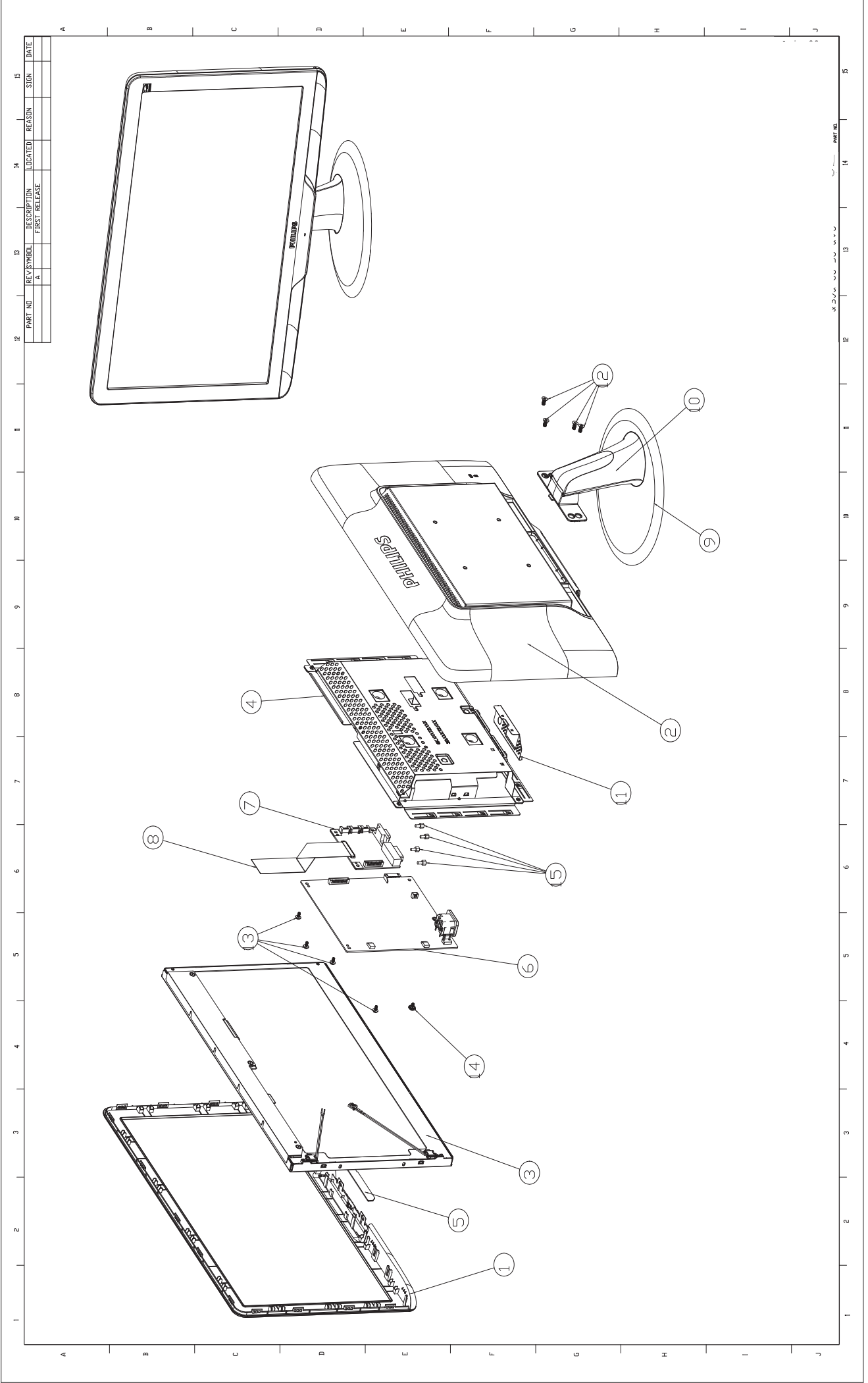

12	PART NO	REV/SYMBOL	DESCRIPTION	LOCATED	REASON	STOK	DATE
	A		FIRST RELEASE				

Spare / Recommended Parts List

Model:192E2

- ⊙ Spare parts change rule:
 Gray color: old parts can be ALT to new parts
 Gray color with delete line: old parts can not be used to this model
- ⊙ Spare parts upgrade rule: last number +1 -> Latest version parts number

Example old : 6K.0QC01.011 /
 new : 6K.0QC01.012

Panel+PCBA Styling		Model	192E2S000				192E2S010(EU)				192E2S010(AP)				192E2S002				192E2S027				192E2S027				192E2S000(AP)							
location	Description	PCM code	SEC	CMO	AUO	CPT	SEC	CMO	AUO	CPT	SEC	CMO	AUO	CPT	SEC	CMO	AUO	CPT	SEC	CMO	AUO	CPT	SEC	CMO	AUO	CPT	SEC	CMO	AUO	CPT	SEC	CMO	AUO	CPT
7	MAIN (IF) BOARD ASSY	5J.17N01.001	V	V	V	V	V	V	V	V	V	V	V	V	V	V	V	V	V	V	V	V	V	V	V	V	V	V	V	V	V	V	V	V
	MAIN (IF) BOARD ASSY (Analog)	5E.17N01.011	V	V	V	V	V	V	V	V	V	V	V	V	V	V	V	V	V	V	V	V	V	V	V	V	V	V	V	V	V	V	V	V
		5E.17N01.012	V	V	V	V	V	V	V	V	V	V	V	V	V	V	V	V	V	V	V	V	V	V	V	V	V	V	V	V	V	V	V	V
6	POWER BOARD ASSY	5E.17N02.001	V	V	V	V	V	V	V	V	V	V	V	V	V	V	V	V	V	V	V	V	V	V	V	V	V	V	V	V	V	V	V	V
		5E.17N02.002	V	V	V	V	V	V	V	V	V	V	V	V	V	V	V	V	V	V	V	V	V	V	V	V	V	V	V	V	V	V	V	V
5	CTRL BD ASSY	5E.17N03.001	V	V	V	V	V	V	V	V	V	V	V	V	V	V	V	V	V	V	V	V	V	V	V	V	V	V	V	V	V	V	V	V
	LCDM18W SEC LTM183A10TTP ZBD (SEC)	5F.LSHPP.001	V				V				V				V				V				V				V				V			
	LCDM18.5W M185B1-L02 P (CMO)	5F.LM8PP.011	V				V				V				V				V				V				V				V			
	LCDM18.5W M185XW01-VB Z (AUO)	5F.LUHVO.051	V				V				V				V				V				V				V				V			
3	LCDM185W CLAA185WA03 CPT P (CPT)	5F.LTHPP.011	V				V				V				V				V				V				V				V			
		5K.17N02.N01	V	V	V	V	V	V	V	V	V	V	V	V	V	V	V	V	V	V	V	V	V	V	V	V	V	V	V	V	V	V	V	V
8	FFC CABLE 30P 16TH	5K.17N02.N01	V	V	V	V	V	V	V	V	V	V	V	V	V	V	V	V	V	V	V	V	V	V	V	V	V	V	V	V	V	V	V	V

Mechanical Styling		Model	192E2S000				192E2S010(EU)				192E2S010(AP)				192E2S002				192E2S027				192E2S027				192E2S000(AP)							
location	Description	PCM code	SEC	CMO	AUO	CPT	SEC	CMO	AUO	CPT	SEC	CMO	AUO	CPT	SEC	CMO	AUO	CPT	SEC	CMO	AUO	CPT	SEC	CMO	AUO	CPT	SEC	CMO	AUO	CPT	SEC	CMO	AUO	CPT
9	BASE ASSY	6K.17N11.001	V	V	V	V	V	V	V	V	V	V	V	V	V	V	V	V	V	V	V	V	V	V	V	V	V	V	V	V	V	V	V	V
10	COLUMN ASSY	6K.17N10.001	V	V	V	V	V	V	V	V	V	V	V	V	V	V	V	V	V	V	V	V	V	V	V	V	V	V	V	V	V	V	V	V
1	FRONT BEZEL ASSY (Black)	6K.17N01.001	V	V	V	V	V	V	V	V	V	V	V	V	V	V	V	V	V	V	V	V	V	V	V	V	V	V	V	V	V	V	V	V
		6K.17N16.001	V	V	V	V	V	V	V	V	V	V	V	V	V	V	V	V	V	V	V	V	V	V	V	V	V	V	V	V	V	V	V	V
2	REAR COVER ASSY	6K.17N04.001	V	V			V	V			V	V			V	V			V	V			V	V			V	V			V	V		
		6K.17N02.001	V	V			V	V			V	V			V	V			V	V			V	V			V	V			V	V		
		6K.17N06.001	V	V			V	V			V	V			V	V			V	V			V	V			V	V			V	V		
		6K.17N05.001	V	V			V	V			V	V			V	V			V	V			V	V			V	V			V	V		
	REAR COVER ASSY (analog)	6K.17N03.001	V	V			V	V			V	V			V	V			V	V			V	V			V	V			V	V		
		6K.17N07.001	V	V			V	V			V	V			V	V			V	V			V	V			V	V			V	V		

Packing Styling		Model	192E2S000				192E2S010(EU)				192E2S010(AP)				192E2S002				192E2S027				192E2S027				192E2S000(AP)							
location	Description	PCM code	SEC	CMO	AUO	CPT	SEC	CMO	AUO	CPT	SEC	CMO	AUO	CPT	SEC	CMO	AUO	CPT	SEC	CMO	AUO	CPT	SEC	CMO	AUO	CPT	SEC	CMO	AUO	CPT	SEC	CMO	AUO	CPT
100	CUSHION FRONT	4G.17N02.001	V	V	V	V	V	V	V	V	V	V	V	V	V	V	V	V	V	V	V	V	V	V	V	V	V	V	V	V	V	V	V	V
		4G.17N06.001	V	V	V	V	V	V	V	V	V	V	V	V	V	V	V	V	V	V	V	V	V	V	V	V	V	V	V	V	V	V	V	V
		4G.17N04.001	V	V	V	V	V	V	V	V	V	V	V	V	V	V	V	V	V	V	V	V	V	V	V	V	V	V	V	V	V	V	V	V
110	CUSHION BACK	4G.17N08.001	V	V	V	V	V	V	V	V	V	V	V	V	V	V	V	V	V	V	V	V	V	V	V	V	V	V	V	V	V	V	V	V
		4G.17N03.001	V	V	V	V	V	V	V	V	V	V	V	V	V	V	V	V	V	V	V	V	V	V	V	V	V	V	V	V	V	V	V	V
		4G.17N07.001	V	V	V	V	V	V	V	V	V	V	V	V	V	V	V	V	V	V	V	V	V	V	V	V	V	V	V	V	V	V	V	V
120	CARTON	4G.17N09.001	V	V	V	V	V	V	V	V	V	V	V	V	V	V	V	V	V	V	V	V	V	V	V	V	V	V	V	V	V	V	V	V
		4D.17N01.001	V	V	V	V	V	V	V	V	V	V	V	V	V	V	V	V	V	V	V	V	V	V	V	V	V	V	V	V	V	V	V	V
		4D.17N01.002	V	V	V	V	V	V	V	V	V	V	V	V	V	V	V	V	V	V	V	V	V	V	V	V	V	V	V	V	V	V	V	V
		4D.17N02.001	V	V	V	V	V	V	V	V	V	V	V	V	V	V	V	V	V	V	V	V	V	V	V	V	V	V	V	V	V	V	V	V
		4D.17N02.002	V	V	V	V	V	V	V	V	V	V	V	V	V	V	V	V	V	V	V	V	V	V	V	V	V	V	V	V	V	V	V	V

Accessory Styling		Model	192E2S000				192E2S010(EU)				192E2S010(AP)				192E2S002				192E2S027				192E2S027				192E2S000(AP)							
location	Description	PCM code	SEC	CMO	AUO	CPT	SEC	CMO	AUO	CPT	SEC	CMO	AUO	CPT	SEC	CMO	AUO	CPT	SEC	CMO	AUO	CPT	SEC	CMO	AUO	CPT	SEC	CMO	AUO	CPT	SEC	CMO	AUO	CPT
200	OSG PHILIPS 192E2/192EL2	4J.17N01.001	V	V	V	V	V	V	V	V	V	V	V	V	V	V	V	V	V	V	V	V	V	V	V	V	V	V	V	V	V	V	V	V
210	CD PHILIPS 192E2/192EL2 EDFU	4J.17N01.002	V	V	V	V	V	V	V	V	V	V	V	V	V	V	V	V	V	V	V	V	V	V	V	V	V	V	V	V	V	V	V	V
		5B.17N01.002	V	V	V	V	V	V	V	V	V	V	V	V	V	V	V	V	V	V	V	V	V	V	V	V	V	V	V	V	V	V	V	V
30	CORD H05VV-3G 10A250V 1500 EUR	2G.02718.051	V	V	V	V	V	V	V	V	V	V	V	V	V	V	V	V	V	V	V	V	V	V	V	V	V	V	V	V	V	V	V	V
	<ALT>CORD H05VV-3G 10A250V 1500 EUR	2G.02718.05H	V	V	V	V	V	V	V	V	V	V	V	V	V	V	V	V	V	V	V	V	V	V	V	V	V	V	V	V	V	V	V	V
	CORD SVT125V W0/SH 1.5M US	2G.01111.031	V	V	V	V	V	V	V	V	V	V	V	V	V	V	V	V	V	V	V	V	V	V	V	V	V	V	V	V	V	V	V	V
	CORD H05VV-F 13A250V 1.5M UK	2G.03131.031	V	V	V	V	V	V	V	V	V	V	V	V	V	V	V	V	V	V	V	V	V	V	V	V	V	V	V	V	V	V	V	V
	CORD VCTF 2P W/G PSE 1.5M JAP	2G.03513.031	V	V	V	V	V	V	V	V	V	V	V	V	V	V	V	V	V	V	V	V	V	V	V	V	V	V	V	V	V	V	V	V
	CORD H05VV 250V 1.8M BLK INDIA	2G.04133.001	V	V	V	V	V	V	V	V	V	V	V	V	V	V	V	V	V	V	V	V	V	V	V	V	V	V	V	V	V	V	V	V
	CORD 3ASL/75DU-IN 250V1.5M AUS	2G.01343.031	V	V	V	V	V	V	V	V	V	V	V	V	V	V	V	V	V	V	V	V	V	V	V	V	V	V	V	V	V	V	V	V
<ALT>CORD 3ASL/75DU-IN 250V1.5M AUS	2G.01343.061	V	V	V	V	V	V	V	V	V	V	V	V	V	V	V	V	V	V	V	V	V	V	V	V	V	V	V	V	V	V	V	V	
CORD RVV300/500 10A25V1.5MM 3C	2G.03745.001	V	V	V	V	V	V	V	V	V	V	V	V	V	V	V	V	V	V	V	V	V	V	V	V	V	V	V	V	V	V	V	V	
<ALT>CORD RVV300/500 10A25V1.5MM	2G.03745.00H	V	V	V	V	V	V	V	V	V	V	V	V	V	V	V	V	V	V	V	V	V	V	V	V	V	V	V	V	V	V	V	V	
CORD VCTF 7A 125V 1.5M CNS-TW	2G.04811.021	V	V	V	V	V	V	V	V	V	V	V	V	V	V	V	V	V	V	V	V	V	V	V	V	V	V	V	V	V	V	V	V	
31	CABLE SIGNAL/C H+V OD 5.5 1.8M	5K.L2H06.501	V	V	V	V	V	V	V	V	V	V	V	V	V	V	V	V	V	V	V	V	V	V	V	V	V	V	V	V	V	V	V	V

Critical components		Model	192E2S000				192E2S010(EU)				192E2S010(AP)				192E2S002				192E2S027				192E2S027				192E2S000(AP)			
location	Description	PCM code	SEC	CMO	AUO	CPT	SEC	CMO	AUO	CPT	SEC	CMO	AUO	CPT																

Spare / Recommended Parts List

Model:192E2

☉ Spare parts change rule:

Gray color: old parts can be ALT to new parts

Gray color with delete line: old parts can not be used to this model

☉ Spare parts upgrade rule: last number +1 -> Latest version parts number

Example old : 6K.QC01.011 /
new : 6K.QC01.012

Panel+PCBA Styling		Model	192E2SB01				192E2SB07				192E2SB06				192E2SB96				192E2SB96				192E2SB96															
location	Description	PCM code	SEC	CMO	AUO	CPT	SEC	CMO	AUO	CPT	SEC	CMO	AUO	CPT	SEC	CMO	AUO	CPT	SEC	CMO	AUO	CPT	SEC	CMO	AUO	CPT	SEC	CMO	AUO	CPT	SEC	CMO	AUO	CPT				
7	MAIN (IF) BOARD ASSY	5E.17N01.001	V	V	V	V	V	V	V	V	V	V	V	V	V	V	V	V	V	V	V	V	V	V	V	V	V	V	V	V	V	V	V	V	V	V	V	V
	MAIN (IF) BOARD ASSY (Analog)	5E.17N01.011																																				
		5E.17N01.012																																				
6	POWER BOARD ASSY	5E.17N02.001	V	V	V	V	V	V	V	V	V	V	V	V	V	V	V	V	V	V	V	V	V	V	V	V	V	V	V	V	V	V	V	V	V	V	V	V
		5E.17N02.002																																				
3	CTRL BD ASSY	5E.17N03.001	V	V	V	V	V	V	V	V	V	V	V	V	V	V	V	V	V	V	V	V	V	V	V	V	V	V	V	V	V	V	V	V	V	V	V	V
	LCDM18W SEC LTM183A10TP ZBD (SEC)	5F.LM8PP.001	V				V				V				V				V				V				V				V				V			
	LCDM18.5W M185B1-L02 P (CMO)	5F.LM8PP.011		V				V				V				V				V				V				V				V				V		
	LCDM18.5W M185XW01-VB Z (AUO)	5F.LUHVO.051			V				V				V				V				V				V				V				V				V	
8	LCDM185W CLAA185WA03 CPT P (CPT)	5F.LTHPP.011																																				
	FFC CABLE 30P 16TH	5K.17N02.N01	V	V	V	V	V	V	V	V	V	V	V	V	V	V	V	V	V	V	V	V	V	V	V	V	V	V	V	V	V	V	V	V	V	V	V	V

Mechanical Styling		Model	192E2SB01				192E2SB07				192E2SB06				192E2SB96				192E2SB96				192E2SB96															
location	Description	PCM code	SEC	CMO	AUO	CPT	SEC	CMO	AUO	CPT	SEC	CMO	AUO	CPT	SEC	CMO	AUO	CPT	SEC	CMO	AUO	CPT	SEC	CMO	AUO	CPT	SEC	CMO	AUO	CPT	SEC	CMO	AUO	CPT				
9	BASE ASSY	6K.17N11.001	V	V	V	V	V	V	V	V	V	V	V	V	V	V	V	V	V	V	V	V	V	V	V	V	V	V	V	V	V	V	V	V	V	V	V	V
10	COLUMN ASSY	6K.17N10.001	V	V	V	V	V	V	V	V	V	V	V	V	V	V	V	V	V	V	V	V	V	V	V	V	V	V	V	V	V	V	V	V	V	V	V	V
1	FRONT BEZEL ASSY (Black)	6K.17N01.001	V	V	V	V	V	V	V	V	V	V	V	V	V	V	V	V	V	V	V	V	V	V	V	V	V	V	V	V	V	V	V	V	V	V	V	V
		6K.17N16.001		V				V				V				V				V				V				V				V				V		
2	REAR COVER ASSY	6K.17N04.001	V	V	V	V	V	V	V	V	V	V	V	V	V	V	V	V	V	V	V	V	V	V	V	V	V	V	V	V	V	V	V	V	V	V	V	V
		6K.17N02.001			V				V				V				V				V				V				V				V				V	
		6K.17N06.001				V				V				V				V				V				V				V				V				
	REAR COVER ASSY (analog)	6K.17N05.001																																				
		6K.17N03.001																																				
		6K.17N07.001																																				

Packing Styling		Model	192E2SB01				192E2SB07				192E2SB06				192E2SB96				192E2SB96				192E2SB96															
location	Description	PCM code	SEC	CMO	AUO	CPT	SEC	CMO	AUO	CPT	SEC	CMO	AUO	CPT	SEC	CMO	AUO	CPT	SEC	CMO	AUO	CPT	SEC	CMO	AUO	CPT	SEC	CMO	AUO	CPT	SEC	CMO	AUO	CPT				
100	CUSHION FRONT	4G.17N02.001	V	V	V	V	V	V	V	V	V	V	V	V	V	V	V	V	V	V	V	V	V	V	V	V	V	V	V	V	V	V	V	V	V	V	V	V
		4G.17N06.001																																				
		4G.17N04.001																																				
110	CUSHION BACK	4G.17N08.001	V	V	V	V	V	V	V	V	V	V	V	V	V	V	V	V	V	V	V	V	V	V	V	V	V	V	V	V	V	V	V	V	V	V	V	V
		4G.17N03.001																																				
		4G.17N07.001																																				
120	CARTON	4G.17N09.001																																				
		4D.17N01.001																																				
		4D.17N01.002																																				
		4D.17N02.001																																				
		4D.17N02.002																																				

Accessory Styling		Model	192E2SB01				192E2SB07				192E2SB06				192E2SB96				192E2SB96				192E2SB96															
location	Description	PCM code	SEC	CMO	AUO	CPT	SEC	CMO	AUO	CPT	SEC	CMO	AUO	CPT	SEC	CMO	AUO	CPT	SEC	CMO	AUO	CPT	SEC	CMO	AUO	CPT	SEC	CMO	AUO	CPT	SEC	CMO	AUO	CPT				
200	QSG PHILIPS 192E2/192EL2	4J.17N01.001	V	V	V	V	V	V	V	V	V	V	V	V	V	V	V	V	V	V	V	V	V	V	V	V	V	V	V	V	V	V	V	V	V	V	V	V
210	CD PHILIPS 192E2/192EL2 EDFU	4J.17N01.002	V	V	V	V	V	V	V	V	V	V	V	V	V	V	V	V	V	V	V	V	V	V	V	V	V	V	V	V	V	V	V	V	V	V	V	V
		5B.17N01.002	V	V	V	V	V	V	V	V	V	V	V	V	V	V	V	V	V	V	V	V	V	V	V	V	V	V	V	V	V	V	V	V	V	V	V	V
30	CORD H05VV-3G 10A250V 1500 EUR	2G.02718.051	V	V	V	V	V	V	V	V	V	V	V	V	V	V	V	V	V	V	V	V	V	V	V	V	V	V	V	V	V	V	V	V	V	V	V	V
	<ALT>CORD H05VV-3G 10A250V 1500 EUR	2G.02718.05H	V	V	V	V	V	V	V	V	V	V	V	V	V	V	V	V	V	V	V	V	V	V	V	V	V	V	V	V	V	V	V	V	V	V	V	V
	CORD SVT125V WD/SH 1.5M US	2G.01111.031																																				
	CORD H05VV-F 13A250V 1.5M UK	2G.03131.031																																				
	CORD VCTF 2P W/G PSE 1.5M JAP	2G.03513.031																																				
	CORD H05VV 250V 1.8M BLK INDIA	2G.04133.001																																				
	CORD 3ASL/75DU-IN 250V1.5M AUS	2G.01343.031																																				
	<ALT>CORD 3ASL/75DU-IN 250V1.5M AUS	2G.01343.061																																				
CORD RVV300/500 10A25V1.5MM 3C	2G.03745.001																																					
<ALT>CORD RVV300/500 10A25V1.5MM 3C	2G.03745.00H																																					
CORD VCTF 7A 125V 1.5M CNS-TW	2G.04811.021																																					
31	CABLE SIGNAL/C H+V OD 5.5 1.8M	5K.L2H06.501	V	V	V	V	V	V	V	V	V	V	V	V	V	V	V	V	V	V	V	V	V	V	V	V	V	V	V	V	V	V	V	V	V	V	V	V

Critical components		Model	192E2SB01				192E2SB07				192E2SB06				192E2SB96				192E2SB96				192E2SB96											
location	Description	PCM code	SEC	CMO	AUO	CPT	SEC	CMO	AUO	CPT	SEC	CMO	AUO	CPT	SEC	CMO	AUO	CPT	SEC	CMO	AUO	CPT	SEC	CMO	AUO	CPT	SEC	CMO	AUO	CPT	SEC	CMO	AUO	CPT
IC801	IC SR STR-W6262 T0220-6P</																																	

Panel & PCBA photos

ITEM	PCM	Description	Photo
1	5F.LSHPP.001	LCDM19W SEC LTM185AT01 P ZBD (SEC)	
2	5F.LM8PP.011	LCDM18.5W M185B1-L02 P (CMO)	
3	5E.17N01.001	MAIN (I/F) BOARD ASS'Y	
4	5E.17N02.001	POWER BOARD ASS'Y	
5	5E.17N03.001	CTRL BD ASS'Y	

Repair Tips

0. Warning

All ICs and many other semi-conductors are susceptible to electrostatic discharges (ESD). Careless handling during repair can reduce life drastically. When repairing, make sure that you are connected with the same potential as the mass of the unit via a wrist wrap with resistance. Keep components and tools also at the same potential!

1. Servicing of SMDs (Surface Mounted Devices)

1.1 General cautions on handling and storage

- Oxidation on the terminals of SMDs results in poor soldering. Do not handle SMDs with bare hands.
 - Avoid using storage places that are sensitive to oxidation such as places with sulphur or chlorine gas, direct sunlight, high temperatures or a high degree of humidity. The capacitance or resistance value of the SMDs may be affected by this.
 - Rough handling of circuit boards containing SMDs may cause damage to the components as well as the circuit boards. Circuit boards containing SMDs should never be bent or flexed. Different circuit board materials expand and contract at different rates when heated or cooled and the components and/or solder connections may be damaged due to the stress. Never rub or scrape chip components as this may cause the value of the component to change.
- Similarly, do not slide the circuit board across any surface.

1.2 Removal of SMDs

- Heat the solder (for 2-3 seconds) at each terminal of the chip. By means of litz wire and a slight horizontal force, small components can be removed with the soldering iron.
- They can also be removed with a solder sucker (see Fig. 1A)

Fig. 1 DISMOUNTING

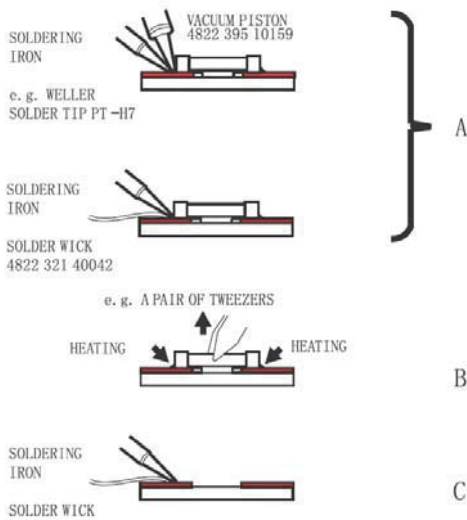

While holding the SMD with a pair of tweezers, take it off gently using the soldering iron's heat applied to each terminal (see Fig. 1 B).
 - Remove the excess solder on the solder lands by means of litz wire or a solder sucker (see Fig. 1C).

While holding the SMD with a pair of tweezers, take it off gently using the soldering iron's heat applied to each terminal (see Fig. 1 B).
 - Remove the excess solder on the solder lands by means of litz wire or a solder sucker (see Fig. 1C).

1.3 Caution on removal

- When handling the soldering iron, use suitable pressure and be careful.
- When removing the chip, do not use undue force with the pair of tweezers.
- The soldering iron to be used (approx. 30 W) should preferably be equipped with a thermal control (soldering temperature: 225 to 250 C).
- The chip, once removed, must never be reused.

1.4 Attachment of SMDs

- Locate the SMD on the solder lands by means of tweezers and solder the component on one side. Ensure that the component is positioned correctly on the solder lands (see Fig.2A).
- Next complete the soldering of the terminals of the component (see Fig. 2B).

Fig. 2 MOUNTING

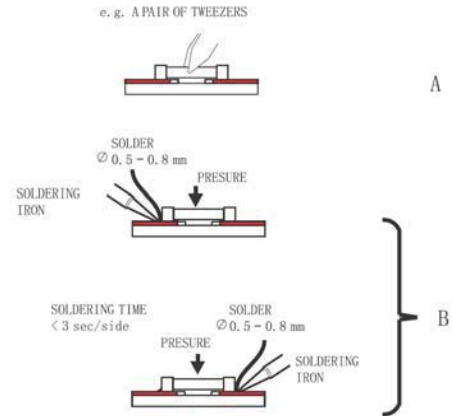

2. Caution when attaching SMDs

- When soldering the SMD terminals, do not touch them directly with the soldering iron. The soldering should be done as quickly as possible, care must be taken to avoid damage to the terminals of the SMDs themselves.
- Keep the SMD's body in contact with the printed board when soldering.
- The soldering iron to be used (approx. 30 W) should preferably be equipped with a thermal control (soldering temperature: 225 to 250 C).
- Soldering should not be done outside the solder land.
- Soldering flux (of rosin) may be used, but should not be acidic.
- After soldering, let the SMD cool down gradually at room temperature.
- The quantity of solder must be proportional to the size of the solder land. If the quantity is too great, the SMD might crack or the solder lands might be torn loose from the printed board (see Fig. 3).

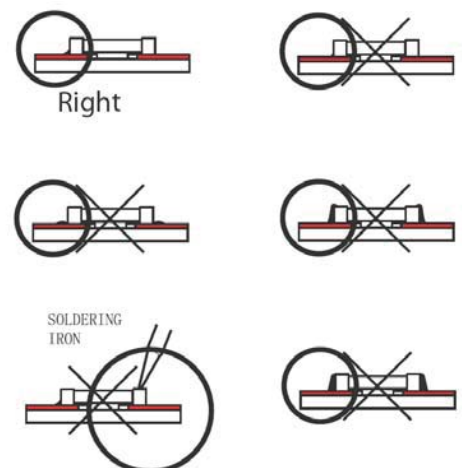

Fig.3 Examples

Repair Tips

3. Lead-free product identification

You can identify lead-free product by Philips-lead-free logo on PCB.



4. Lead-free product repair instruction

4.1 Use only lead-free Solder Alloy 0622 149 00106(1.2mm SAC305) or 0622 14900108(1.0mm SAC305).

Remark: For lead free soldering material, please visit www.alphametals.com website for details. This is recommended by Philips.

4.2 Use only adequate solder tools applicable for lead-free soldering-tin. The solder tool must be able to reach at least a solder-temperature of 400, to stabilize the adjusted temperature at the solder-tip and to exchange solder-tips for different applications.

Small Passives/Actives to be removed with thermal tweezers

Automated system for IC and BGA repair (Microscope, Camera, Beam split optics, Computer, Programmer, Heat controllers, Vacuum system, Laser pointer) Solder Hand-Tool (Adjustable in temperature height, Temperature shall be held constant, Flexible tips)

4.3 Adjust your solder tool so that a temperature around 360 -380 is reached and stabilized at the solder joint.

Heating-time of the solder-joint should not exceed ~ 4 sec. Avoid temperatures above 400 otherwise wear-out of tips will rise drastically and flux-fluid will be destroyed. Corrosion of Tool-Spikes can be avoided when using SAC305 and a temperature of less than 400.

4.4 Mix of lead-free solder-tin/parts with leaded soldering-tin/parts is possible but not recommended. If not to avoid clean carefully the solder-joint from old tin and re-solder with new tin.

4.5 Use only original spare-parts listed in the Service-Manuals. Standard-material (consumables) can also be purchased at external companies.

4.6 Special information for lead-free BGA-ICs: this ICs will be delivered in so-called dry-packaging to protect the IC against moisture and with lead-free logo on it. This packaging may only be opened shortly before it is used (soldered). Otherwise the body of the IC gets wet inside and during the heating time the structure of the IC will be destroyed due to high (steam-) pressure. If the packaging was opened before usage the IC has to be heated up for some hours (around 90) for drying (Take attention for ESD-protection!)

5. Rework on BGA (Ball Grid Array) ICs

General

Although (LF)BGA assembly yields are very high, there may still be a requirement for component rework. By rework, we mean the process of removing the component from the PWB and replacing it with a new component. If an (LF) BGA is removed from a PWB, the solder balls of the component are deformed drastically so the removed (LF)BGA has to be discarded.

Device Removal

As is the case with any component that, it is essential when removing an (LF) BGA, the board, tracks, solder lands, or surrounding components are not damaged. To remove an (LF)BGA, the board must be uniformly heated to a temperature close to the reflow soldering temperature. A uniform temperature reduces the chance of warping the PWB.

To do this, we recommend that the board is heated until it is certain that all the joints are molten. Then carefully pull the component off the board with a vacuum nozzle. For the appropriate temperature profiles, see the IC data sheet.

Area Preparation

When the component has been removed, the vacant IC area must be cleaned before replacing the (LF) BGA. Removing an IC often leaves varying amounts of solder on the mounting lands. This excessive solder can be removed with either a solder sucker or solder wick. The remaining flux can be removed with a brush and cleaning agent. After the board is properly cleaned and inspected, apply flux on the solder lands and on the connection balls of the (LF)BGA

Note: Do not apply solder paste, as this has shown to result in problems during re-soldering.

Device Replacement

The last step in the repair process is to solder the new component on the board. Ideally, the (LF) BGA should be aligned under a microscope or magnifying glass. If this is not possible, try to align the (LF)BGA with any board markers. To reflow the solder, apply a temperature profile according to the IC data sheet. So as not to damage neighbouring components, it may be necessary to reduce some temperatures and times.

More Information

For more information on how to handle BGA devices, visit this URL: <http://www.atyourservice.ce.philips.com> (needs subscription). After login, select Magazine, then go to Workshop Information. Here you will find Information on how to deal with BGA-ICs.

Repair Flow Chart

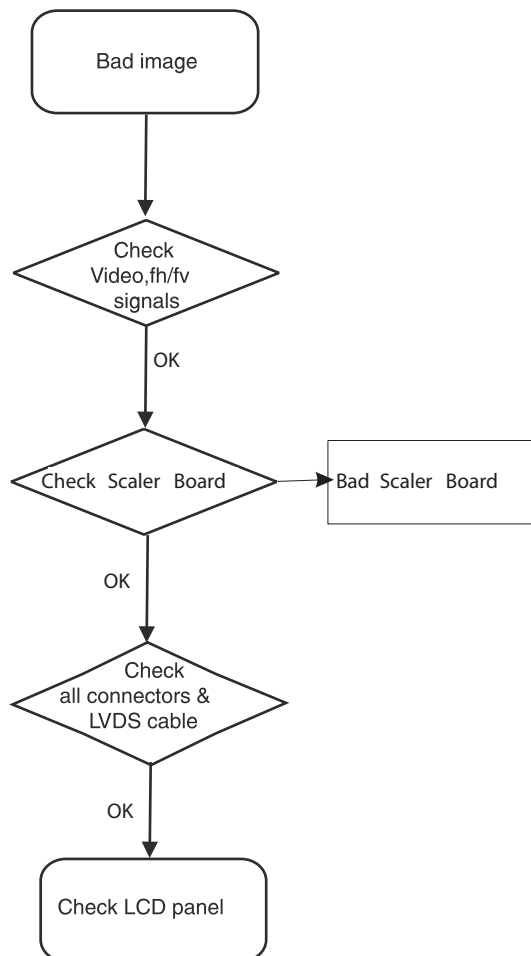
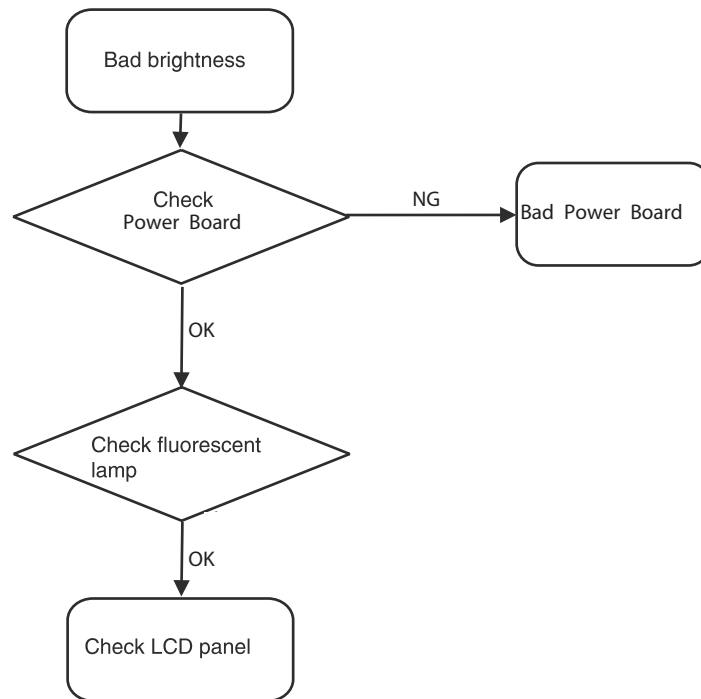

Repair Flow Chart

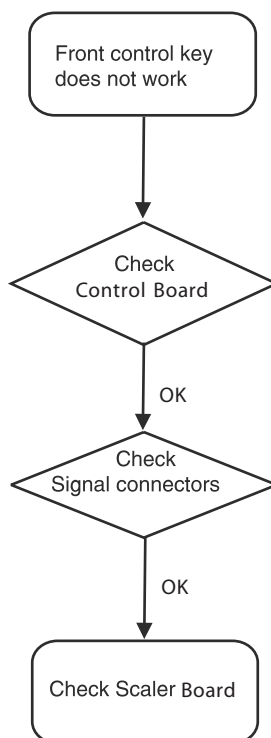
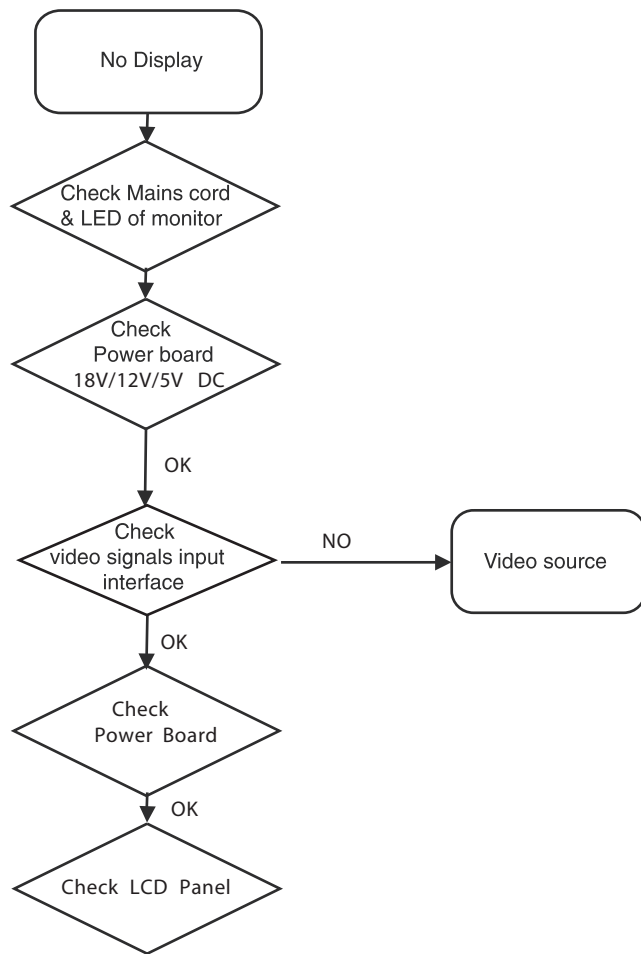

Safety Test Requirements

All units that are returned for service or repair must pass the original manufactures safety tests. Safety testing requires both Hipot and Ground Continuity testing.

HI-POT TEST INSTRUCTION

1. Application requirements

- 1.1 All mains operated products must pass the Hi-Pot test as described in this instruction.
- 1.2 This test must be performed again after the covers have been refitted following the repair , inspection or modification of the product.

2. Test method

2.1 Connecting conditions

- 2.1.1 The test specified must be applied between the parallel blade plug of the main scord and all accessible metal parts of the product.
- 2.1.2 Before carrying out the test, reliable conductive connections must be ensured and thereafter be maintained throughout the test period.
- 2.1.3 The mains switch(es) must be in the "ON" position.

2.2 Test Requirements

All products should be HiPot and Ground Continuity tested as follows:

Condition	Hi-Pot Test for products where the mains input is 220V AC	Hi-Pot Test for products where the mains input is 110V AC	Ground Continuity Test requirement
Test voltage	2820VDC (2000VAC)	1700VDC (1200VAC)	Test current: 25A, AC Test time: 3 seconds
Test time	3 seconds	1 seconds	Resistance required: $\leq 0.09 + R_{ohm}$, R is the resistance of the mains cord.
Trip current (Tester)	Set at 100uA for Max limit; Set at 0.1uA for Min limit.	5mA	91 220CW9 LCD
Ramp time (Tester)	Set at 2 seconds	Xij	

- 2.2.1 The minimum test duration for Quality Control Inspector must be 1 minute.
- 2.2.2 The test voltage must be maintained within the specified voltage + 5%.
- 2.2.3 There must be no breakdown during the test.
- 2.2.4 The grounding blade or pin of mains plug must be conducted with accessible metal parts.

3. Equipments and Connection

3.1. Equipments

For example :

- Zentech 9032 PROGRAMMABLE AUTO SAFETY TESTER

3.2. Connection

* Turn on the power switch of monitor before Hipot and Ground Continuity testing.



(Zentech 9032 tester)

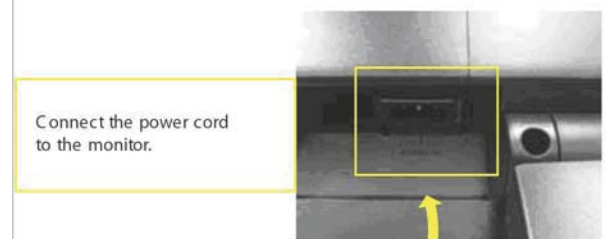

Power outlet
(Rear view of monitor)

4. Recording

Hipot and Ground Continuity testing records have to be kept for a period of 10 years.