

Service
Service
Service



191E2SB/00	191EL2SB/00	191EL2SB/67
191E2SB/10	191EL2SB/10	191EL2SB/70
191E2SB/27	191EL2SB/27	191EL2SB/55
191E2SB/62	191EL2SB/69	191EL2SB/01
191E2SB/69	191EL2SB/71	
191E2SB/71	191EL2SB/75	
191E2SB/73	191EL2SB/78	
191E2SB/75	191EL2SB/93	
191E2SB/93	191EL2SB/94	
191E2SB/94	191EL2SB/96	



Service Manual

Description	Page	Description	Page
Table of Contents.....	1	6.3 Inverter Board.....	29
Revision List.....	2	6.4 Converter Board.....	30
Important Safety Notice.....	3	6.5 Key Board.....	33
1. Monitor Specifications.....	4	7. PCB Layout.....	34
2. LCD Monitor Description.....	7	7.1 Scaler Board.....	34
3. Operation Instructions.....	9	7.2 Adapter Board.....	36
3.1 General Instructions.....	9	7.3 Inverter Board.....	37
3.2 Control Buttons.....	9	7.4 Converter Board.....	38
3.3 OSD Menu.....	10	7.5 Key Board.....	41
4. Input/output Specification.....	11	8. Wiring Diagram.....	42
4.1 Input Signal Connector.....	11	9. Scaler Board Overview.....	43
4.2 Resolution & Preset Modes.....	12	10. Mechanical Instructions.....	44
4.3 Pixel Defect Policy.....	13	11. Repair Flow Chart.....	47
4.4 Failure Mode of Panel.....	15	12. ISP Instructions.....	51
5. Block Diagram.....	16	13. DDC Instructions.....	58
5.1 Scaler Board.....	16	14. White Balance, Luminance Adjustment.....	71
5.2 Power Board.....	18	15. Monitor Exploded View.....	73
6. Schematic Diagram.....	19	16. Recommended & Spare Parts List.....	74
6.1 Scaler Board.....	28	17. Different Parts List.....	88
6.2 Adapter Board.....	28	18. General Product Specification.....	93

SAFETY NOTICE

ANY PERSON ATTEMPTING TO SERVICE THIS CHASSIS MUST FAMILIARIZE HIMSELF WITH THE CHASSIS AND BE AWARE OF THE NECESSARY SAFETY PRECAUTIONS TO BE USED WHEN SERVICING ELECTRONIC EQUIPMENT CONTAINING HIGH VOLTAGES.

CAUTION: USE A SEPARATE ISOLATION TRANSFORMER FOR THIS UNIT WHEN SERVICING

REFER TO BACK COVER FOR IMPORTANT SAFETY GUIDELINES

Revision List

Version	Release Date	Revision History
A00	Mar.31,2010	Initial release, Draft Version
A01	May.04,2010	Update BOM for 191EL2SB/00 and 191E2SB/69
		Update Monitor Specifications, Operating Instructions and Resolution & Preset Modes
A02	May.22,2010	Add AUO panel for 191EL2SB/69 and update BOM for 191EL2SB/96
A03	Jun.26,2010	Add CTN model 191EL2SB/71
		Add CPT and TPV panel for 191EL2SB/00
		Update BOM for 191E2SB/00, 191EL2SB/75 and 191EL2SB/93
A04	Aug.16,2010	Update BOM for 191E2SB/62
		Add CTN model 191EL2SB/78
		Add CPT and TPV panel for 191EL2SB/71
		Update BOM of TPV panel for 191EL2SB/00, 191EL2SB/69
A05	Sep.19,2010	Update BOM for 191EL2SB/00, 191EL2SB/69, 191EL2SB/71, 191EL2SB/75 and 191EL2SB/96
A06	Oct.19,2010	Add CTN models 191EL2SB/67 and 191EL2SB/70
		Add AUO VD panel for 191EL2SB/75
A07	Dec.20,2010	Add AUO VD panel for 191EL2SB /00, 191EL2SB/69, 191EL2SB/70, 191EL2SB/71, 191EL2SB/93, 191EL2SB/94 and 191EL2SB/96 (1A+1D)
		Lead into the new coverter board (pcb:715G4137P01000004S) for AUO panel
A08	Apr.18,2011	Add TPV panel for 191EL2SB/93
A09	May.12,2011	Add Auto Color SOP into ISP Instructions
		Update BOM for 191E2SB/62 and add CPT panel for 191EL2SB/94
A10	Jul.07,2011	Add CTN model 191EL2SB/55
A11	Sep.22,2011	Add CTN model 191EL2SB/01
		Update BOM for 191EL2 all models
		Lead into the new scaler board (pcb: 715G4411M01000004I) and converter board (pcb: 715G4704P01001004I) for AUO VDT0, SEC and CPT0 panel

Important Safety Notice

Proper service and repair is important to the safe, reliable operation of all Philips Company Equipment. The service procedures recommended by Philips and described in this service manual are effective methods of performing service operations. Some of these service operations require the use of tools specially designed for the purpose. The special tools should be used when and as recommended.

It is important to note that this manual contains various CAUTIONS and NOTICES which should be carefully read in order to minimize the risk of personal injury to service personnel. The possibility exists that improper service methods may damage the equipment. It is also important to understand that these CAUTIONS and NOTICES ARE NOT EXHAUSTIVE. Philips could not possibly know, evaluate and advise the service trade of all conceivable ways in which service might be done or of the possible hazardous consequences of each way. Consequently, Philips has not undertaken any such broad evaluation. Accordingly, a customer who uses a service procedure or tool which is not recommended by Philips must first satisfy himself thoroughly that neither his safety nor the safe operation of the equipment will be jeopardized by the service method selected.

Hereafter throughout this manual, Philips Company will be referred to as Philips.

WARNING

Use of substitute replacement parts, which do not have the same, specified safety characteristics, may create shock, fire, or other hazards.

Under no circumstances should the original design be modified or altered without written permission from Philips. Philips assumes no liability, express or implied, arising out of any unauthorized modification of design.

FOR PRODUCTS CONTAINING LASER:

DANGER- There is invisible laser radiation when open. AVOID DIRECT EXPOSURE TO BEAM.

CAUTION-Use of controls or adjustments or performance of procedures other than those specified herein may result in hazardous radiation exposure.

CAUTION -The use of optical instruments with this product will increase eye hazard.

TO ENSURE THE CONTINUED RELIABILITY OF THIS PRODUCT, USE ONLY ORIGINAL MANUFACTURER'S REPLACEMENT PARTS, WHICH ARE LISTED WITH THEIR PART NUMBERS IN THE PARTS LIST SECTION OF THIS SERVICE MANUAL.

Take care during handling the LCD module with backlight unit:

- Must mount the module using mounting holes arranged in four corners.
- Do not press on the panel, edge of the frame strongly or electric shock as this will result in damage to the screen.
- Do not scratch or press on the panel with any sharp objects, such as pencil or pen as this may result in damage to the panel.
- Protect the module from the ESD as it may damage the electronic circuit (C-MOS).
- Make certain that treatment person's body is grounded through wristband.
- Do not leave the module in high temperature and in areas of high humidity for a long time.
- Avoid contact with water as it may a short circuit within the module.
- If the surface of panel becomes dirty, please wipe it off with a soft material. (Cleaning with a dirty or rough cloth may damage the panel.)

1. Monitor Specifications

Technical specifications

Picture/Display			
LCD Panel Type	TFT-LCD		
Backlight	CCFL (191E2) / LED (191EL2)		
Panel Size	18.5" W (47cm)		
Aspect Ratio	16:9		
Pixel Pitch	0.300 x 0.300 mm		
Brightness	250 cd/m ²		
SmartContrast	500,000:1 (191E2) / 20,000,000:1 (191EL2)		
Contrast Ratio (typ.)	1000:1		
Response Time (typ.)	5 ms		
Optimum Resolution	1366 x 768 @ 60Hz		
Viewing Angle	176° (H) / 170° (V) @ C/R>5		
Picture Enhancement	SmartImage Lite		
Display Colors	16.7 M		
Vertical Refresh Rate	56Hz - 76Hz		
Horizontal Frequency	30kHz - 83kHz		
sRGB	YES		
Connectivity			
Signal Input	DVI-D (Digital, HDCP),VGA (Analog)		
Input Signal	Separate Sync, Sync on Green		
Convenience			
User Convenience	SmartImage/▼ ,Input/▲ , 4:3 Wide/Back, Menu (OK), Power On/Off		
OSD Languages	English, French, German, Italian, Russian, Spanish, Simplified Chinese, Portuguese		
Other Convenience	Kensington lock		
Plug & Play Compatibility	DDC/CI, sRGB, Windows 7/Vista/XP, Mac OSX, Linux		
Stand			
Tilt	-3 / +12 (191E2/191EL2)		
Power (191E2)			
On mode	21.4 W (typ.)		
Energy Consumption (EnergyStar 5.0 test method)	AC Input Voltage at 100VAC +/- 5VAC, 50Hz +/- 3Hz	AC Input Voltage at 115VAC +/- 5VAC, 60Hz +/- 3Hz	AC Input Voltage at 230VAC +/- 5VAC, 50Hz +/- 3Hz
Normal Operation (typ.)	16.33 W	16.32 W	16.30 W
Sleep	0.43 W	0.42 W	0.43 W
Off	0.42 W	0.42 W	0.43 W

Heat Dissipation*	AC Input Voltage at 100VAC +/- 5VAC, 50Hz +/- 3Hz	AC Input Voltage at 115VAC +/- 5VAC, 60Hz +/- 3Hz	AC Input Voltage at 230VAC +/- 5VAC, 50Hz +/- 3Hz
Normal Operation	68.33 BTU/hr	68.29 BTU/hr	68.20 BTU/hr
Sleep	1.47 BTU/hr	1.43 BTU/hr	1.47 BTU/hr
Off	1.43 BTU/hr	1.43 BTU/hr	1.47 BTU/hr
Power (191EL2)			
On mode	13.9W (typ.)		
Energy Consumption (EnergyStar 5.0 test method)	AC Input Voltage at 100VAC +/- 5VAC, 50Hz +/- 3Hz	AC Input Voltage at 115VAC +/- 5VAC, 60Hz +/- 3Hz	AC Input Voltage at 230VAC +/- 5VAC, 50Hz +/- 3Hz
Normal Operation (typ.)	10.49 W	10.50 W	10.44 W
Sleep	0.43 W	0.42 W	0.41 W
Off	0.42 W	0.42 W	0.40 W
Heat Dissipation*	AC Input Voltage at 100VAC +/- 5VAC, 50Hz +/- 3Hz	AC Input Voltage at 115VAC +/- 5VAC, 60Hz +/- 3Hz	AC Input Voltage at 230VAC +/- 5VAC, 50Hz +/- 3Hz
Normal Operation	43.89 BTU/hr	43.93 BTU/hr	43.68 BTU/hr
Sleep	1.47 BTU/hr	1.43 BTU/hr	1.71 BTU/hr
Off	1.43 BTU/hr	1.43 BTU/hr	1.67 BTU/hr
Power LED indicator	On mode: White, Standby/Sleep mode: White (blinking)		
Power Supply	AC Adapter, 1.2V==3.0A		
Dimension			
Product with Stand (W x H x D)	457 x 338 x 189 mm		
Product without Stand (W x H x D)	457 x 293 x 41 mm		
Box Dimension (W x H x D)	503 x 383 x 125 mm		
Weight			
Product with Stand	2.38 kg		
Product without Stand	2.22 kg		
Product with Packaging	3.58 kg		
Operating Condition			
Temperature Range (operation)	0°C to 40 °C		
Temperature Range (storage)	-20°C to 60°C		
Relative Humidity	20% to 80%		
Altitude	Non-operation: +12,000 ft (3,658 m)		
	Operation: + 40,000 ft (12,192 m)		
MTBF	50,000 hrs (191E2) / 30,000hrs (191EL2)		

6 Meridian 2

Environmental	
ROHS	YES
EPEAT	Silver. (www.epeat.net)
Packaging	100% recyclable
Compliance and standards	
Regulatory Approvals	CE Mark, FCC Class B, SEMKO, TÜV/GS, TÜV Ergo, UL/cUL, Energy star 5.0
Cabinet	
Color	Black / Black
Finish	Glossy / Texture

**Note:**

This data is subject to change without notice.

Go to www.philips.com/support to download the latest version of leaflet.

2. LCD Monitor Description

191E2

The LCD monitor will contain a scaler board, an adapter board, an inverter board and a key board. The scaler board houses the flat panel control logic, brightness control logic and DDC.

The adapter board will provide AC to DC Inverter voltage to drive the backlight of panel and the scaler board chips each voltage.

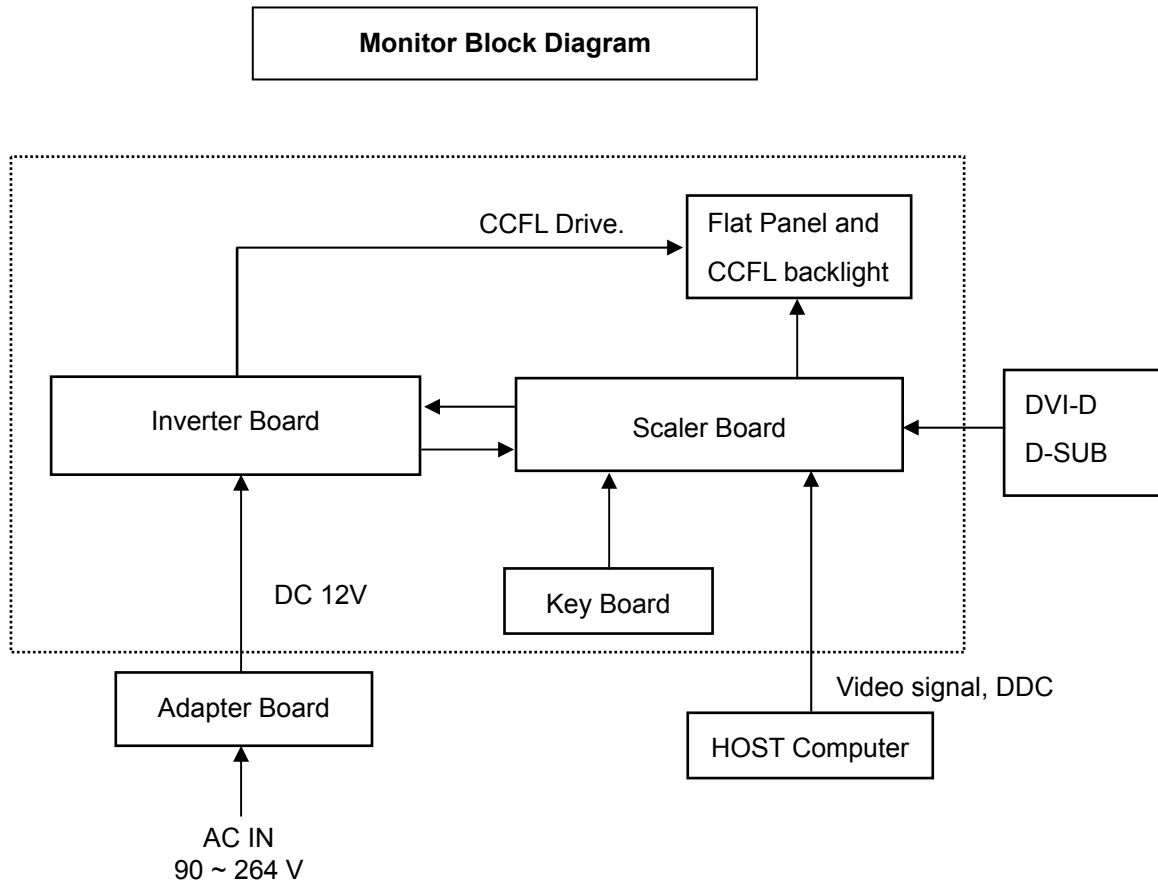

191EL2

The LCD monitor will contain a scaler board, an adapter board, a converter board and a key board. The scaler board houses the flat panel control logic, brightness control logic and DDC.

The adapter board will provide AC to DC Inverter voltage to drive the backlight of panel and the scaler board chips each voltage.

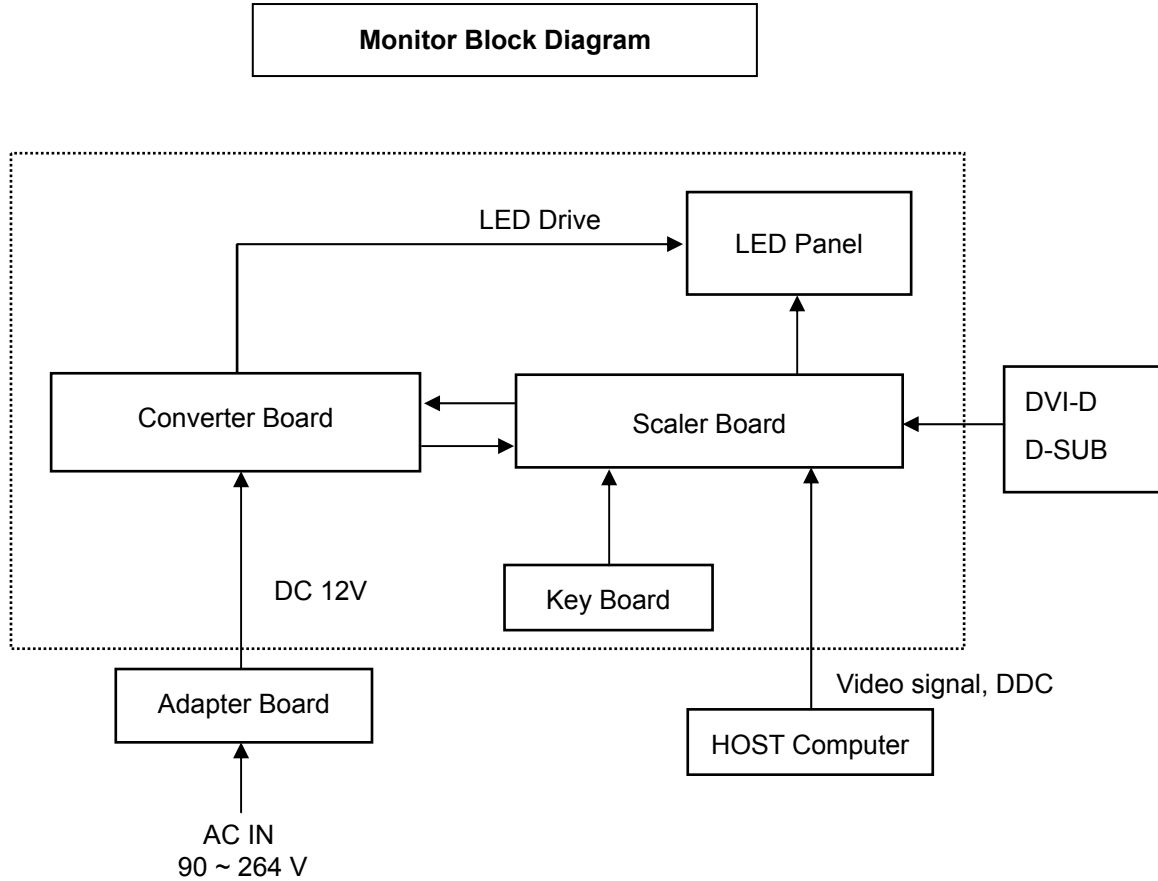

3. Operating Instructions

3.1 General Instructions

Press the power button to turn the monitor on or off.

The other control knobs are located at front panel of the monitor (see figure). By changing these setting, the picture can be adjusted to your personal preference.

- * The power cord should be connected.
- * Press the power button to turn on the monitor. The power indicator will light up.

3.2 Control Buttons

Operating the Monitor

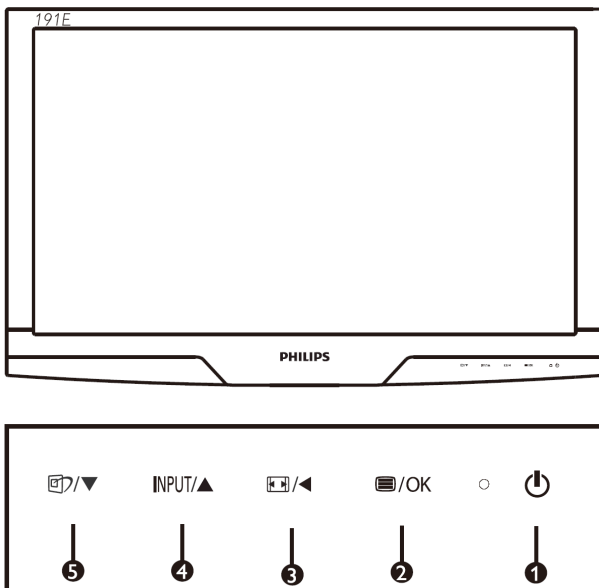

Front view product description

1. To switch monitor's power ON and OFF.
2. : To access the OSD menu
3. : Change to 4:3 display. Return to previous OSD level.
4. **INPUT/▲** : To change the signal input source and adjust the OSD menu.
5. : SmartImage Lite. There are three modes to be selected: Standard, Internet, and Game. To adjust the OSD menu

Connecting to your PC

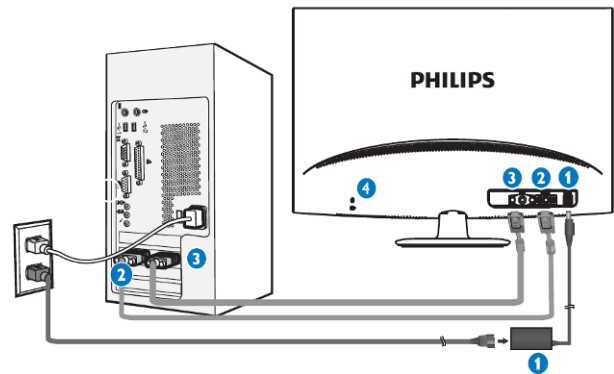

1. DC power input
2. VGA input
3. DVI-D input (available for selected models)
4. Kensington anti-theft lock

Install base stand

1. Place the monitor face down a smooth surface taking care to avoid scratching or damaging the screen.

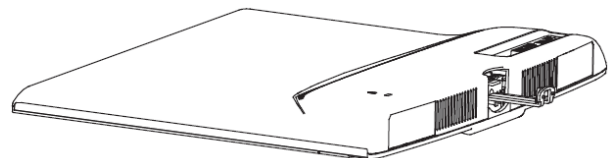

2. Attach the monitor base stand to the base column then fasten base stand.

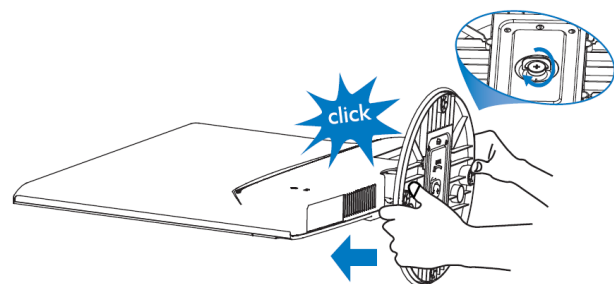

3.3 OSD Menu

On-screen Display (OSD) is feature in all Philips LCD monitors. It allows an end user to adjust screen performance or select functions of the monitors directly through an on-screen display interface is shown as below.

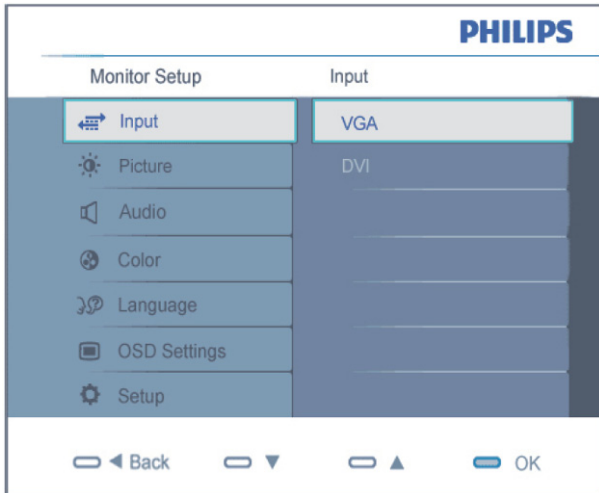

Basic and simple instruction on the control keys

In the OSD shown above users can press ▼▲ buttons at the front bezel of the monitor to move the cursor, OK to confirm the choice or change.

The OSD tree

Below is an overall view of the structure of the On-Screen Display. You can use this as a reference when you want to work your way around the different adjustments later on.

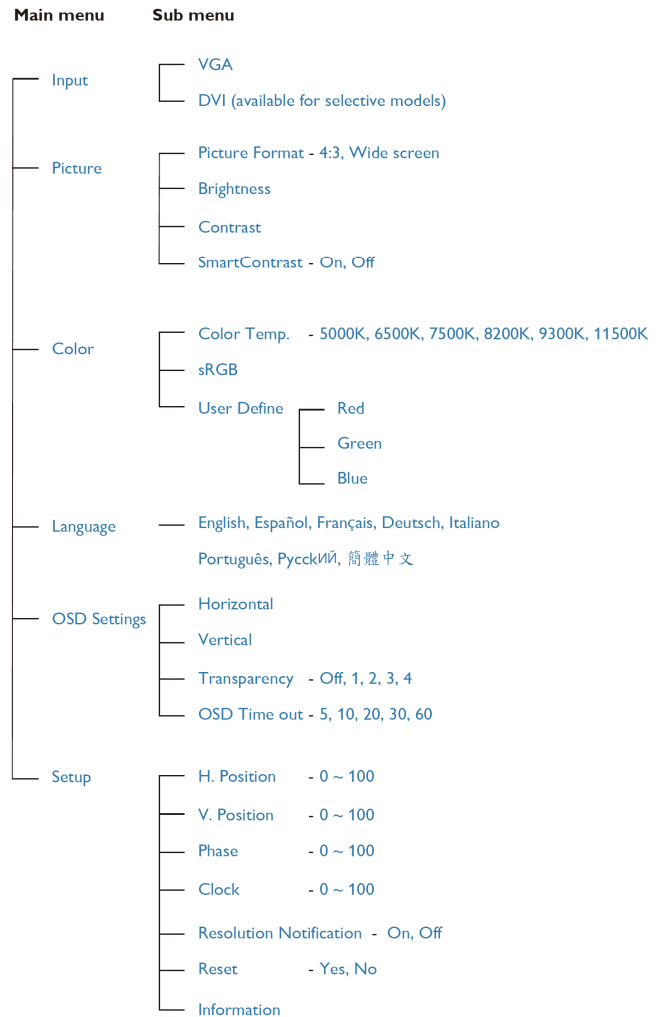

4. Input/ Output Specification

4.1 Input Signal Connector

Analog connectors

Pin No.	Signal Name	Pin No.	Signal Name
1	Red	9	DDC +3V or +5V
2	Green/SOG	10	Logic (GND)
3	Blue	11	Sense (GND)
4	Sense (GND)	12	Bi-directional Data
5	Cable Detect (GND)	13	H/H+V Sync
6	Red GND	14	V-sync
7	Green GND	15	Data Clock
8	Blue GND		

Digital connectors (Option)

Pin No.	Signal Name	Pin No.	Signal Name
1	T.M.D.S. data2-	13	No Connect
2	T.M.D.S. data2+	14	+5V Power
3	T.M.D.S. data2 shield	15	Ground (for +5V) – Cable detect
4	No Connect	16	Hot plug detect
5	No Connect	17	T.M.D.S. data0-
6	DDC clock	18	T.M.D.S. data0+
7	DDC data	19	T.M.D.S. data0 shield
8	No Connect	20	No Connect
9	T.M.D.S. data1-	21	No Connect
10	T.M.D.S. data1+	22	T.M.D.S clock shield
11	T.M.D.S. data1 shield	23	T.M.D.S. clock+
12	No Connect	24	T.M.D.S. clock-

4.2 Resolution & Preset Modes**Maximum Resolution**

1366 x 768 at 60 Hz (analog input)

1366 x 768 at 60 Hz (digital input)

Recommended Resolution

1366 x 768 at 60 Hz (digital input)

H. freq (kHz)	Resolution	V. freq (Hz)
31.47	640 x 480	59.94
37.88	800 x 600	60.32
48.36	1024 x 768	60.00
54.00	1152 x 864	60.00
44.77	1280 x 720	59.86
47.78	1280 x 768	59.87
49.70	1280 x 800	59.81
60.00	1280 x 960	60.00
69.89	1280 x 1024	60.02
47.71	1360 x 768	60.02
47.71	1366 x 468	59.79
55.47	1440 x 900	59.90
55.94	1440 x 900	59.89
75.00	1600 x 1200	60.00
64.67	1680 x 1050	59.88
65.29	1680 x 1050	59.95
66.59	1920 x 1080	59.93
74.04	1920 x 1200	59.95

4.3 Pixel Defect Policy

Philips strives to deliver the highest quality products. We use some of the industry's most advanced manufacturing process and practice stringent quality control. However, pixel or sub pixel defects on the TFT LCD panels used in flat panel monitors are sometimes unavoidable. No manufacturer can guarantee that panels will be free from pixel defects, but Philips guarantees that any monitor with an unacceptable number of defects will be repaired or replaced under warranty. This notice explains the different types of pixel defects and defines acceptable defect levels for each type. In order to qualify for repair or replacement under warranty, the number of pixel defects on a TFT LCD panel must exceed these acceptable levels. For example, no more than 0.0004% of the sub pixels on an 18.5" XGA monitor may be defective. Furthermore, Philips sets even higher quality standard for certain types or combinations of pixel defects that are more noticeable than others. This policy is valid worldwide.

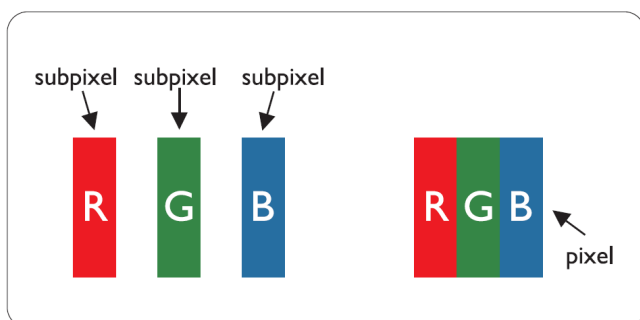

Pixels and Sub pixels

A pixel, or picture element, is composed of three sub pixels in the primary colors of red, green and blue. Many pixels together form an image. When all sub pixels of pixel are lit, the three colored sub pixels together appear as a single white pixel. When all are dark, the three colored sub pixels together appear as a signal black pixel. Other combinations of lit and dark sub appear as single pixels of other colors.

Types of Pixel Defects

Pixel and sub pixel defects appear on the screen in different ways. There are two categories of pixel

defects and several types of sub pixel defects within each category.

Bright Dot Defects Bright dot defects appear as pixels or sub pixels that are always lit or 'on'. That is, a Bright dot is a sub-pixel that stands out on the screen when the monitor displays a dark pattern. There are three types of bright dot defects:

One lit red, green or blue sub pixel

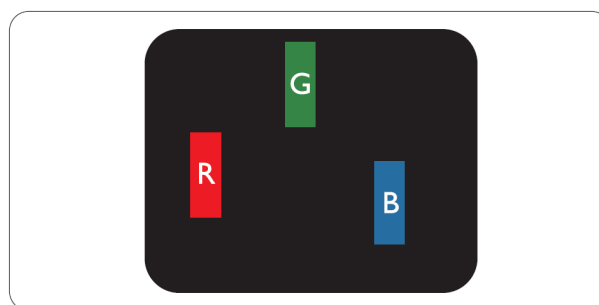

Two adjacent lit sub pixels:

- Red + Blue = Purple
- Red + Green = Yellow
- Green + Blue = Cyan (Light Blue)

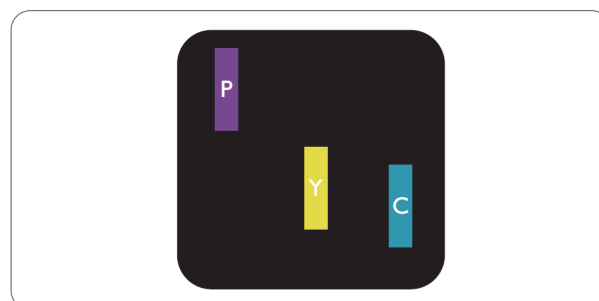

Three adjacent lit sub pixels (one white pixel)



Note:

A red or blue bright dot must be more than 50 percent brighter than neighboring dots while a green bright dot is 30 percent brighter than neighboring dots.

14 Meridian 2

Black Dot Defects Black dot defects appear as pixels or sub pixels that are always dark or 'off'. That is, a dark dot is a sub-pixel that stands out on the screen when the monitor displays a light pattern. There are two types of black dot defects:

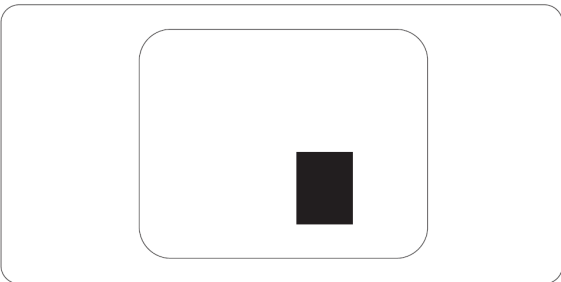
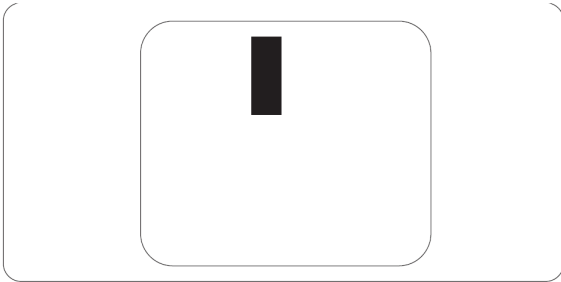

Proximity of Pixel Defects

Because pixel and sub pixels defects of the same type that are near to one another may be more noticeable, Philips also specifies tolerances for the proximity of pixel defects.

Pixel Defect Tolerances

In order to qualify for repair or replacement due to pixel defects during the warranty period, a TFT LCD panel in a Philips flat panel monitor must have pixel or sub pixel defects exceeding the tolerances listed in the following tables.

Bright Dot Defects	Acceptable level
MODEL	191E2/191EL2
1 lit subpixel	3
2 adjacent lit subpixels	1
3 adjacent lit subpixels (one white pixel)	0
Distance between two bright dot defects*	>15mm
Total bright dot defects of all types	3

Black Dot Defects	Acceptable level
MODEL	191E2/191EL2
1 dark subpixel	5 or fewer
2 adjacent dark subpixels	2 or fewer
3 adjacent dark subpixels	0
Distance between two black dot defects*	>15mm
Total black dot defects of all types	5 or fewer

Total Dot Defects	Acceptable level
MODEL	191E2/191EL2
Total bright or black dot defects of all types	5 or fewer

 **Note:** 1 or 2 adjacent sub pixel defects = 1 dot defect

4.4 Failure Mode Of Panel

Quick reference for failure mode of LCD panel

this page presents problems that could be made by LCD panel. It is not necessary to repair circuit board. Simply follow the mechanical instruction on this manual to eliminate failure by replace LCD panel.

Failure description

Phenomenon

Vertical block defect

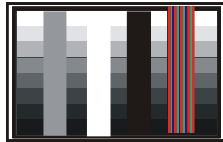

Polarizer has bubbles

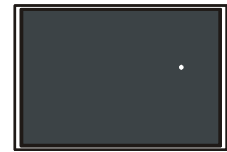

Vertical dim lines

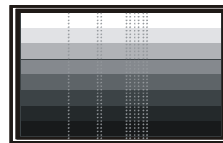

Polarizer has bubbles



Vertical lines defect
(Always bright or dark)

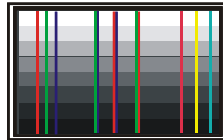

Foreign material inside polarizer. It shows liner or dot shape.



Horizontal block defect



Concentric circle formed



Horizontal dim lines

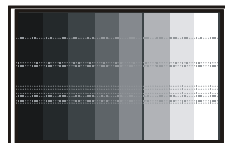

Bottom back light of LCD is brighter than normal



Horizontal lines defect
(Always bright or dark)

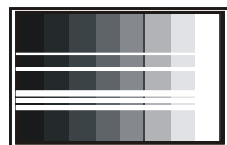

Back light un-uniformity



Has bright or dark pixel



Backlight has foreign material. Black or white color, liner or circular type



5. Block Diagram

5.1 Scaler Board

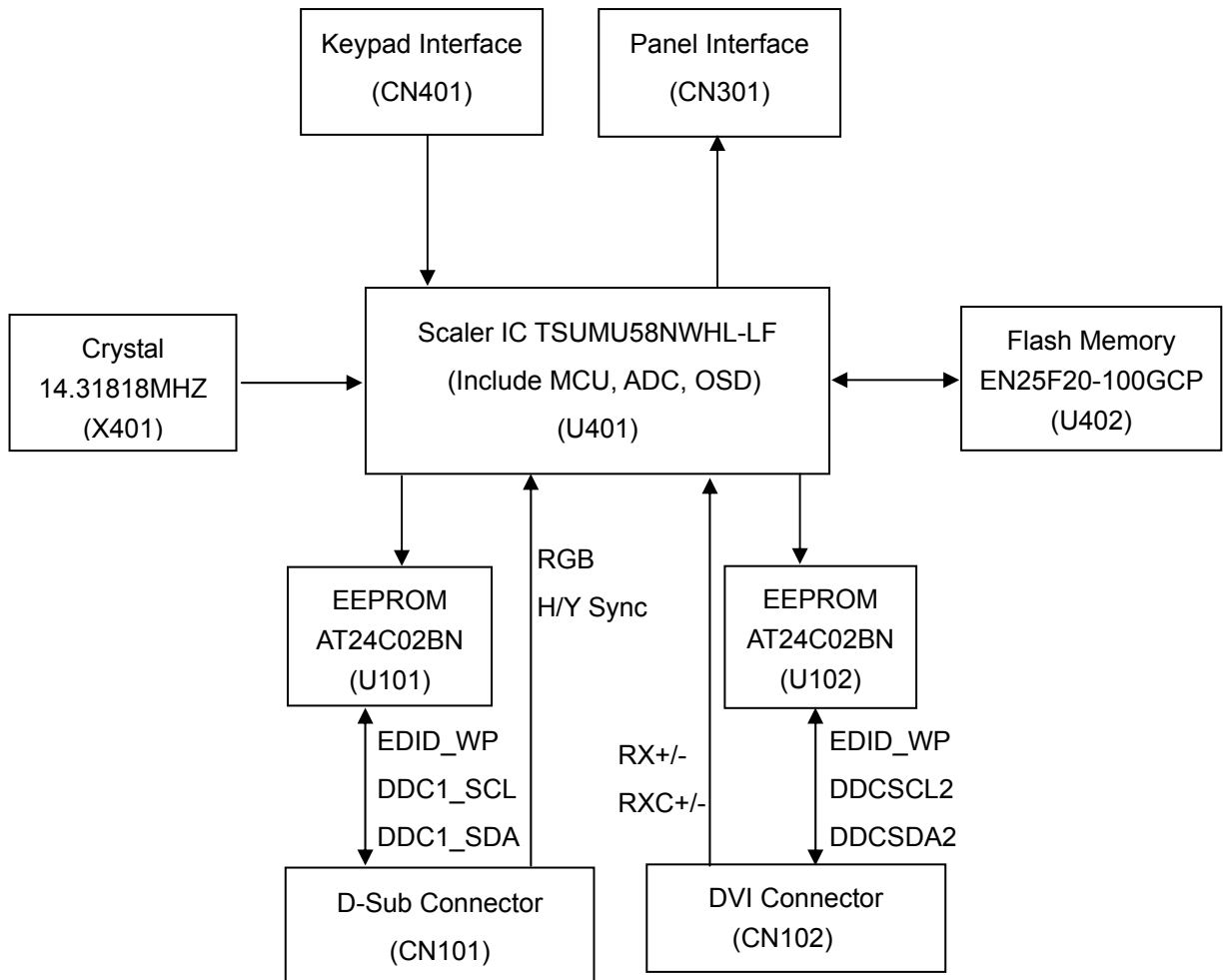

715G4411M0100004I

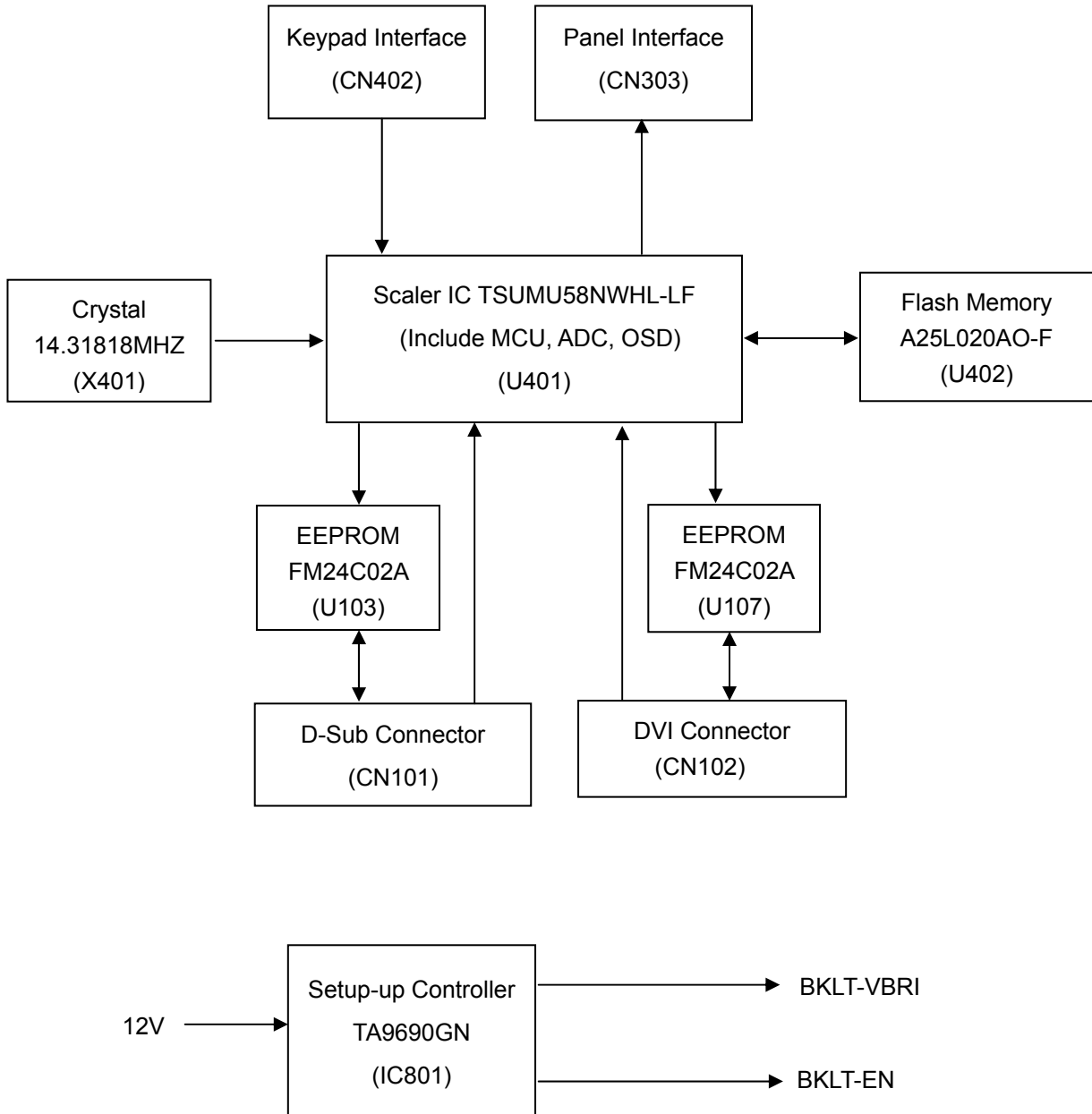

5.2 Adapter/Inverter/Converter Board

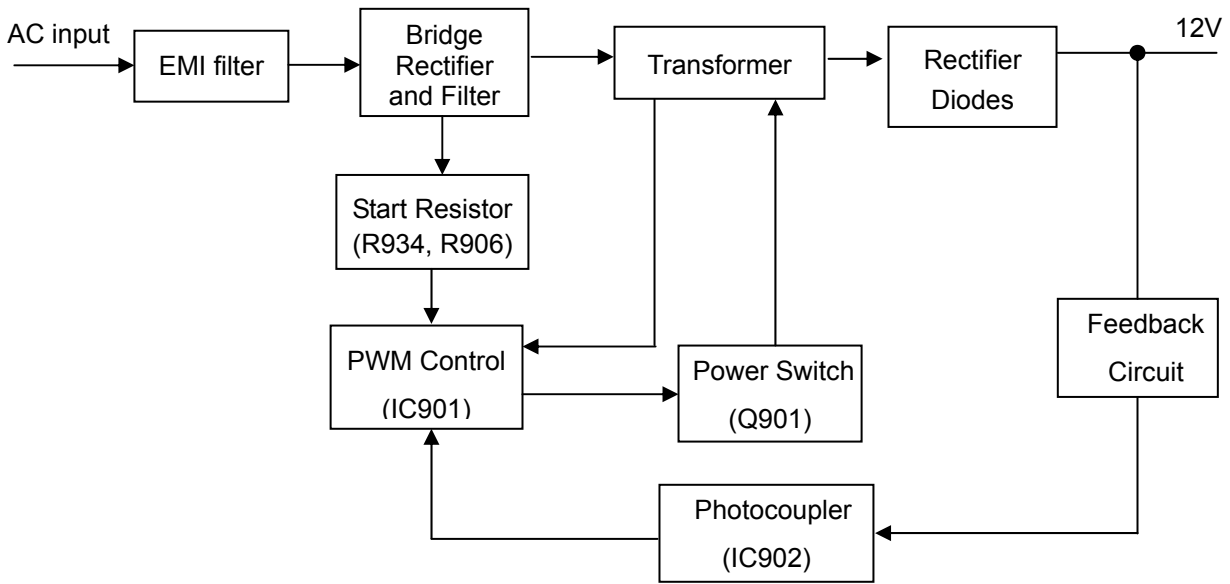

Inverter Board for 191E2

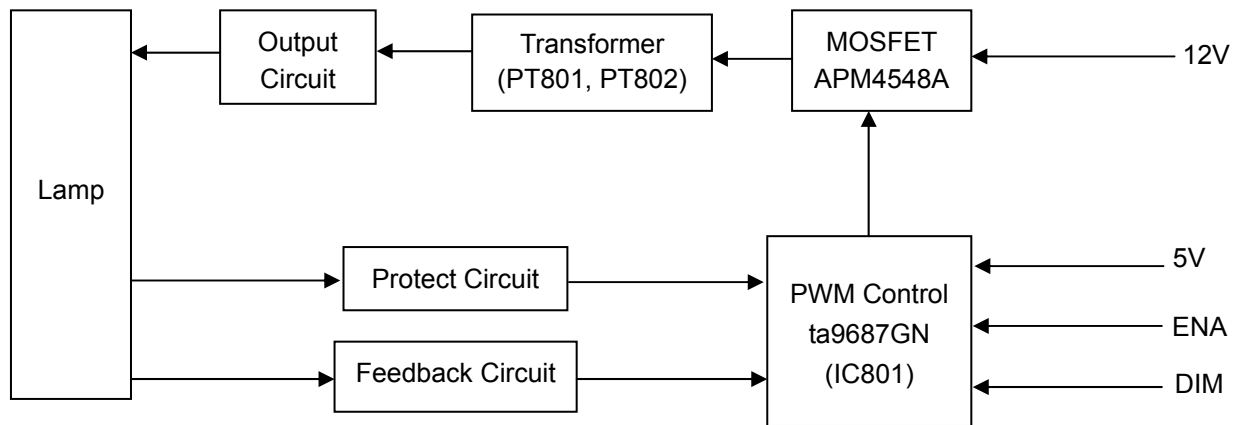

Converter Board for 191EL2

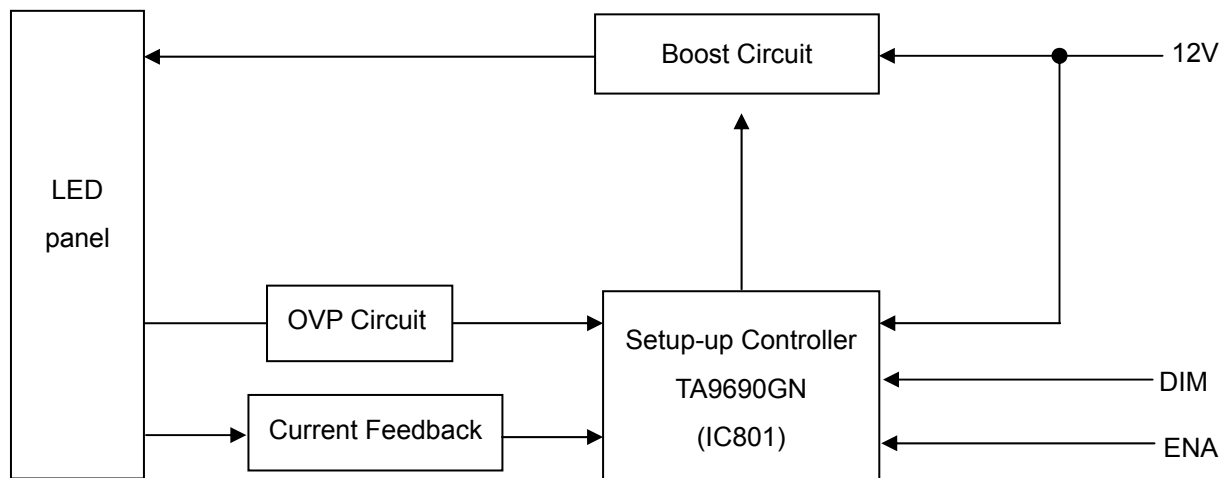

6. Schematic

6.1 Scaler Board (715G3598M0J00004W)

Remark: Parts position can be searched by using FIND function in PDF.

Input

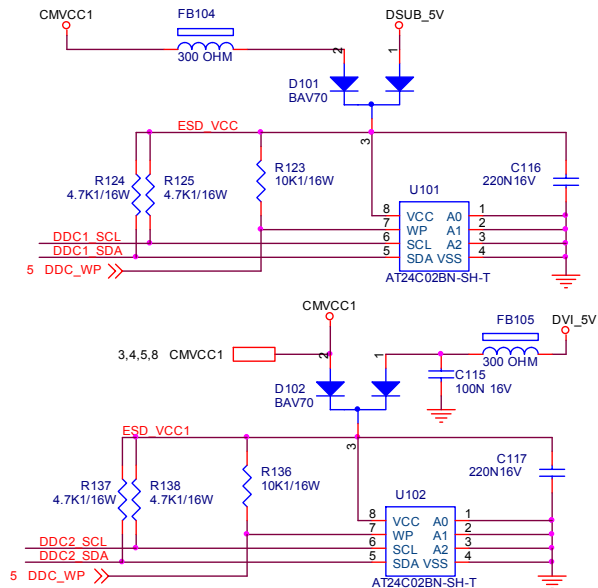
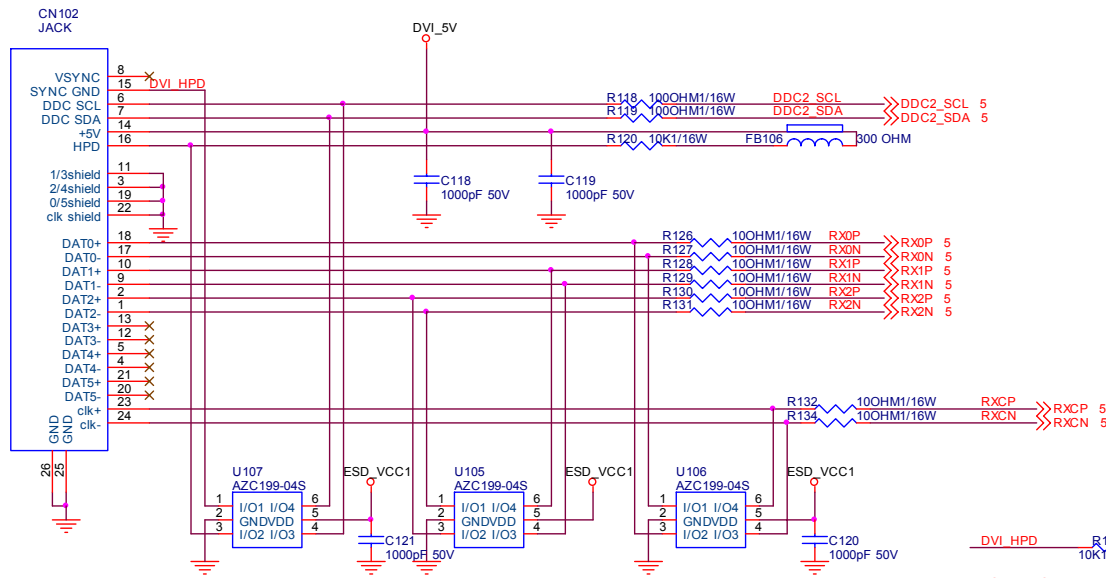
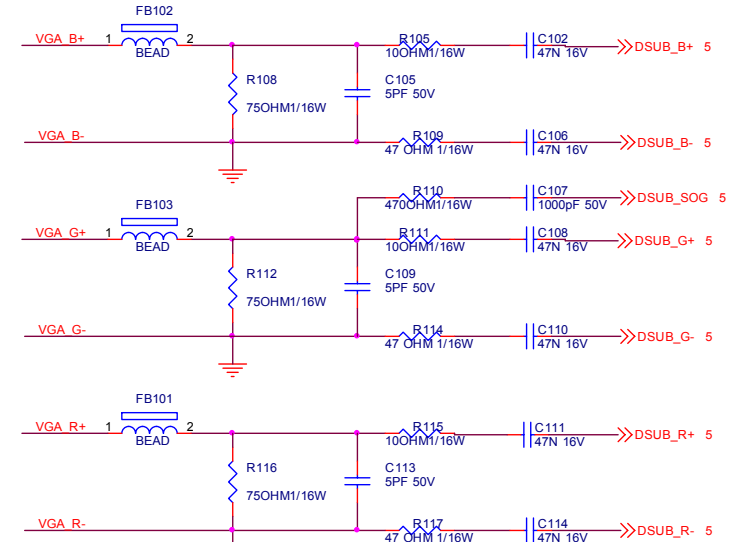
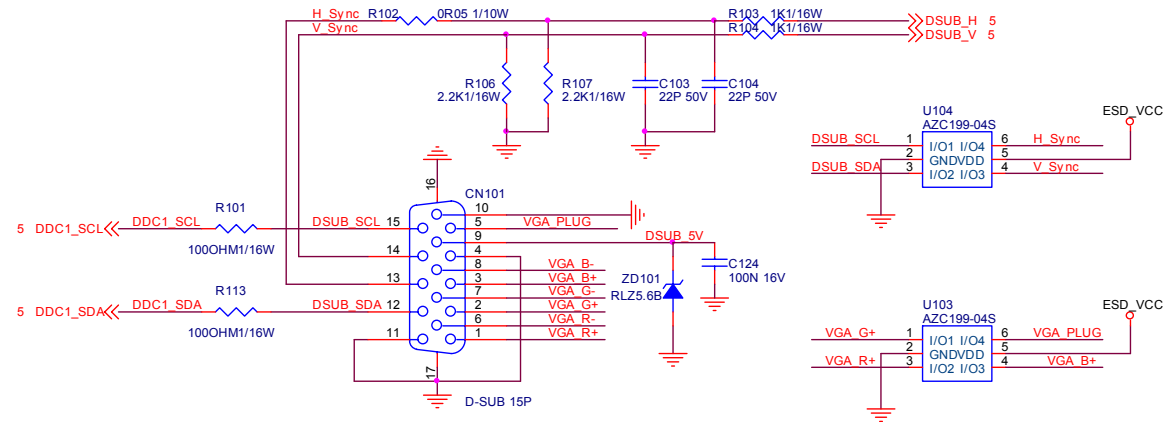

Remark: Parts position can be searched by using FIND function in PDF.

Output

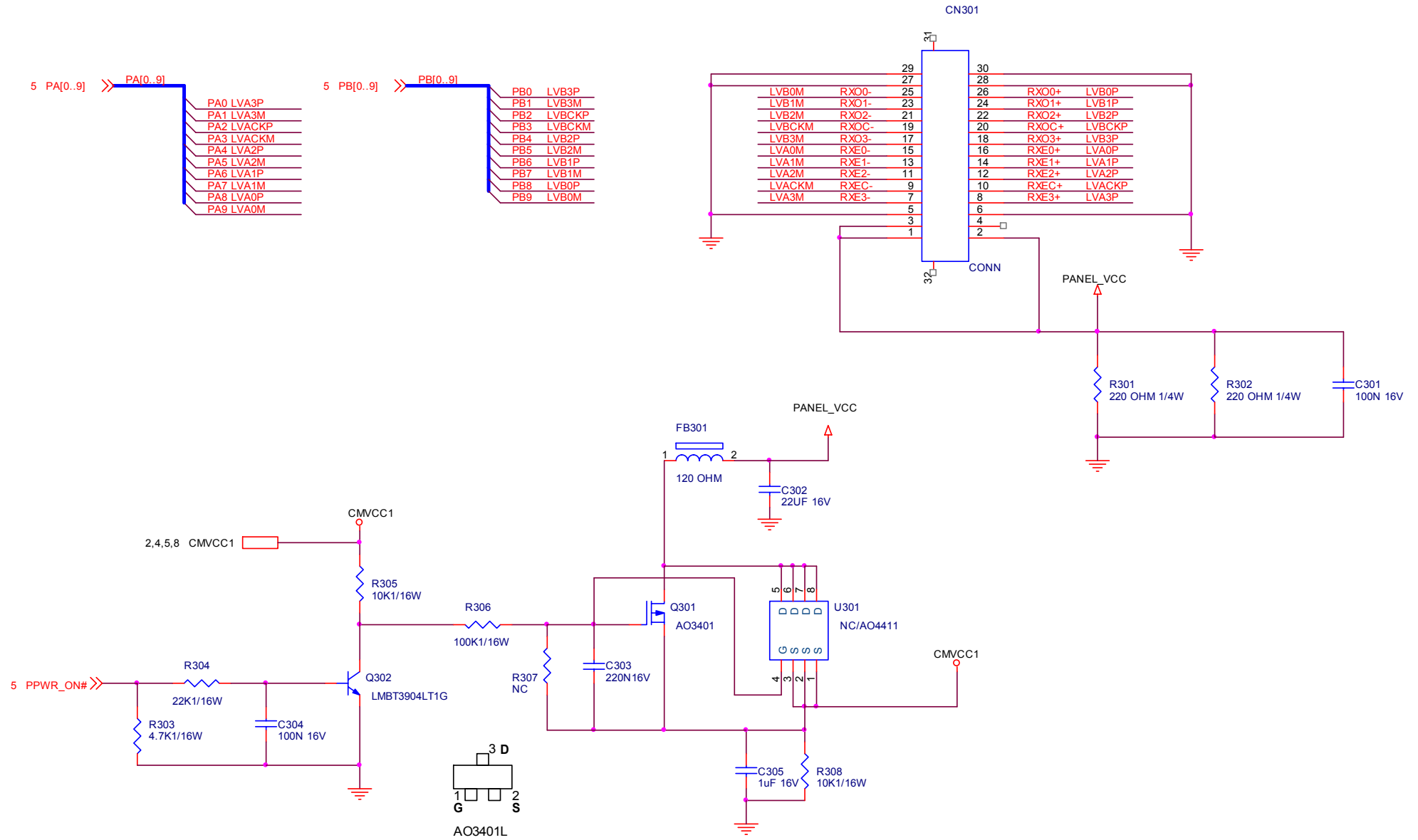

Remark: Parts position can be searched by using FIND function in PDF.

Power

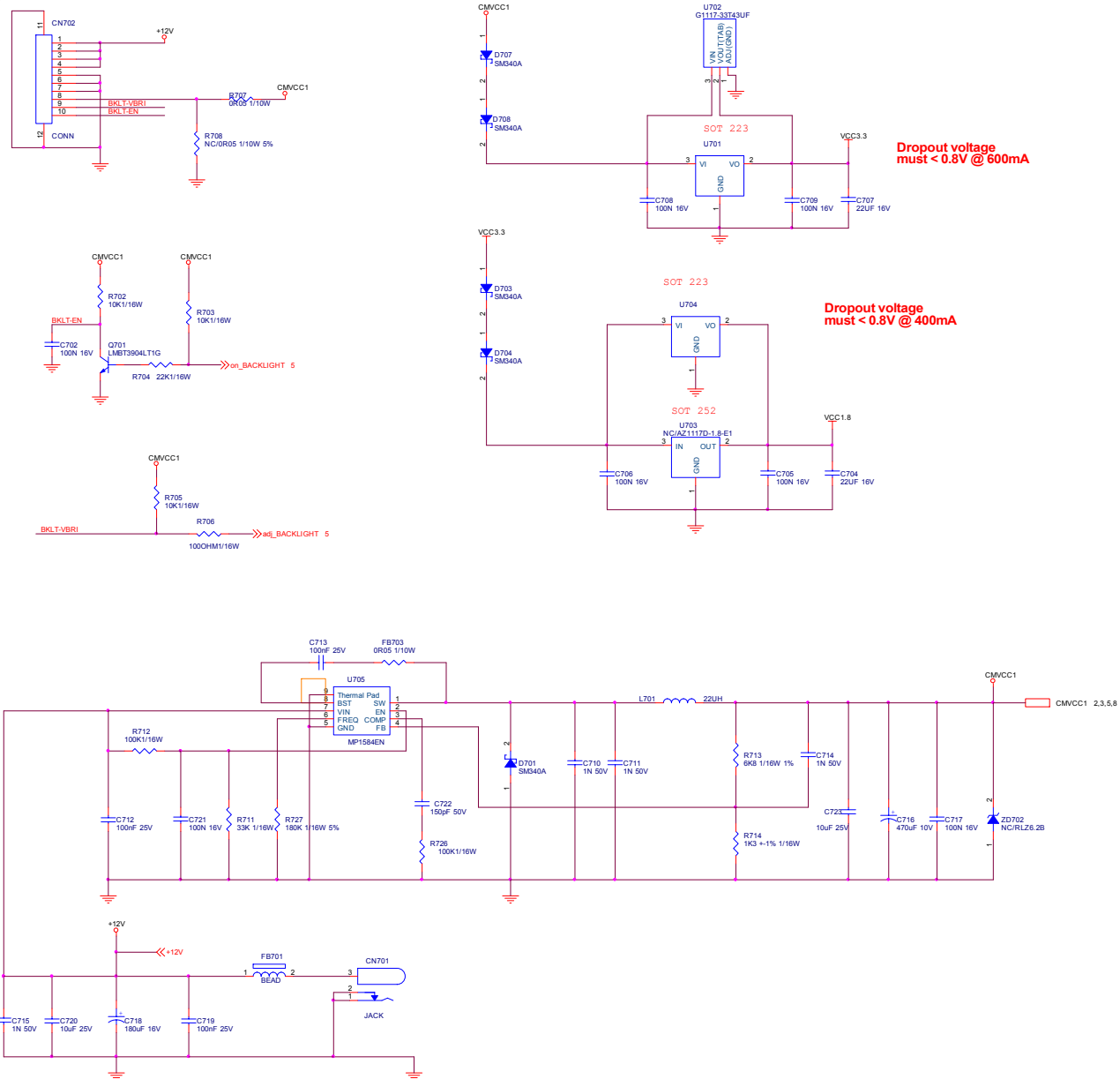

Remark: Parts position can be searched by using FIND function in PDF.

Scaler

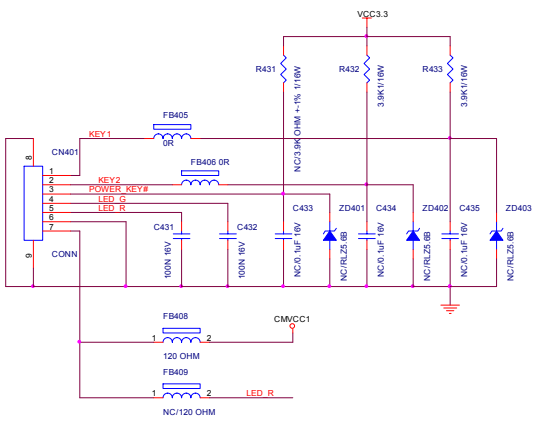
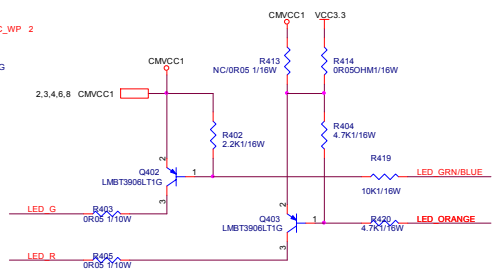
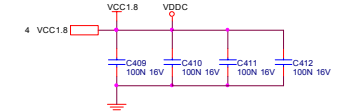
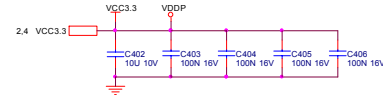
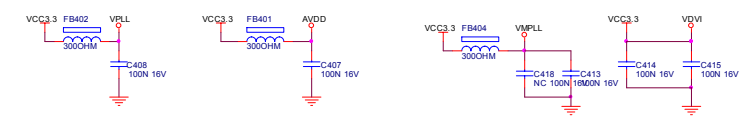
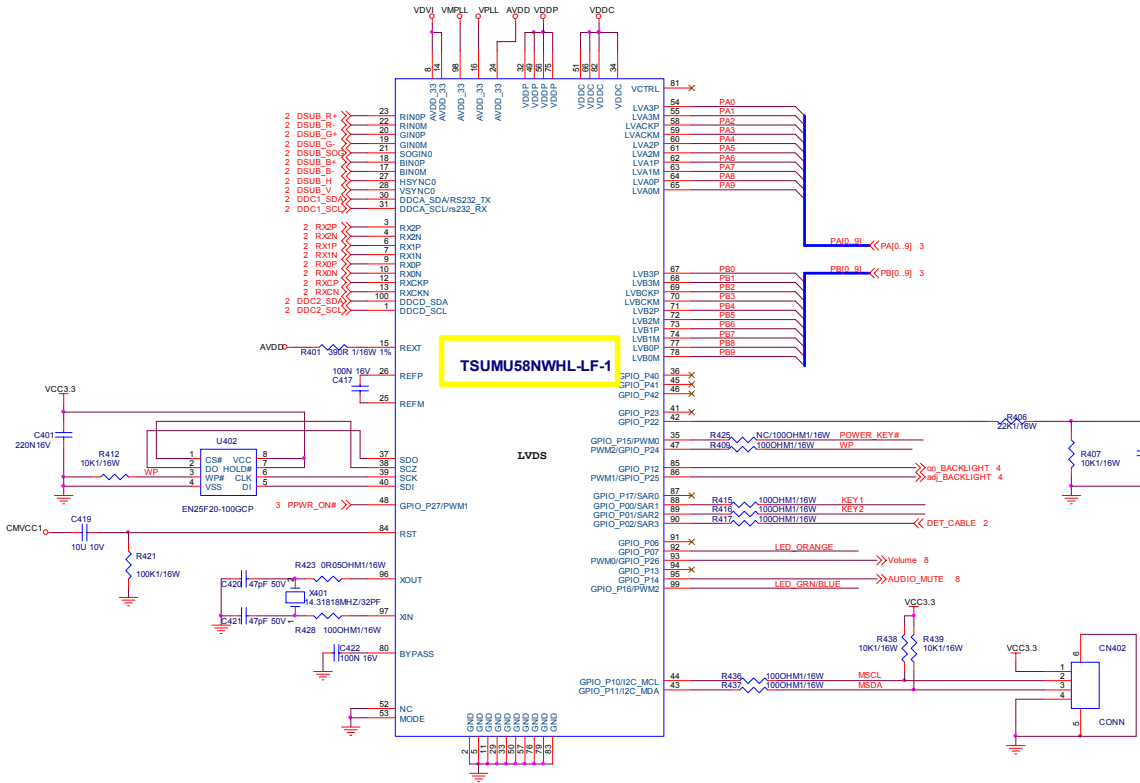

	U402
SST	For user data, WB, EDID, HDCP are saved in Flash.
SST	U402
010A	Befor AOC ID2007 OSD
020A	For ID2008 ID2009
Eon	U402
020	For All model

X'TAL			
Normal Function : $CL = C_s + ((C_g * C_d) / (C_g + C_d))$			
P.S : Assume $C_s = 4 \text{ pF}$			
X401	CL of SPEC	Cs and Cd (C420, C421)	
萬 (93G 22-53B-H)	18 pF	27 pF	
瑞紅 (93G 22-53-J)	32 pF	47 pF	

Max condition for LED:
 1. Vcc = 3.3 V
 2. Current = 12 mA
 FW need to be modified.

715G4411M01000004I

Remark: Parts position can be searched by using FIND function in PDF.

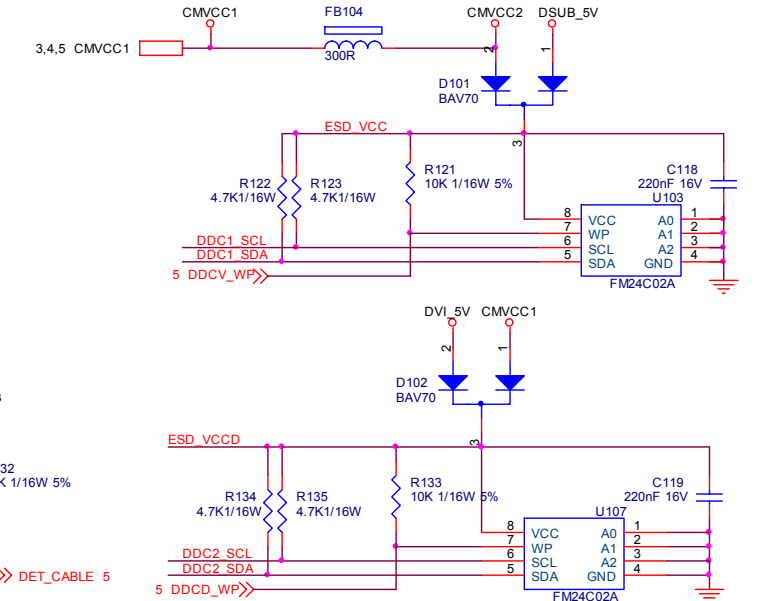
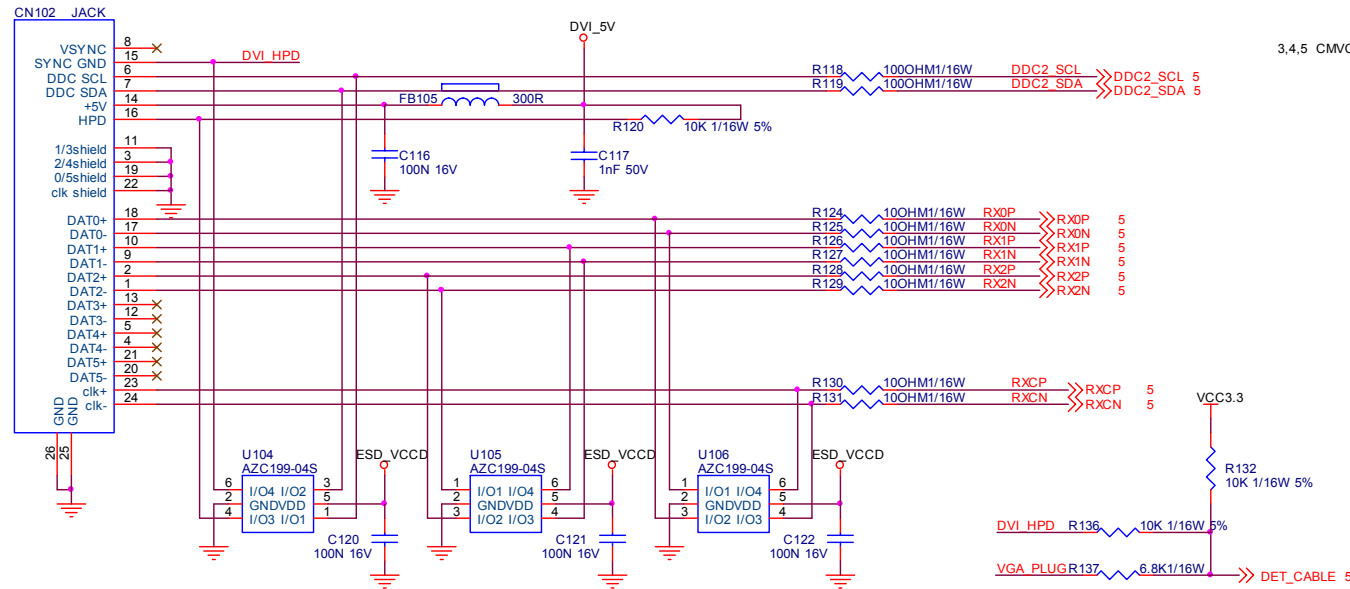
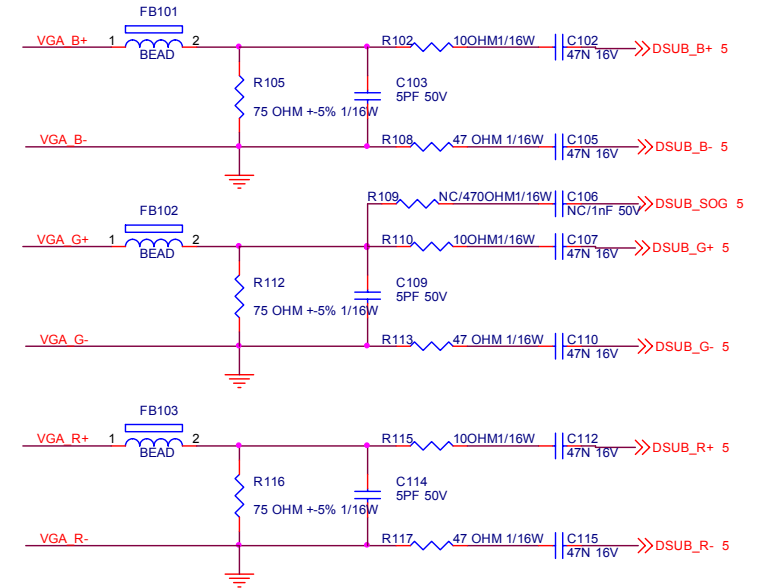
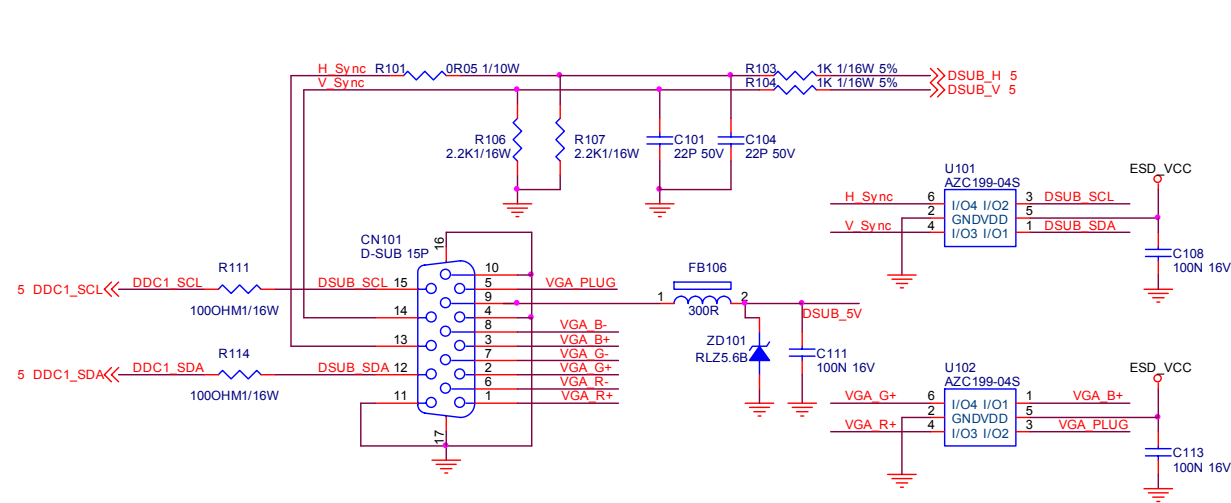

Remark: Parts position can be searched by using FIND function in PDF.

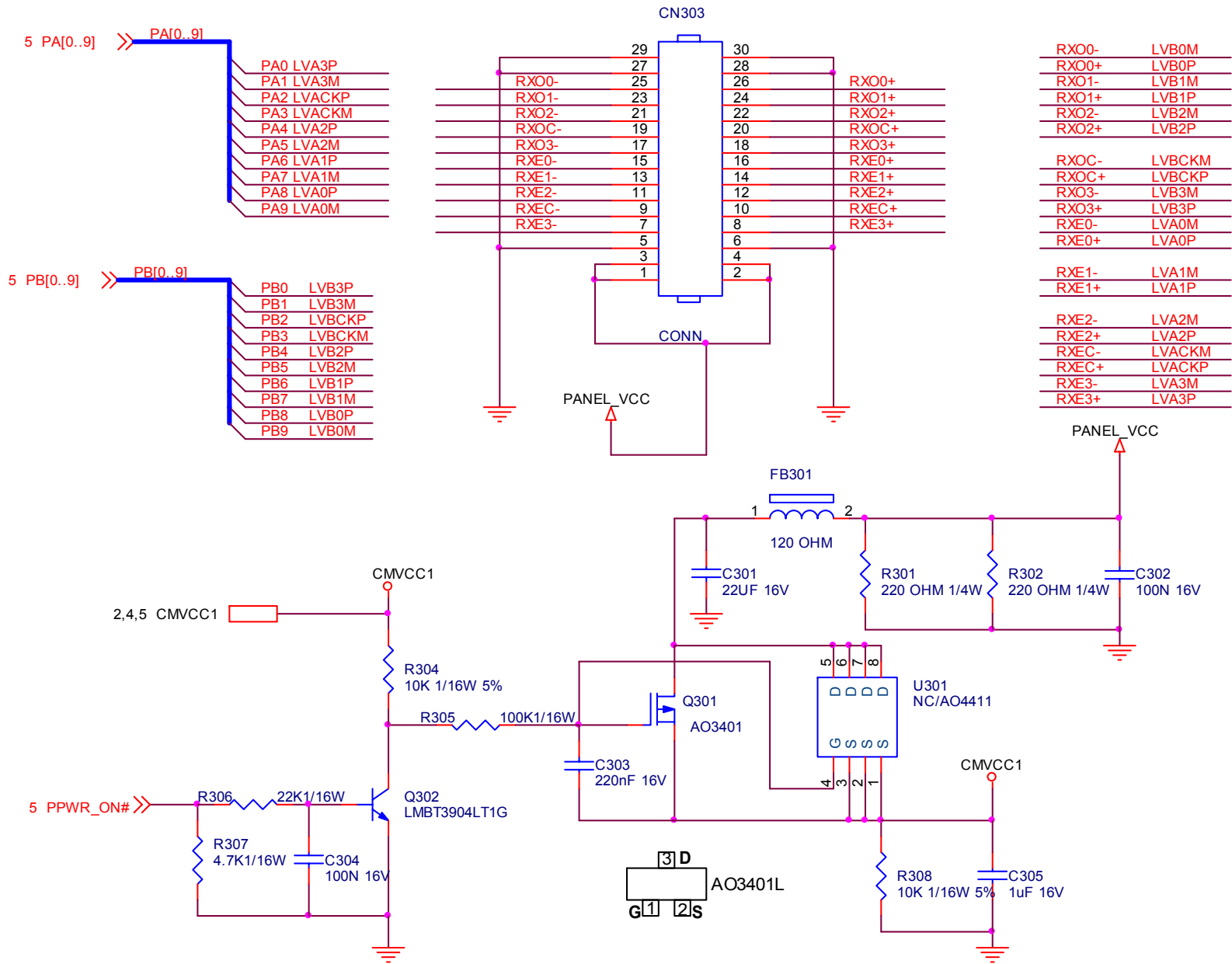

Remark: Parts position can be searched by using FIND function in PDF.

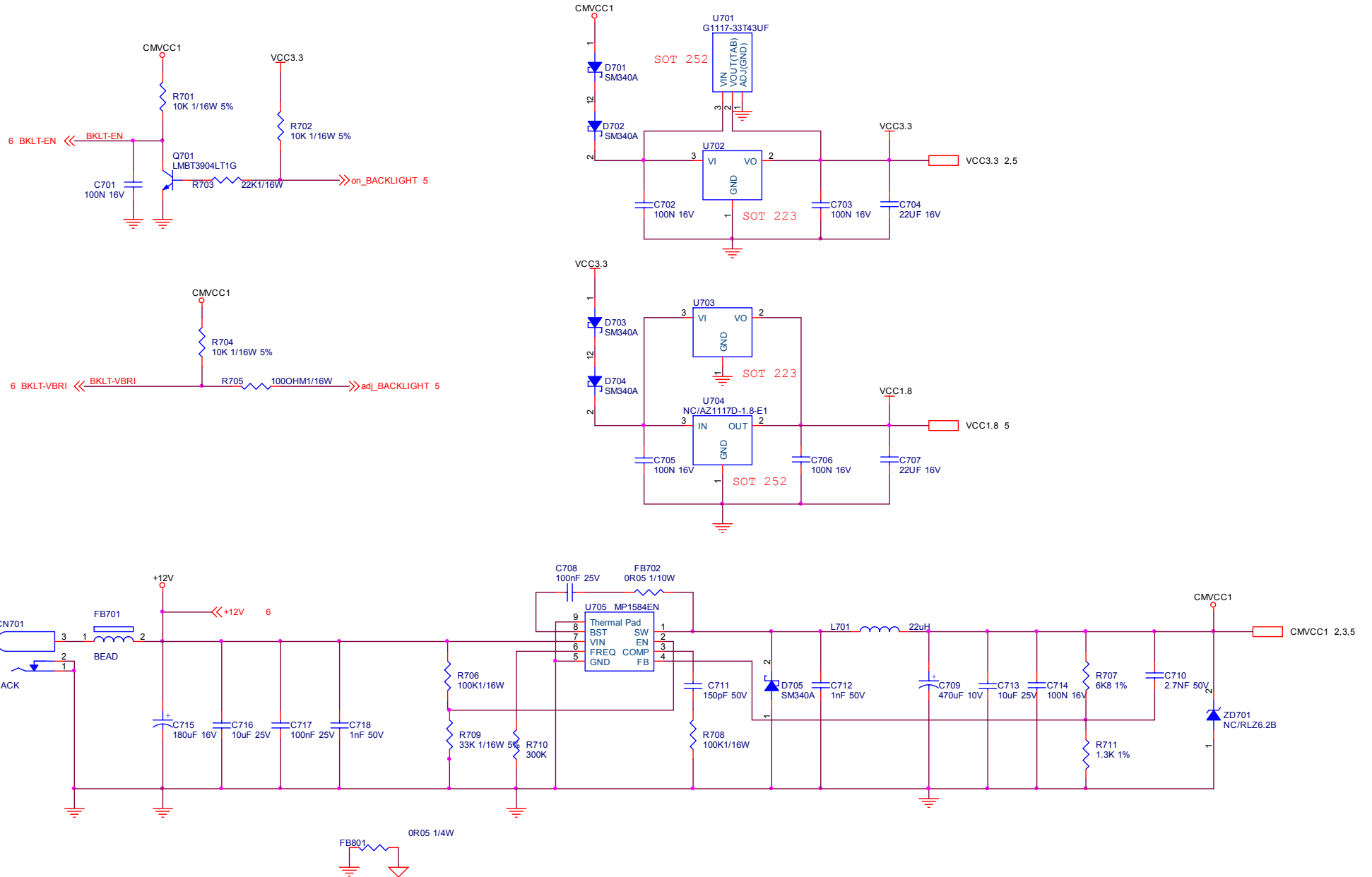

Remark: Parts position can be searched by using FIND function in PDF.

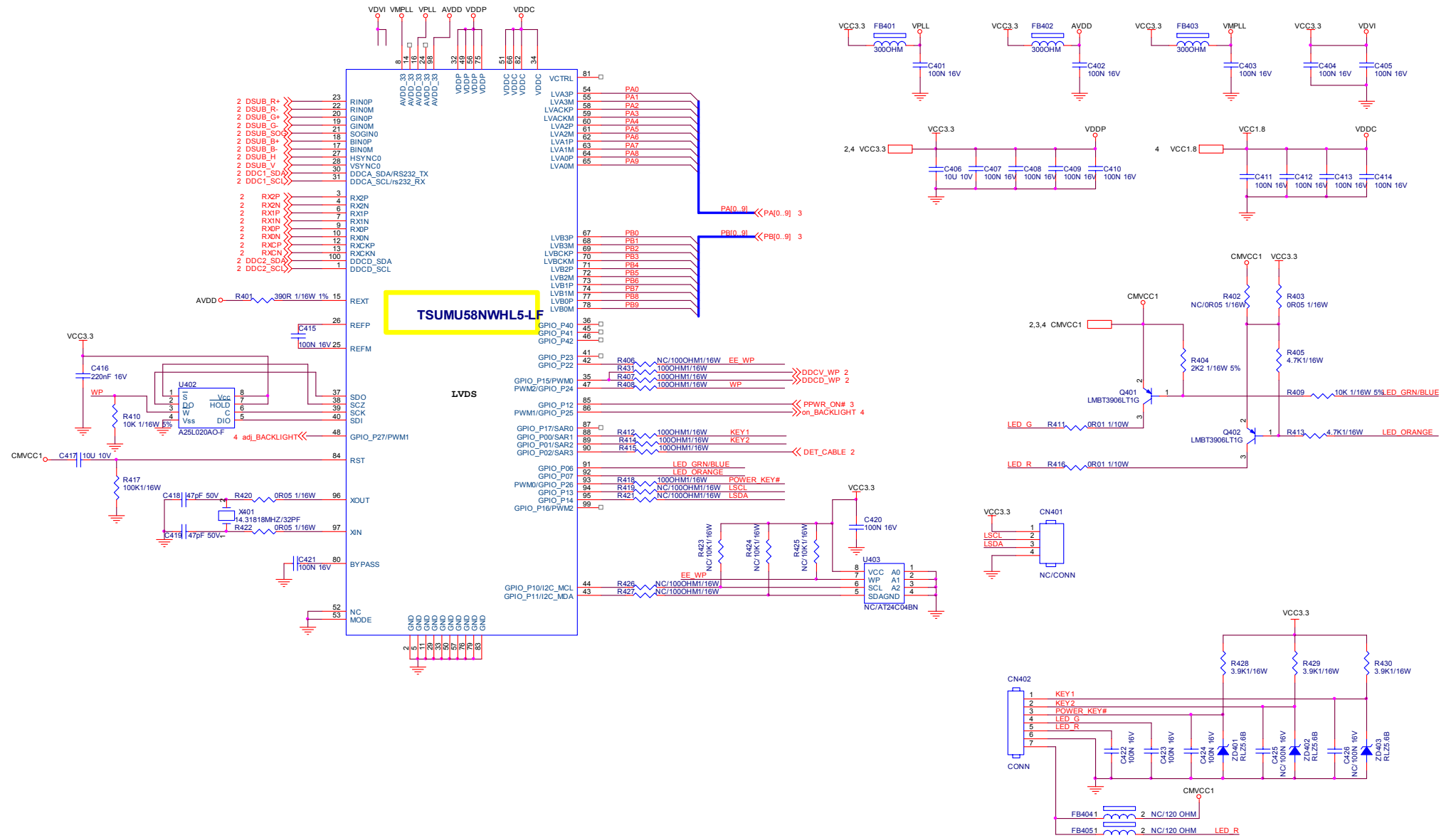

Remark: Parts position can be searched by using FIND function in PDF.

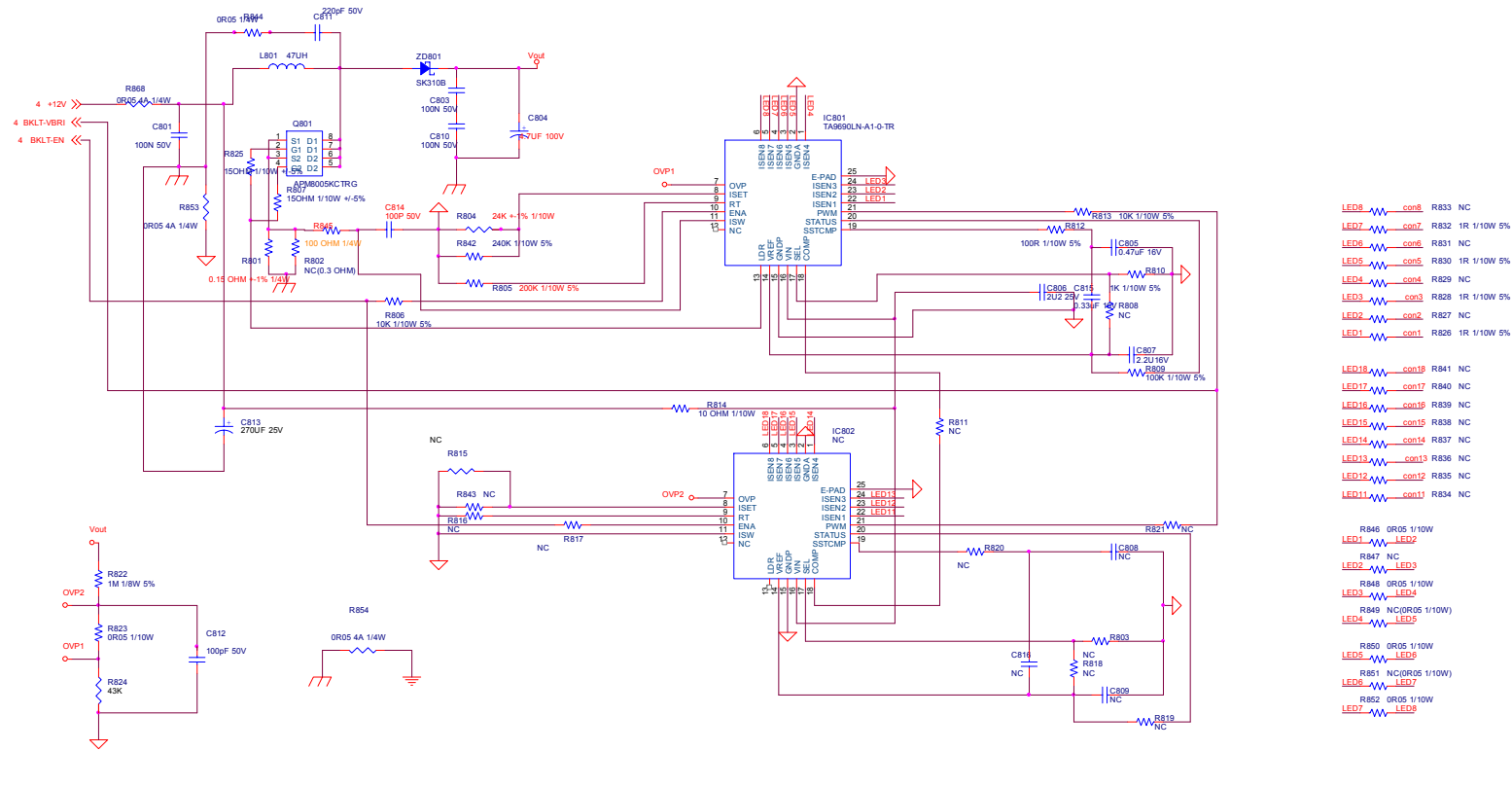

	A00 M183XW01 V6	(TPV)T9M15B1-XM03	CPT CLAA185MA04	SEC L2H185A04	A00 M215W01 V6	LOG (MG)15W4-TLAI	CMO M215B1-LAI	CPT CLAA215FA04 V2
R826	1R	1R	1R	1R	1R	NC	1R	1R
R827	1R	1R	1R	NC	1R	NC	1R	1R
R828	1R	1R	1R	1R	1R	NC	1R	1R
R829	1R	1R	1R	NC	1R	1R	1R	1R
R830	1R	1R	1R	1R	1R	1R	1R	1R
R831	1R	1R	1R	NC	1R	NC	1R	1R
R832	NC	1R	1R	1R	1R	NC	NC	1R
R833	NC	1R	1R	NC	1R	NC	NC	1R
R834	NC	NC	NC	NC	1R	NC	NC	1R
R835	NC	NC	NC	NC	1R	NC	NC	1R
R836	NC	NC	NC	NC	1R	NC	NC	1R
R837	NC	NC	NC	NC	1R	NC	NC	1R
R838	NC	NC	NC	NC	1R	NC	NC	1R
R839	NC	NC	NC	NC	1R	NC	NC	1R
R840	NC	NC	NC	NC	1R	NC	NC	1R
R841	NC	NC	NC	NC	1R	NC	NC	1R
R846	NC	NC	NC	0R	NC	0R	NC	NC
R847	NC	NC	NC	NC	NC	0R	NC	NC
R848	NC	NC	NC	0R	NC	0R	NC	NC
R849	NC	NC	NC	NC	NC	0R	NC	NC
R850	NC	NC	NC	0R	NC	0R	NC	NC
R851	NC	NC	NC	NC	NC	0R	NC	NC
R852	NC	NC	NC	0R	NC	0R	NC	NC

	A00 M183XW01 V6	(TPV)T9M15B1-XM03	CPT CLAA185MA04	SEC L2H185A04	A00 M215W01 V6	LOG (MG)15W4-TLAI	CMO M215B1-LAI	CPT CLAA215FA04 V2
R804	30K	24K	30K	24K	30K	56K	15K	30K
R824	NC	NC	NC	240K	NC	196K	NC	NC
R824	34K	39K	39K	39K	47K	27K	36K	52.3K
R823	0R	0R	0R	0R	0R	0R	0R	0R
R808	1K	NC	NC	NC	NC	NC	1K	NC
R810	NC	1K	1K	1K	1K	1K	NC	1K
IC802	NC	NC	NC	NC	9690	NC	NC	9690
R811	NC	NC	NC	NC	0R	NC	NC	0R
R821	NC	NC	NC	NC	10K	NC	NC	10K
R817	NC	NC	NC	NC	10K	NC	NC	10K
R820	NC	NC	NC	NC	100R	NC	NC	100R
C808	NC	NC	NC	NC	0.47u	NC	NC	0.47u
C816	NC	NC	NC	NC	0.33u	NC	NC	0.33u
R803	NC	NC	NC	NC	1K	NC	NC	1K
C809	NC	NC	NC	NC	2.2u	NC	NC	2.2u
R819	NC	NC	NC	NC	100K	NC	NC	100K
R816	NC	NC	NC	NC	XX K	NC	NC	XX K
R815	NC	NC	NC	NC	XX K	NC	NC	XX K
R843	NC	NC	NC	NC	XX K	NC	NC	XX K

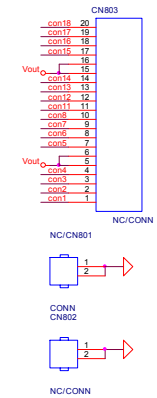

6.3 Inverter Board

191E2 (715G3599P01000001S)

Remark: Parts position can be searched by using FIND function in PDF.

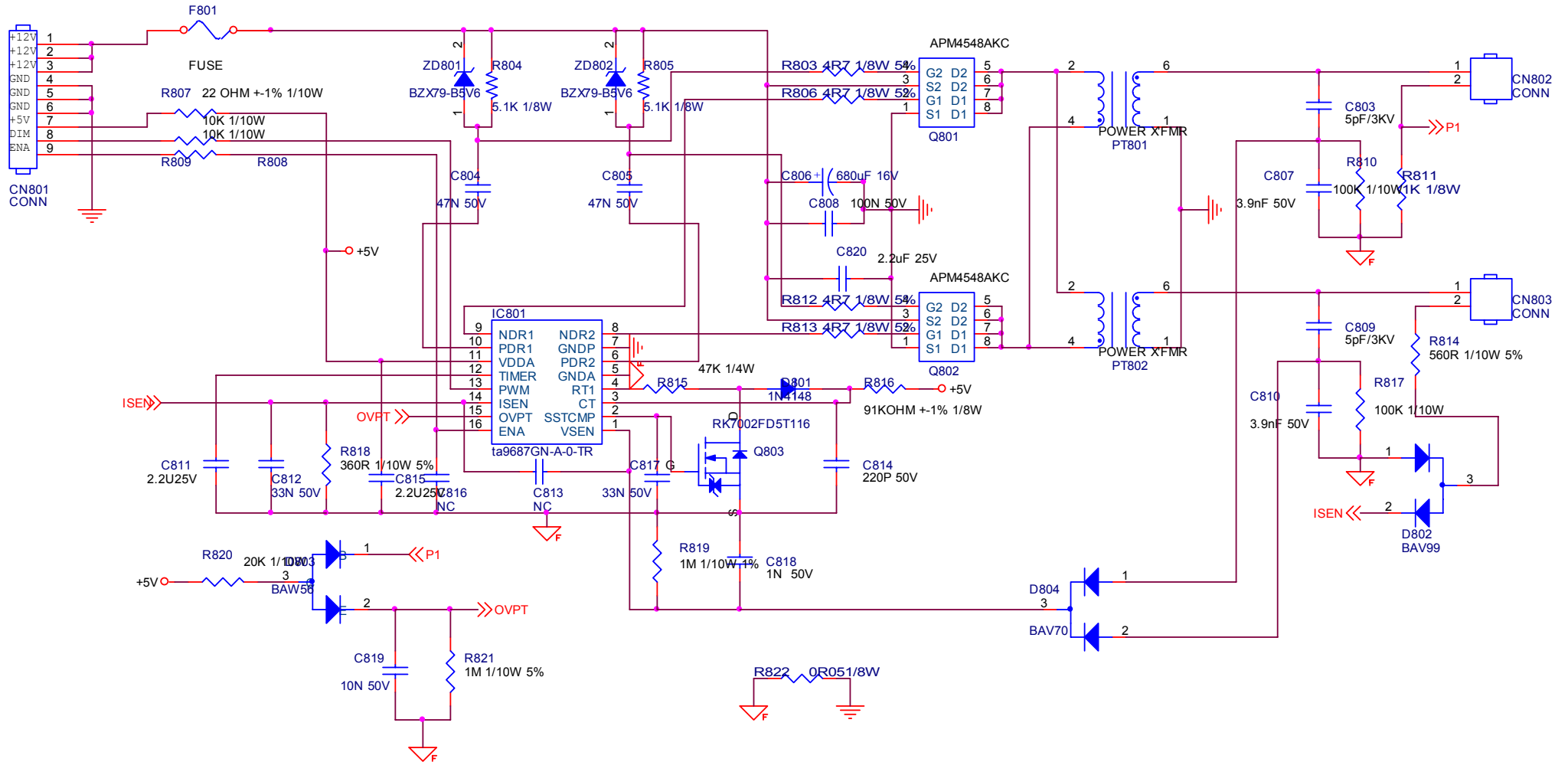

6.4 Converter Board

191EL2 (715G3823P04000004W)

Remark: Parts position can be searched by using FIND function in PDF.

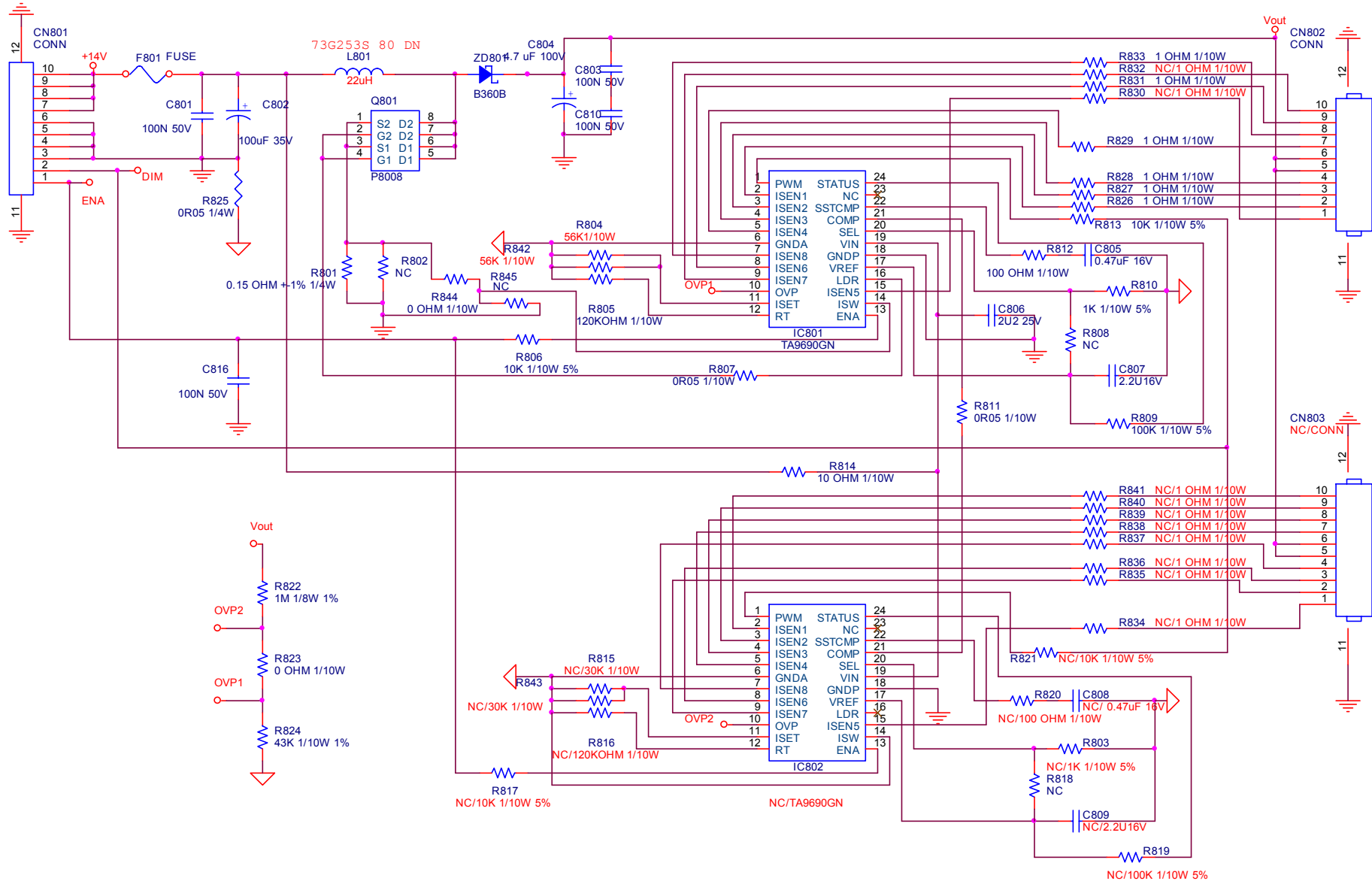

715G4137P0100004S

Remark: Parts position can be searched by using FIND function in PDF.

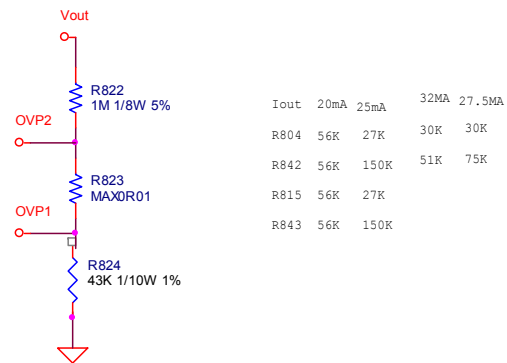
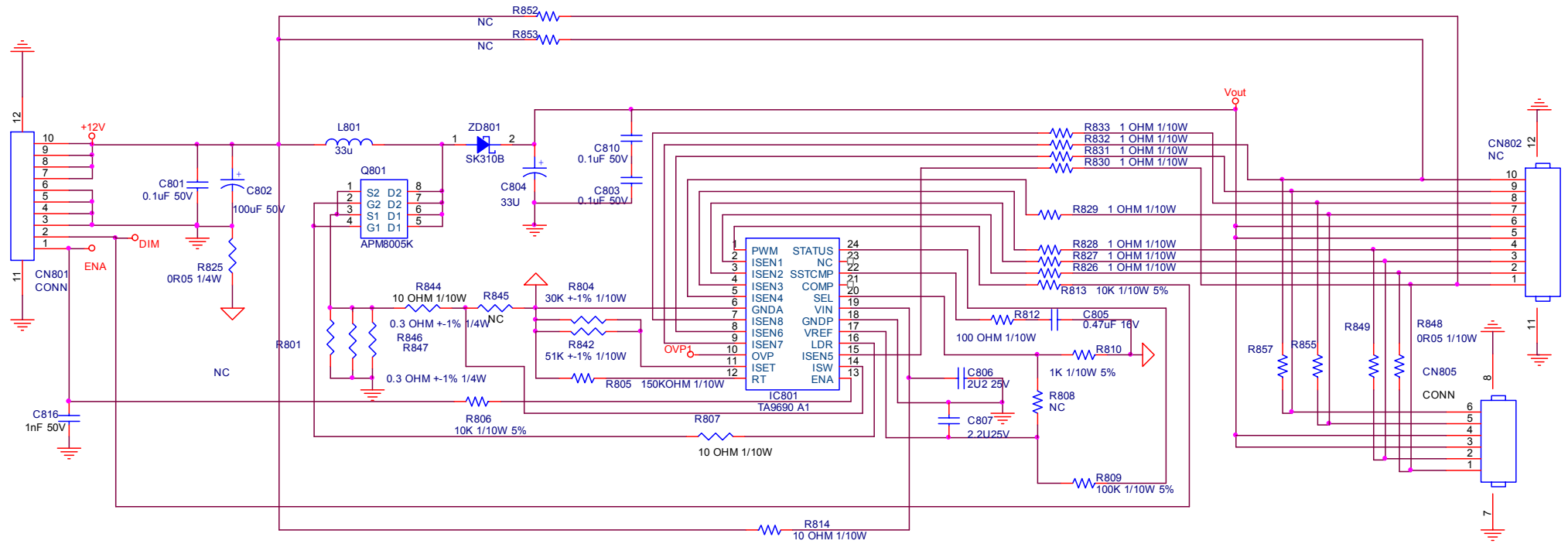

715G4704P01001004I

Remark: Parts position can be searched by using FIND function in PDF.

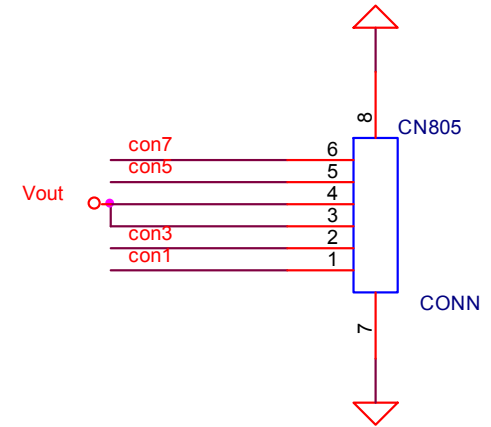
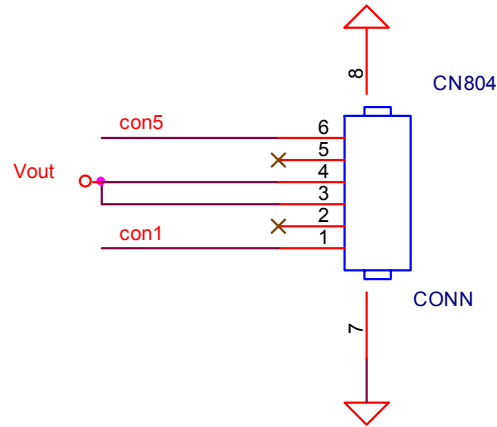
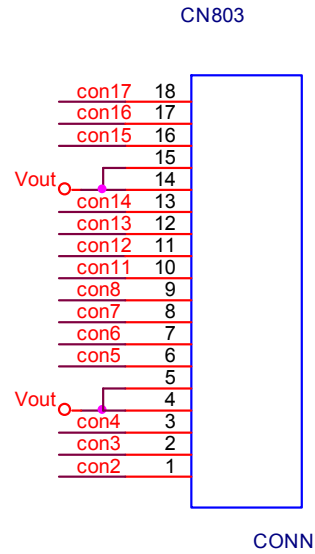

LGD LM215WF4-TLE1

SEC LTM185AT04

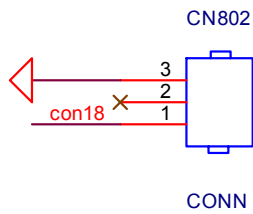
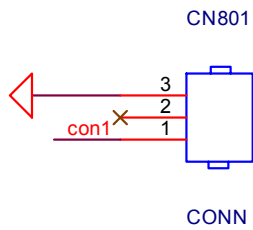

6.5 Key Board (715G3807K0G00004S)

Remark: Parts position can be searched by using FIND function in PDF.

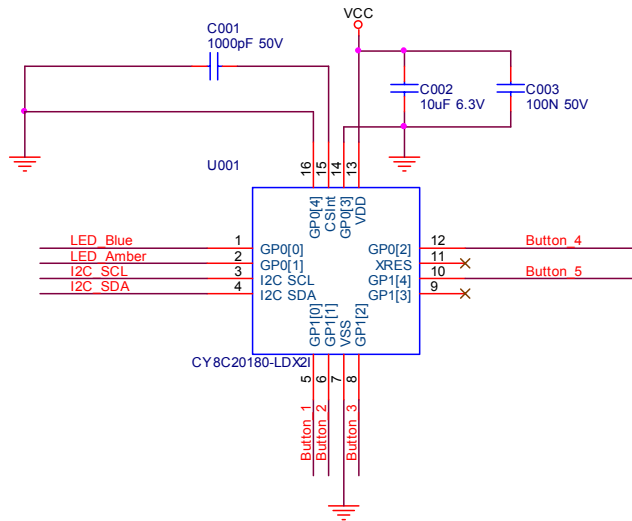

Buttons

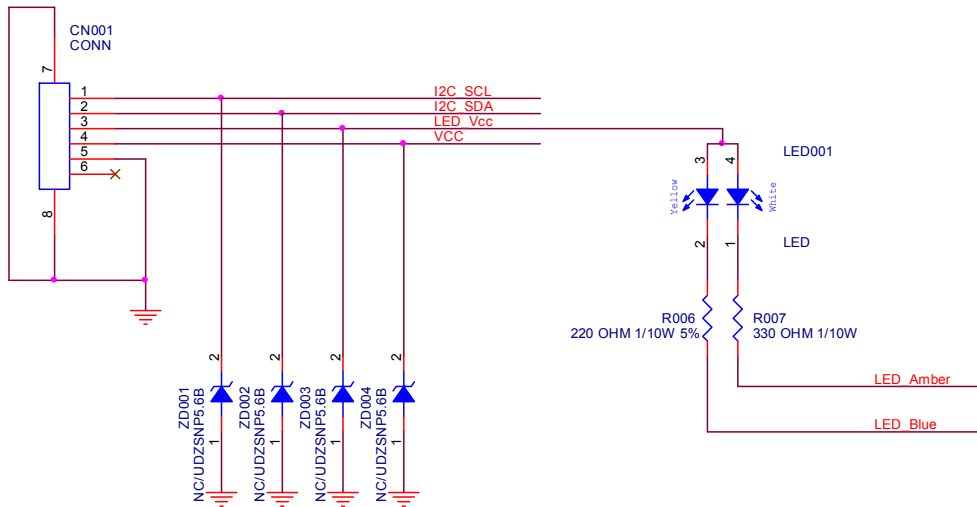
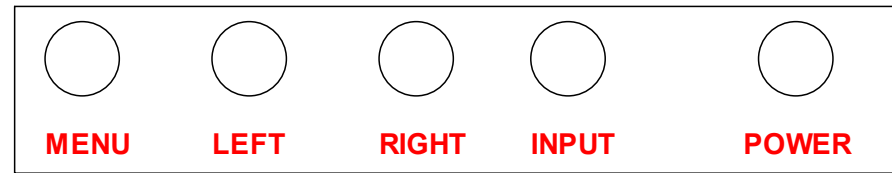
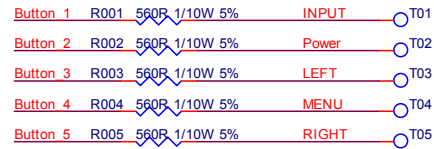

	CN401	CN001
1	KEY1	I2C SCL
2	KEY2	I2C SDA
3	POWER KEY#	LED VCC
4	LED G	VCC
5	LED R	GND
6	GND	NC
7	NC	

7.3 Inverter Board

191E2 (715G3599P01000001S)

Remark: Parts position can be searched by using FIND function in PDF.

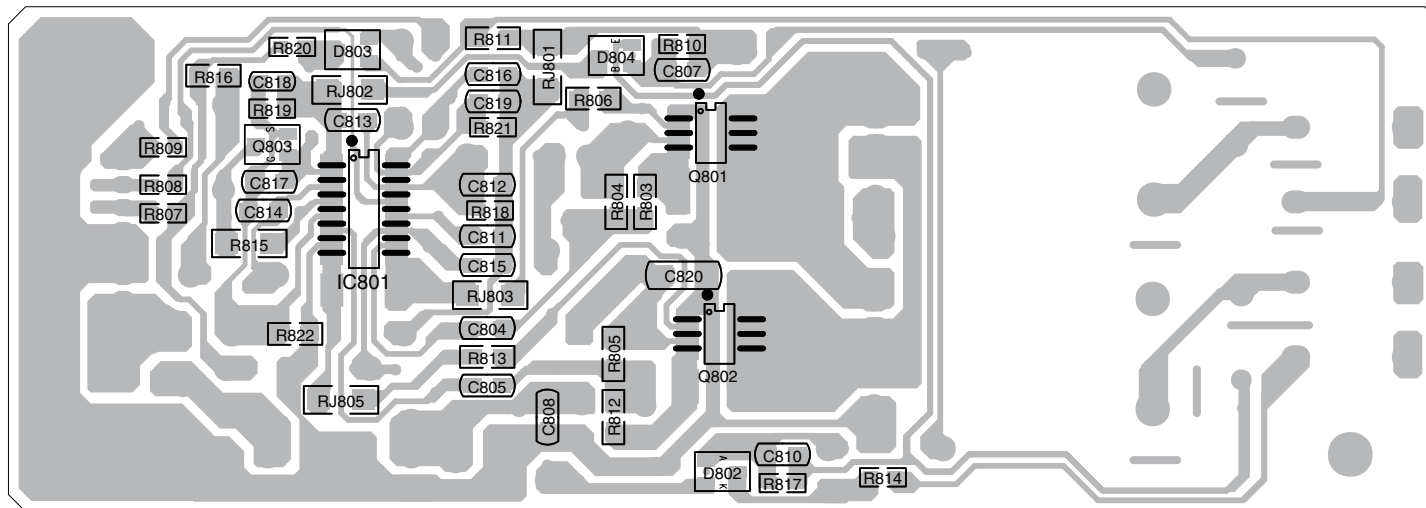
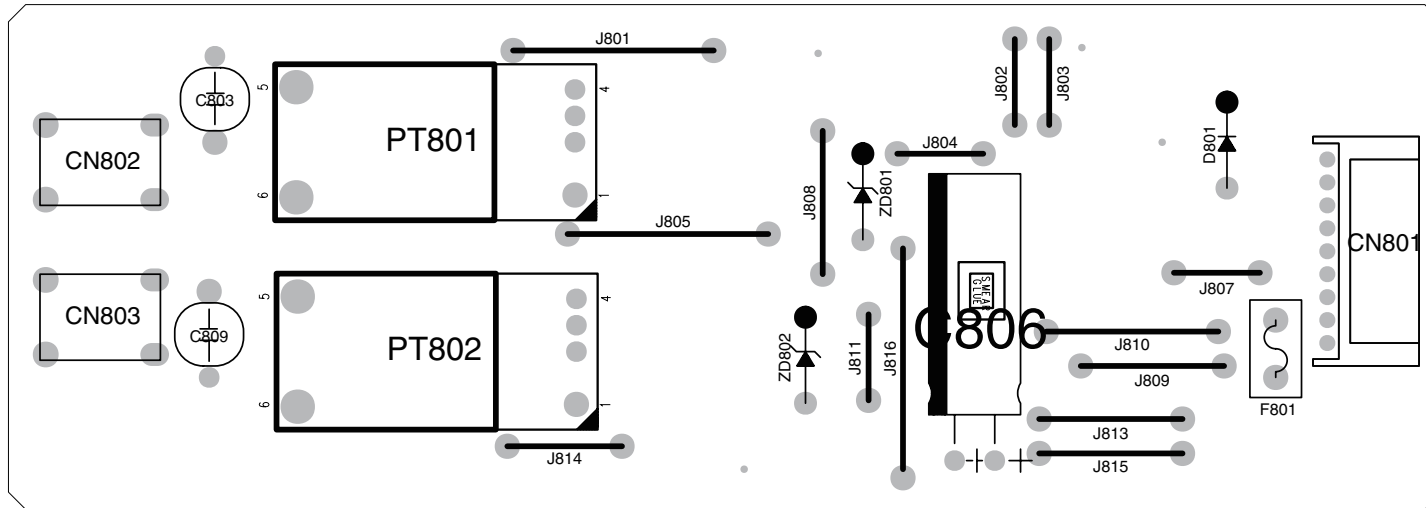

7.4 Converter Board

191EL2 (715G3823P04000004W)

Remark: Parts position can be searched by using FIND function in PDF.

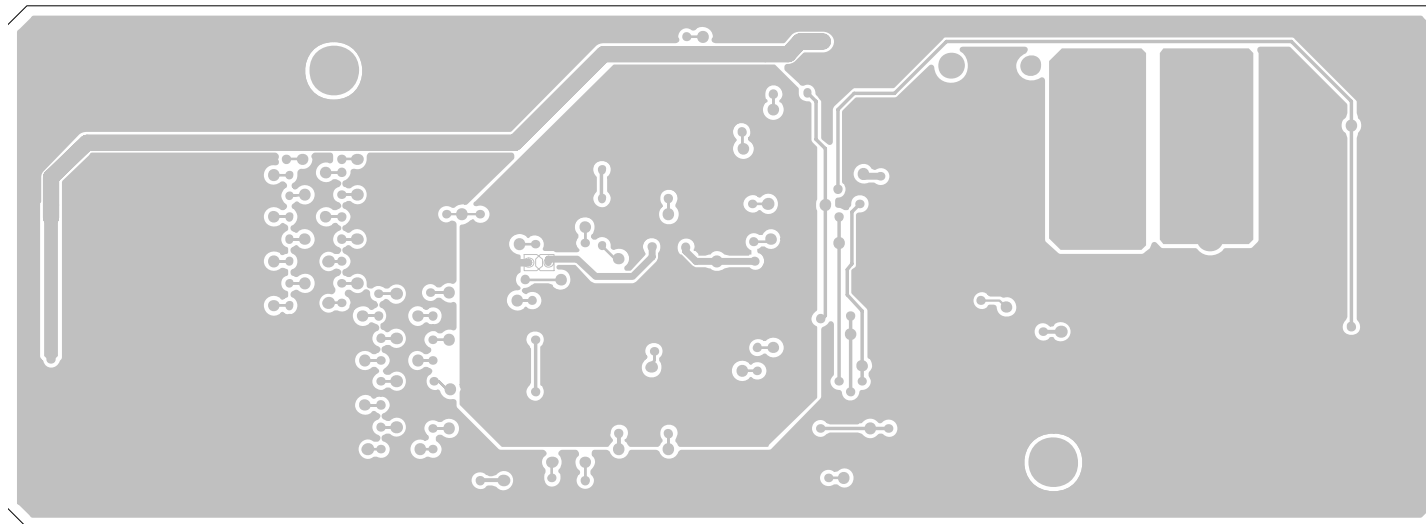
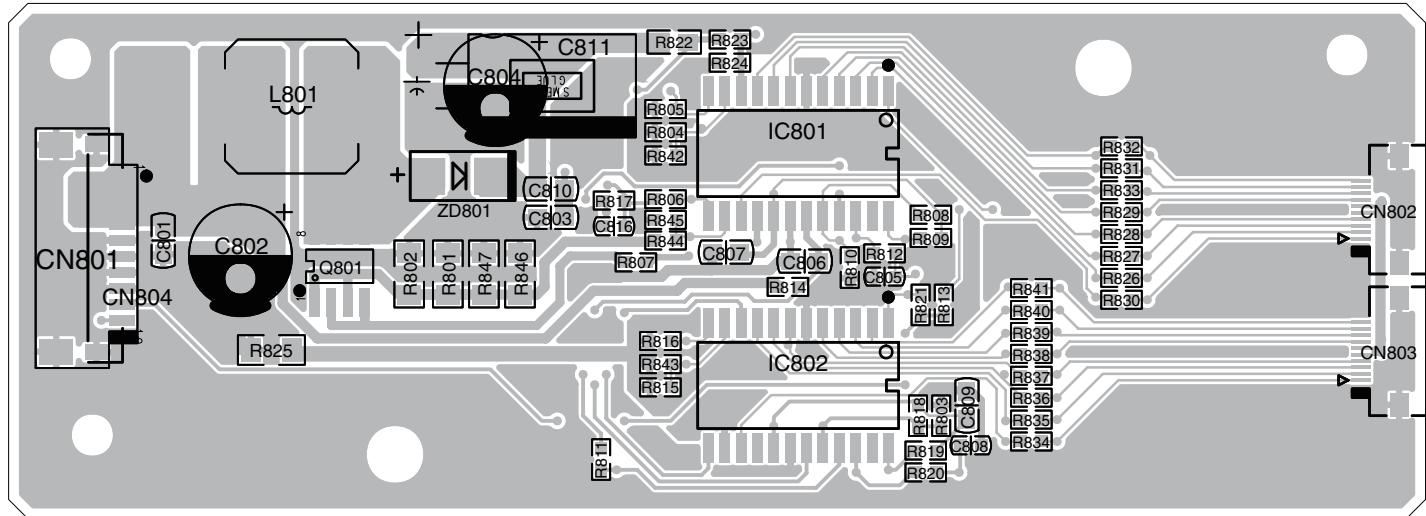

715G4137P0100004S

Remark: Parts position can be searched by using FIND function in PDF.

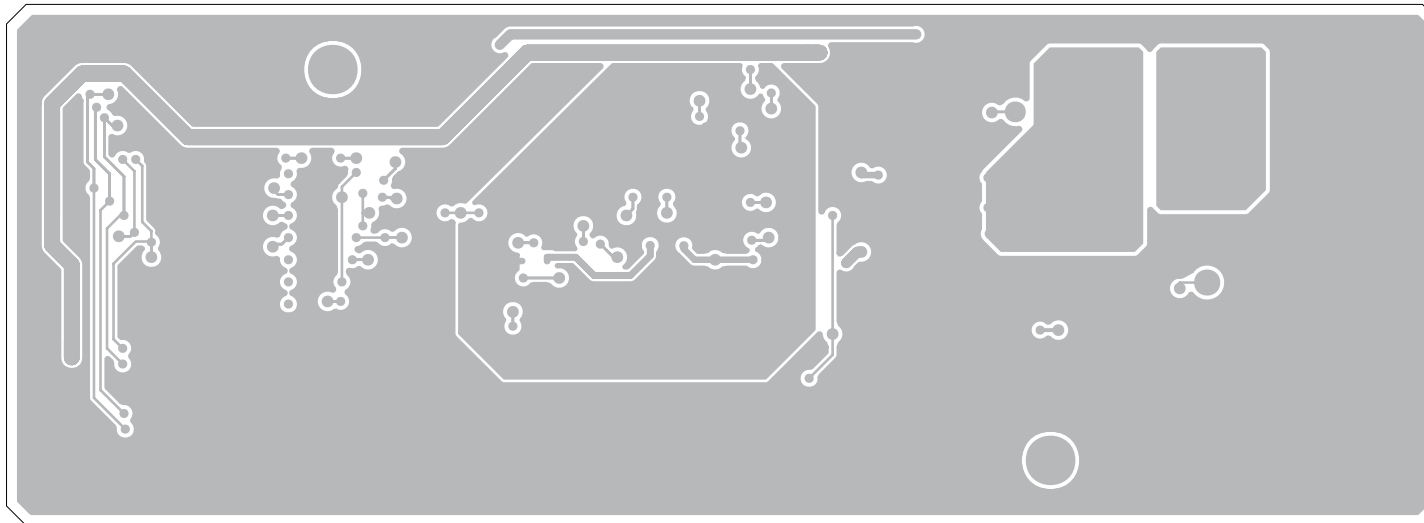
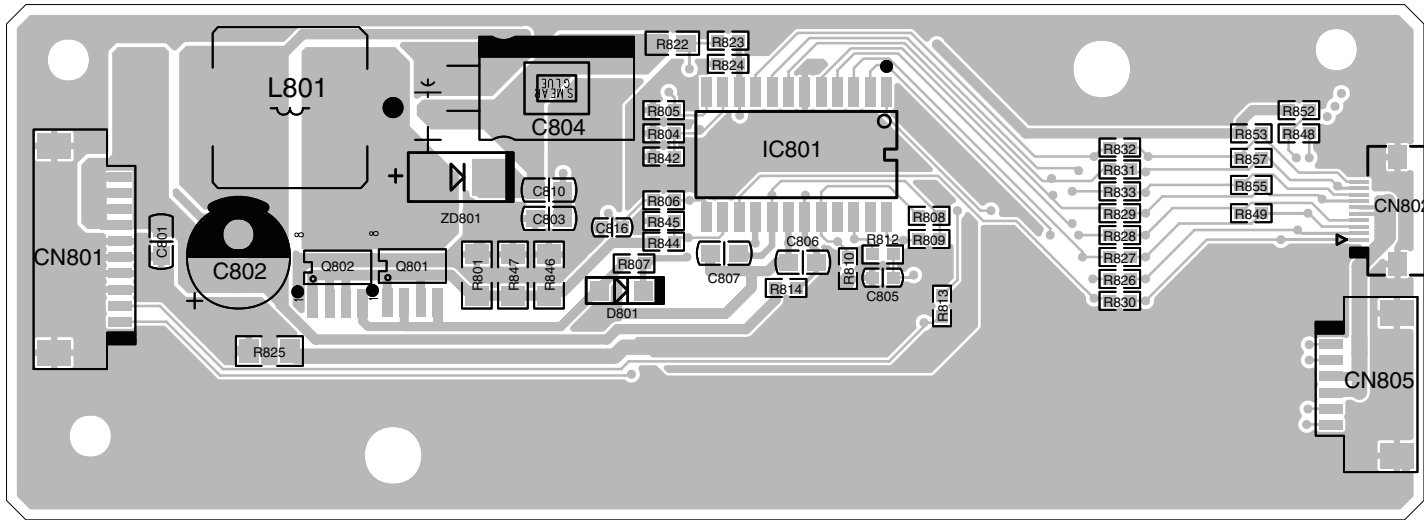

715G4704P01001004I

Remark: Parts position can be searched by using FIND function in PDF.

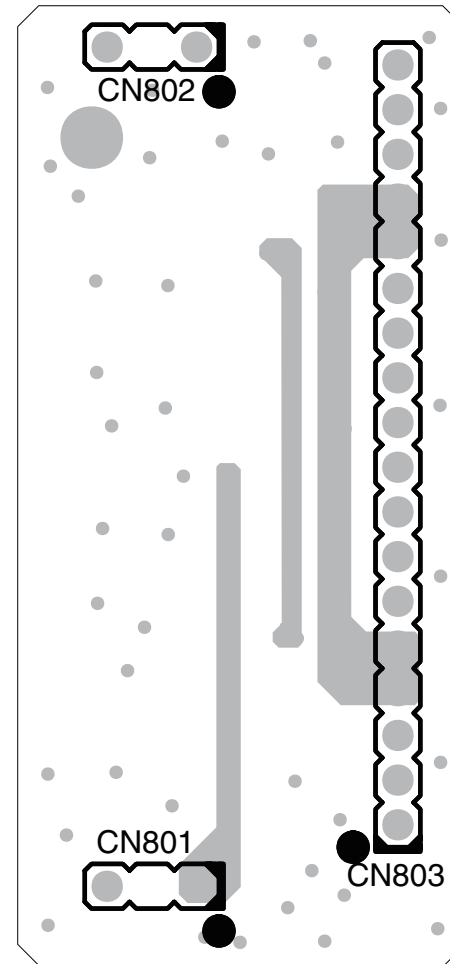
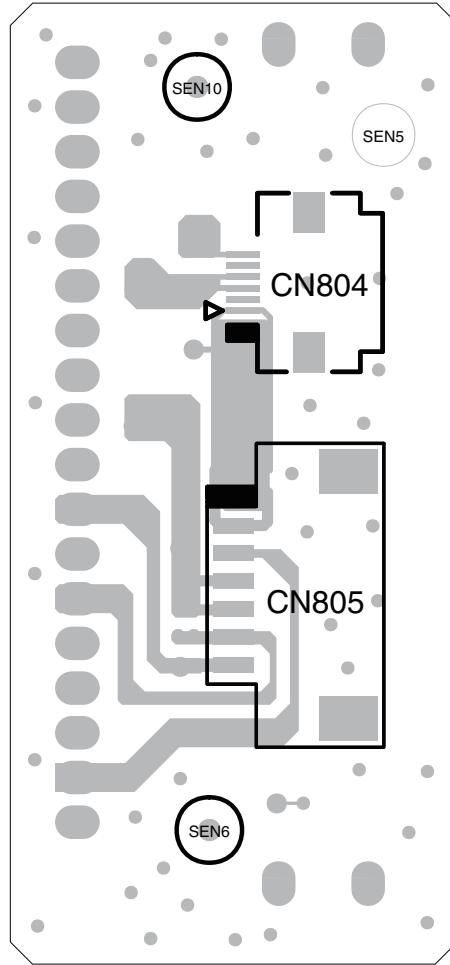

7.5 Key Board (715G3807K0G00004S)

Remark: Parts position can be searched by using FIND function in PDF.

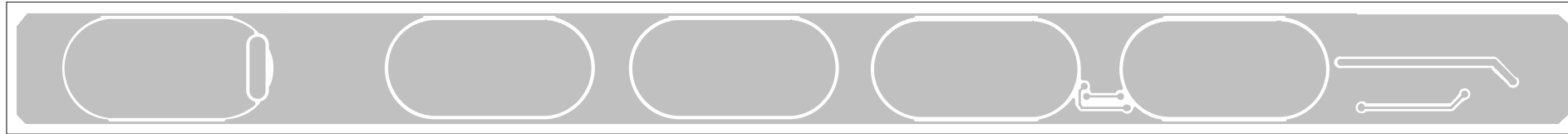
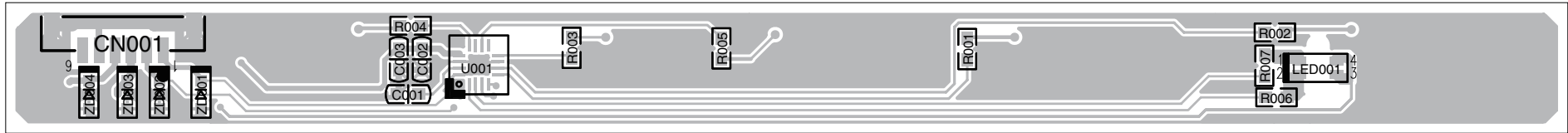

8. Wiring Diagram

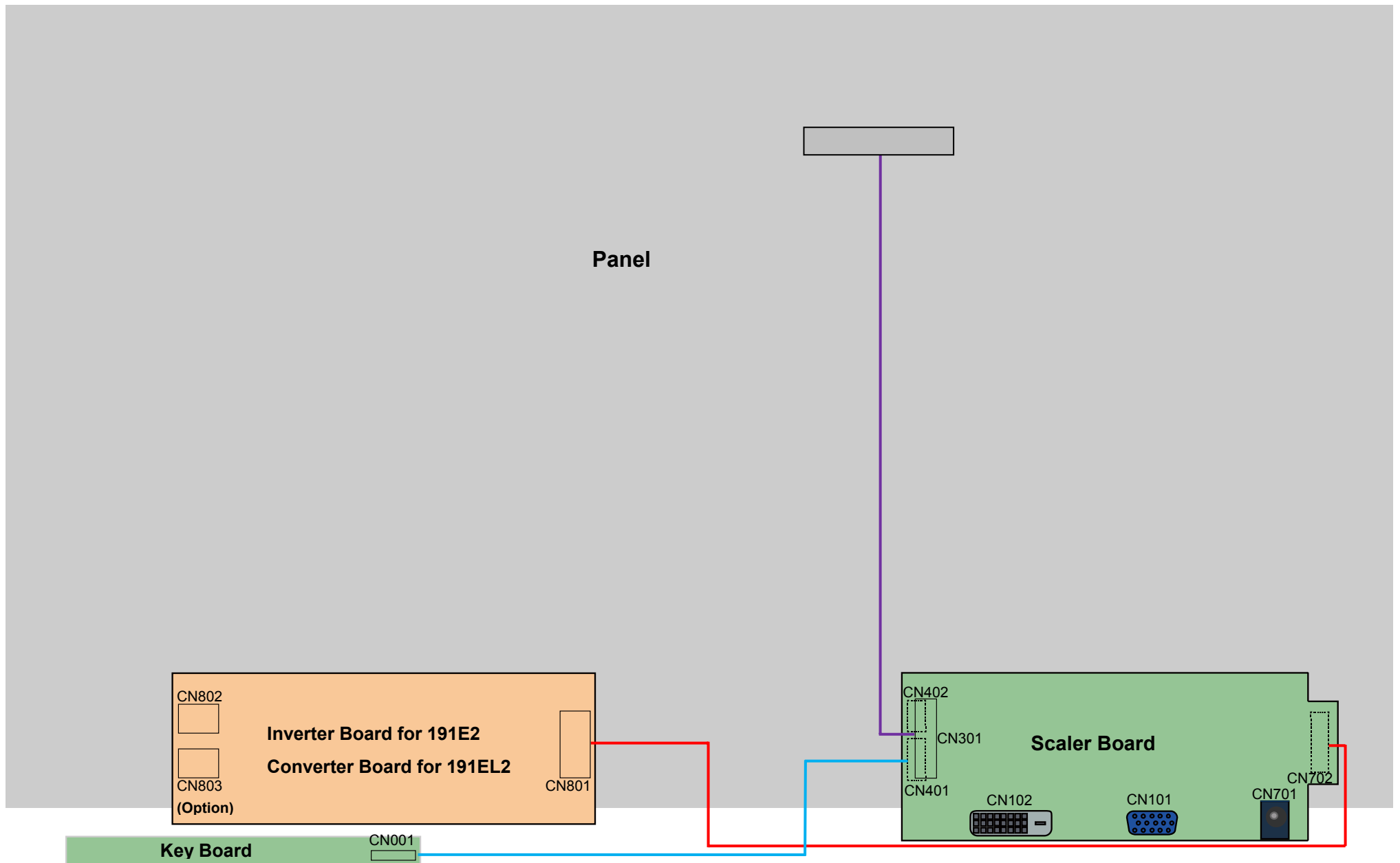

9. Scaler Board Overview

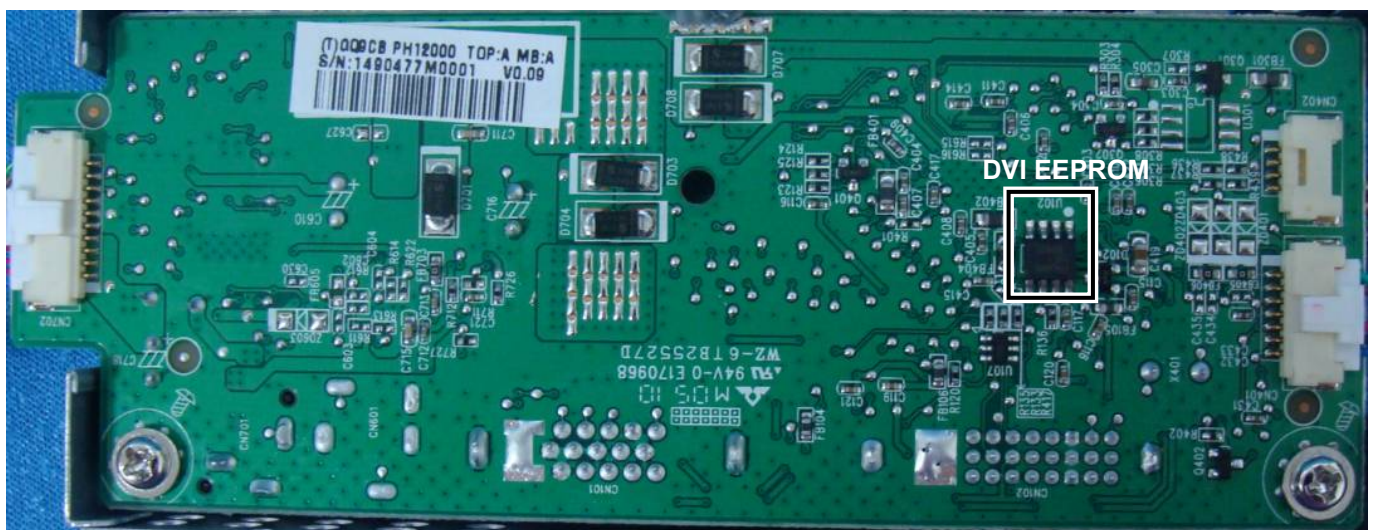
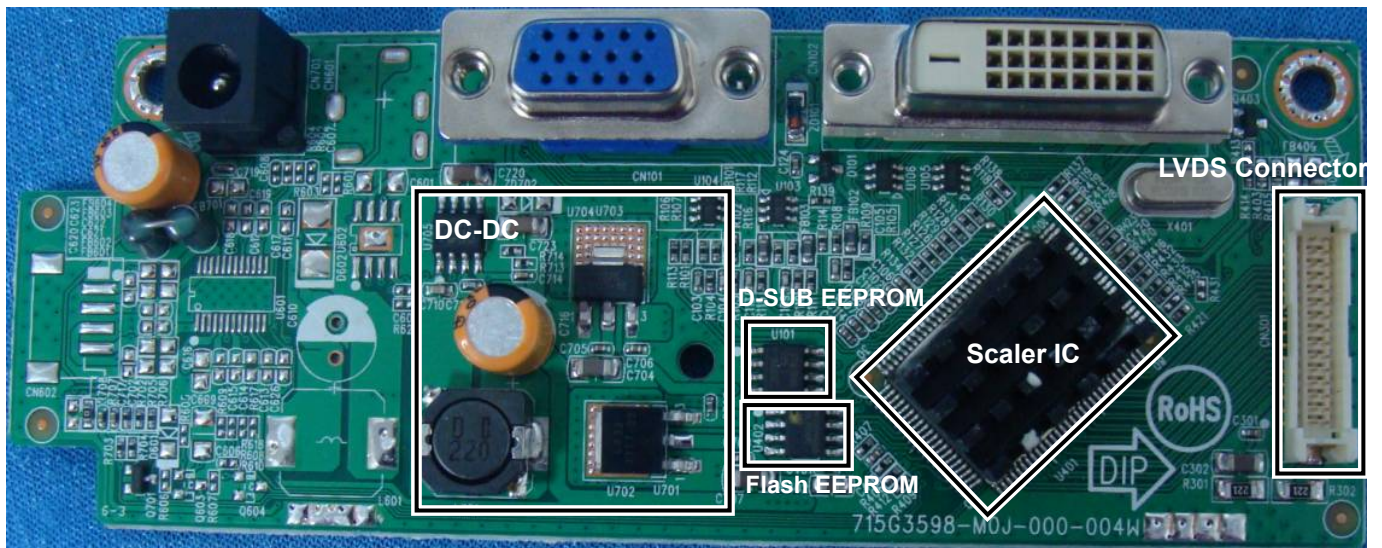

10. Mechanical Instructions



Step 2: Remove the rear cover

1. Open the latches and along the red arrowhead direction as the picture to open other latches.



Step 1: Remove the stand-base ass'y

1. Place the monitor face on a safe surface, and remove the screw to remove the stand base ass'y from the monitor.

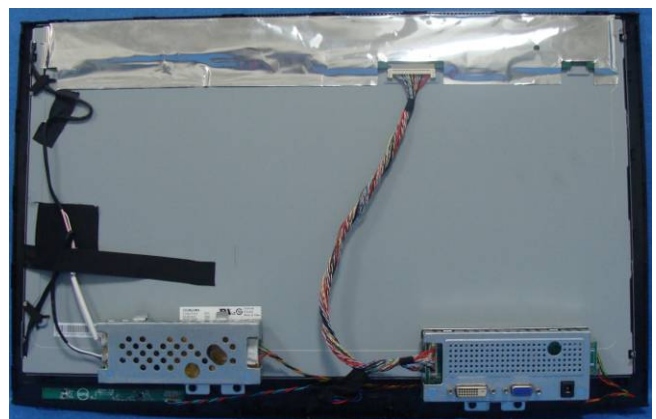

Step 3: Remove the bezel

1. Remove the Scaler Board assy.



2. Remove the Inverter Board assy.

191E2

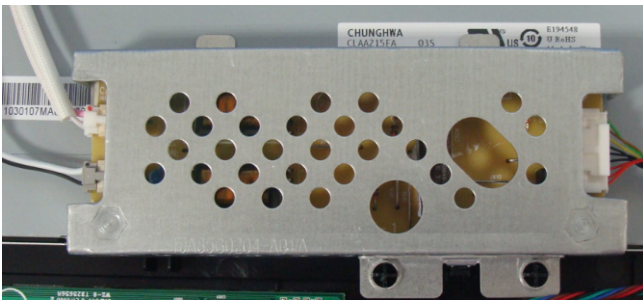

3. Remove the Converter Board assy.

191EL2

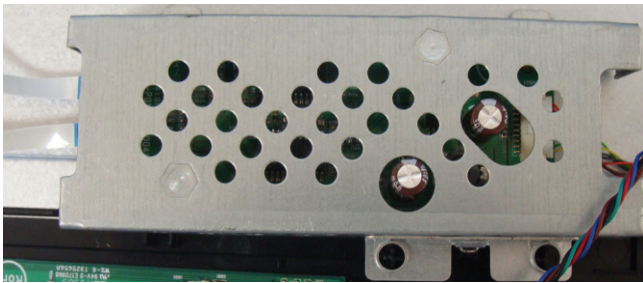

4. Disconnect the key cable.



Step 4: Remove the panel

1. Press to release left and right latches of LVDS cable and disconnect the LVDS cable.

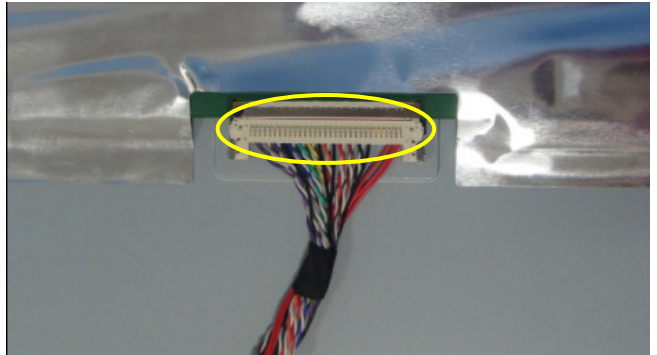

2. Disconnect the lamp connectors.

191E2

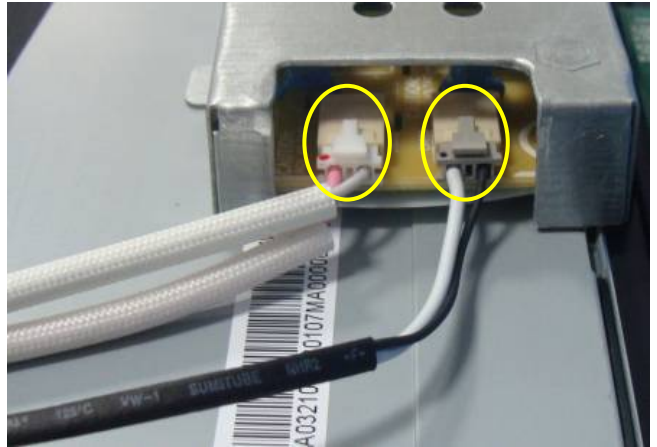

191EL2

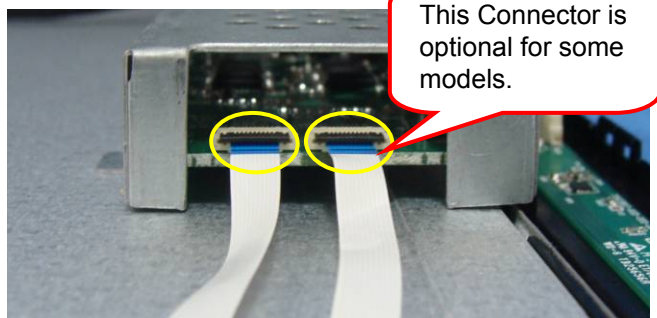



2. Remove the Inverter Board

191E2



Step 5: Remove the boards

1. Remove the Scaler Board

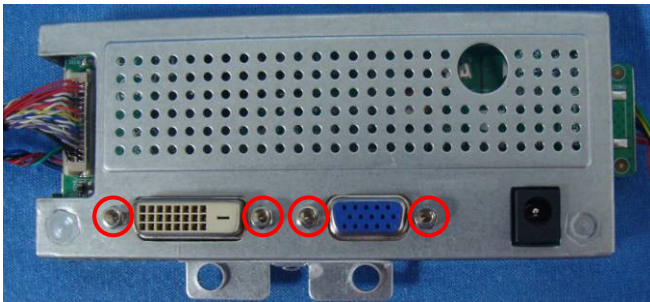

3. Remove the Converter Board

191EL2

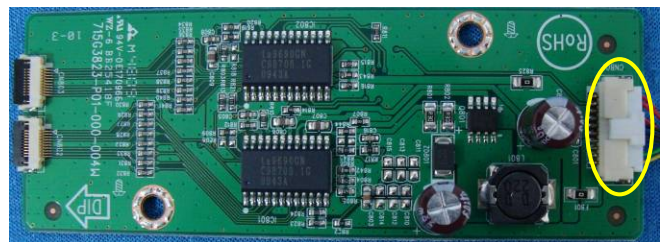
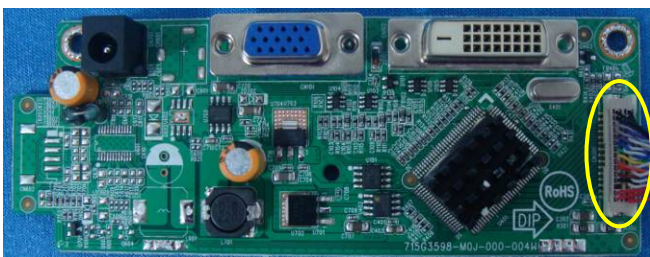

11. Repair Flow Chart

1. No Power

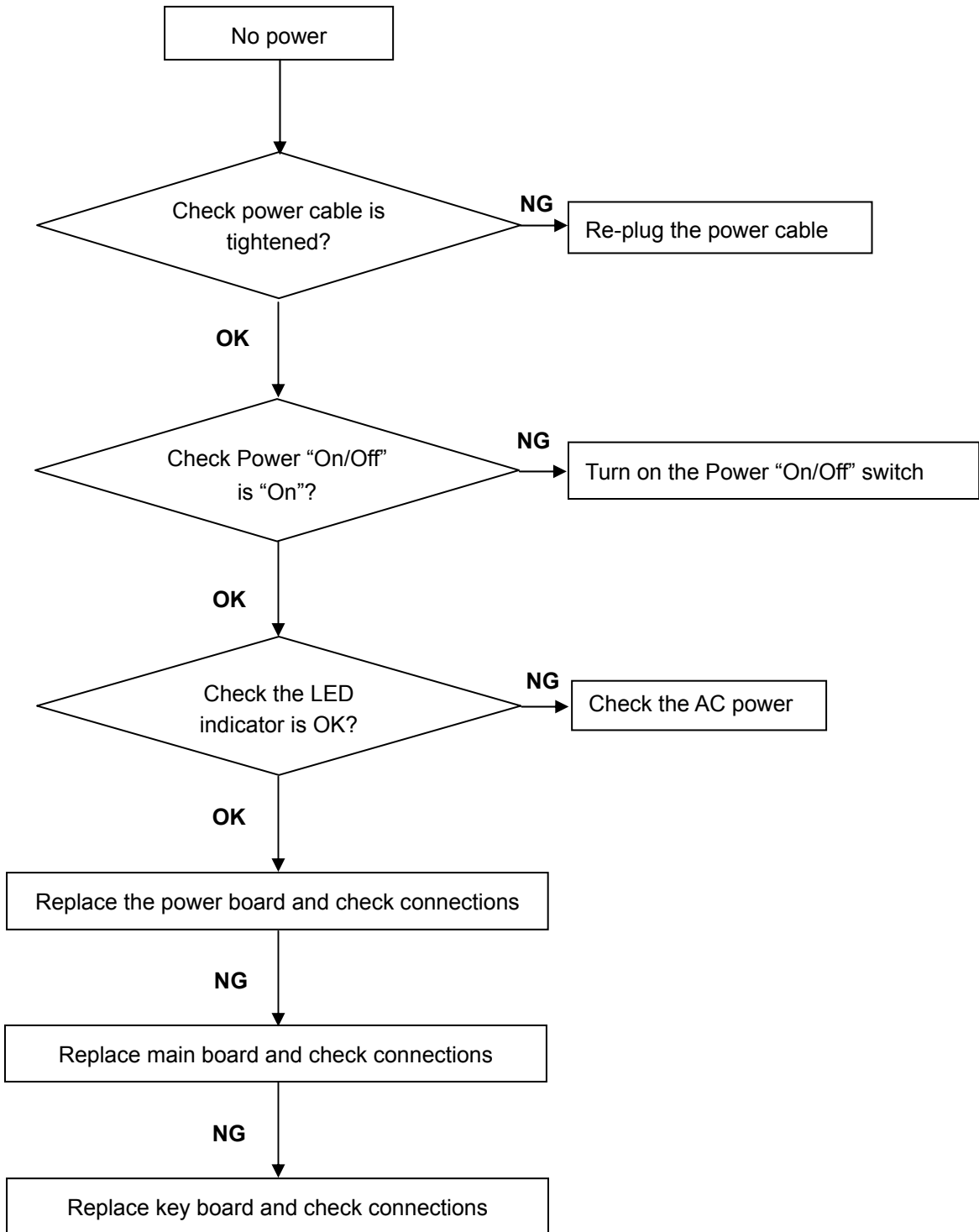

2. No Video (Power LED White)

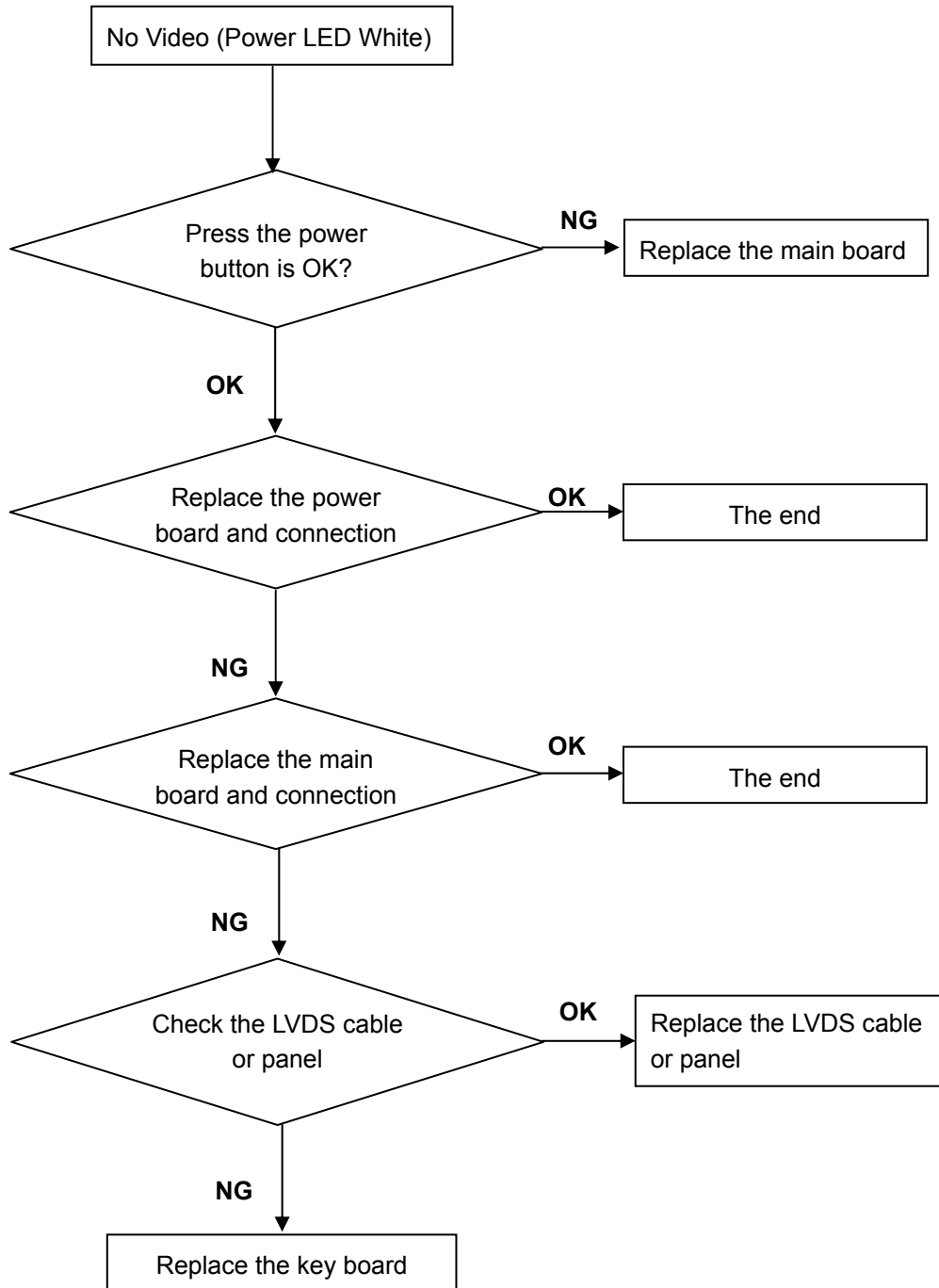

3. DIM

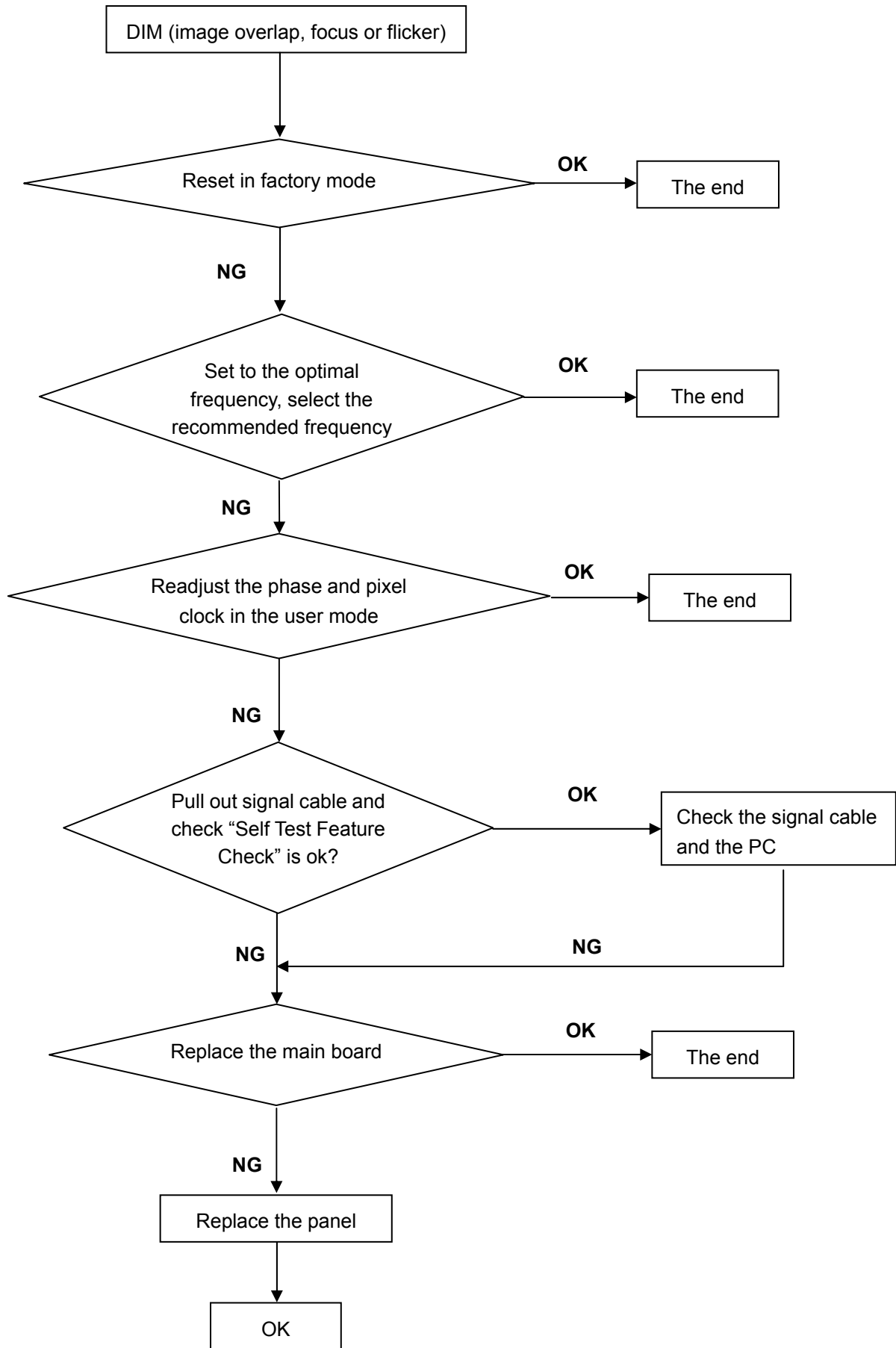

4. Color is not optimal

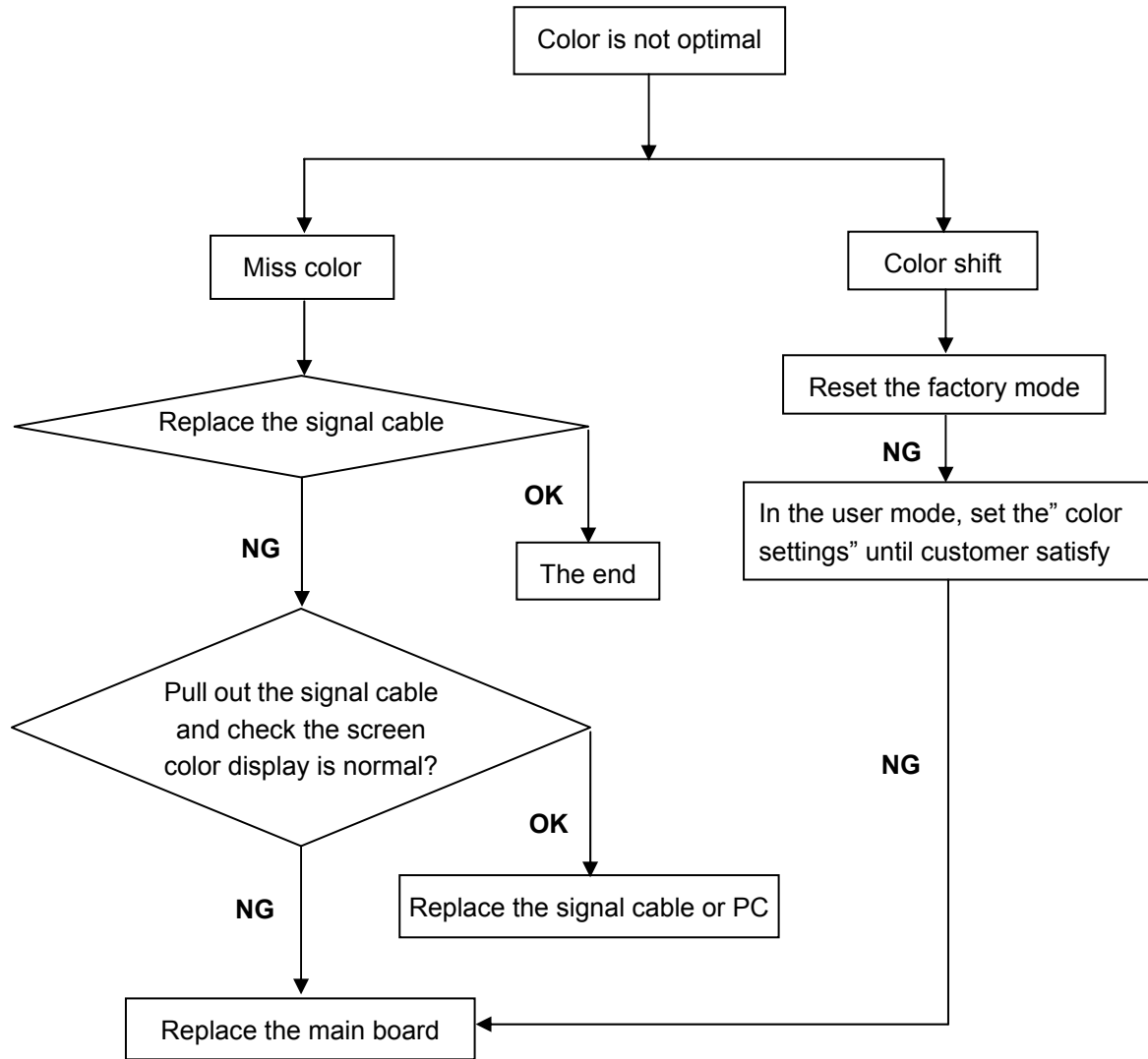

12. ISP Instruction

When do the parts, need the tools as follow:

- A. An i486 (or above) personal computer or compatible.
- B. Microsoft operation system Windows 95/98/2000/XP.
- C. "PORT95NT.exe" and "ISP_Tool V4.3.4.exe" programs
- D. ISP Board (715GT039-A) x1, Printer cablex1, VGA cable x1
- E. software

12.1 Double Click  to install the "PORT95NT.exe", and then restart the computer.

12.2. Connect the ISP board as follows:

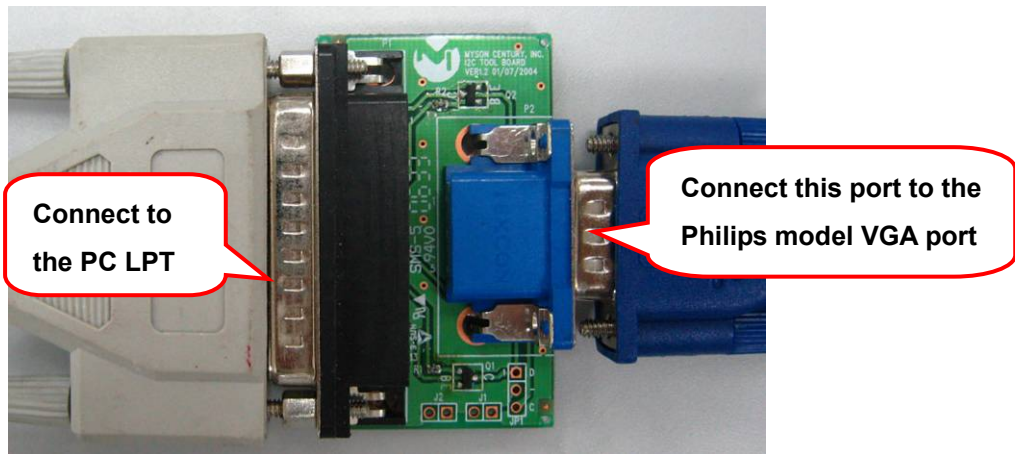

12.3 The process of ISP writing as follows (take the 221E1 for example):

1. Double-click  to running the program as follows:

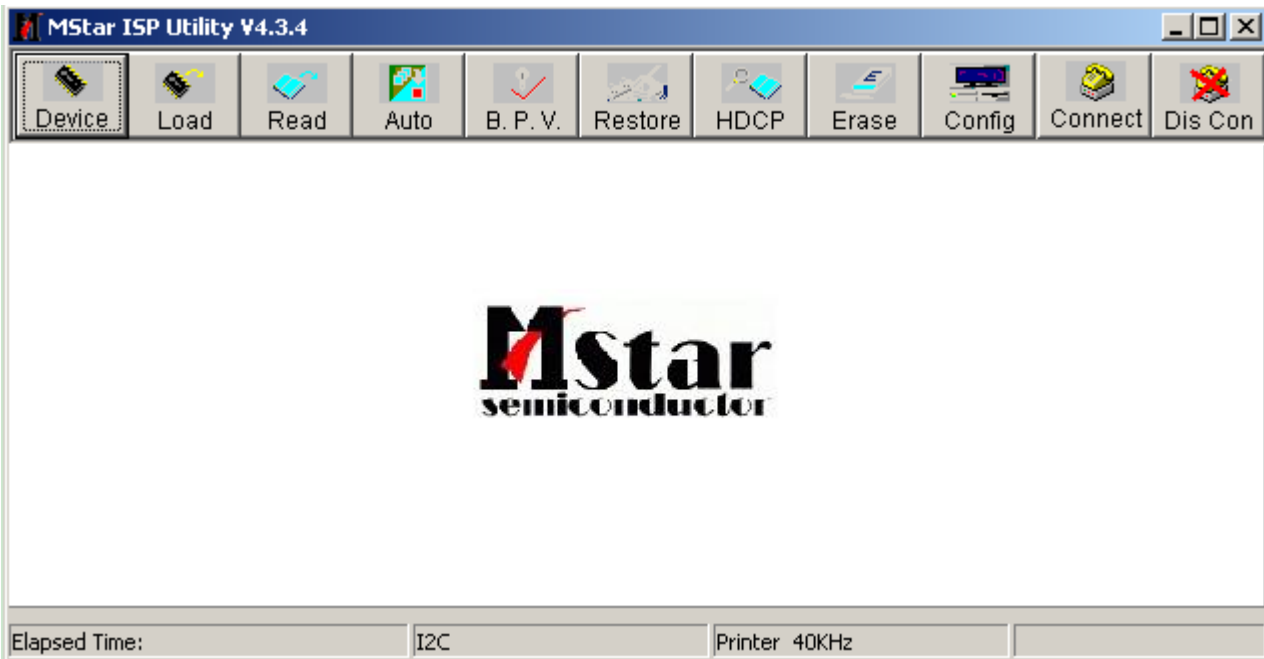

52 Meridian 2

2. Select the "Config" item, and set the parameters as below picture:

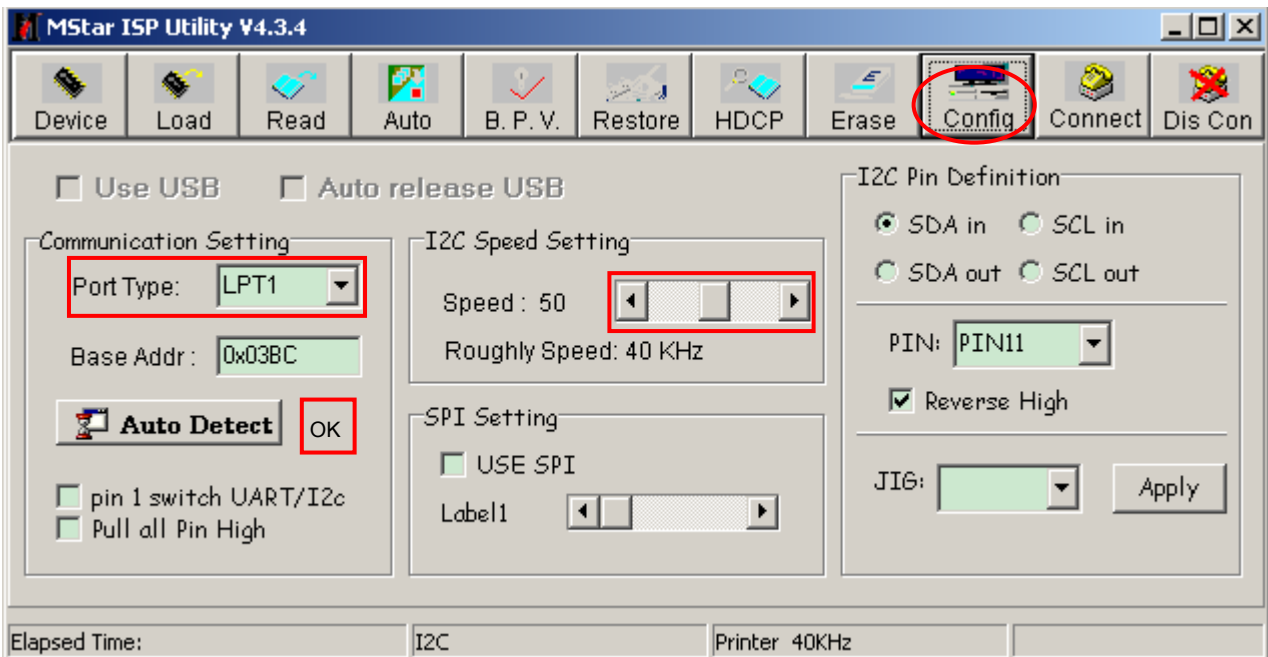

3. Select the "Device" item, and set the parameters as below picture:

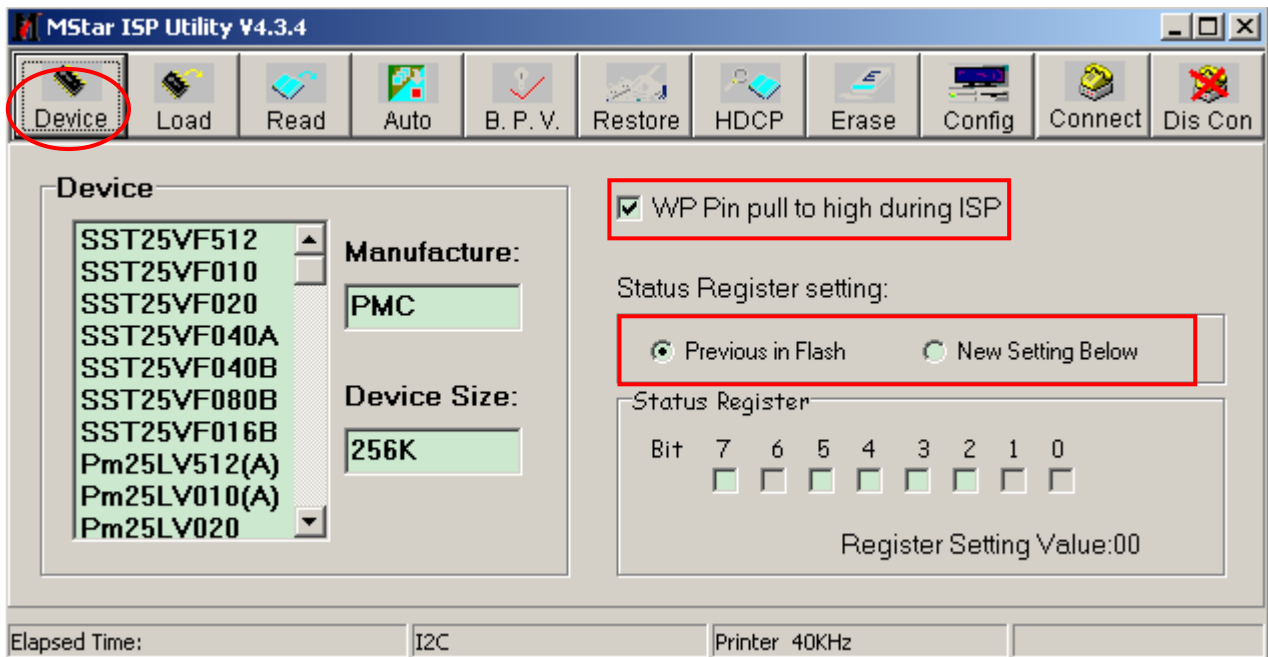

4. Select the "Connect" item, if it connect successfully, it will show "Device Type is Pm25LV020", and then click "OK".

Note: The Device Type depends on the models.

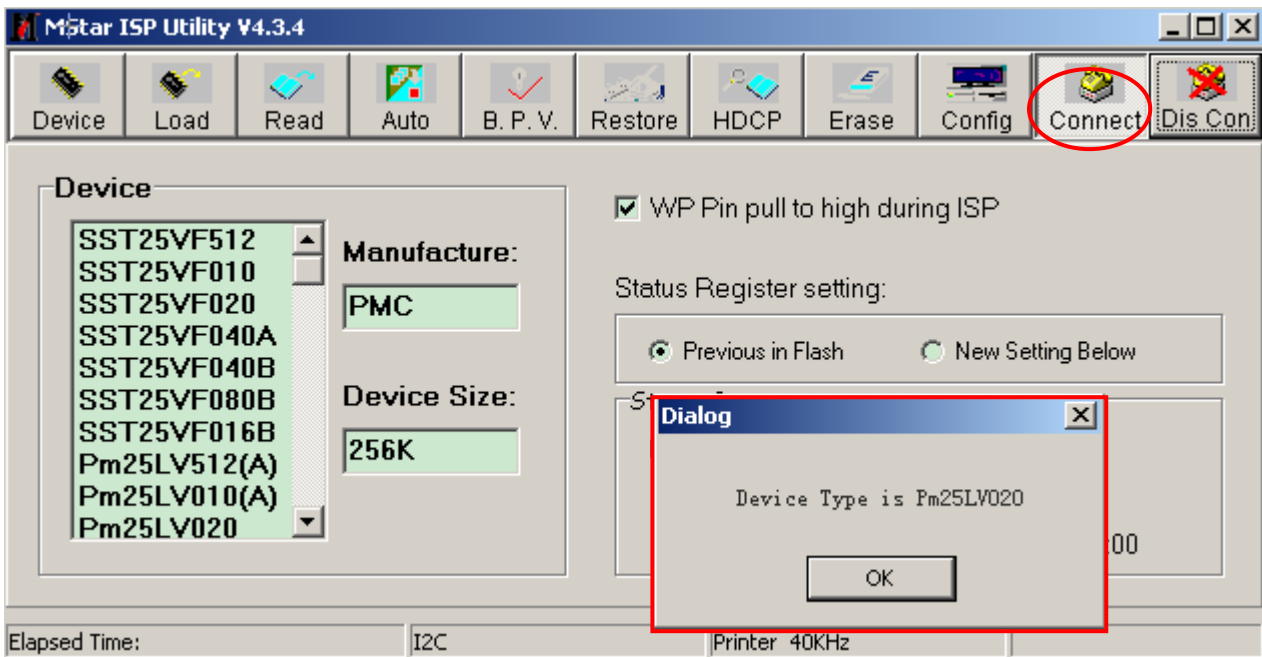

5. Select the "Read" item, and then click "Read" to select the software.

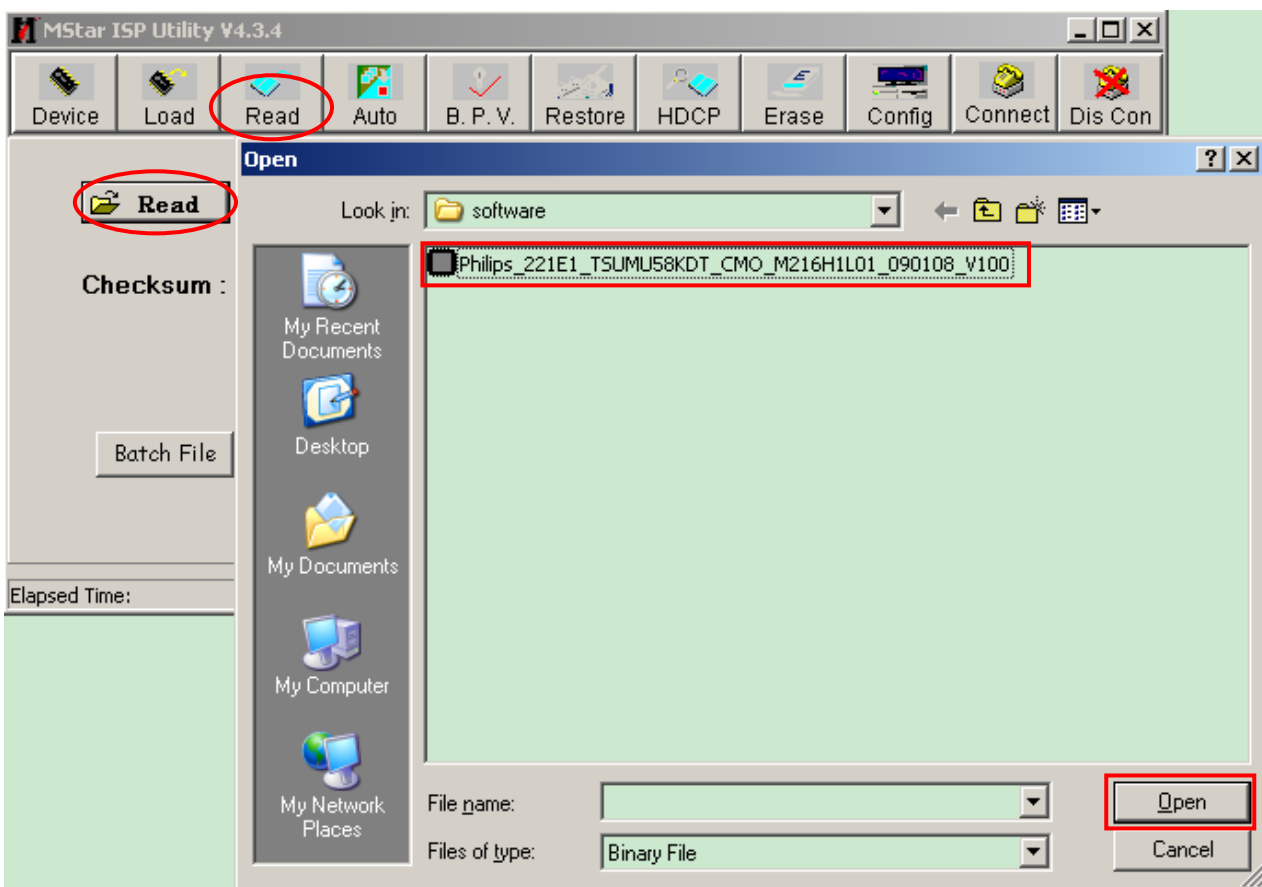

6. Click "Open", it will show the picture as below:

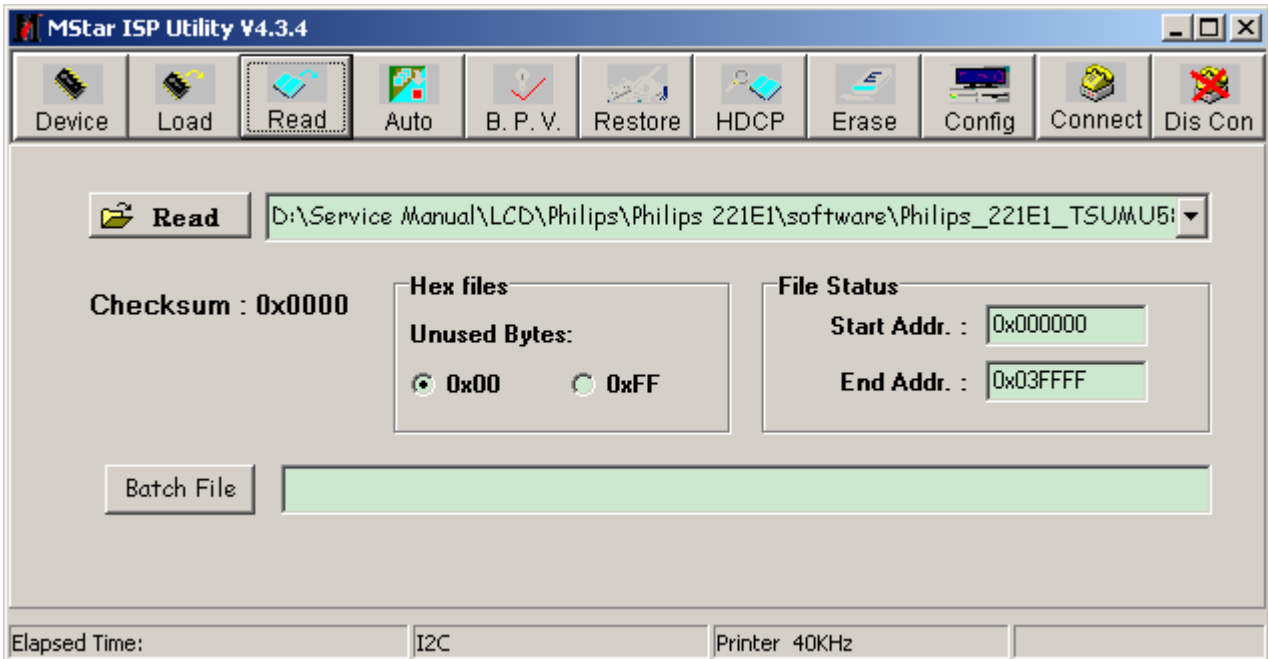

7. Select the "Restore" item, and select the "Restore Enable" to protect HDCP- KEY. The address must be set **0x03F000** which code will be protected from this address. And then set the protect range **4KB**.

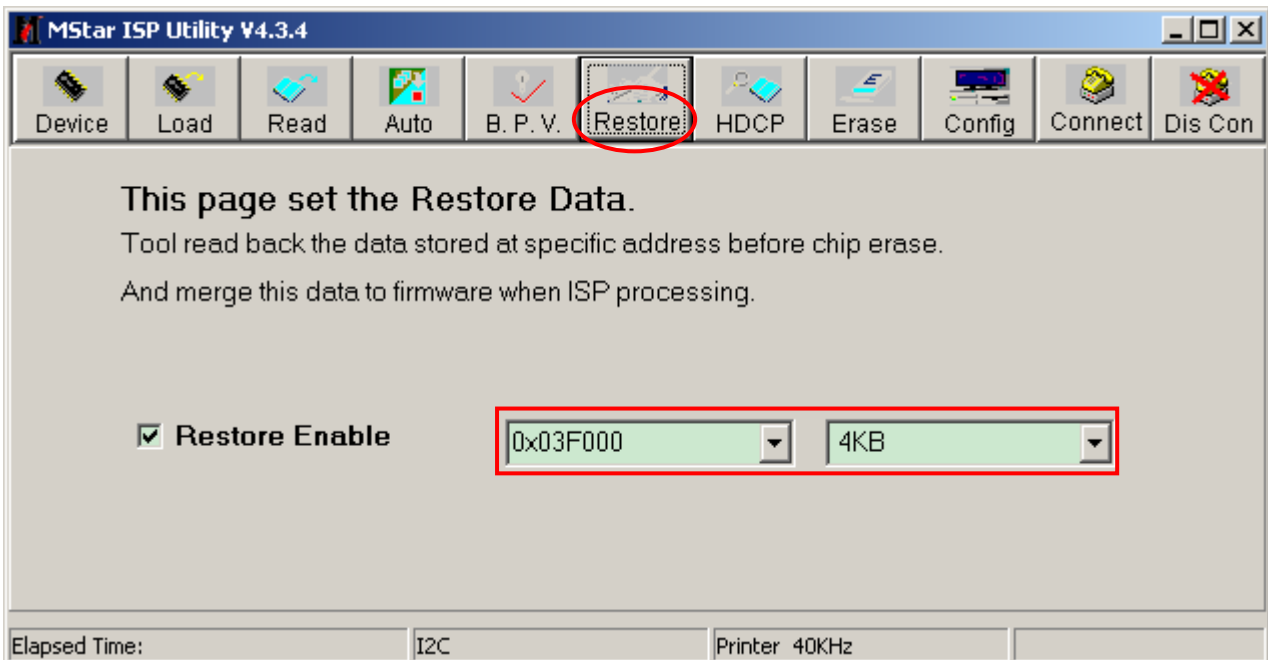

8. Select the "Auto" item, and select the "Restore Data".

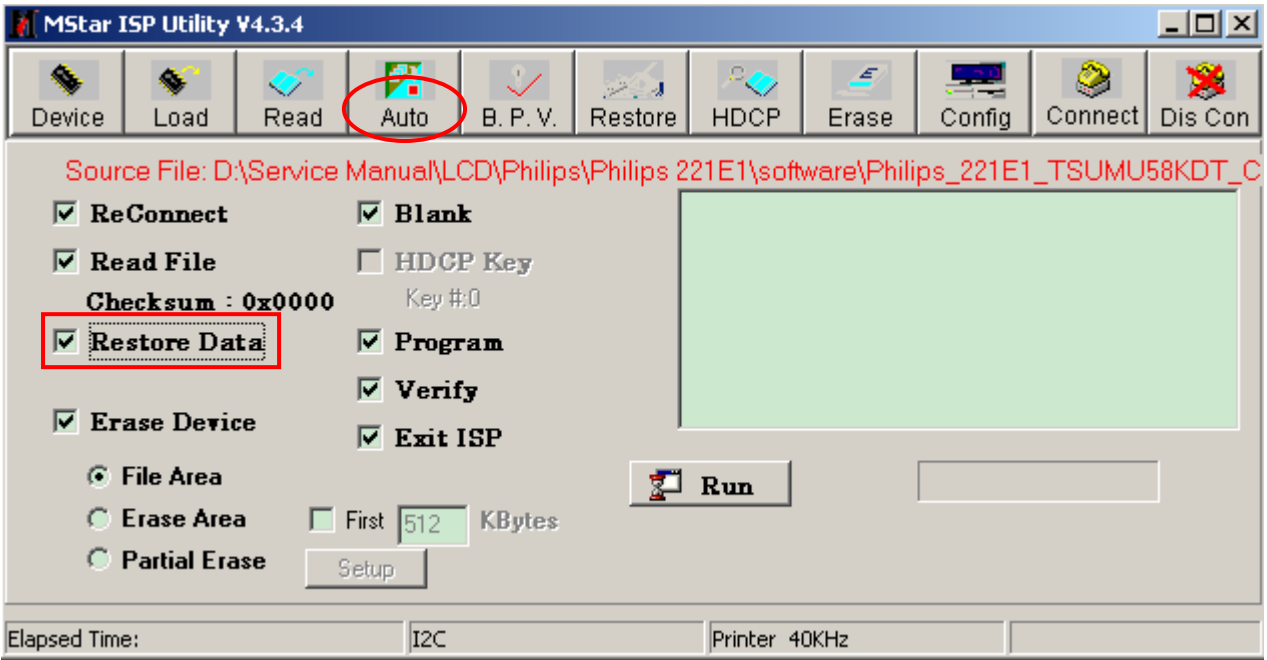

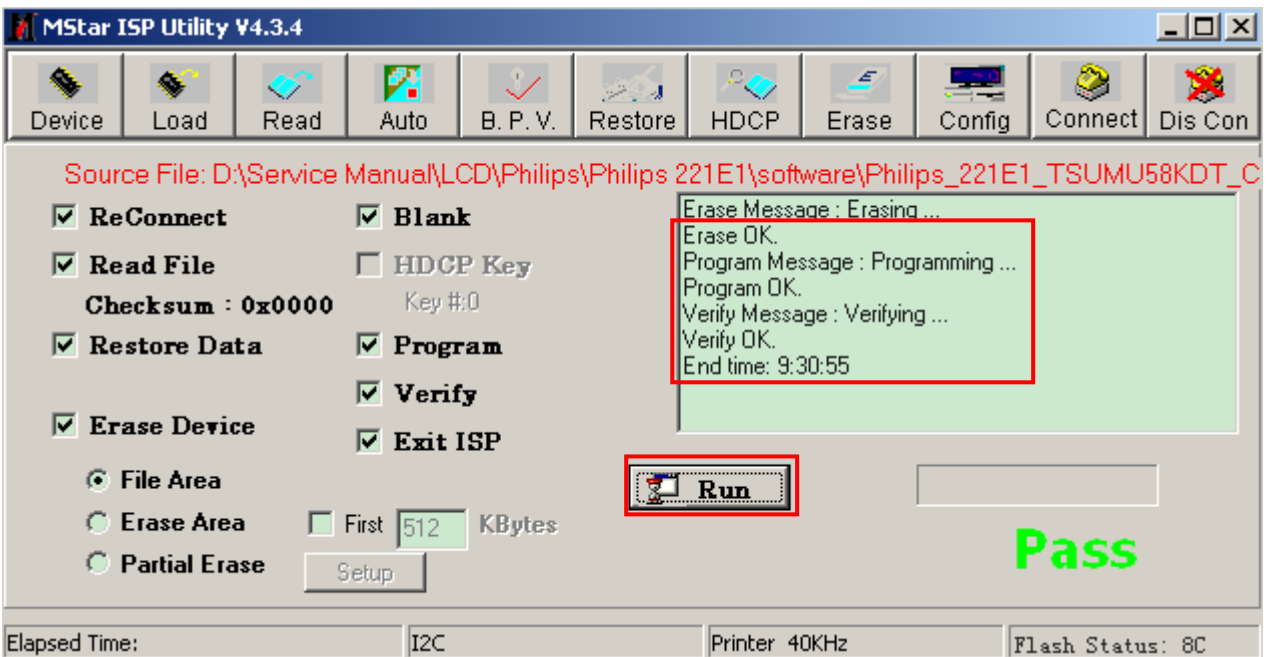

9. Click "Run", if it writes successfully, it will show as below picture:



12.4 Check the firmware version and Auto Color:

Take the 202E2 for example as below.

1. Press /▼ and /OK buttons at the same time, power on the monitor, and then press the menu again; the picture will appear on the top left corner. Choose “Input” item, and then choose “Factory”, you will enter into the factory mode.

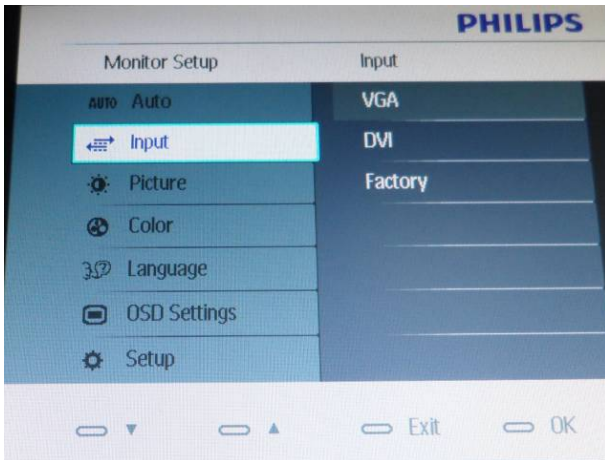

2. If the firmware version is the same as the version that you have loaded, it means the ISP writing successful.
3. Screen is 48 gray-scale, Choose “AUTO level”, PC will switch to the gray-scale screen, and press “MENU” button again, it will show “ok” meaning “AUTO COLOR” OK, as the following picture

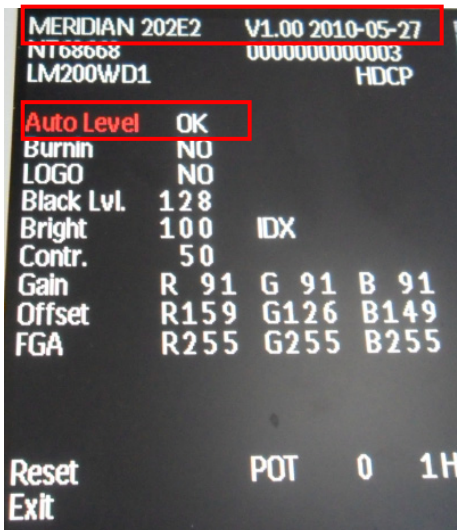

4. AC on/off to exit the factory mode.

5. Press "MENU" to enter into user mode to restore the factory setting. Otherwise, monitor will not be able to save setting. If not save the setting, when AC ON/OFF, it will can't find the boot LOG from the screen. As the below pictures:

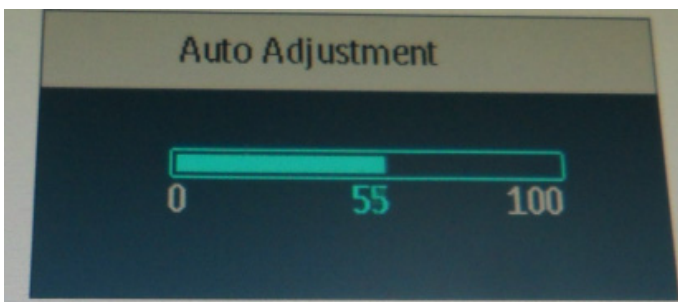
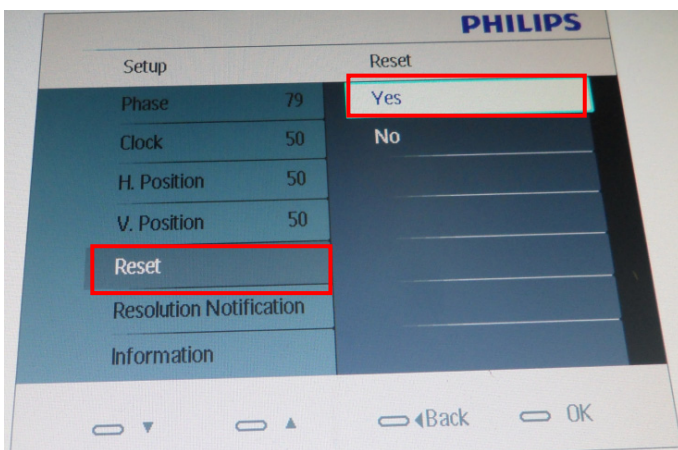
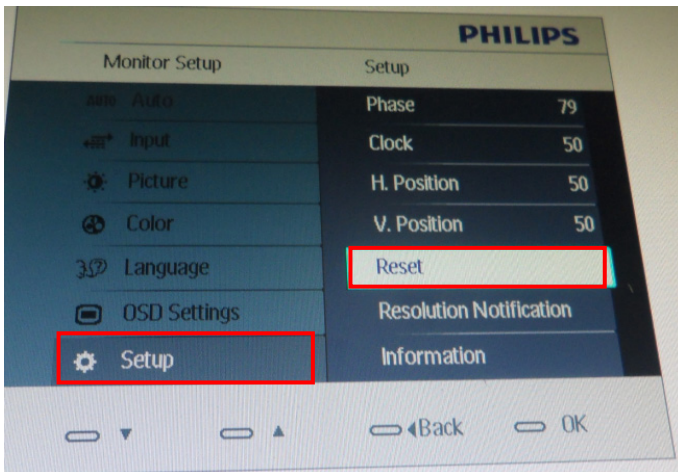

Note: If DVI no picture or VGA can't be adjusted to the best resolution, please rewrite EDID.

13. DDC Instruction

General

DDC Data Re-programming

In case the main EEPROM with Software DDC which store all factory settings were replaced because a defect repaired monitor' the serial numbers have to be re-programmed.

It is advised to re- soldered the main EEPROM with Software DDC from the old board onto the new board if circuit board have been replaced, in this case the DDC data does not need to be re-programmed.

Additional information about DDC (Display Data Channel) may be obtained from Video Electronics Standards Association (VESA). Extended Display Identification Data (EDID) information may be also obtained from VESA.

1. An i486 (or above) personal computer or compatible.
2. Microsoft operation system Windows 95/98/2000/XP.
3. "PORT95NT.exe, TPVDDC5.6.exe" program.
4. EDID Board (715GT034-B) x1,
5. Printer cablex1, VGA cable x 1, DVI-D cable x 1, 12V DC power source
6. EDID data

13.1. Install the "PORT95NT.EXE", and restart the computer.

The process of installing "PORT95NT" has been specified in, so it will not be specified again. If you have any problem, please read it.

13.2 Connect the DDC Board as follow:

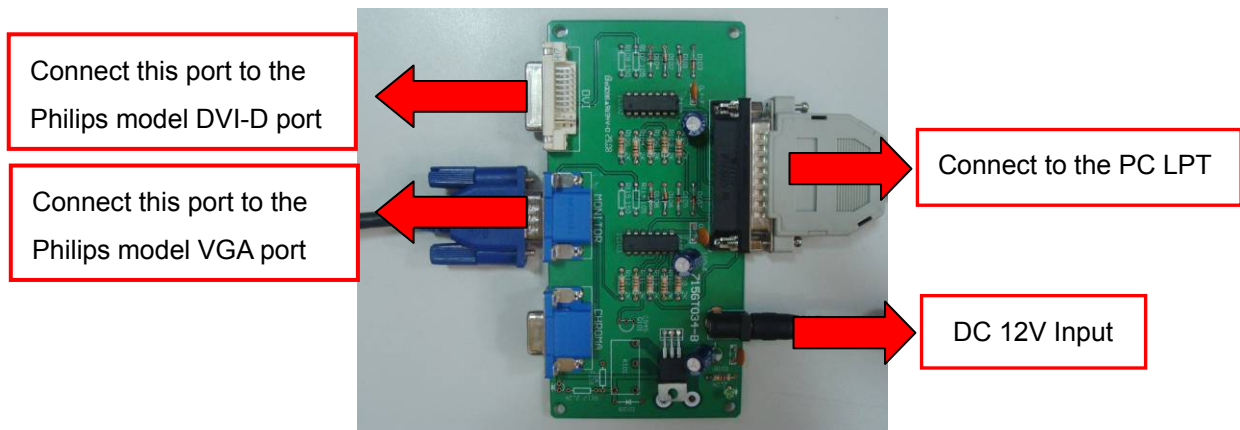

Note:

If the VGA is NG, please try to cut off the 5th pin of the VGA connector.

If the DVI is NG, please try to cut off the 14th pin of the DVI connector.



1. Rename the EDID data to “wa”, “wd”.
2. Put the “wa” and “wd” into a new folder, and then create another new folder named “ddc” (It must be “ddc” instead of other names).

Step1: **Must** put the “ddc” folder and “TPVDDC5.6.exe” into the **same** folder.

Step2: **Must** copy the folder which contains EDID data and “config” to “ddc” folder.

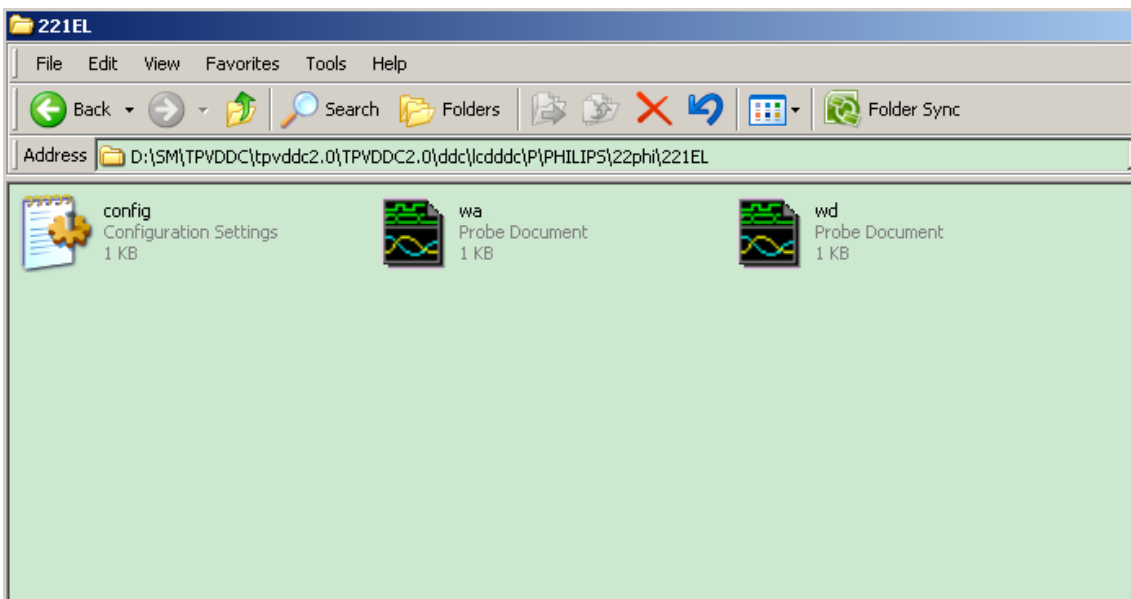
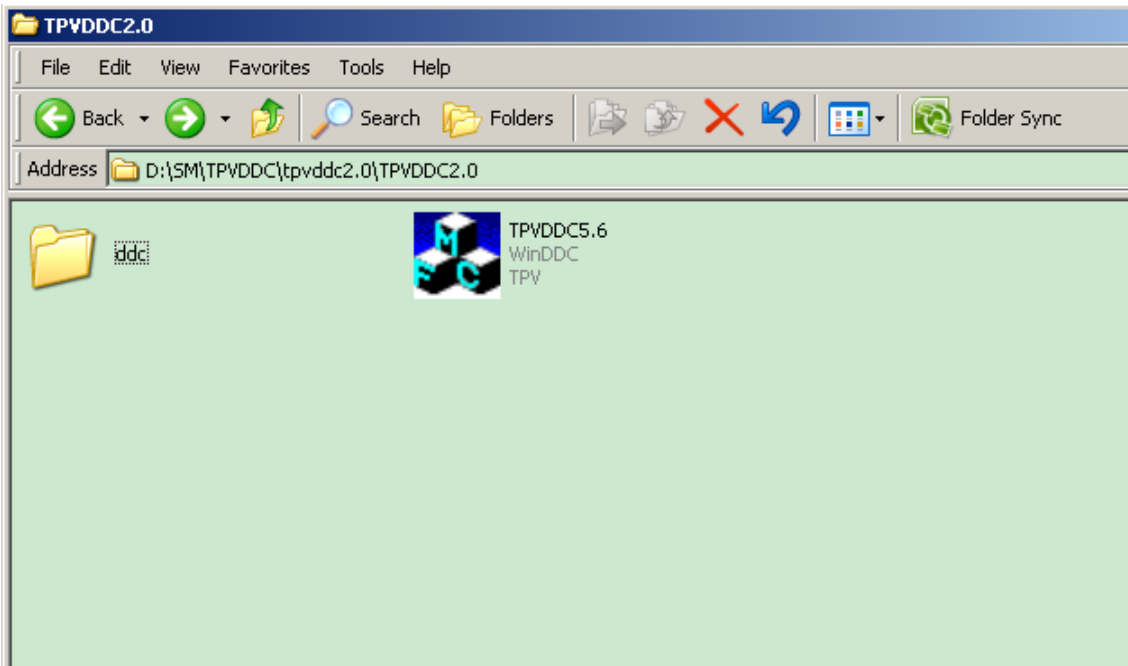

3. Double-click , appear as follow :

Take the 221EL2 for example:

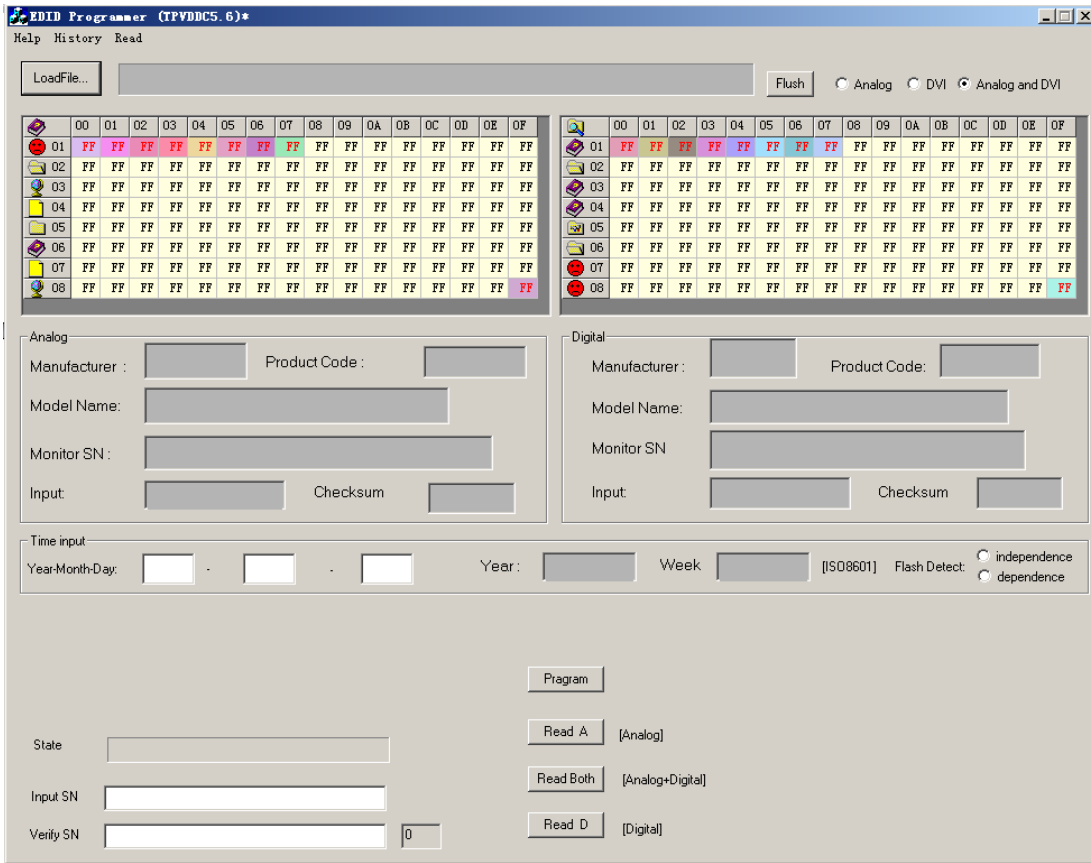

4. Click "LoadFile", it will show the picture as follow:

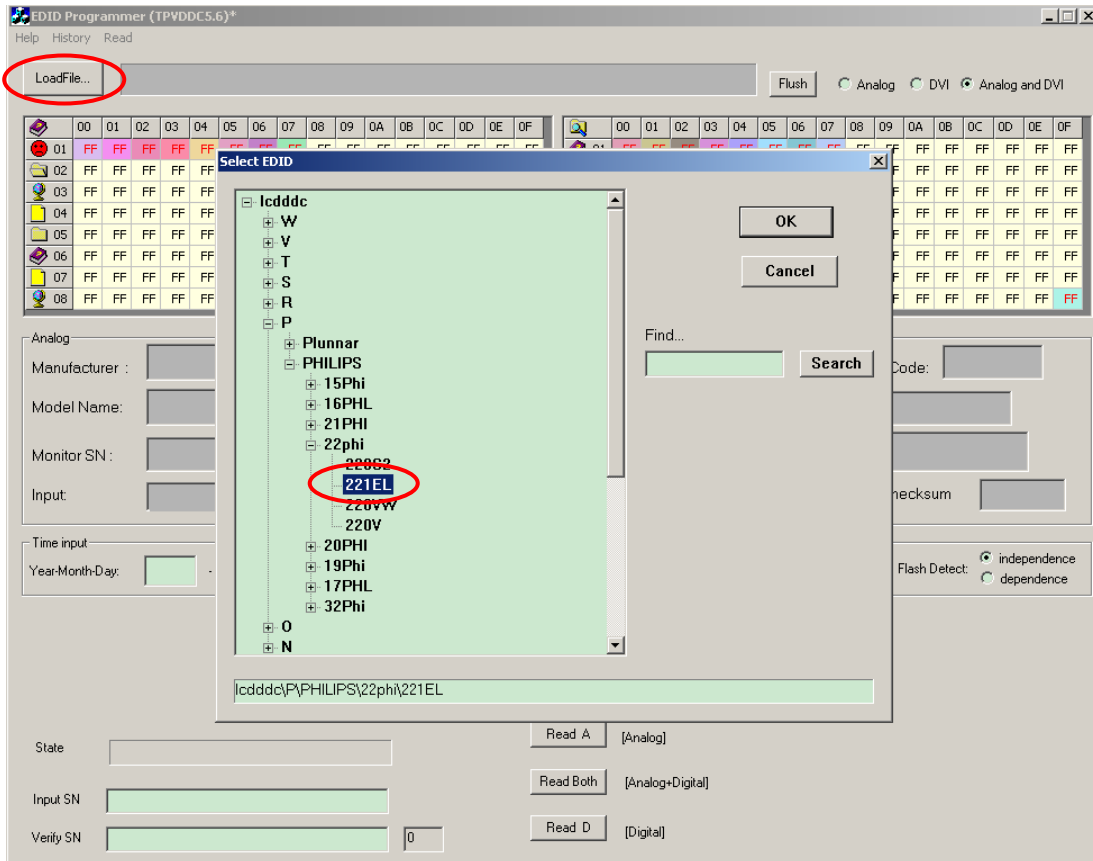

5. Click "OK", it will show the picture as follow:

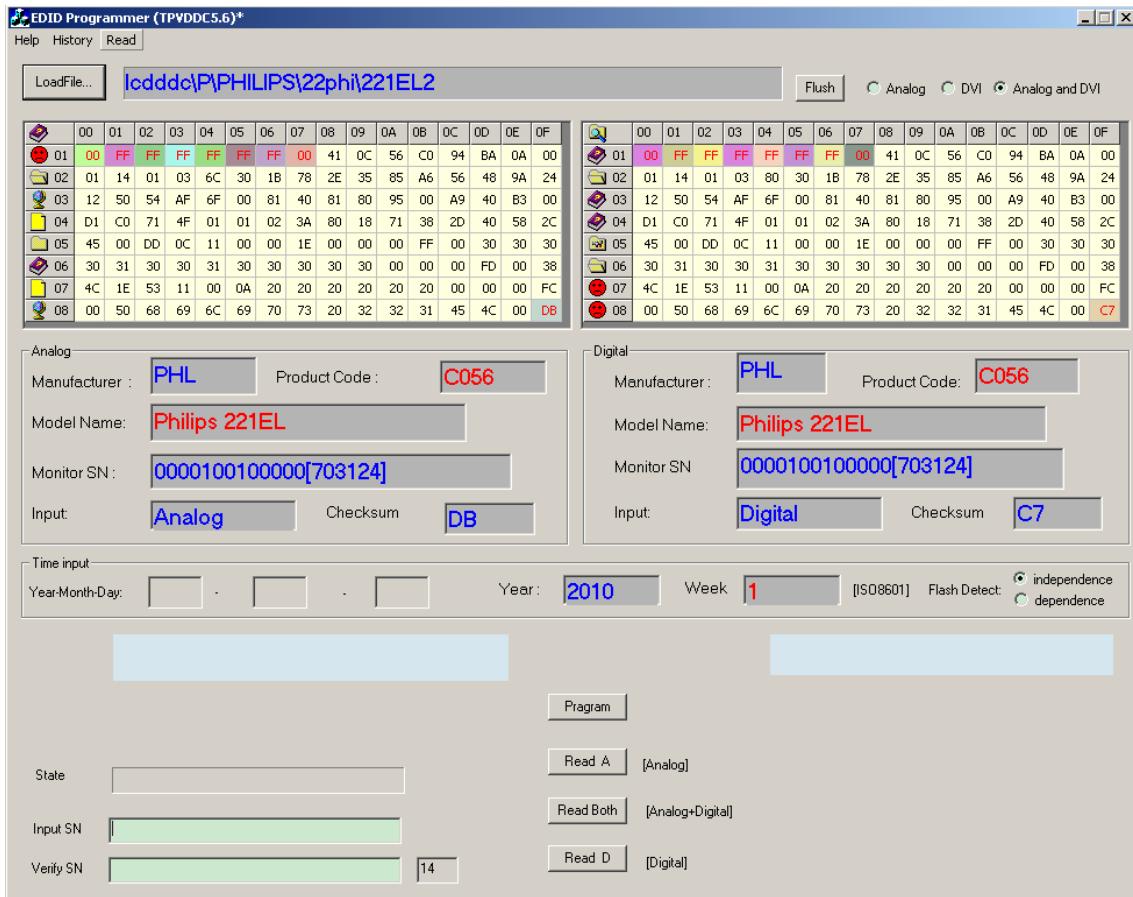

6. Key in the same 14 numbers in the Input SN and Verify SN.

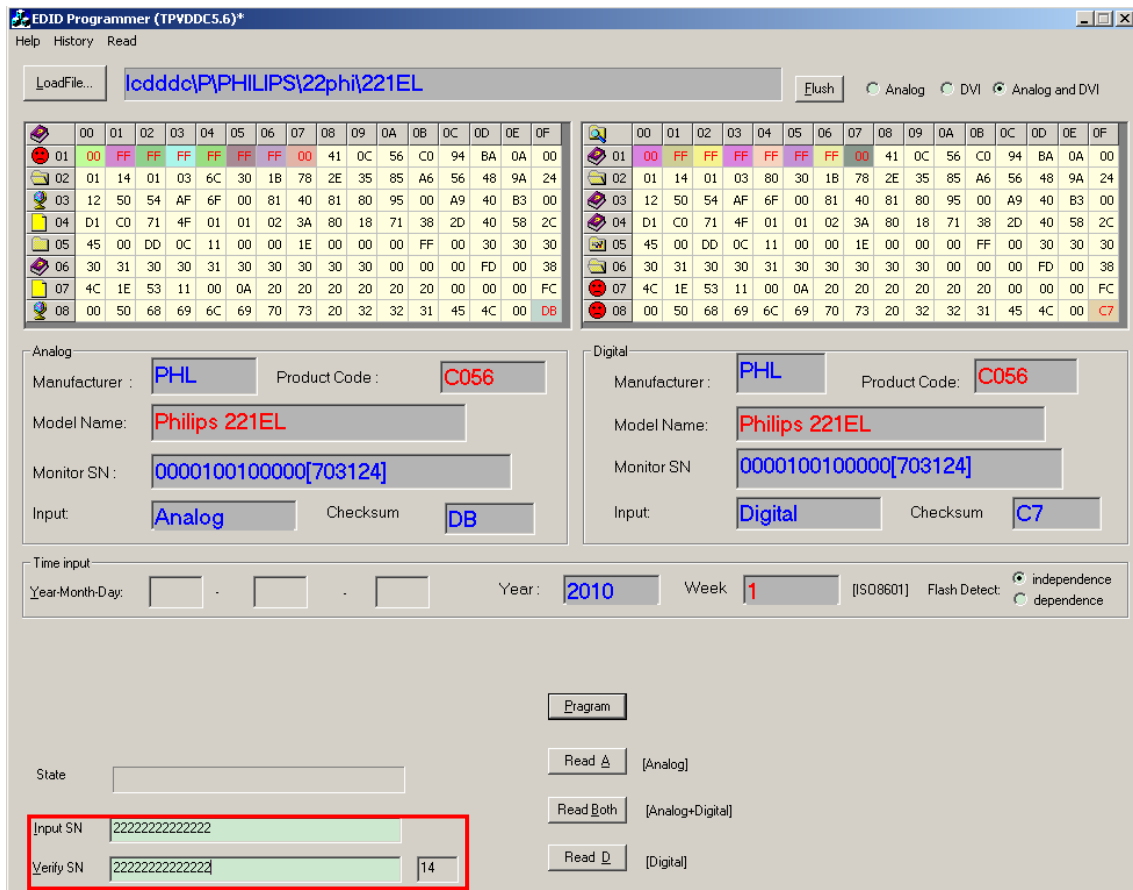

7. Click "Program", when the DDC Write complete, it will show the picture as follow:

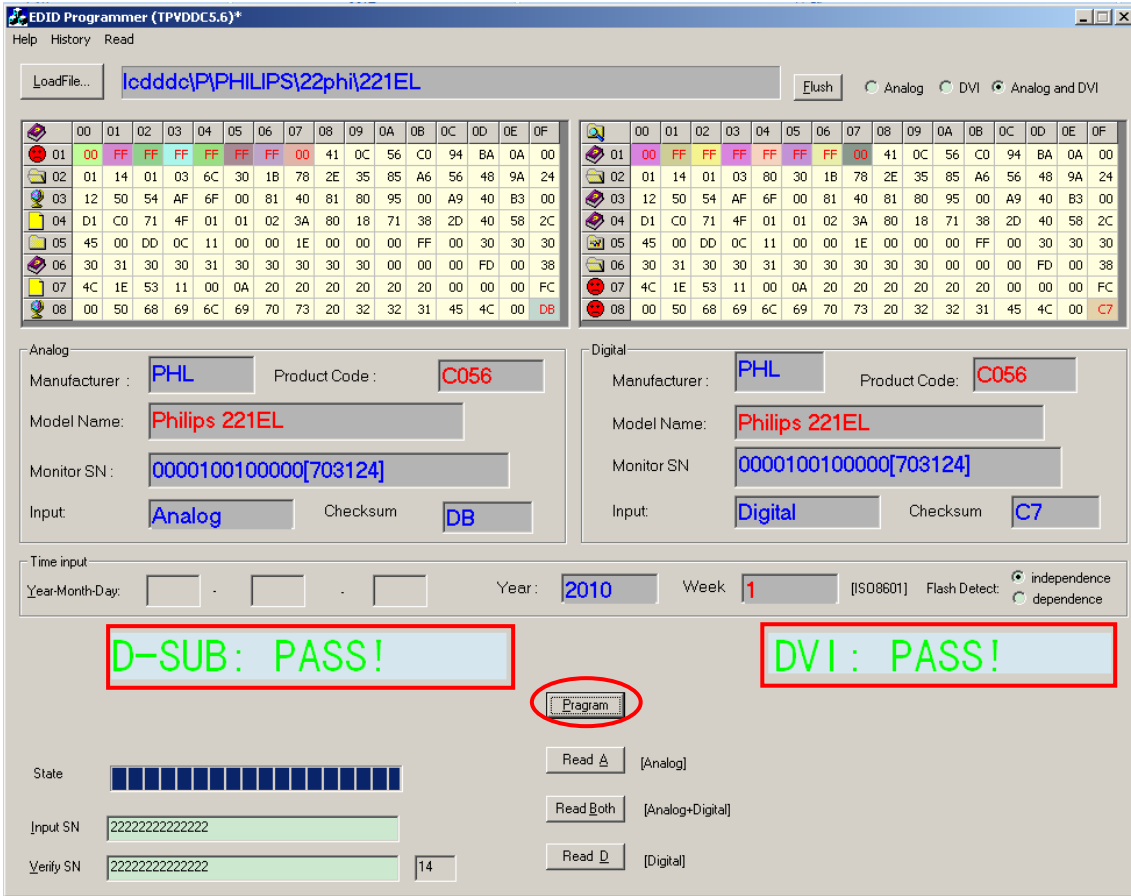

8. Click "ReadBoth", if the DDC Write is OK, it will show the picture as follow:

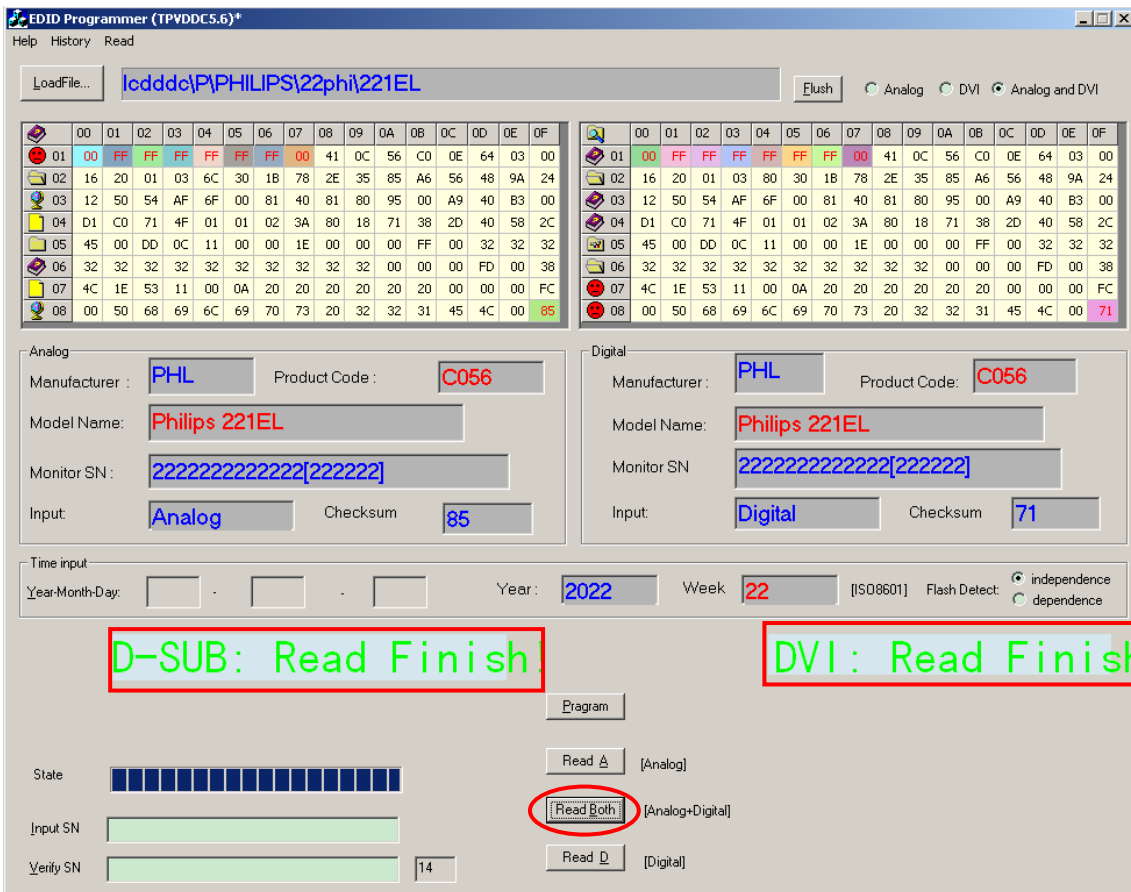

191E2 EDID

Analog

00 01 02 03 04 05 06 07 08 09 0A 0B 0C 0D 0E 0F

00| 00 FF FF FF FF FF FF 00 41 0C 4F C0 01 01 01 01
10| 04 14 01 03 6E 29 17 78 2A A8 15 A6 54 4B 9B 25
20| 13 50 54 BF EF 80 81 80 71 4F 01 01 01 01 01 01
30| 01 01 01 01 01 01 66 21 56 AA 51 00 1E 30 46 8F
40| 33 00 9A E6 10 00 00 1E 00 00 00 FF 00 30 30 30
50| 30 30 30 30 30 30 30 30 30 31 00 00 00 FC 00 50
60| 68 69 6C 69 70 73 20 31 39 31 45 0A 00 00 00 FD
70| 00 38 4C 1E 53 0E 00 0A 20 20 20 20 20 20 00 D1

EDID Structure Version/Revision: 01 03

<-Vendor/Product Identification: ->

ID Manufacturer Name: PHL
ID Product Code: C04F
ID Serial Number: No Use
Week of Manufacture: 4
Year of Manufacture: 2010

<-Basic Display Parameters/Features: ->

Video i/p definition: Analog
Max. H. Image Size: 41cm
Max. V. Image Size: 23cm
Display Gamma: 2.2

<-Color Characteristics: ->

Rx: 0.650 Gx: 0.295 Bx: 0.145 Wx: 0.313
Ry: 0.330 Gy: 0.605 By: 0.075 Wy: 0.329

<-Established Timings: ->

Established Timings 1: BF
720 x 400 @ 70Hz VGA, IBM
640 x 480 @ 60Hz VGA, IBM
640 x 480 @ 67Hz Apple, Mac II
640 x 480 @ 72Hz VESA

64 Meridian 2

640 x 480 @ 75Hz VESA

800 x 600 @ 56Hz VESA

800 x 600 @ 60Hz VESA

Established Timings 2: EF

800 x 600 @ 72Hz VESA

800 x 600 @ 75Hz VESA

832 x 624 @ 75Hz Apple, Mac II

1024 x 768 @ 60Hz VESA

1024 x 768 @ 70Hz VESA

1024 x 768 @ 75Hz VESA

1280 x 1024 @ 75Hz VESA

Established Timings 3:80

1152 x 870 @ 75Hz Apple, Mac II

<-Standard Timing Identification: ->

1280 x 1024 @ 60Hz

1152 x 864 @ 75Hz

<-Detailed Timing Descriptions: ->

FC (Monitor Name): Philips 191E

FD (Monitor Limits):

Min. V. rate: 56 Hz

Max. V. rate: 76 Hz

Min. H. rate: 30 KHz

Max. H. rate: 83 KHz

Max. P Clock: 140 MHz

FF (Monitor SN): 0000000000001

Detailed Timing: 1366x768 @ 60Hz

Extension Flag: 00

Block0 Checksum: D1

Digital

00 01 02 03 04 05 06 07 08 09 0A 0B 0C 0D 0E 0F

00| 00 FF FF FF FF FF FF 00 41 0C 4F C0 01 01 01 01
10| 04 14 01 03 80 29 17 78 2A A8 15 A6 54 4B 9B 25
20| 13 50 54 BF EF 80 81 80 71 4F 01 01 01 01 01 01
30| 01 01 01 01 01 01 66 21 56 AA 51 00 1E 30 46 8F
40| 33 00 9A E6 10 00 00 1E 00 00 00 FF 00 30 30 30
50| 30 30 30 30 30 30 30 30 30 31 00 00 00 FC 00 50
60| 68 69 6C 69 70 73 20 31 39 31 45 0A 00 00 00 FD
70| 00 38 4C 1E 53 11 00 0A 20 20 20 20 20 00 BC

EDID Structure Version/Revision: 01 03

<-Vendor/Product Identification: ->

ID Manufacturer Name: PHL
ID Product Code: C04F
ID Serial Number: No Use
Week of Manufacture: 4
Year of Manufacture: 2010

<-Basic Display Parameters/Features: ->

Video i/p definition: Digital
Max. H. Image Size: 41cm
Max. V. Image Size: 23cm
Display Gamma: 2.2

<-Color Characteristics: ->

Rx: 0.650 Gx: 0.295 Bx: 0.145 Wx: 0.313
Ry: 0.330 Gy: 0.605 By: 0.075 Wy: 0.329

<-Established Timings: ->

Established Timings 1: BF
720 x 400 @ 70Hz VGA, IBM
640 x 480 @ 60Hz VGA, IBM
640 x 480 @ 67Hz Apple, Mac II
640 x 480 @ 72Hz VESA
640 x 480 @ 75Hz VESA

66 Meridian 2

800 x 600 @ 56Hz VESA

800 x 600 @ 60Hz VESA

Established Timings 2: EF

800 x 600 @ 72Hz VESA

800 x 600 @ 75Hz VESA

832 x 624 @ 75Hz Apple, Mac II

1024 x 768 @ 60Hz VESA

1024 x 768 @ 70Hz VESA

1024 x 768 @ 75Hz VESA

1280 x 1024 @ 75Hz VESA

Established Timings 3:80

1152 x 870 @ 75Hz Apple, Mac II

<-Standard Timing Identification: ->

1280 x 1024 @ 60Hz

1152 x 864 @ 75Hz

<-Detailed Timing Descriptions: ->

FC (Monitor Name): Philips 191E

FD (Monitor Limits):

Min. V. rate: 56 Hz

Max. V. rate: 76 Hz

Min. H. rate: 30 KHz

Max. H. rate: 83 KHz

Max. P Clock: 170 MHz

FF (Monitor SN): 0000000000001

Detailed Timing: 1366x768 @ 60Hz

Extension Flag: 00

Block0 Checksum: BC

191EL2 EDID

Analog

00 01 02 03 04 05 06 07 08 09 0A 0B 0C 0D 0E 0F

00| 00 FF FF FF FF FF FF 00 41 0C 50 C0 01 01 01 01
10| 09 14 01 03 6E 29 17 78 2A A8 15 A6 54 4B 9B 25
20| 13 50 54 BF EF 80 81 80 71 4F 01 01 01 01 01
30| 01 01 01 01 01 01 66 21 56 AA 51 00 1E 30 46 8F
40| 33 00 9A E6 10 00 00 1E 00 00 00 FF 00 30 30 30
50| 30 30 30 30 30 30 30 30 30 31 00 00 00 FC 00 50
60| 68 69 6C 69 70 73 20 31 39 31 45 4C 00 00 00 FD
70| 00 38 4C 1E 53 0E 00 0A 20 20 20 20 20 20 00 89

EDID Structure Version/Revision: 01 03

<-Vendor/Product Identification: ->

ID Manufacturer Name: PHL
ID Product Code: C050
ID Serial Number: No Use
Week of Manufacture: 9
Year of Manufacture: 2010

<-Basic Display Parameters/Features: ->

Video i/p definition: Analog
Max. H. Image Size: 41cm
Max. V. Image Size: 23cm
Display Gamma: 2.2

<-Color Characteristics: ->

Rx: 0.650 Gx: 0.295 Bx: 0.145 Wx: 0.313
Ry: 0.330 Gy: 0.605 By: 0.075 Wy: 0.329

<-Established Timings: ->

Established Timings 1: BF
720 x 400 @ 70Hz VGA, IBM
640 x 480 @ 60Hz VGA, IBM
640 x 480 @ 67Hz Apple, Mac II
640 x 480 @ 72Hz VESA

640 x 480 @ 75Hz VESA

800 x 600 @ 56Hz VESA

800 x 600 @ 60Hz VESA

Established Timings 2: EF

800 x 600 @ 72Hz VESA

800 x 600 @ 75Hz VESA

832 x 624 @ 75Hz Apple, Mac II

1024 x 768 @ 60Hz VESA

1024 x 768 @ 70Hz VESA

1024 x 768 @ 75Hz VESA

1280 x 1024 @ 75Hz VESA

Established Timings 3:80

1152 x 870 @ 75Hz Apple, Mac II

<-Standard Timing Identification: ->

1280 x 1024 @ 60Hz

1152 x 864 @ 75Hz

<-Detailed Timing Descriptions: ->

FC (Monitor Name): Philips 191EL

FD (Monitor Limits):

Min. V. rate: 56 Hz

Max. V. rate: 76 Hz

Min. H. rate: 30 KHz

Max. H. rate: 83 KHz

Max. P Clock: 140 MHz

FF (Monitor SN): 0000000000001

Detailed Timing: 1366x768 @ 60Hz

Extension Flag: 00

Block0 Checksum: 89

Digital

00 01 02 03 04 05 06 07 08 09 0A 0B 0C 0D 0E 0F

00| 00 FF FF FF FF FF FF 00 41 0C 50 C0 01 01 01 01
10| 09 14 01 03 80 29 17 78 2A A8 15 A6 54 4B 9B 25
20| 13 50 54 BF EF 80 81 80 71 4F 01 01 01 01 01
30| 01 01 01 01 01 01 66 21 56 AA 51 00 1E 30 46 8F
40| 33 00 9A E6 10 00 00 1E 00 00 00 FF 00 30 30 30
50| 30 30 30 30 30 30 30 30 30 31 00 00 00 FC 00 50
60| 68 69 6C 69 70 73 20 31 39 31 45 4C 00 00 00 FD
70| 00 38 4C 1E 53 11 00 0A 20 20 20 20 20 00 74

EDID Structure Version/Revision: 01 03

<-Vendor/Product Identification: ->

ID Manufacturer Name: PHL
ID Product Code: C050
ID Serial Number: No Use
Week of Manufacture: 9
Year of Manufacture: 2010

<-Basic Display Parameters/Features: ->

Video i/p definition: Digital
Max. H. Image Size: 41cm
Max. V. Image Size: 23cm
Display Gamma: 2.2

<-Color Characteristics: ->

Rx: 0.650 Gx: 0.295 Bx: 0.145 Wx: 0.313
Ry: 0.330 Gy: 0.605 By: 0.075 Wy: 0.329

<-Established Timings: ->

Established Timings 1: BF
720 x 400 @ 70Hz VGA, IBM
640 x 480 @ 60Hz VGA, IBM
640 x 480 @ 67Hz Apple, Mac II
640 x 480 @ 72Hz VESA
640 x 480 @ 75Hz VESA

70 Meridian 2

800 x 600 @ 56Hz VESA

800 x 600 @ 60Hz VESA

Established Timings 2: EF

800 x 600 @ 72Hz VESA

800 x 600 @ 75Hz VESA

832 x 624 @ 75Hz Apple, Mac II

1024 x 768 @ 60Hz VESA

1024 x 768 @ 70Hz VESA

1024 x 768 @ 75Hz VESA

1280 x 1024 @ 75Hz VESA

Established Timings 3:80

1152 x 870 @ 75Hz Apple, Mac II

<-Standard Timing Identification: ->

1280 x 1024 @ 60Hz

1152 x 864 @ 75Hz

<-Detailed Timing Descriptions: ->

FC (Monitor Name): Philips 191EL

FD (Monitor Limits):

Min. V. rate: 56 Hz

Max. V. rate: 76 Hz

Min. H. rate: 30 KHz

Max. H. rate: 83 KHz

Max. P Clock: 170 MHz

FF (Monitor SN): 0000000000001

Detailed Timing: 1366x768 @ 60Hz

Extension Flag: 00

Block0 Checksum: 74

14. White Balance, Luminance Adjustment

1. **Apparatuses and program:** analyzer CA-210, PC, tool, FGA adjustment program (PHILIPS 191E2.DDCI, 191EL2.DDCI), Pattern generator.

2. Equipment installation:

- Connect analyzer CA-210 to PC by USB connector, install drive program CA-SDK Ver4.00 for CA-210 and restart PC after finish installing
- Install Port95NT drive program, set PC printer connector mode as ECP mode and reset PC after finish installing.
- Connect tool as follow:

Note: It's not necessary to connect Port2.

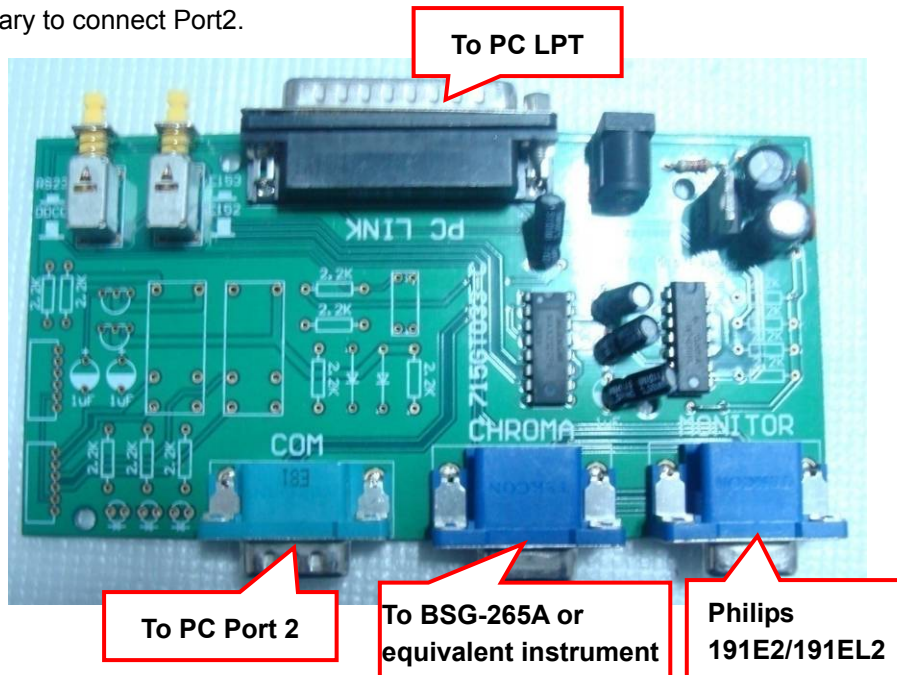

3. Adjustment

Preparation before adjustment:

- Monitor should be warmed up for more than half an hour.
- Make sure that the tools are connected right and drive programs have been installed OK.

4. Adjustment process:

- Press the power of CA-210, shut off the lens, press 0-Cal and open the lens after analyzer reset.
- Open white balance adjustment program, select the right parameter according with the program and click OK.
- Make sure that the lens of CA-210 aims at the center of the screen, then click START to adjust.
- After finish adjusting, the adjustment program displays pass, and the START button changes for NEXT, which means that you can adjust another monitor.

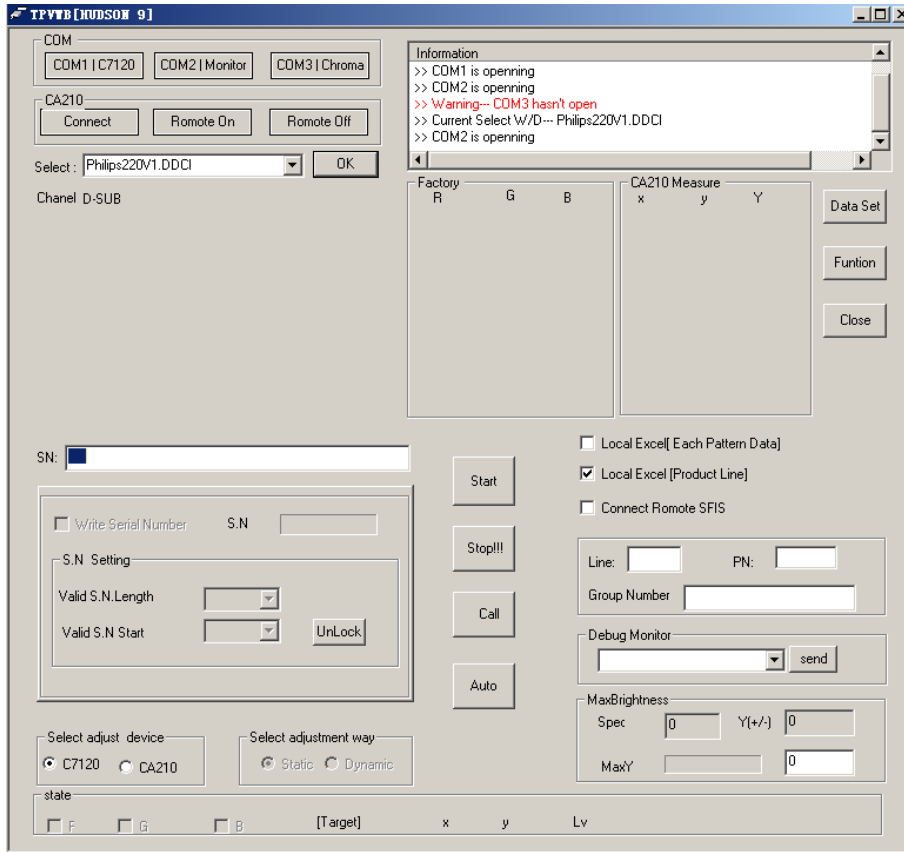

5. Color Temp confirmation

Connect the signal to the monitor, the monitor displays white-picture, use CA-210 to measure the Color Temp of the screen center and select the OSD to make sure whether the Color Temps accord with the SPEC.

6. How to enter into the factory mode:

Press the MENU and DOWN buttons at the same time, and then DC ON/OFF, the picture will appear on the top left corner. Choose "Input" item, and then choose "Factory", you will enter into the factory mode.

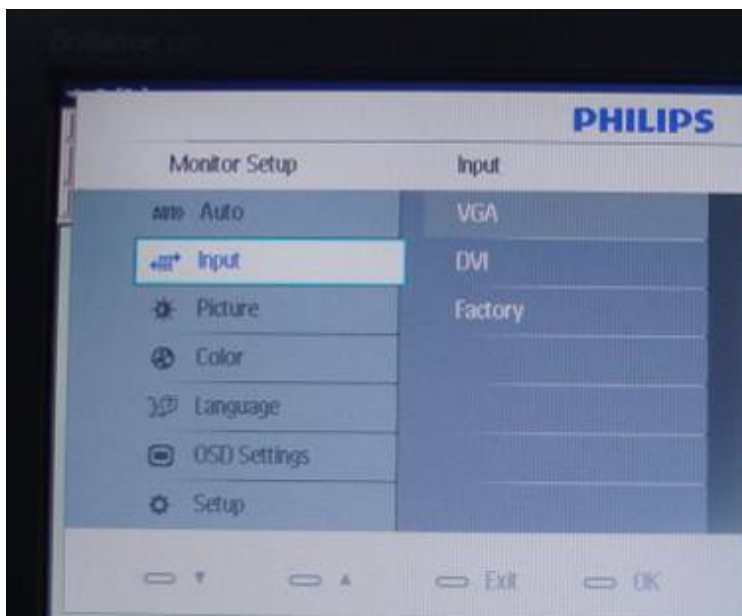

15. Monitor Exploded View

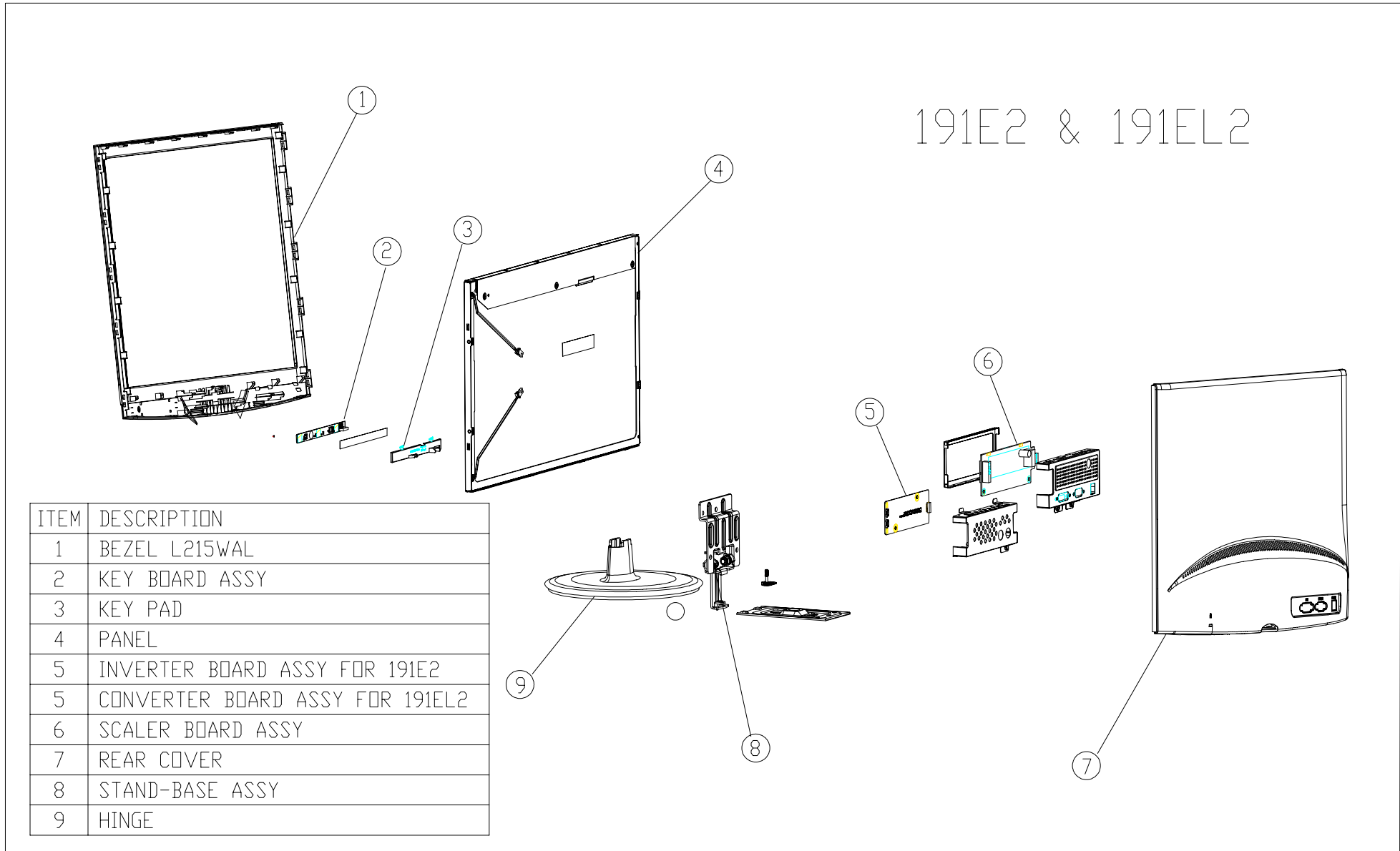

16. Recommended & Spare Parts List

Note: The parts information listed below are for reference only, and are subject to change without notice. Please go to <http://cs.tpv.com.cn/hello1.asp> for the latest information

Recommended Parts List for 191E2SB/00

Item	Location	PCM Codes	Description	Remark
1	FQ106	Q34G7110AFLB8B0130	BEZEL L185WA-TU8-TUS8	
2	FQ004	KEPC9QPJ	KEY BOARD ASSY	
3	FQ405	A33G0797AFL 1L0100	KEY	
4	E750	750GLG185W1F11M0PH	PANEL LM185WH1-TLF1 KR LGD	
4	E750	750GLG185W1F11N000	PANEL LM185WH1-TLF1 KR LGD	
5	FQ009	INPC9C22AAA5	INVERTER BOARD ASSY	
6	FQ002	756GQ9CB PH131 00	SCALER BOARD ASSY(CBPCAM6PHQ1)	
7	FQ105	Q34G7111AFLA5B0100	REAR COVER	
8	FQ103	A34G1919AFL 1B0130	STAND-BASE ASSEY	
9	FQ110	Q37G0193021	HINGE	
	FQ302	089G 728HAA 2G	SIGNAL CABLE	
	FQ301	089G404A15N IS	AC POWER CORD 1500MM Europe Reg.	
	E09501	095G8018 3LJ08	LVDS CABLE 30P-30P 320MM	
	FQ205	Q44G8054101	EPS	
	FQ205	Q44G8054201	EPS	
	FQ202	Q44G8054813 1A	CARTON 18.5 LCD PHILIPS	
	FQ203	Q45G 88609206 N	EPE BAG	
	U402	100GPMG8000NT1	MCU ASSY(056G1133129)	
	X401	093G 22 53 J	14.31818MHZ/32PF/49US	
	U401	056G 562337	IC TSUMU58NWHL-LF PQFP-100	
	U704	056G 563113	IC G1117-18T63Uf 1A/1.8V SOT-223	
	U705	056G 563215	IC DC/DC MP1584EN SOIC8E	
	U702	056G 563512	IC G1117-33T43UF TO-252	
	U103	056G 662502	C ESD AZC199-04S SOT23-6L	
	U104	056G 662502	C ESD AZC199-04S SOT23-6L	
	U105	056G 662502	C ESD AZC199-04S SOT23-6L	
	U106	056G 662502	C ESD AZC199-04S SOT23-6L	
	U107	056G 662502	C ESD AZC199-04S SOT23-6L	
	FQ010	ADPCA1236YQAX	ADAPTER BOARD ASSY	
	IC902	056G 139 3A	IC PC123Y22FZ0F	
	T901	S80GL19P512V	Transformer ASSY	

	IC901	056G 379530	IC LD7750GS 65KHZ SOP-8	
	IC903	056G 158 12	KIA431A-AT/P TO-92	
	F901	084G 56 3 B	FUSE 3.15A 250V	
	IC801	056G 608 12	IC ta9687GN-A-0-TR SOP-16	
	U001	056G 669 10	IC CG7246AM QFN-16(COL)	

Recommended Parts List for 191EL2SB/00

Item	Location	PCM Codes	Description	Remark
1	FQ106	Q34G7110AFLA9B0102	BEZEL	CPT 6
1	FQ106	Q34G7110AFLA8B0101	BEZEL	SEC/ AUO VDT0
1	FQ106	Q34G7110AFLA8B0102	BEZEL	AUO VD/ CPT 0
2	FQ405	A33G0797AFL 1L0100	KEY	
3	FQ004	KEPC9QPJ	KEY BOARD ASSY	
4	E750	750GBC185WA413M0PH	LCD CLAA185WA04 6GL FZ CPT	
4	E750	750GBC185WA413N000	LCD CLAA185WA04 6GL FZ CPT	
4	E750	750GBC185WA423M0PH	LCD CLAA185WA04 6HM FZ CPT	
4	E750	750GBC185WA423N000	LCD CLAA185WA04 6HM FZ CPT	
4	E750	750GBU185X1D1HM0PH	LCD M185XW01 VDT0 WH AUO	
4	E750	750GBU185X1D1HN000	LCD M185XW01 VDT0 WH AUO	
4	E750	750GBS185AT4A4N000	LCD LTM185AT04 701(010) DS SEC	
4	E750	750GBS185AT4A4M0PH	LCD LTM185AT04 701(010) DS SEC	
4	E750	750GBU185X1D04N000	LCD M185XW01 VD00 SH AUO	
4	E750	750GBU185X1D07M0PH	LCD M185XW01 VD00 WJ AUO	
4	E750	750GBU185X1D07N000	LCD M185XW01 VD00 WJ AUO	
4	E750	750GBU185X1DA4N000	LCD M185XW01 VD0A SH AUO	
4	E750	750GBU185X1DA7M0PH	LCD M185XW01 VD0A WJ AUO	
4	E750	750GBU185X1DA7N000	LCD M185XW01 VD0A WJ AUO	
4	E750	750GLC185WA413M0PH	PANEL CLAA185WA04 000 FZ CPT	
4	E750	750GLC185WA413N000	PANEL CLAA185WA04 000 FZ CPT	
4	E750	750GLC185WA423M0PH	PANEL CLAA185WA04 011 FZ CPT	
4	E750	750GLC185WA423N000	PANEL CLAA185WA04 011 FZ CPT	
5	FQ011	LNPCA4201SQCL	CONVERTER BOARD ASSY	CPT 6/ SEC
5	FQ004	LNPCA4201AQCUC	CONVERTER BOARD ASSY	AUO VDT0
5	FQ011	LNPCAA461SQC5	CONVERTER BOARD ASSY	AUO VD
5	FQ011	LNPCA8451CQAU	CONVERTER BOARD ASSY	CPT 0
6	FQ002	756GQACB PH205 00	SCLAER BOARD ASSY(CBPCAANPHQ2)	CPT 6
6	FQ002	756GQACB PH097 00	SCALER BOARD ASSY(CBPCAANPHQ4)	AUO VDT0

76 Meridian 2

6	FQ002	756GQACB PH095 00	SCALER BOARD ASSY(CBPCAANPHQ2)	SEC
6	FQ002	756GQACB PH071 00	SCLAER BOARD ASSY(CBPCAM6PHQ1)	AUO VD
6	FQ002	756GQACB PH015 00	SCLAER BOARD ASSY(CBPCAM6PHQ1)	CPT 0
7	FQ105	Q34G7111AFLAGB0100	REAR COVER	CPT 6
7	FQ105	Q34G7111AFLAFB0100	REAR COVER	AUO VDT0
7	FQ105	Q34G7111AFLADB0100	REAR COVER	SEC
7	FQ105	Q34G7111AFLA3B0100	REAR COVER	AUO VD
7	FQ105	Q34G7111AFLA4B0100	REAR COVER	CPT 0
8	FQ103	A34G1919AFL 1B0130	STAND-BASE ASSY	
9	M037	Q37G0193021	HINGE 18.5	
	E08902	089G 728HAA 2G	SIGNAL CABLE	
	E08901	089G404A15N IS	AC POWER CORD 1500	
	E09501	095G8014 7D 28	HARNESS 7P-6P 240mm FQE102851I	
	E09502	095G801830D195	HARNESS 30P-2*15P 160mm FQE102853I	
	E09503	095G8022 6X 3	HARNESS 6P-6P 560mm LCDXXTF0881	CPT 6
	E09503	095G8022 6X 3	HARNESS 6P-6P 560mm LCDXXTF0881	AUO VDT0
	E09503	095G8022 6D521	HARNESS 6P-6P 520mm	SEC
	E09501	095G8018 3LJ08	HARNESS 30P-30P 240	AUO VD/ CPT 0
	E09502	095G8014 7D942	HARNESS 7P-6P 300mm FQE100033I	AUO VD/ CPT 0
	E09503	095G802210D508	HARNESS 10P-10P 330MM	AUO VD/ CPT 0
	E09504	095G8022 6X513	HARNESS 6P-6P(A1253HA HR) 85mm	AUO VD/ CPT 0
	FQ202	Q44G8054813 3A	CARTON 18.5 LCD PHILIPS	
	FQ212	Q45G 88609206 N	EPE BAG	
	FQ124	A15G1522101	MAIN_FRAME FOR MB 135X60	
	FQ205	803GQA44083	L185WA-TU8-TUS8-EPS-ASSY	
	FQ003	ADPCA1236YQAX	POWER BOARD ASSY	
	IC902	056G 139 3A	PC123Y22FZOF SHARP	
	T901	S80GL19P512V	TRANSFORMER ASSY	
	IC901	056G 379530	AC/DC CONVERTER LD7750GS SOP-8	
	IC903	056G 158 12	Shunt Regulator KIA431A-AT/P TO-92	
	F901	084G 56 3 B	FUSE 3.15A 250V	
	U401	056G 562360	Scaler TSUMU58NWHL5-LF PQFP-100	
	U401	056G 562337	IC TSUMU58NWHL-LF PQFP-100	AUO VD
	U402	100GPMC8002NT1	MCU ASSY(056G2233 3)	CPT 6
	U402	100GPMA8004NT1	MCU ASSY(056G2233 3)	AUO VDT0
	U402	100GPMS8002NT1	MCU ASSY(056G2233 3)	SEC
	U402	100GPMA8002NT1	MCU ASSY(056G1133129)	AUO VD

	U402	100GPMC8000NT1	MCU ASSY(056G1133129)	CPT 0
	X401	093G 22 53 J	CRYSTAL 14.31818MHZ/32PF49US	
	U401	056G 562360	SCALER TSUMU58NWHL5-LF PQFP-100	
	U401	056G 562337	IC TSUMU58NWHL-LF PQFP-100	AUO VD/ CPT 0
	U703	056G 563113	IC G1117-18T63Uf 1A/1.8V SOT-223	
	U705	056G 563215	IC DC/DC MP1584EN SOIC8E	
	U701	056G 563512	IC G1117-33T43UF 1A/3.3V TO-252	
	U105	056G 662502	IC ESD AZC199-04S.R7G SOT23-6L	
	U106	056G 662502	IC ESD AZC199-04S.R7G SOT23-6L	
	U107	056G 662502	IC ESD AZC199-04S.R7G SOT23-6L	
	U102	056G 662502	EEPROM FM24C02A-SO-T-G 2K SOP-8	
	U101	056G 662502	EEPROM FM24C02A-SO-T-G 2K SOP-8	
	IC801	056G 700 15	LED DRIVER TA9690LN-A1-0-TR QFN-24	
	IC801	056G 379185	AC/DC CONVERTER TA9690GN-A1-0-TR SOP-24	AUO VD/ CPT 0
	U001	056G 669 10	TOUCH KEY CG7246AMT QFN-16(COL)	

Spare Parts List for 191EL2SB/93

Location	PCM Codes	Description
FQ302	089G 728HAA 2G	SIGNAL CABLE
FQ301	089G414A15N IS	AC POWER CORD 1500MM CHINA Reg.
E09501	095G8018 3LJ08	LVDS CABLE 30P-30P 320MM
E09501	095G8018 3XJ08	LVDS CABLE 30P-30P 320MM
E750	750GLU185X1614N000	PANEL M185XW01 V600 SH AUO
E750	750GLU185X1624N000	PANEL M185XW01 V60A SH AUO
E750	750GMU185X1614M0PH	PANEL M185XW01 V600 SH AUO
E750	750GMU185X1624M0PH	PANEL M185XW01 V60A SH AUO
FQ405	A33G0797AFL 1L0100	KEY
FQ103	A34G1919AFL 1B0130	STAND-BASE ASSEY
FQ106	Q34G7110AFLA8B0130	BEZEL
FQ105	Q34G7111AFLA3B0100	REAR COVER
FQ110	Q37G0193021	HINGE
FQ201	Q40G 18E81314A	RATING LABEL
FQ201	Q40G 18E81315A	RATING LABEL
FQ205	705GQACS 34017	EPS ASSY
FQ202	Q44G8054813 4A	CARTON
FQ203	Q45G 88609206 N	EPE BAG
FQ204	Q70G19C1813 6A	CD MANUAL CD 191EL2 M2191E1T

E09504	S95G176T10512	LVDS ASSY
FQ010	ADPCA1236YQAX	ADAPTER BOARD ASSY
IC902	056G 139 3A	IC PC123Y22FZ0F
NR901	061G 58005 W	RST NTCR 5 OHM 3A THINKING
R904	061G152M47852T	RST MOFR 0.47 OHM +-5% 2WS
C903	063G107M47410M	CAP X2 0.47UF 20% 275VAC
C909	065G 1K103 2E6921	CAP CER 10NF K 1KV Y5U
C900	065G306M1022B2	1000pf 400vac/250vac y1
C919	067G 515681 4L	EC 680UF 20% 25V RZW 8*20
C918	067G 515681 4L	EC 680UF 20% 25V RZW 8*20
C919	067G215C5614NV	EC 560UF 20% 25V KZM 8*20
C918	067G215C5614NV	EC 560UF 20% 25V KZM 8*20
C919	067G215C5614RV	EC 560UF 20% 25V ZLH 8*20
C918	067G215C5614RV	EC 560UF 20% 25V ZLH 8*20
C927	067G215V101 4R	LOW E.S.R 100uF M 25V
C907	067G515Z82015L	EC 82UF 20% 450V RXQ 18*31.5
C907	067G515Z82015N	EC 82UF 20% 450V KXG 18*30
D902	071G 55 30	FERRITE BEAD 4.0*2*3
D903	071G 55 30	FERRITE BEAD 4.0*2*3
L902	073G 174514 H	LINE FILTER 14mH MIN LCL-11402 HA
L902	073G 174514 S	LINE FILTER 14mH MIN
L901	073G 174515 H	LINE FILTER 0.45mH MIN LCL-11006 HA
L901	073G 174515 S	LINE FILTER 0.45mH MIN
L903	073G 253902 H	IND CHOKE 0.8uH MIN DADO
L903	073G 253902 S	IND CHOKE 0.8uH MIN TAIC
T901	080GL19P512 H	POWER XFMR 700uH 5% BCK-11002-HA
T901	080GL19P512 S	POWER XFMR 700uH 5% BCK-RM10-26209
LED1	081G 2 3 1P	LED GPG2603T/R006-35A GUANGPU
E08906	089G 171535 G	DC CABLE 1000MM
E08906	089G 171536 C	DC CABLE 1200MM
E08906	089G 171536 G	DC CABLE 1200MM
E08906	089G 171536 H	DC CABLE 1200MM
BD901	093G 50460514	BRIDGE KBP306G 3A/800V TSC
D903	093G 52 1552T	DIODE 1N4007-E3/73 1A/1000V DO-41
D902	093G 5212T52T	DIODE 1N4007 DO-41
D903	093G 5212T52T	DIODE 1N4007 DO-41
T901	S80GL19P512V	Transformer ASSY
D906	093G 60226	STPS20H100CT
D906	093G 60228	MBR20100CT 20A 100VGI

D906	093G 605AP	Diode MBR20100CT
HS1	Q90G0201 1	HEAT SINK
Q901	057G 667 21	STP10NK70ZFP
Q901	057G 667924	MOSFET SMK0965F
HS1	Q90G0200 1	HEAT SINK
CN901	087G 50112A CJ	AC SOCKET
CN901	087G 50112A DL	AC SOCKET 3PIN
IC901	056G 379530	IC LD7750GS 65KHZ SOP-8
R912	061G0603102 JF	RST CHIPR 1K OHM +-5% 1/10W FENGHUA
R911	061G0603202 JT	RST CHIPR 2KOHM 1/10W TZAI YUAN
R918	061G0603203 JT	RST CHIP 20K 1/10W 5% TZAI YUAN
R940	061G0603221 JF	ST CHIPR 220 OHM +-5% 1/10W FENGHUA
R919	061G06034532FF	RST CHIPR 45.3KOHM +-1% 1/10W FENGHUA
R905	061G08051002FF	RST CHIPR 10KOHM +-1% 1/8W FENGHUA
R905	061G08051002FY	RST CHIPR 10KOHM +-1% 1/8W YAGEO
R903	061G08051004FF	RST CHIPR 1 MOHM +-1% 1/8W FENGHUA
R903	061G08051004FT	RST CHIP R 1 MOHM +-1% 1/8W
R942	061G0805101 JY	RST CHIPR 100OHM +- 5% 1/8W YEGAO
R910	061G0805104 JT	RST CHIPR 100KOHM +- 5% 1/8W TZAI YUAN
R916	061G08051152FT	RST CHIPR 11.5KOHM +- 1% 1/8W TZAI YUAN
R941	061G0805159 JT	RST CHIP 1R5 1/8W 5%
R922	061G0805471 JT	RST CHIPR 470OHM +-5% 1/8W TZAI YUAN
JR901	061G1206000 7	RST CHIP MAX 0R05 1/4W
R908	061G1206101 JT	RST CHIPR 100 OHM +-5% 1/4W TZAI YUAN
R914	061G1206101 JT	RST CHIPR 100 OHM +-5% 1/4W TZAI YUAN
R906	061G1206103 JT	RST CHIPR 10KOHM +-5% 1/4W TZAI YUAN
R934	061G1206103 JT	RST CHIPR 10KOHM +-5% 1/4W TZAI YUAN
R902	061G1206105 JF	RST CHIPR 1 MOHM +-5% 1/4W FENGHUA
R901	061G1206105 JF	RST CHIPR 1 MOHM +-5% 1/4W FENGHUA
R907	061G1206564 JF	RST CHIPR 560KOHM +-5% 1/4W FENGHUA
R937	061G1206564 JF	RST CHIPR 560KOHM +-5% 1/4W FENGHUA
R938	061G1206564 JF	RST CHIPR 560KOHM +-5% 1/4W FENGHUA
C930	065G060310332K Y	CAP CHIP 0603 10N 50V X7R +/-10%
C915	065G060347332K F	CAP CHIP 0603 47NF K 50V X7R
C915	065G060347332K M	NDS-Assign MLCC 0603 CAP 0.047uF 50V X7R
C931	065G080510131J A	CAP CHIP 0805 100pF J 50V NPO
C931	065G080510131J F	CAP CHIP 0805 100PF J 50V NPO
C931	065G080510131J Y	CAP CHIP 0805 100PF J 50V NPO
C910	065G080510432K 3	CAP CHIP 0805 100N 50V X7R +/-10%

C901	065G080510522K 3	CAP CHIP 0805 1U 25V X7R +/-10%
C920	065G080510522K 3	CAP CHIP 0805 1U 25V X7R +/-10%
C911	065G120622272K Y	CAP CHIP 1206 2200PF K 500V X7R
C908	065G120622272K Y	CAP CHIP 1206 2200PF K 500V X7R
D908	093G 64S522SEM	LL4148
CN901	006G 31500	EYELET
A	006G 31501	EYELET
GND	006G 31501	EYELET
12V	006G 31501	EYELET
NR901	006G 31502	1.5MM RIVET
L902	006G 31502	1.5MM RIVET
L901	006G 31502	1.5MM RIVET
C907	006G 31502	1.5MM RIVET
C903	006G 31502	1.5MM RIVET
IC903	056G 158 12	KIA431A-AT/P TO-92
R947	061G 60210052T XZ	RST CFR 10 OHM +-5% 1/6W XIANZHENG
C925	065G 2K152 2T6921	CAP CER 1500pF K 2KV Y5P
C929	067G 2154707NT	KY50VB47M-TP5 6.3*11
FB901	071G 55908	FERRITE CORE 60R W5 RH 2.5X3X1.0
F901	084G 56 3 B	FUSE 3.15A 250V
FQ002	756GQ9CB PH132 00	SCALER BOARD ASSY(CBPCAM6PHQ1)
U402	100GPMA8000NT1	PHILIPS 191EL2
C718	067G204V181 3K	CS CAP 180uF 16V 8*8 mm
C716	067G204V471 2K	CS CAP 470uF 10V 8*8 mm
FB701	071G 55 26 S	FERRITE CORE
CN701	088G 304 11 C	DC POWER JACK 3P 2.5mm
CN101	088G 35315FVDL	D-SUB CONN 15P FEMALE V/T WITH SCREW
CN102	088G 35424F VC	DVI CONN 24P V/T WITH SCREW
X401	093G 22 53 J	14.31818MHZ/32PF/49US
CN402	033G8032 4F HR	CONNECTOR
CN401	033G8032 7F HR	CONNECTOR
CN702	033G803210F HR	CONNECTOR
U401	056G 562337	IC TSUMU58NWHL-LF PQFP-100
U704	056G 563113	IC G1117-18T63Uf 1A/1.8V SOT-223
U705	056G 563215	IC DC/DC MP1584EN SOIC8E
U702	056G 563512	IC G1117-33T43UF TO-252
U103	056G 662502	C ESD AZC199-04S SOT23-6L
U104	056G 662502	C ESD AZC199-04S SOT23-6L
U105	056G 662502	C ESD AZC199-04S SOT23-6L

U106	056G 662502	C ESD AZC199-04S SOT23-6L
U107	056G 662502	C ESD AZC199-04S SOT23-6L
U101	056G1133 34	M24C02-WMN6TP
U102	056G1133 34	M24C02-WMN6TP
U402	056G1133129	IC EN25F20-100GCP 2Mb SOP-8
U101	056G1133918	IC AT24C02BN-SH-T 8-SOIC
U102	056G1133918	IC AT24C02BN-SH-T 8-SOIC
Q402	057G 417517	Tra LMBT3906LT1G -200mA/-40V SOT-23 LRC
Q403	057G 417517	Tra LMBT3906LT1G -200mA/-40V SOT-23 LRC
Q302	057G 417518	TRA LMBT3904LT1G 200mA/40V SOT-23 LRC
Q401	057G 417518	TRA LMBT3904LT1G 200mA/40V SOT-23 LRC
Q701	057G 417518	TRA LMBT3904LT1G 200mA/40V SOT-23 LRC
Q301	057G 763 1	A03401 SOT23 BY AOS(A1)
R414	061G0402000 JY	RST CHIPR 0 OHM +-5% 1/16W YAGEO
R423	061G0402000 JY	RST CHIPR 0 OHM +-5% 1/16W YAGEO
R105	061G0402100 JY	RST CHIPR 10 OHM +-5% 1/16W YAGEO
R111	061G0402100 JY	RST CHIPR 10 OHM +-5% 1/16W YAGEO
R115	061G0402100 JY	RST CHIPR 10 OHM +-5% 1/16W YAGEO
R126	061G0402100 JY	RST CHIPR 10 OHM +-5% 1/16W YAGEO
R127	061G0402100 JY	RST CHIPR 10 OHM +-5% 1/16W YAGEO
R128	061G0402100 JY	RST CHIPR 10 OHM +-5% 1/16W YAGEO
R129	061G0402100 JY	RST CHIPR 10 OHM +-5% 1/16W YAGEO
R130	061G0402100 JY	RST CHIPR 10 OHM +-5% 1/16W YAGEO
R131	061G0402100 JY	RST CHIPR 10 OHM +-5% 1/16W YAGEO
R132	061G0402100 JY	RST CHIPR 10 OHM +-5% 1/16W YAGEO
R134	061G0402100 JY	RST CHIPR 10 OHM +-5% 1/16W YAGEO
R101	061G0402101 JY	RST CHIPR 100 OHM +-5% 1/16W YAGEO
R113	061G0402101 JY	RST CHIPR 100 OHM +-5% 1/16W YAGEO
R118	061G0402101 JY	RST CHIPR 100 OHM +-5% 1/16W YAGEO
R119	061G0402101 JY	RST CHIPR 100 OHM +-5% 1/16W YAGEO
R409	061G0402101 JY	RST CHIPR 100 OHM +-5% 1/16W YAGEO
R415	061G0402101 JY	RST CHIPR 100 OHM +-5% 1/16W YAGEO
R416	061G0402101 JY	RST CHIPR 100 OHM +-5% 1/16W YAGEO
R417	061G0402101 JY	RST CHIPR 100 OHM +-5% 1/16W YAGEO
R425	061G0402101 JY	RST CHIPR 100 OHM +-5% 1/16W YAGEO
R428	061G0402101 JY	RST CHIPR 100 OHM +-5% 1/16W YAGEO
R436	061G0402101 JY	RST CHIPR 100 OHM +-5% 1/16W YAGEO
R437	061G0402101 JY	RST CHIPR 100 OHM +-5% 1/16W YAGEO
R706	061G0402101 JY	RST CHIPR 100 OHM +-5% 1/16W YAGEO

R103	061G0402102 JY	RST CHIPR 1KOHM +-5% 1/16W YAGEO
R104	061G0402102 JY	RST CHIPR 1KOHM +-5% 1/16W YAGEO
R703	061G0402103 JY	RST CHIPR 10KOHM +-5% 1/16W YAGEO
R702	061G0402103 JY	RST CHIPR 10KOHM +-5% 1/16W YAGEO
R439	061G0402103 JY	RST CHIPR 10KOHM +-5% 1/16W YAGEO
R438	061G0402103 JY	RST CHIPR 10KOHM +-5% 1/16W YAGEO
R412	061G0402103 JY	RST CHIPR 10KOHM +-5% 1/16W YAGEO
R407	061G0402103 JY	RST CHIPR 10KOHM +-5% 1/16W YAGEO
R308	061G0402103 JY	RST CHIPR 10KOHM +-5% 1/16W YAGEO
R305	061G0402103 JY	RST CHIPR 10KOHM +-5% 1/16W YAGEO
R120	061G0402103 JY	RST CHIPR 10KOHM +-5% 1/16W YAGEO
R123	061G0402103 JY	RST CHIPR 10KOHM +-5% 1/16W YAGEO
R133	061G0402103 JY	RST CHIPR 10KOHM +-5% 1/16W YAGEO
R135	061G0402103 JY	RST CHIPR 10KOHM +-5% 1/16W YAGEO
R136	061G0402103 JY	RST CHIPR 10KOHM +-5% 1/16W YAGEO
R705	061G0402103 JY	RST CHIPR 10KOHM +-5% 1/16W YAGEO
R419	061G0402103 JY	RST CHIPR 10KOHM +-5% 1/16W YAGEO
R726	061G0402104 JY	RST CHIPR 100KOHM +-5% 1/16W YAGEO
R712	061G0402104 JY	RST CHIPR 100KOHM +-5% 1/16W YAGEO
R421	061G0402104 JY	RST CHIPR 100KOHM +-5% 1/16W YAGEO
R306	061G0402104 JY	RST CHIPR 100KOHM +-5% 1/16W YAGEO
R714	061G04021301FT	RST 0402 1.3K 1% 1/16W TZAI YUAN
R107	061G0402222 JY	RST CHIPR 2.2KOHM +-5% 1/16W YAGEO
R402	061G0402222 JY	RST CHIPR 2.2KOHM +-5% 1/16W YAGEO
R106	061G0402222 JY	RST CHIPR 2.2KOHM +-5% 1/16W YAGEO
R406	061G0402223 JY	RST CHIPR 22KOHM +-5% 1/16W YAGEO
R704	061G0402223 JY	RST CHIPR 22KOHM +-5% 1/16W YAGEO
R304	061G0402223 JY	RST CHIPR 22KOHM +-5% 1/16W YAGEO
R727	061G0402304 JT	RST 0402 300K 5% 1/16W TZAI YUAN
R711	061G0402333 JY	RST CHIPR 33KOHM ±5% 1/16W YAGEO
R401	061G04023900FY	RST CHIPR 390 OHM +-1% 1/16W YAGEO
R432	061G04023901FY	RST CHIPR 3.9KOHM 1% 1/16W YAGEO
R433	061G04023901FY	RST CHIPR 3.9KOHM 1% 1/16W YAGEO
R109	061G0402470 JY	RST CHIPR 47 OHM 5% 1/16W YAGEO
R114	061G0402470 JY	RST CHIPR 47 OHM 5% 1/16W YAGEO
R117	061G0402470 JY	RST CHIPR 47 OHM 5% 1/16W YAGEO
R110	061G0402471 JY	RST CHIPR 470OHM +-5% 1/16W YAGEO
R124	061G0402472 JY	RST CHIPR 4.7KOHM +-5% 1/16W YAGEO
R125	061G0402472 JY	RST CHIPR 4.7KOHM +-5% 1/16W YAGEO

R137	061G0402472 JY	RST CHIPR 4.7KOHM +-5% 1/16W YAGEO
R138	061G0402472 JY	RST CHIPR 4.7KOHM +-5% 1/16W YAGEO
R303	061G0402472 JY	RST CHIPR 4.7KOHM +-5% 1/16W YAGEO
R404	061G0402472 JY	RST CHIPR 4.7KOHM +-5% 1/16W YAGEO
R420	061G0402472 JY	RST CHIPR 4.7KOHM +-5% 1/16W YAGEO
R713	061G04026801FY	RST CHIP 6K8 1/16W 1%
R139	061G0402682 JY	RST CHIPR 6.8KOHM +-5% 1/16W YAGEO
R108	061G0402750 JY	RST CHIPR 75OHM +-5% 1/16W YAGEO
R112	061G0402750 JY	RST CHIPR 75OHM +-5% 1/16W YAGEO
R116	061G0402750 JY	RST CHIPR 75OHM +-5% 1/16W YAGEO
R102	061G0603000 JY	RST CHIPR MAX0R05 1/10W YAGEO
R707	061G0603000 JY	RST CHIPR MAX0R05 1/10W YAGEO
FB703	061G0603000 JY	RST CHIPR MAX0R05 1/10W YAGEO
R403	061G0603000 JY	RST CHIPR MAX0R05 1/10W YAGEO
R405	061G0603000 JY	RST CHIPR MAX0R05 1/10W YAGEO
R301	061G1206221 JF	RST CHIPR 220 OHM +-5% 1/4W FENGHUA
R302	061G1206221 JF	RST CHIPR 220 OHM +-5% 1/4W FENGHUA
C121	065G040210212K Y	CAP CHIP 0402 1nF K 16V X7R
C120	065G040210212K Y	CAP CHIP 0402 1nF K 16V X7R
C119	065G040210212K Y	CAP CHIP 0402 1nF K 16V X7R
C118	065G040210212K Y	CAP CHIP 0402 1nF K 16V X7R
C107	065G040210212K Y	CAP CHIP 0402 1nF K 16V X7R
C124	065G040210412K Y	CAP CHIP 0402 100N 16V X7R +/-10%
C301	065G040210412K Y	CAP CHIP 0402 100N 16V X7R +/-10%
C304	065G040210412K Y	CAP CHIP 0402 100N 16V X7R +/-10%
C403	065G040210412K Y	CAP CHIP 0402 100N 16V X7R +/-10%
C404	065G040210412K Y	CAP CHIP 0402 100N 16V X7R +/-10%
C405	065G040210412K Y	CAP CHIP 0402 100N 16V X7R +/-10%
C721	065G040210412K Y	CAP CHIP 0402 100N 16V X7R +/-10%
C717	065G040210412K Y	CAP CHIP 0402 100N 16V X7R +/-10%
C709	065G040210412K Y	CAP CHIP 0402 100N 16V X7R +/-10%
C708	065G040210412K Y	CAP CHIP 0402 100N 16V X7R +/-10%
C706	065G040210412K Y	CAP CHIP 0402 100N 16V X7R +/-10%
C705	065G040210412K Y	CAP CHIP 0402 100N 16V X7R +/-10%
C702	065G040210412K Y	CAP CHIP 0402 100N 16V X7R +/-10%
C432	065G040210412K Y	CAP CHIP 0402 100N 16V X7R +/-10%
C431	065G040210412K Y	CAP CHIP 0402 100N 16V X7R +/-10%
C422	065G040210412K Y	CAP CHIP 0402 100N 16V X7R +/-10%
C417	065G040210412K Y	CAP CHIP 0402 100N 16V X7R +/-10%

C416	065G040210412K	Y	CAP CHIP 0402 100N 16V X7R +/-10%
C415	065G040210412K	Y	CAP CHIP 0402 100N 16V X7R +/-10%
C414	065G040210412K	Y	CAP CHIP 0402 100N 16V X7R +/-10%
C413	065G040210412K	Y	CAP CHIP 0402 100N 16V X7R +/-10%
C412	065G040210412K	Y	CAP CHIP 0402 100N 16V X7R +/-10%
C411	065G040210412K	Y	CAP CHIP 0402 100N 16V X7R +/-10%
C410	065G040210412K	Y	CAP CHIP 0402 100N 16V X7R +/-10%
C409	065G040210412K	Y	CAP CHIP 0402 100N 16V X7R +/-10%
C408	065G040210412K	Y	CAP CHIP 0402 100N 16V X7R +/-10%
C407	065G040210412K	Y	CAP CHIP 0402 100N 16V X7R +/-10%
C406	065G040210412K	Y	CAP CHIP 0402 100N 16V X7R +/-10%
C115	065G040210412K	Y	CAP CHIP 0402 100N 16V X7R +/-10%
C712	065G040210427Z	T	CAP CHIP 0402 0.1UF 25V Y5V
C713	065G040210427Z	T	CAP CHIP 0402 0.1UF 25V Y5V
C719	065G040210427Z	T	CAP CHIP 0402 0.1UF 25V Y5V
C722	065G040215131J	Y	CHIP 150pF 50V NPO YAGEO
C103	065G040222031J	Y	CAP CHIP 0402 22P 50V NPO +/-5%
C104	065G040222031J	Y	CAP CHIP 0402 22P 50V NPO +/-5%
C116	065G040222417Z	Y	CAP CHIP 0402 220nF 16V Y5V
C117	065G040222417Z	Y	CAP CHIP 0402 220nF 16V Y5V
C303	065G040222417Z	Y	CAP CHIP 0402 220nF 16V Y5V
C401	065G040222417Z	Y	CAP CHIP 0402 220nF 16V Y5V
C714	065G040227232K	A	CAP CHIP 0402 2.7NF K 50V X7R
C714	065G040227232K	T	CAP CHIP 0402 2700pF 50V X7R
C420	065G040247031J	Y	CAP CHIP 0402 47pF 50V NPO +/-5%
C421	065G040247031J	Y	CAP CHIP 0402 47pF 50V NPO +/-5%
C102	065G040247312K	T	CAP CHIP 0402 0.047uF 16V X7R
C106	065G040247312K	T	CAP CHIP 0402 0.047uF 16V X7R
C108	065G040247312K	T	CAP CHIP 0402 0.047uF 16V X7R
C110	065G040247312K	T	CAP CHIP 0402 0.047uF 16V X7R
C111	065G040247312K	T	CAP CHIP 0402 0.047uF 16V X7R
C114	065G040247312K	T	CAP CHIP 0402 0.047uF 16V X7R
C113	065G040250931J	Y	CAP CHIP 0402 5PF 50V NPO
C109	065G040250931J	Y	CAP CHIP 0402 5PF 50V NPO
C105	065G040250931J	Y	CAP CHIP 0402 5PF 50V NPO
C715	065G060310232K	Y	CAP CHIP 0603 1N 50V X7R +/-10%
C305	065G060310512K	3	MLCC 0603 CAP 1uF K 16V X7R
C419	065G0805106A7Z	T	CAP CHIP 0805 10UF Z 10V Y5V
C402	065G0805106A7Z	T	CAP CHIP 0805 10UF Z 10V Y5V

C723	065G120610625K T	CAP CHIP 1206 10uF K 25V X5R
C720	065G120610625K T	CAP CHIP 1206 10uF K 25V X5R
C707	065G120622615K M	CAP CHIP 1206 22UF K 16V X5R
C704	065G120622615K M	CAP CHIP 1206 22UF K 16V X5R
C302	065G120622615K M	CAP CHIP 1206 22UF K 16V X5R
C707	065G120622615K T	CAP CHIP 1206 22UF K 16V X5R
C704	065G120622615K T	CAP CHIP 1206 22UF K 16V X5R
C302	065G120622615K T	CAP CHIP 1206 22UF K 16V X5R
FB301	071G 56K121	CHIP BEAD
FB408	071G 56K121	CHIP BEAD
FB401	071G 56V301 B	CHIP BEAD FCM2012VF-301T07 bullwill
FB402	071G 56V301 B	CHIP BEAD FCM2012VF-301T07 bullwill
FB404	071G 56V301 B	CHIP BEAD FCM2012VF-301T07 bullwill
FB106	071G 59G301	CHIP BEAD 300OHM
FB105	071G 59G301	CHIP BEAD 300OHM
FB104	071G 59G301	CHIP BEAD 300OHM
FB101	071G 59K190 B	19 OHM BEAD
FB102	071G 59K190 B	19 OHM BEAD
FB103	071G 59K190 B	19 OHM BEAD
FB406	071G 59S601 T	CHIP BEAD 600R/500mA MMZ1608S601CT
FB405	071G 59S601 T	CHIP BEAD 600R/500mA MMZ1608S601CT
L701	073G253S 36 H HF	SMD CHOKE 22uH HF
D101	093G 64 42 L	DIODE LBAV70LT1G SOT-23 LRC
D102	093G 64 42 L	DIODE LBAV70LT1G SOT-23 LRC
D101	093G 64 42 PP	BAV70 SOT-23
D102	093G 64 42 PP	BAV70 SOT-23
ZD101	093G 39GA01 T	RLZ5.6B
D701	093G3004 3	SM340A
D703	093G3004 3	SM340A
D704	093G3004 3	SM340A
D707	093G3004 3	SM340A
D708	093G3004 3	SM340A
CN301	311GW125A30ACH	WAFER 1.25mm 30P
FQ004	KEPC9QPJ	KEY BOARD ASSY
CN001	033G8032 6F S HR	CONNECTOR
U001	056G 665 43	IC CY8C20180-LDX2I QFN-16(COL)
U001	056G 669 10	IC CG7246AM QFN-16(COL)
R007	061G0603153 JT	RST CHIPR 15KOHM 1/10W TZAI YUAN
R001	061G0603561 JY	RST CHIP 560R 1/10W 5% YAGEO

R002	061G0603561 JY	RST CHIP 560R 1/10W 5% YAGEO
R003	061G0603561 JY	RST CHIP 560R 1/10W 5% YAGEO
R004	061G0603561 JY	RST CHIP 560R 1/10W 5% YAGEO
R005	061G0603561 JY	RST CHIP 560R 1/10W 5% YAGEO
C001	065G060310231J M	CAP CHIP 0603 1000pF J 50V NPO
C003	065G060310437Z Y	CAP CHIP 0603 100N 50V Y5V -20%+80%
C002	065G060310605M T	MLCC 0603 10UF 6.3V X5R +-20%
C002	065G060310605M Y	CAP CHIP 0603 10uF 6.3V X5R +/-20%
LED001	081G 14 30 EL	CHIP LED YELLOW / WHITE
ZD002	093G 39S 34 T	UDZSNP5.6B ROHM
ZD003	093G 39S 34 T	UDZSNP5.6B ROHM
ZD004	093G 39S 34 T	UDZSNP5.6B ROHM
ZD001	093G 39S 34 T	UDZSNP5.6B ROHM
FQ011	LNPCA8451AQAE	CONVERTER BOARD ASSY
C802	067G215C1016KV	EC 100UF 20% 35V EM 8*9
C804	067G215C4799KV	EC 4.7UF 20% 100V EM 8*9
CN802	033G801910Y H	FPC CONN. 0.5mm SMT 10P
CN801	033G803210F HR	CONNECTOR
IC801	056G 379167	IC TA9690GN-A1-0-TR SOP-24
Q801	057G 763 92	FET P8008HV 4A/80V SOP-8
R844	061G0603000 JT	RST CHIP MAX 0R05 1/10W TZAI YUAN
R811	061G0603000 JT	RST CHIP MAX 0R05 1/10W TZAI YUAN
R807	061G0603000 JT	RST CHIP MAX 0R05 1/10W TZAI YUAN
R844	061G0603000 JY	RST CHIPR MAX0R05 1/10W YAGEO
R823	061G0603000 JY	RST CHIPR MAX0R05 1/10W YAGEO
R814	061G0603100 JF	RST CHIPR 10 OHM 5% 1/10W FENGHUA
R812	061G0603101 JY	RST CHIPR 100 OHM +-5% 1/10W YAGEO
R810	061G0603102 JT	RST CHIP 1K 1/10W 5% TZAI YUAN
R813	061G0603103 JT	RST CHIP 10K 1/10W 5% TZAI YUAN
R806	061G0603103 JT	RST CHIP 10K 1/10W 5% TZAI YUAN
R809	061G0603104 JT	RST CHIP 100K 1/10W 5% TZAI YUAN
R833	061G0603109 JY	RST CHIPR 1 OHM +-5% 1/10W YAGEO
R831	061G0603109 JY	RST CHIPR 1 OHM +-5% 1/10W YAGEO
R829	061G0603109 JY	RST CHIPR 1 OHM +-5% 1/10W YAGEO
R828	061G0603109 JY	RST CHIPR 1 OHM +-5% 1/10W YAGEO
R827	061G0603109 JY	RST CHIPR 1 OHM +-5% 1/10W YAGEO
R826	061G0603109 JY	RST CHIPR 1 OHM +-5% 1/10W YAGEO
R805	061G0603124 JY	RST CHIPR 120KOHM 1/16W YAGEO
R824	061G06033902FF	RST CHIPR 39KOHM +-1% 1/10W FENGHUA

R822	061G08051004FT		RST CHIP R 1 MOHM +-1% 1/8W
R825	061G1206000 JF		RST CHIPR MAX0R05 1/4W FENGHUA
R801	061G12061507FF		RST CHIPR 0.15 OHM +-1% 1/4W FENGHUA
C816	065G060310432K	A	CAP CHIP 0603 100nF K 50V X7R
C805	065G060347412K	3	CAP CHIP 0603 0.47uF K 16V X7R
C801	065G080510432K	3	CAP CHIP 0805 100N 50V X7R +/-10%
C807	065G080522512K	T	CAP CHIP 0805 2.2UF K 16V X7R
C806	065G080522525K	T	CAP CHIP 0805 2.2uF K 25V X5R
L801	073G253S 80 H		SMD CHOKE 22uH 2.16A SPI103LRR-220
L801	073G253S 80 DN		SMD CHOKE 22uH 2.16A LZ.3A220.A1P HF
ZD801	093G 60S 31 T		DIODE B360B 3A/60V SMB
E715	715G3823P04000004W		CONVERTER PCB FR4 110X40X1.6MM DS
R822	061G08051004FF		RST CHIPR 1 MOHM +-1% 1/8W FENGHUA
C803	065G080510432K	Y	CAP CHIP 0805 100N 50V X7R +/-10%
C810	065G080510432K	Y	CAP CHIP 0805 100N 50V X7R +/-10%
C803	065G080510432K	F	CAP CHIP 0805 0.1UF K 50V X7R
C810	065G080510432K	F	CAP CHIP 0805 0.1UF K 50V X7R
R804	061G06035102FF		RST CHIPR 51KOHM +-1% 1/10W FENGHUA
R842	061G06036802FF		RST CHIPR 68KOHM +-1% 1/10W FENGHUA
R804	061G06035102FY		RST CHIPR 51KOHM +-1% 1/10W YAGEO
R842	061G06036802FY		RST CHIPR 68KOHM +-1% 1/10W YAGEO
R824	061G06033902FY		RST CHIPR 39KOHM +-1% 1/10W YAGEO

Service Kit

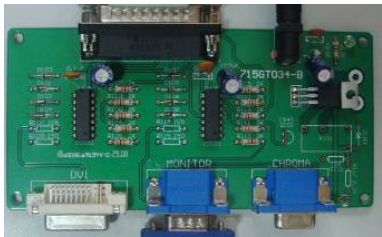
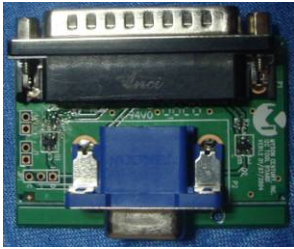
Description	Part No.	Picture
EDID KIT	715GT034-B	
MSTAR ISP KIT	715GT039-A	

17. Different Parts List

Diversity of 191E2SB/10 compared with 191E2SB/00					
191E2SB/10			191E2SB/00		
Location	PCM Codes	Description	Location	PCM Codes	Description

Diversity of 191E2SB/27 compared with 191E2SB/00					
191E2SB/27			191E2SB/00		
Location	PCM Codes	Description	Location	PCM Codes	Description

Diversity of 191E2SB/62 compared with 191E2SB/00					
191E2SB/62			191E2SB/00		
Location	PCM Codes	Description	Location	PCM Codes	Description
FQ002	756GQACB PH050 00	SCALER BOARD ASSY(CBPCAM6PHQ2)	FQ002	756GQ9CB PH131 00	SCALER BOARD ASSY(CBPCAM6PHQ1)
U402	100GPMG8001NT1	MCU ASSY(056G1133129)	U402	100GPMG8000NT1	MCU ASSY(056G1133129)
FQ010	ADPC91236YA1	ADAPTER BOARD ASSY	FQ010	ADPCA1236YQAX	ADAPTER BOARD ASSY
FQ105	Q34G7111AFLA9B0100	REAR COVER	FQ105	Q34G7111AFLA5B0100	REAR COVER

Diversity of 191E2SB/69 compared with 191E2SB/00					
191E2SB/69			191E2SB/00		
Location	PCM Codes	Description	Location	PCM Codes	Description
FQ301	089G418A15NISJ	AC POWER CORD 1500	FQ301	089G404A15N IS	AC POWER CORD 1500MM Europe Reg.

Diversity of 191E2SB/71 compared with 191E2SB/00					
191E2SB/71			191E2SB/00		
Location	PCM Codes	Description	Location	PCM Codes	Description

Diversity of 191E2SB/73 compared with 191E2SB/00					
191E2SB/73			191E2SB/00		
Location	PCM Codes	Description	Location	PCM Codes	Description

Diversity of 191E2SB/75 compared with 191E2SB/00					
191E2SB/75			191E2SB/00		
Location	PCM Codes	Description	Location	PCM Codes	Description

Diversity of 191E2SB/94 compared with 191E2SB/00					
191E2SB/94			191E2SB/00		
Location	PCM Codes	Description	Location	PCM Codes	Description

Note: The BOMs of 191EL2SB/01, 191EL2SB/55 and 191EL2SB/70 are the same as the 191EL2SB/00.

Diversity of 191EL2SB/10 compared with 191EL2SB/00					
191EL2SB/10			191EL2SB/00		
Location	PCM Codes	Description	Location	PCM Codes	Description
FQ405	A33G0797 GM 1L0100	KEY PAD	FQ405	A33G0797AFL 1L0100	KEY
FQ106	Q34G7110AFL 8B0100	BEZEL	FQ106	Q34G7110AFLA8B0130	BEZEL
FQ105	Q34G7111 GM 3K0100	REAR COVER	FQ105	Q34G7111AFLA3B0100	REAR COVER
FQ202	Q44G8054624 1A	PHILIPS 18.5 LCD CARTON	FQ202	Q44G8054813 3A	PHILIPS 18.5 LCD CARTON

Diversity of 191EL2SB/27 compared with 191EL2SB/00					
191EL2SB/27			191EL2SB/00		
Location	PCM Codes	Description	Location	PCM Codes	Description
FQ405	A33G0797 GM 1L0100	KEY PAD	FQ405	A33G0797AFL 1L0100	KEY
FQ106	Q34G7110AFL 8B0100	BEZEL	FQ106	Q34G7110AFLA8B0130	BEZEL
FQ105	Q34G7111 GM 4K0100	REAR COVER	FQ105	Q34G7111AFLA3B0100	REAR COVER

Diversity of 191EL2SB/67 compared with 191EL2SB/00					
191EL2SB/67			191EL2SB/00		
Location	PCM Codes	Description	Location	PCM Codes	Description
E08901	089G402A15N IS	POWER CORD 1.5M	FQ301	089G404A15N IS	POWER CORD I-SHENG

Diversity of 191EL2SB/69 compared with 191EL2SB/00					
191EL2SB/69			191EL2SB/00		
Location	PCM Codes	Description	Location	PCM Codes	Description
FQ301	089G418A15NISJ	AC POWER CORD 1500	FQ301	089G404A15N IS	POWER CORD I-SHENG

Diversity of 191EL2SB/71 compared with 191EL2SB/00					
191EL2SB/71			191EL2SB/00		
Location	PCM Codes	Description	Location	PCM Codes	Description
FQ301	089G401A15NISA	POWER CORD 1.8M	FQ301	089G404A15N IS	POWER CORD I-SHENG

Diversity of 191EL2SB/75 compared with 191EL2SB/00					
191EL2SB/75			191EL2SB/00		
Location	PCM Codes	Description	Location	PCM Codes	Description
FQ301	089G412A15NIS3	AC POWER CORD 1500MM	FQ301	089G404A15N IS	POWER CORD I-SHENG

Diversity of 191EL2SB/78 compared with 191EL2SB/00					
191EL2SB/78			191EL2SB/00		
Location	PCM Codes	Description	Location	PCM Codes	Description

Diversity of 191EL2SB/93 compared with 191EL2SB/00					
191EL2SB/93			191EL2SB/00		
Location	PCM Codes	Description	Location	PCM Codes	Description
FQ301	089G414A15N IS	POWER CORD 1500MM China Reg.	FQ301	089G404A15N IS	POWER CORD I-SHENG

Diversity of 191EL2SB/94 compared with 191EL2SB/00					
191EL2SB/94			191EL2SB/00		
Location	PCM Codes	Description	Location	PCM Codes	Description
FQ301	089G417A15N IS	POWER CORD	FQ301	089G404A15N IS	POWER CORD I-SHENG

Diversity of 191EL2SB/96 (1A+1D) compared with 191EL2SB/00					
191EL2SB/96 (1A+1D)			191EL2SB/00		
Location	PCM Codes	Description	Location	PCM Codes	Description
FQ301	089G420A15N IS	AC POWER CORD 1500MM TAIWAN	FQ301	089G404A15N IS	POWER CORD I-SHENG

Diversity of 191EL2SB/96 (1A) compared with 191EL2SB/00					
191EL2SB/96 (1A)			191EL2SB/00		
Location	PCM Codes	Description	Location	PCM Codes	Description
FQ301	089G420A15N IS	AC POWER CORD 1500MM TAIWAN	FQ301	089G404A15N IS	POWER CORD I-SHENG
FQ010	ADPC91236YA1	ADAPTER BOARD ASSY	FQ010	ADPCA1236YQAX	ADAPTER BOARD ASSY
FQ002	756GQACB PH051 00	SCALER BOARD ASSY (CBPCAM6PHQ2)	FQ002	756GQ9CB PH132 00	SCALER BOARD ASSY (CBPCAM6PHQ1)
U402	100GPMA8001NT1	MCU ASSY (056G1133129)	U402	100GPMA8000NT1	MCU ASSY (056G1133129)
FQ105	Q34G7111AFLA7B0100	REAR COVER	FQ105	Q34G7111AFLA3B0100	REAR COVER

18. General Product Specification

Blue: changes in this version

Red: open/reminding

- ANALOG AND DIGITAL INPUT (DVI CAN BE OPTIONAL)
- AUTO PICTURE ADJUSTMENT
- **18 FACTORY PRESET MODES and 33 USER MODES**
- USER FRIENDLY OSD DISPLAY FOR MODE IDENTIFICATION/ADJUSTMENT
- MAX. RESOLUTION 1366 x 768 NON-INTERLACED AT 76 Hz
- **18.5"** WIDE COLOR TFT LCD FLAT PANEL
- FULL RANGE POWER SUPPLY 90 - 264 VAC
- CE ENVIRONMENTAL POLICY
- ANTI-GLARE TO REDUCE LIGHT REFLECTION
- POWER MANAGEMENT CAPABILITY
- SOG SUPPORT
- Windows Vista Premium Logo Certification for Dual models
Windows Vista Basic Logo Certification for Analog models.
- HDCP support for DVI input
- SmartContrast > 500K:1(Typical)
- TrueVision™ (formerly PerfectTuneII or FGA, FACTORY GAMMA ALIGNMENT)
- WEEE REQUIREMENT
- RoHS REQUIREMENT
- **TCO 06 REQUIREMENT**
- POWER ON PHILIPS LOGO REQUIREMENT
- WEEE REQUIREMENT
- RoHS REQUIREMENT

CONTENTS**1. Foreword****2. Product Profile**

2.1 LCD

2.2 Scanning Frequencies

2.3 Ambient Temperature: 0 °C - 40 °C

3. Electrical Characteristics

3.1 Interface Signals

3.2 Interface

3.3 Timing Requirement

3.4 Horizontal Scanning

3.5 Vertical Scanning

3.6 Power Input Connection

3.7 Power management (Supplier to Input)

3.8 VGA Display Identification

3.9 DDC/CI Support

3.10 Data for EDID & inf file

3.11 Hot-key Definition

4. Visual Characteristics

4.1 Test Conditions

4.2 Brightness

4.3 Image Size

4.4 Brightness Uniformity

4.5 Check Cross Talk (S)

4.6 White Color Adjustment

5. Mechanical Characteristics

5.1 Cosmetic

5.2 Mechanical Data Files

5.3 Location of Philips Logo

5.4 Gap between Panel and Front Bezel

5.5 Location Control Icons

5.6 Color for Resin/Paint

5.7 Fire Enclosure Request

5.8 Resins

5.9 If Paint is used

5.10 Plastic Mold Tooling

5.11 Plastics Flammability

5.12 Texture/Glossing of House

5.13 Tilt and Swivel Base

5.14 Kensington Lock

5.15 Label

5.16 Product Dimension / Weight (refer to Philips approved SHT 191/SHT560)

5.17 Transportation

5.18 Pallet / Container Loading (Refer to Philips approved SHT 560)

6. Environmental Characteristics

6.1 Susceptibility of Display to External Environment

6.2 Transportation Tests

6.3 Display Disturbances from External Environment

6.4 Display Disturbances to External Environment

7. Reliability

7.1 Mean Time between Failures

8. Quality Assurance Requirements

8.1 Acceptance Test

9. Philips' Flat Panel Monitors Pixel Defect Policy

10. Regulatory Compliance

10.1 Worldwide Regulatory

10.2 EMC Requirements

10.3 RoHS

10.4 WEEE

10.5 Ongoing Regulatory

1. Foreword

This specification describes an **18.5" WXGA** multi-scan color TFT LCD monitor with maximum resolution up to 1366*768 /75 Hz non-interlaced.

All optical characteristics (including WHITE-D, Brightness, and so on) are determined according to panel specification after warming up approximate 30 minutes that brightness stability is optimal, and follow strictly after panel specification.

2. Product Profile

This display monitor unit is a color display monitor enclosed in PHILIPS styling front cabinet, the other are TPV OTS.

2.1 LCD

For 191E2

Tier1: LG	
Type NR.	: LM185WH1-TLF1
Outside dimensions	: 430.4(H) * 254.6(V) * 13.0 (D)
Pitch (mm)	: 0.3 (H) x 0.3 (V)
Color pixel arrangement	: RGB vertical stripes
Display surface	: Hard coating (3H), Anti-glare treatment of the front polarizer
Color depths	: 16.7M colors
Backlight	: CCFL edge light system
Active area	: 409.8 (H) x 230.4 (V)
View angle	: Horizontal 170 (typ.), Vertical 160 (typ.)
Contrast ratio	: 1000:1(typical)
White luminance	: 250 nits (typ.)
Gate IC	:
Source IC	:
Response time	: 5ms (typ.)
MTBF	: 50,000 Hrs

For 191EL2

Tier1: AUO	
Type NR.	: M185XW01 V6
Outside dimensions	: 430.4(H) * 254.6(V) * 9.9 (D)
Pitch (mm)	: 300 (H) x 300 (V)
Color pixel arrangement	: RGB vertical stripes
Display surface	: Hard coating (3H), Anti-glare treatment of the front polarizer
Color depths	: 16.7M colors
Backlight	: CCFL edge light system
Active area	: 409.8 (H) x 230.4 (V)
View angle	: Horizontal 170 (typ.), Vertical 160 (typ.)
Contrast ratio	: 1000:1(typical)
White luminance	: 250 nits (typ.)
Gate IC	:
Source IC	:
Response time	: 5ms (typ.)
MTBF	: 50,000 Hrs

2.2 Scanning frequencies

- Hor. : 30 - 83 K Hz
- Ver. : 56 - 76 Hz
- Video dot rate : <140 MHz
- Power input : 90-264 V AC, 50/60 ± 2 Hz
- Power consumption : <16.6W (typ.), < TBDW (max)
EPA 5.0 TBD WATT

Functions:

- (1) D-SUB analog R/G/B separate inputs, H/V sync separated, Composite (H+V) TTL level, SOG sync
- (2) (2) DVI digital Panel Link TMDS inputs

2.3 Ambient temperature: 0 °C - 40 °C

3. Electrical Characteristics

3.1 Interface signals

1). D-Sub Analog

- Input signal : Video, Hsync, Vsync
- Video : 0.7 Vp-p, input impedance, 75 ohm @DC
- Sync. : Separate sync TTL level, input impedance 2.2k ohm terminate
- Hsync Positive/Negative
- Vsync Positive/Negative
- Composite sync TTL level, input impedance 2.2k ohm terminate (Positive/Negative)
- Sync on green video 0.3 Vp-p Negative (Video 0.7 Vp-p Positive)

2) DVI-D Digital

- Input signal : Single TMDS link (Three channels: RX0-/+ , RX1-/+ , RX2-/+)

3) Audio

- Input signal: 1000 mVrms
- Loudspeaker (Impedance: 8 Ohm +/-15%): 1.5 W+1.5 W stereo for RMS Power
- Frequency range: 450Hz - 20 KHz

3.2 Interface

3.2.1 D-Sub Cable

- Length : 1.8 M +/- 50 mm
- Fix with monitor when packing, with transplant pin protective cover.
- Connector type : D-Sub male with DDC2B pin assignments.
Blue connector thumb-operated jack screws

Pin assignments:

PIN No.	Description	PIN No.	Description
1	Red	9	DDC +3.3V or +5V
2	Green/ SOG	10	Logic GND
3	Blue	11	Sense (GND)
4	Sense (GND)	12	Bi-directional data
5	Cable Detect (GND)	13	H/H+V sync
6	Red GND	14	V-sync
7	Green GND	15	Data clock
8	Blue GND		

3.2.2 DVI -D Cable

The input signals are applied to the display through DVI-D cable.

Length : 1.8 M +/- 50 mm

Connector type : DVI-D male with DDC-2B pin assignments
White connector thumb-operated jackscrews

Pin Assignment:

Pin No.	Description	Pin No.	Description
1	T.M.D.S. data2-	13	No Connect
2	T.M.D.S. data2+	14	+5V Power
3	T.M.D.S. data2 shield	15	Ground (for +5V)
4	No Connect	16	Hot plug detect
5	No Connect	17	T.M.D.S. data0-
6	DDC clock	18	T.M.D.S. data0+
7	DDC data	19	T.M.D.S. data0 shield
8	No Connect	20	No Connect
9	T.M.D.S. data1-	21	No Connect
10	T.M.D.S. data1+	22	T.M.D.S clock shield
11	T.M.D.S. data1 shield	23	T.M.D.S. clock+
12	No Connect	24	T.M.D.S. clock-

3.3 Timing requirement

Factory Preset mode definition:

- a. Perfect FOS while presenting all required timings.
- b. Required timings need to be specified in User's Manual

User mode

- a. Can be showed (not over scalar or Panel spec.)
- b. It needs to reserve the 22 timings space in memory size.

3.3.1 Mode storing capacity

- a. Factory preset modes : 18
- b. User modes : 33

Note:

- 11. Screen displays perfect picture at factory-preset modes.
- 12. Screen displays visible picture with OSD warning when input modes are the 22reset modes

3.3.2 Factory preset modes

Factory modes and preset modes are defined in the enclosed timing table file



191E2.xls





Video timing mode (internal firmware support),

60Hz: 480p/720p/1080i/1080p

50Hz: 576p/720p/1080i/1080p

3.3.3 Software control functions via OSD / control adjustable functions:

Please refer to following Hudson9 OSD definitions, if any deviation, then refer to PVT Exit sample.

ITEM			
1	OSD DEFINITIONS	 M2 OSD Button definition _ 20100120	Reset - No: Exit Yes: Auto adjustment for displaying timing mode and recall factory preset
2	OSD LANGUAGES	 H8 OSD translation - 20070425 - Final.xls  H9 new item translation _ 2008041	9 LANGUAGES
3	OSD TREE	 191E2 OSD TREE-100309.xls	
4	POWER ON LOGO	 19W_1366x768_ new.zip	Power On Logo: Power On → Show up Philips logo 3 seconds → Change to input signal. This picture is reference only. The official drawing will send out by PM.

3.3.4 Touch key control

a. Power On

- A user press the power key
- LEDs of all functional keys and Power key are all ON
- After 12 sec, LEDs of functional keys are OFF, Power key LED remain ON
- The LED OFF behavior is to smoothly off, time period is 2sec

b. Users operations

- A user press one of functions keys
- All LEDs of functional keys are ON during the user operation
- No user operations found, LEDs of functional keys are smoothly OFF after the OSD (not including message notice) is disappeared 3sec.

c. Standby

1. First edition:

Amber all ON

2. Next edition:

- Power LED blinking (3 sec. on, 3sec. off)
- When users to press any functional key, all LEDs ON and the set back to ON state to do operational checking

d. Power off

- A user press the power key
- All LEDs are OFF immediately

3.4 Horizontal scanning

Sync polarity : Positive or Negative
Scanning frequency : **30 -83 K Hz**

3.5 Vertical scanning

Sync polarity : Positive or Negative
 Scanning frequency : **56 - 76 Hz**

3.6 Power input connection

Power cord length : 1.5M
 Power cord type : 3 leads power cord with protective earth plug.

3.7 Power management (supplier to input)

The monitor must comply with the Microsoft On Now specification, and meet EPA requirements.

Mode	Hsync	Vsync	Video	Pwr-cons.	Indication	Rec. time
Power-On	On	On	active	<16.6W Typ. EPA5.0 TBD W	Blue LED	--
Power saving	Off	Off	blanked	< 0.5 W	Amber LED	< 3 s
DC Power Off			N/A	< 0.5 W	LED Off	

* Energy star 5.0 report less than TBD watt

3.8 VGA Display identification

In accordance with VESA Display Channel Standard Ver.1.0 and DDC 2B capability

3.9 DDC /CI Support

In accordance with VESA DDC/CI and MCCS ver.2.0

3.10 Data for EDID & INF file

1	User visible strings on .inf file	Philips 191E (19inch WIDE LCD MONITOR 191E2)
2	Manufacturer ID (EDID data)	PHL
3	Product ID, "xxxx" 4 codes	MSB(byte 12): C0 LSB (byte 11): 4F
4	maximum resolution	1366x768
5	Horizontal Frequency Range	30~83 KHz
6	Vertical Frequency Range	56~76Hz
7	Monitor Name (13 characters max.)	Philips 191E

3.11 Hot-key definition



Hot key definition .xlsx

Any deviation between document and sample, please refer to Philips approved sample.

3.12 SmartImage Lite

3.12.1 SmartImage Lite OSD outlook

SmartImage Lite
Standard
Internet
Game

Default: Standard

Position

The position of the button is at the bottom center of the screen.

SmartImage Lite Logo & Banner

As design to keep the LightFrame logo at header but change the name to “SmartImage” with bitmap format.

Icon of each profile

Each profile will use text instead of icon & text before.

User Operation Procedure

- A. 3 different modes are switched to next in the sequence from 1 to 3 then back to 1 while pressing this button: 1) Standard 2) Internet 3) Game. The default setting is “Standard”.
 - B. The FOS optimization will be changed in real time by which profile to be scrolled, users don't need to confirm to enable.
 - C. The SmartImage Lite OSD will remain on screen for 5 seconds after user last action. Or user can also press [MENU] to close the Smart Image OSD immediately.
 - D. Except using [MENU] button to scroll down profile. If Smart Image OSD already launched onscreen. User is allowed to use up/down key to choose profile and press [MENU] to confirm selection and close the Smart Image OSD.
 - E. If the model has multiple inputs including VGA and DVI, each input has their own set of profiles. When user switch input, the profile to be applied will also change.
 - F. Each input can memorize their individual “SmartImage Lite” profile status.
- For example, SmartImage is on with “Game” profile at VGA input, when switch to DVI input, the Smart Image will revert to previous profile of DVI.

In the input switching process the “SmartImage” OSD will also show up to present which profile is selected if “Smart Image” is enabled at that input.

The Smart Image status will also be stored after the monitor is resumed from AC on/off or power switch on/off.

Linkage between SmartImage Lite OSD and main OSD

- A. Settings within main OSD have linkage with Smart Image OSD.
 - i. Brightness
 - ii. Contrast
 - iii. Color Temperature
- B. Because each preset profiles will define default setting of these 3 parameters. Users can understand the value of that in preset profile by open the main OSD.
- C. When any SmartImage Lite profile had been enabled. The parameters in main OSD are still available for user to adjust. But these adjustments are temporary only. If users switch to another profile and then go back. The setting in main OSD will show preset values of that SmartImage profile enabled.

Profile Definitions (system integrators to input at design stages)**A. Standard**

- i. Purpose: Default out of box settings, No optimization by SmartImage.
- ii. Design:
 1. This will follow user OSD setting. If any change by user, it will be saved. When switch back from other SmartImage profiles, it will go back to last saved setting.
 2. Default out of box settings
 3. Same as OFF mode settings in SmartImage

B. Internet

- i. Purpose: Design for Internet application, especially web browsing.
The screen is mixed by text & picture. Desktop publish could use this profile also.
- ii. Enhancement Point:
 1. The enhancement will be mostly based on the "Image viewing" settings that are also under definition, made milder by the higher probability of strong compression typical of the Internet photos and clips.
 2. Color temperature should be 6500° K
 3. Brightness level should be around 90%
 4. SmartResponse set to "Low".
 5. Smart Contrast set to "Off".

C. Game

- i. Purpose: Design for PC game software and game boxes, e.g. PS3 and Xbox. The screen is dominated by artificial animation with rich color.
- ii. Enhancement Point:
 1. Dynamic contrast enhancement by histogram analysis should be implemented.
 2. Sharpness enhanced 90%.
 3. Color enhancement set as the same with Video.
 4. Color temperature set to panel native(original color temp)
 5. Brightness level sets to maximum.
 6. SmartResponse set to "High"
 7. Gamma Table turns off to achieve fastest response time.
 8. SmartContrast set to "On"

Demo mode

- A. Purpose: Built-in demo mode for sales in-store demo.
- B. Design:
 - i. Dynamically split screen to 2 vertical frames with one vertical white line. The line width is 2 pixels. The left frame will be enhanced by SmartImage Lite and right frame remains original performance.
 - ii. There is OSD showing "SmartImage Lite & SmartResponse Demonstration" in left frame and "Original Image" in right frame.
 - iii. The OSD word color is white with transparent background.
 - iv. The demo profile will be "Video Playback" profile with "High" ODC setting.
 - v. The current SmartContrast value also is shown on the bottom of the screen.
- C. Hot keys to trigger:

Press [Smart Image] 3 seconds or more to trigger the demo mode.
When demo mode is On, press 3 seconds or more to turn off the demo mode.

4. Visual Characteristics**4.1 Test conditions**

Unless otherwise specified, this specification is defined under the following conditions.

- (1) Input signal: As defined in 3.3, 1366 x 768 non-interlaced mode (1366 x 768@60Hz 146.25MHz), signal sources must have 75 ohm output impedance.
- (2) Luminance setting: controls to be set to 300 nits with full screen 100 % duty cycle white signal
- (3) Warm up: more than 30 minutes after power on with signal supplied.
- (4) Ambient light: 400 – 600 lux.
- (5) Ambient temperature: 20 ± 5 °C

4.2 Brightness

Follow Panel specification.

4.3 Image size

Actual display size: refer to **2.1 LCD panel spec.**

4.4 Brightness uniformity

Set contrast at 100% and turn the brightness to get average above 300 nits at centre of the screen.

Apply the Fig 1; it should comply with the following formula:

$$\frac{(B_{max} - B_{min})}{B_{max}} \times 100\% > 75\%$$

Where B_max = Maximum brightness
 B_min = Minimum brightness

4.5 Check Cross talk (S)

Apply Pattern 2. Set contrast and brightness at 100 %.

Measure YA. Then output Pattern 3 and measure YB.

The cross talk value:

$$\frac{ABS(YA - YB)}{YA} \times 100\% < 1.5\%$$

4.6 White Color Adjustment

There are three factory preset white color 9300K, 6500K, sRGB.

Apply full gray 64 pattern, with brightness in 100 % position and the contrast control at 50 % position.

The 1931 CIE Chromaticity (color triangle) diagram (x, y) coordinate for the screen center should be:

Product specification

CIE coordinates	(x,y)
9300K	x = 0.283 ± 0.02 y = 0.297 ± 0.02
6500K/sRGB	x = 0.313 ± 0.02 y = 0.329 ± 0.02
sRGB	x = 0.313 ± 0.02 y = 0.329 ± 0.02

Production alignment specification

CIE coordinates	(x,y)
9300K	x = 0.283 ± 0.005 y = 0.297 ± 0.005
6500K/sRGB	x = 0.313 ± 0.005 y = 0.329 ± 0.005
sRGB	x = 0.313 ± 0.005 y = 0.329 ± 0.005

Quality Inspection specification:

CIE coordinates	(x,y)
9300K	x = 0.283 ± 0.015 y = 0.297 ± 0.015
6500K/sRGB	x = 0.313 ± 0.015 y = 0.329 ± 0.015
sRGB	x = 0.313 ± 0.015 y = 0.329 ± 0.015

5. Mechanical Characteristics**5.1 Cosmetic -**

Philips ID

5.2 Mechanical data files -

ProE files required

5.3 Location of Philips logo -

Per Philips make-up sheet

5.4 Gap between panel and front bezel

< 1.4mm (max.)

5.5 Location of Control icons -

Per Philips Graphic sheet

5.6 Color for resin/paint -

Per Philips make-up sheet

5.7 Fire enclosure request

Shielding Cover should fulfill international standard

5.8 Resins

- RoHS required
- WEEE required.
- Resin type/selection refers to Project Book Section 7.2 Plastic material.

5.9 If paint is used

- RoHS required
- WEEE require
- If new painting type needs to implement, refer to UN-D 1235.

5.10 Plastic mold tooling

- Tooling to be designed to minimize cosmetic defects induced by molding process (sink, blush, weld lines, gate marks, ejector marks, etc.). Refer to "TYV61-90007".
- Painting to cover up cosmetic defects due to molding is strongly discouraged.
- China RoHS mark requested.

5.11 Plastics flammability

- All Plastics to be Flame Retardant UL 94-HB.
- Base / Pedestal to be Flame Retardant UL 94-HB.
- All major plastic parts (bezel, back cover) need to be molded from same resin.
- Plastic resin type selection should be referred to "plastic-Philips Pool monitor".

5.12 Texture/Glossing of housing

- The texture area and texture no should follow Philips make-up sheet.
- The exterior surfaces shall have a uniform texture.
- Philips must approve the mold texturing.
- Detail document for texture refer to "UN-D249", "UN-D 600".
- > = 80 gloss units

5.13 Tilt and swivel base

- Tilt angle: $-5^\circ + 2/- 0^\circ$ (forward)
 $+20^\circ + 0/- 3^\circ$ (backward)
- Tilt for left and right:
 $| A-B | \leq 4.0\text{mm}$

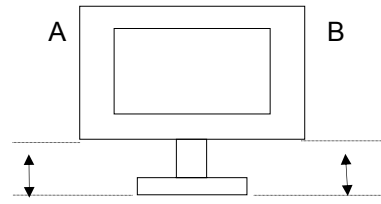

- Black side and cut side :

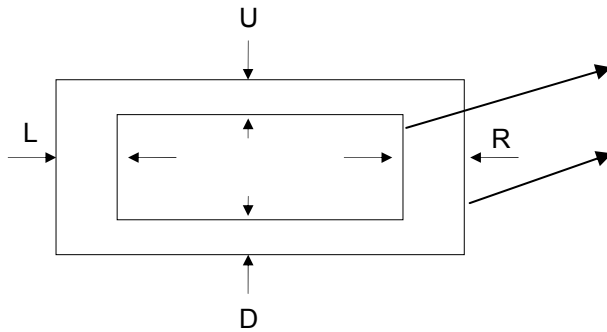

1. Visual area
H: $| L-R | \leq 0.8\sim 1.0 \text{ mm}$
V: $| U-D | \leq 0.8\sim 1.0 \text{ mm}$
2. Black side on the left and right is symmetrical, not cut side.

- Gap between bezel and rear cover $\leq 0.4\text{mm}$
- Step between bezel and rear cover
Left, right and top: $\leq 0.3\text{mm}$ Bottom and corner: $\leq 0.5\text{mm}$
- "Wobble", "Twist", etc (front to back or side to side)

Whole monitor set shall retain stability within a short time after the applied external force disappears. 20NT, 6secs (Max.) back to stable.

5.14 Kensington Lock

- Must meet Kensington_slot.spec "TYE-M0004".
- MMD request metal plate in Kensington hole.

5.15 Label

- Carton label should follow Philips requirement.
- Regulatory label follow Philips requirement.
- China RoHS label
- Detail document refer to Philips Engineering Reference Book.

5.16 Product dimension / Weight (Refer to Philips approved SHT 191/SHT560)

- Unit dimension : 442 (w)*340(H)*191(D)
- Packed unit dimension : 520(w)*352(D)*133(H)
- Net weight : 3.61
- Gross weight : 4.34

5.17 Transportation

Transportation standards refer to UAN-D1534/00/01.

5.17.1 Transportation packages

Packaging and wrapping shall be sufficient to protect the product against damage or loss during shipment from the supplier to the destination specified in the purchase order. All packing materials are subject to test and evaluation per TPV standard. The cushion material shall be constructed using EPS material.

5.17.2 Transportation Test

- Package test
 1. Random Vibration test
 2. Drop test
 3. Cold Drop test (for design reference)
- Un-package test
 1. Half sine shock test (non operation)

5.18 Pallet / Container loading

Transportation standards refer to TYE-M0002, UAN-D1534 and UAW-0309.

- Air shipment -
- Sea container 20'(pallet/slip sheet)
- Sea container 40'(pallet/slip sheet)
- Sea container 40' High Cube (pallet/slip sheet)
- Land 45' Truck and Trailer (800X1200mm pallet)
- Land 45' Truck and Trailer (1000X1200mm pallet) for UK
- Truck shipment-

Transportation request for all regions except China/India

- A. Air shipment
- B. 20'/40'/40'HQ Container loading for WW

Transportation request for China and India

- A. Container loading for China and India
- B. Truck loading

Transportation request for EU

- A. Land 45' Truck and Trailer (800X1200mm pallet)
- B. Land 45' Truck and Trailer (1000X1200mm pallet) for UK

6. Environmental Characteristics

The following sections define the interference and susceptibility condition limits that might occur between external environment and the display device.

6.1 Susceptibility of display to external environment

Operating

- Temperature: 0 to 40 degree C
- Humidity: 20 ~ 90% max
- Altitude: 0-10000 ft
- Air pressure: 600-1100 mBAR

Storage

- Temperature: -20 to 60 degree C
- Humidity: 10 ~ 90% max
- Altitude: 0- 30000ft
- Air pressure: 300-1100 mBAR

Note: recommend at 5 to 35°C, Humidity less than 60 %. Please also refer to DQE requirements

6.2 Transportation tests

Refer to 5.15.2

6.3 Display disturbances from external environment

According to IEC 801-2 for ESD disturbances

6.4 Display disturbances to external environment

7. Reliability

7.1 Mean Time between Failures

System MTBF (Including the LCD panel and CCFL): refer to 2.1 panel MTBF

8. Quality Assurance Requirements

8.1 Acceptance test

According to MIL-STD-105D Control II level

AQL: 0.4 (major)

1.5 (minor)

(Please also refer to annual quality agreement)

Customer acceptance criteria: UAW0377/00

9. Philips' Flat Panel Monitors Pixel Defect Policy

Philips' Flat Panel Monitors Pixel Defect Policy

BRIGHT DOT DEFECTS	ACCEPTABLE LEVEL
MODEL	191E2/191EL2
1 lit sub-pixel	3
2 adjacent lit sub-pixels	1
3 adjacent lit sub-pixels (one white pixel)	0
Distance between two bright dots	≥25 mm
Bright dot defects within 20 mm circle	0
Total bright dot defects of all type	3

BLACK DOT DEFECTS	ACCEPTABLE LEVEL
MODEL	191E2/191EL2
1 dark sub-pixel	5
2 adjacent dark sub-pixels	2
3 adjacent dark sub-pixels (one white pixel)	0
Distance between two black dots	≥15mm
Black dot defects within 20 mm circle*	1
Total black dot defects of all type	5

TOTAL DOT DEFECTS	ACCEPTABLE LEVEL
MODEL	191E2/191EL2
Total bright or black dot defects of all type	5

* 1 or 2 adjacent sub-pixel defects = 1 dot defect

Fig 1: Measurement Locations of Brightness Uniformity

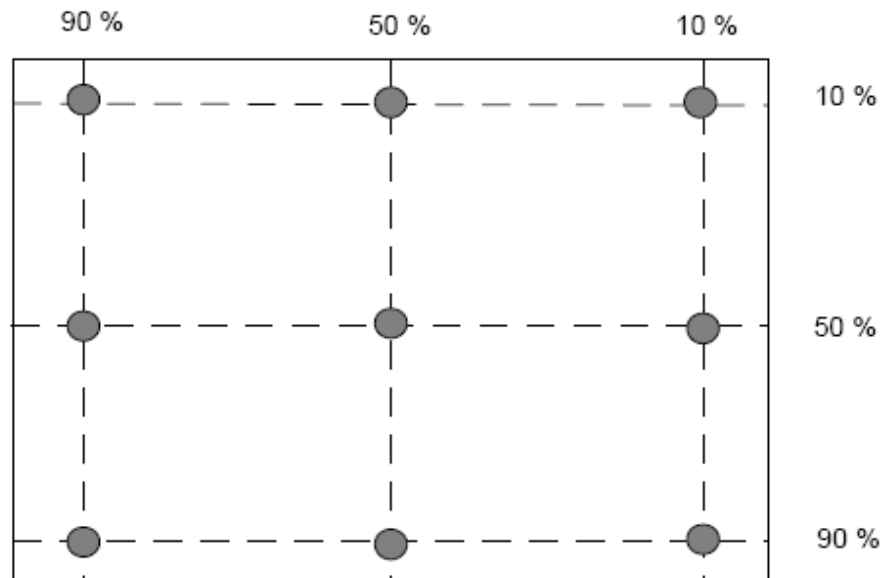

Fig 2: Cross talk pattern
Gray level 46 (64 Gray level)

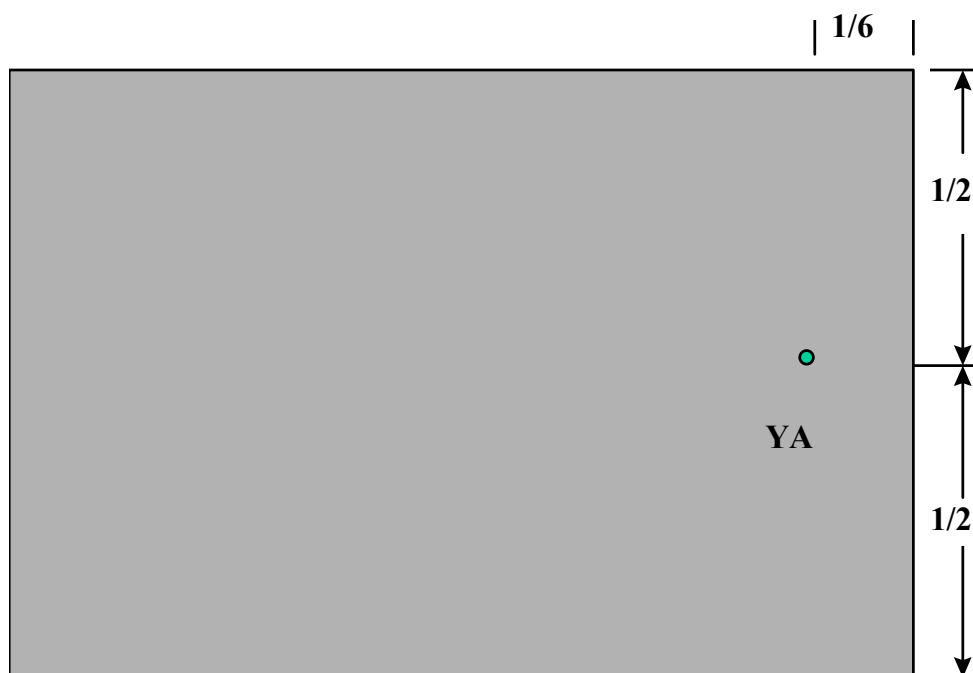
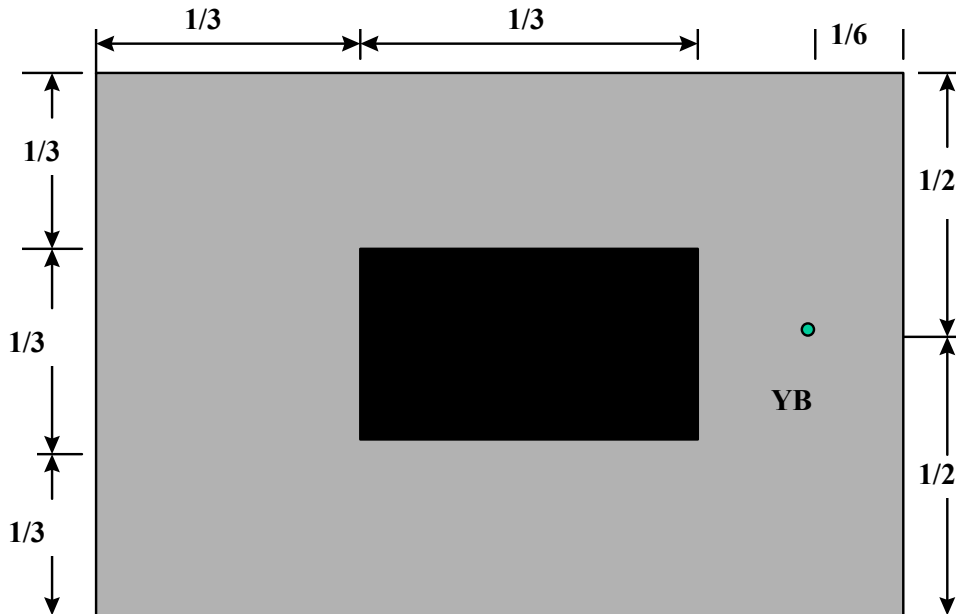

Fig 3: Cross talk Pattern
Center at Gray level 0 (Black)



10. Regulatory Compliance

10.1 Worldwide Regulatory



TYE-A0004 LCD
MNT International

10.2 EMC Requirements

Supplier DVT EMI test result must be submitted prior to DVT samples delivery, and PVT EMI test result must be submitted again prior to PVT samples delivery, which also has to meet Philips' immunity testing specification.

10.3 RoHS

Restriction on the use of certain hazardous substances.

Lead, Cadmium, Mercury, Hexavalent Chromium, Polybrominated Biphenyl (PBB) and Polybrominated Biphenyl Ether (PBDE) (flame retardant).

10.4 WEEE

Producers (Philips) responsible for retailer take back schemes and recycling.

--System implemented.

--Collection and recycle targets.

10.5 Ongoing Regulatory

There's a possibility that other regulatory certificates will be required during the life of the product. It is the responsibility of the supplier to provide related documentation.

TELEVISION/MONITOR SAFETY GUIDELINES FOR THE PROFESSIONAL SERVICE TECHNICIAN

Safety Checks

After the original service problem has been corrected, a complete safety check should be made. Be sure to check over the entire set, not just the areas where you have worked. Some previous servicer may have left an unsafe condition, which could be unknowingly passed on to your customer. Be sure to check all of the following:

Fire and Shock Hazard

1. Be sure all components are positioned in such a way as to avoid the possibility of adjacent component shorts. This is especially important on those chassis which are transported to and from the service shop.
2. Never release a repaired unit unless all protective devices such as insulators, barriers, covers, strain reliefs, and other hardware have been installed in accordance with the original design.
3. Soldering and wiring must be inspected to locate possible cold solder joints, solder splashes, sharp solder points, frayed leads, pinched leads, or damaged insulation (including the ac cord). Be certain to remove loose solder balls and all other loose foreign particles.
4. Check across-the-line components and other components for physical evidence of damage or deterioration and replace if necessary. Follow original layout, lead length, and dress.
5. No lead or component should touch a receiving tube or a resistor rated at 1 watt or more. Lead tension around protruding metal surfaces or edges must be avoided.
6. Critical components having special safety characteristics are identified with an asterisk by the Ref. No. in the parts list and enclosed within a broken line * (where several critical components are grouped in one area) along with the safety symbols on the schematic diagrams and/or exploded views.
7. When servicing any unit, always use a separate isolation transformer for the chassis. Failure to use a separate isolation transformer may expose you to possible shock hazard, and may cause damage to servicing instruments.
8. Many electronic products use a polarized ac line cord (one wide pin on the plug.) Defeating this safety feature may create a potential hazard to the service and the user. Extension cords which do not incorporate the polarizing feature should never be used.
9. After reassembly of the unit, always perform a leakage test or resistance test from the line cord to all exposed metal parts of the cabinet. Also check all metal control shafts (with knobs removed), antenna terminals, handles, screws, etc. to be sure the unit may be safely operated without danger of electrical shock.

* Broken line

Implosion

1. All picture tubes used in current model receivers are equipped with an integral implosion system. Care should always be used, and safety glasses worn, whenever handling any picture tube. Avoid scratching or otherwise damaging the picture tube during installation.
2. Use only replacement tubes specified by the manufacturer.

X-radiation

1. Be sure procedures and instructions to all your service personnel cover the subject of X-radiation. Potential sources of X-rays in TV receivers are the picture tube and the high voltage circuits. The basic precaution which must be exercised is to keep the high voltage at the factory recommended level.
2. To avoid possible exposure to X-radiation and electrical shock, only the manufacturer's specified anode connectors must be used.
3. It is essential that the service technician has an accurate HV meter available at all times. The calibration of this meter should be checked periodically against a reference standard.
4. When the HV circuitry is operating properly there is no possibility of an X-radiation problem. High voltage should always be kept at the manufacturer's rated value - no higher - for optimum performance. Every time a color set is serviced, the brightness should be run up and down while monitoring the HV with a meter to be certain that the HV is regulated correctly and does not exceed the specified value. We suggest that you and your technicians review test procedures so that HV and HV regulation are always checked as a standard servicing procedure, and the reason for this prudent routine is clearly understood by everyone. It is important to use an accurate and reliable HV meter. It is recommended that the HV recorded on each customer's invoice, which will demonstrate a proper concern for the customer's safety.
5. When troubleshooting and making test measurements in a receiver with a problem of excessive high voltage, reduce the line voltage by means of a Variac to bring the HV into acceptable limits while troubleshooting. Do not operate the chassis longer than necessary to locate the cause of the excessive HV.

6. New picture tubes are specifically designed to withstand higher operating voltages without creating undesirable X-radiation. It is strongly recommended that any shop test fixture which is to be used with the new higher voltage chassis be equipped with one of the new type tubes designed for this service. Addition of a permanently connected HV meter to the shop test fixture is advisable. The CRT types used in these new sets should never be replaced with any other types, as this may result in excessive X-radiation.
7. It is essential to use the specified picture tube to avoid a possible X-radiation problem.
8. Most TV receivers contain some type of emergency "Hold Down" circuit to prevent HV from rising to excessive levels in the presence of a failure mode. These various circuits should be understood by all technicians servicing them, especially since many hold down circuits are inoperative as long as the receiver performs normally.

Leakage Current Cold Check

1. Unplug the ac line cord and connect a jumper between the two prongs of the plug.
2. Turn on the power switch.
3. Measure the resistance value between the jumpered ac plug and all exposed cabinet parts of the receiver, such as screw heads, antennas, and control shafts. When the exposed metallic part has a return path to the chassis, the reading should be between 1 megohm and 5.2 megohms. When the exposed metal does not have a return path to the chassis, the reading must be infinity. Remove the jumper from the ac line cord.

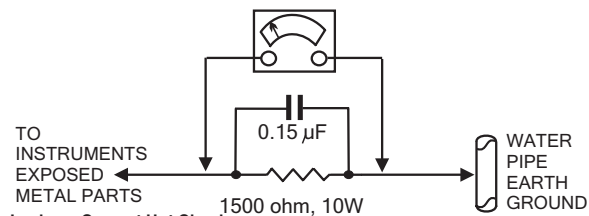
**Leakage Current Hot Check**

1. Do not use an isolation transformer for this test. Plug the completely reassembled receiver directly into the ac outlet.
2. Connect a 1.5k, 10w resistor paralleled by a 0.15uf. capacitor between each exposed metallic cabinet part and a good earth ground such as a water pipe, as shown above.
3. Use an ac voltmeter with at least 5000 ohms volt sensitivity to measure the potential across the resistor.
4. The potential at any point should not exceed 0.75 volts. A leakage current tester may be used to make this test; leakage current must not exceed 0.5 milliamps. If a measurement is outside of the specified limits, there is a possibility of shock hazard. The receiver should be repaired and rechecked before returning it to the customer.
5. Repeat the above procedure with the ac plug reversed. (Note: An ac adapter is necessary when a polarized plug is used. Do not defeat the polarizing feature of the plug.)

Picture Tube Replacement

The primary source of X-radiation in this television receiver is the picture tube. The picture tube utilized in this chassis is specially constructed to limit X-radiation emissions. For continued X-radiation protection, the replacement tube must be the same type as the original, including suffix letter, or a Philips approved type.

Parts Replacement

Many electrical and mechanical parts in Philips television sets have special safety related characteristics. These characteristics are often not evident from visual inspection nor can the protection afforded by them necessarily be obtained by using replacement components rated for higher voltage, wattage, etc. The use of a substitute part which does not have the same safety characteristics as the Philips recommended replacement part shown in this service manual may create shock, fire, or other hazards.

WARNING: Before removing the CRT anode cap, turn the unit **OFF** and short the HIGH VOLTAGE to the CRT DAG ground.
SERVICE NOTE: The CRT DAG is not at chassis ground.