

Scaler Schematic Diagram - 1

PHILIPS

All rights reserved. Reproduction in whole or in parts is prohibited without the written consent of the copyright owner.

A SCALER BOARD
 SB: 61612 x 6
 PB: 61622

Ref Des	Reserved
2226	223886715129 12p
2228	223886715129 12p
2230	223886715129 12p
2241	223878615649 100n
3242	232270296001
3244	232270296001
7241-1	935260739118
7241-2	74LVC14APW
7241-3	935260739118
7241-4	935260739118
7241-5	935260739118
7241-6	935260739118

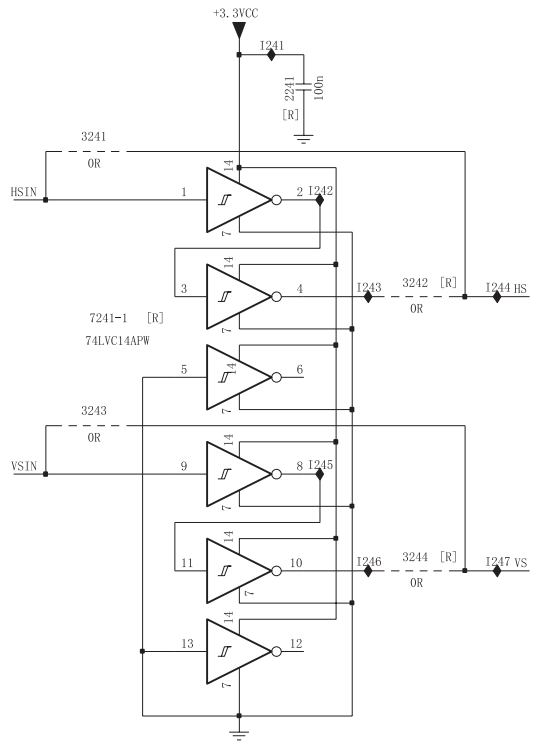
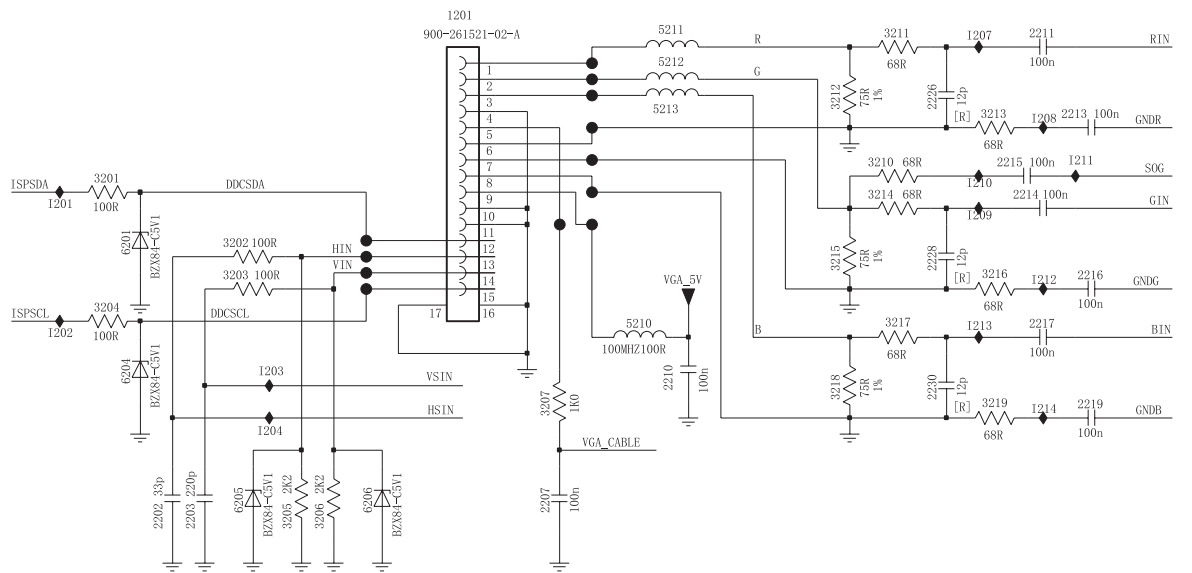

- 1201 C4
- 2202 E3
- 2203 E3
- 2207 E4
- 2210 E5
- 2211 C6
- 2213 C7
- 2214 D6
- 2215 D6
- 2216 D7
- 2217 D6
- 2219 E7
- 2226 C6
- 2228 D6
- 2230 E6
- 2241 C8
- 3201 D2
- 3202 D3
- 3203 D3
- 3204 D2
- 3205 E3
- 3206 E3
- 3207 E4
- 3210 D6
- 3211 C6
- 3212 C6
- 3213 C6
- 3214 D6
- 3215 D6
- 3216 D6
- 3217 D6
- 3218 E6
- 3219 E6
- 3241 C8
- 3242 C9
- 3243 D8
- 3244 E9
- 5210 D5
- 5211 C5
- 5212 C5
- 5213 C5
- 6201 D2
- 6204 E2
- 6205 E3
- 6206 E3
- 7241-1 D8
- 1201 D2
- 1202 D2
- 1203 E3
- 1204 E3
- 1207 C6
- 1208 C6
- 1209 D6
- 1210 D6
- 1211 D7
- 1212 D6
- 1213 D6
- 1214 E6
- 1241 B8
- 1242 C9
- 1243 C9
- 1244 C9
- 1245 D9
- 1246 E9
- 1247 E9

EXCEPT 1201 WERE CHIP COMPONENTS.

CHN	CA-	SETNAME	LCD SH6
CLASS_No		DSUB	
		170C6FS/00	
2005-04-22	3		3138 158 6427
NAME	Peter V./Stella Fann	SUPERS.	4
TY		CHECK	
		DATE	2005-04-22
			ROYAL PHILIPS ELECTRONICS N.V. 2005

Scaler Schematic Diagram - 2

PHILIPS

All rights reserved. Reproduction in whole or in parts is prohibited without the written consent of the copyright owner.

B SCALER BOARD
 SB: 61612 x 6
 PB: 61622

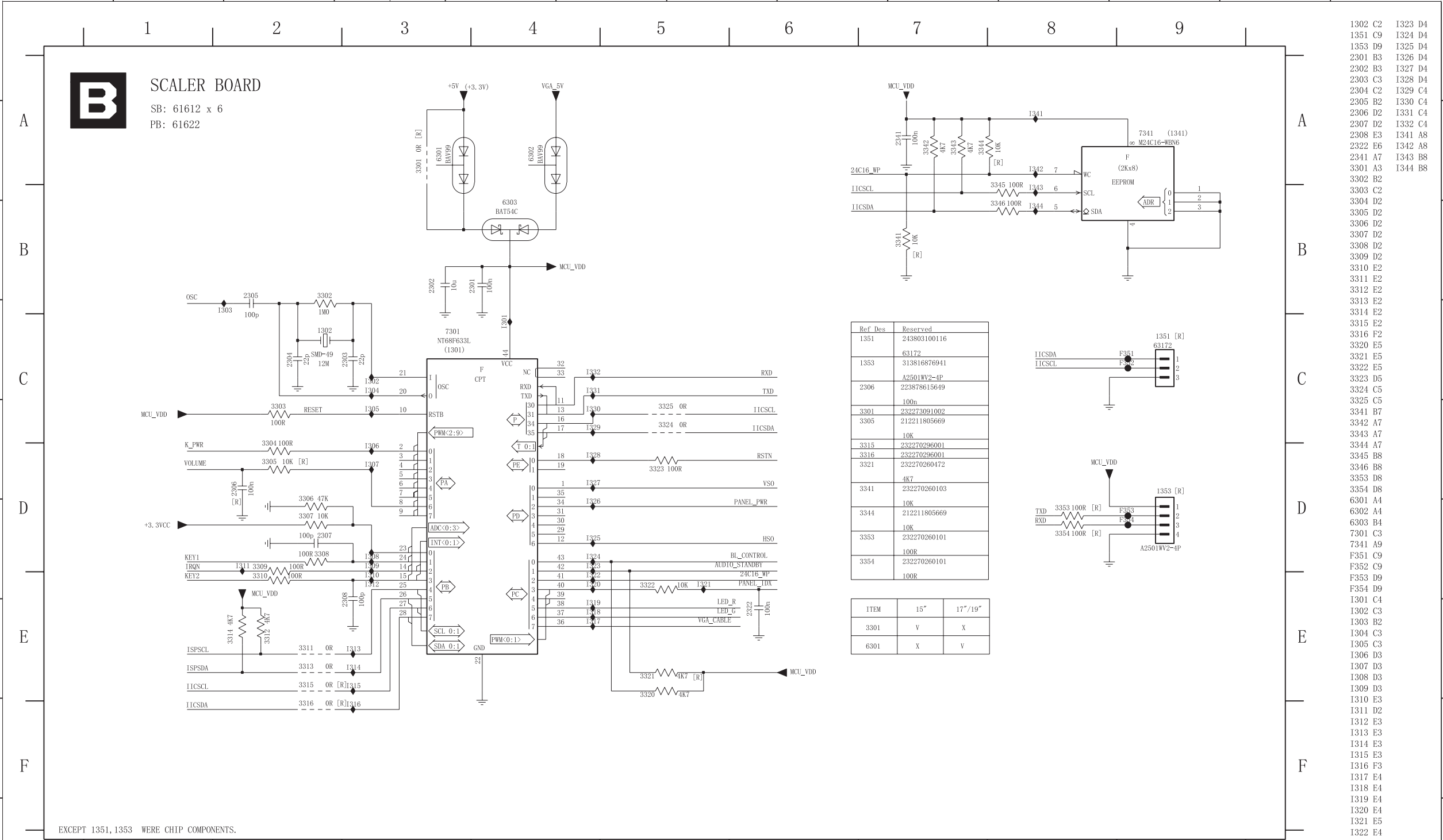

EXCEPT 1351, 1353 WERE CHIP COMPONENTS.

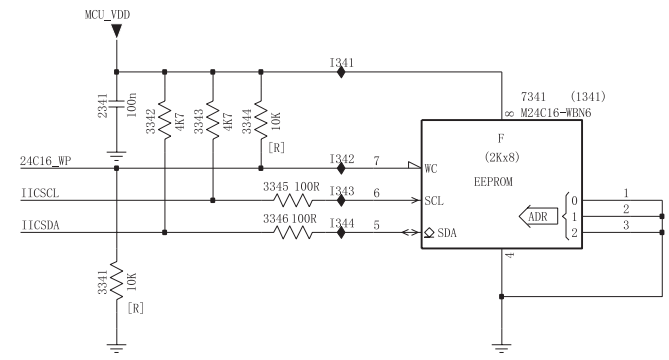

Ref Des	Reserved
1351	243803100116
	63172
1353	313816876941
	A2501WV2-4P
2306	223878615649
	100n
3301	232273091002
3305	212211805669
	10K
3315	232270296001
3316	232270296001
3321	232270260472
	4K7
3341	232270260103
	10K
3344	212211805669
	10K
3353	232270260101
	100R
3354	232270260101
	100R

ITEM	15"	17"/19"
3301	V	X
6301	X	V

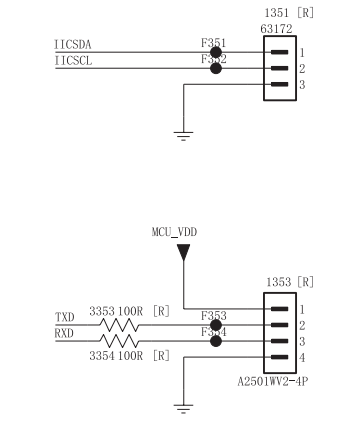

- 1302 C2
- 1351 C9
- 1353 D9
- 2301 B3
- 2302 B3
- 2303 C3
- 2304 C2
- 2305 B2
- 2306 D2
- 2307 D2
- 2308 E3
- 2341 A7
- 3301 A3
- 3302 B2
- 3303 C2
- 3304 D2
- 3305 D2
- 3306 D2
- 3307 D2
- 3308 D2
- 3309 D2
- 3310 E2
- 3311 E2
- 3312 E2
- 3313 E2
- 3314 E2
- 3315 E2
- 3316 F2
- 3320 E5
- 3321 E5
- 3322 E5
- 3323 D5
- 3324 C5
- 3325 C5
- 3341 B7
- 3342 A7
- 3343 A7
- 3345 B8
- 3346 B8
- 3353 D8
- 3354 D8
- 6301 A4
- 6302 A4
- 6303 B4
- 7301 C3
- 7341 A9
- F351 C9
- F352 C9
- F353 D9
- F354 D9
- I301 C4
- I302 C3
- I303 B2
- I304 C3
- I305 C3
- I306 D3
- I307 D3
- I308 D3
- I309 D3
- I310 E3
- I311 D2
- I312 E3
- I313 E3
- I314 E3
- I315 E3
- I316 F3
- I317 E4
- I318 E4
- I319 E4
- I320 E4
- I321 E5
- I322 E4
- I323 D4
- I324 D4
- I325 D4
- I326 D4
- I327 D4
- I328 D4
- I329 D4
- I330 C4
- I331 C4
- I332 C4
- I341 A8
- I342 A8
- I343 B8
- I344 B8

CHN	CA-	SETNAME	LCD SH6
CLASS_NO	MICRO		1
	170C6FS/00		3138 158 6427
2005-04-22	3		
NAME	Peter V./Stella Fann	SUPERS.	4
TY	CHECK	DATE	2005-04-22
			130 - 2
			ROYAL PHILIPS ELECTRONICS N.V. 2005

Scaler Schematic Diagram - 3

PHILIPS

SCALER BOARD
 SB: 61612 x 6
 PB: 61622

All rights reserved. Reproduction in whole or in parts is prohibited without the written consent of the copyright owner.

Alle rechten voorbehouden. Vervielfoudiging, geheel of gedeeltelijk, is niet toegestaan dan met schriftelijke toestemming van de auteursrechtbehoudende.

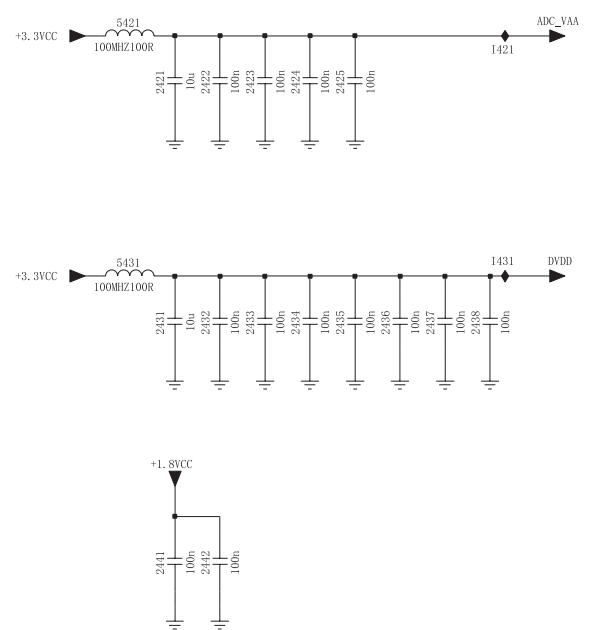

Ref Des	Reserved
1452	24220250567 60947
1453	jrc62430l-30p 62430
2411	222224119876 10u
3451	232270296001
3452	232270296001
3461	232270296001

ITEM	15"	17"/19"
1451/1453	X	V
1452	V	X
3411	X	V
3412	X	V

EXCEPT 2415 WERE CHIP COMPONENTS.

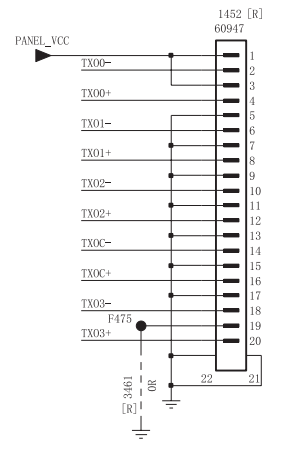
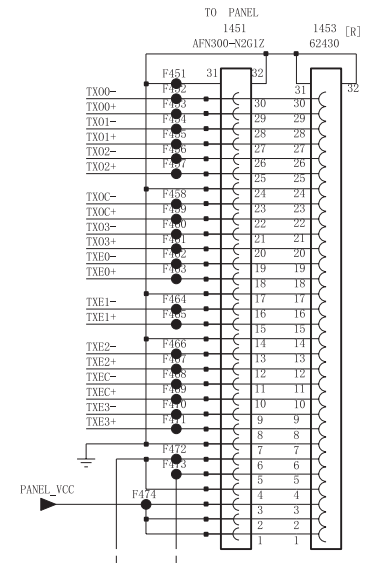
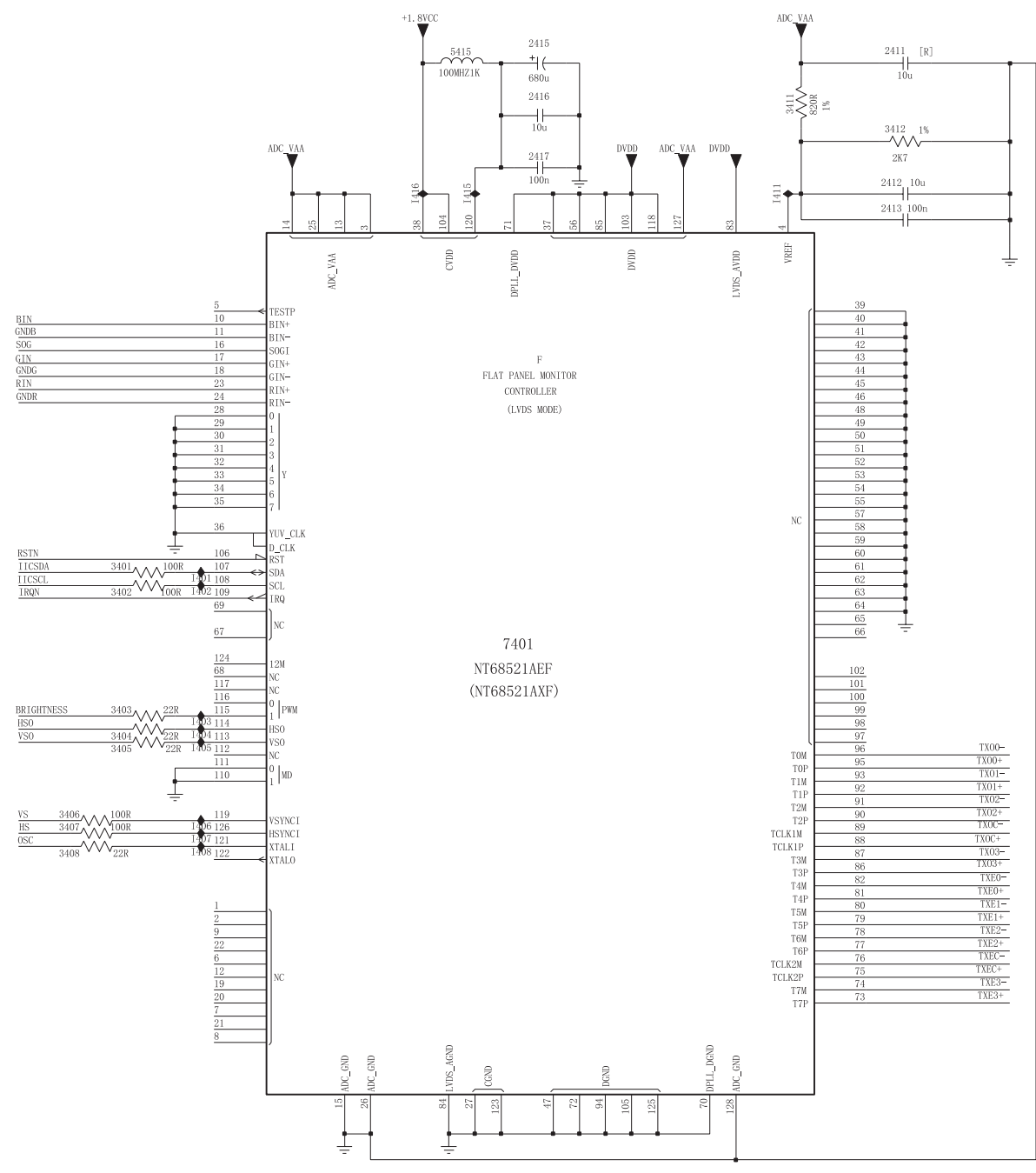

- 1451 A11
- 1452 D12
- 1453 A12
- 2411 A9
- 2412 B9
- 2413 B9
- 2415 A7
- 2416 A7
- 2417 B7
- 2421 B2
- 2422 B2
- 2423 B2
- 2424 B3
- 2425 B3
- 2431 D2
- 2432 D2
- 2433 D2
- 2434 D3
- 2435 D3
- 2436 D3
- 2437 D3
- 2438 D4
- 2441 E2
- 2442 E2
- 3401 D5
- 3402 D5
- 3403 E5
- 3404 E5
- 3405 E5
- 3406 E5
- 3407 E5
- 3408 F5
- 3411 A8
- 3412 B9
- 3451 D11
- 3452 D11
- 3461 F11
- 5415 A7
- 5421 B2
- 5431 C2
- 7401 D7
- F451 A11
- F452 A11
- F453 A11
- F454 A11
- F455 A11
- F456 B11
- F457 B11
- F458 B11
- F459 B11
- F460 B11
- F461 B11
- F462 B11
- F463 B11
- F464 B11
- F465 B11
- F466 B11
- F467 C11
- F468 C11
- F469 C11
- F470 C11
- F471 C11
- F472 C11
- F473 C11
- F474 C11
- F475 F11
- 1401 D5
- 1402 D5
- 1403 E5
- 1404 E5
- 1405 E5
- 1406 E5
- 1407 E5
- 1408 E5
- 1411 B8
- 1415 B7
- 1416 B6
- 1421 B4
- 1431 C4

CHN	CA-	SETNAME	LCD SH6
CLASS_NO		1	
Scaler		3138 158 6427	
170C6FS/00			
NAME	Peter V./Stella Fann	SUPERS.	4
TY		DATE	2005-04-22
		ROYAL PHILIPS ELECTRONICS N.V.	2005

Scaler Schematic Diagram - 4

PHILIPS

All rights reserved. Reproduction in whole or in parts is prohibited without the written consent of the copyright owner.

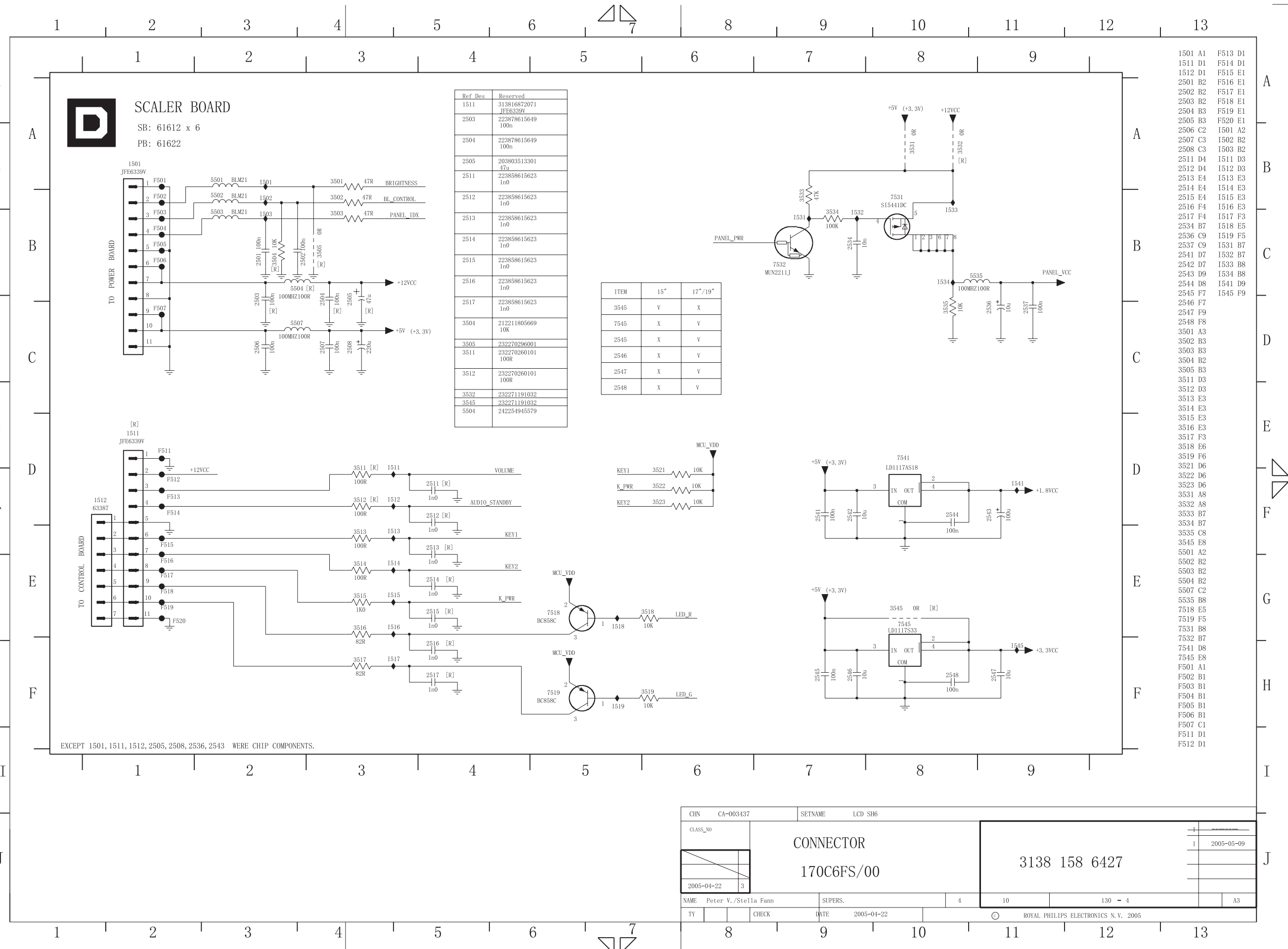

Ref Des	Reserved
1511	313816872071 JFE6339V
2503	223878615649 100n
2504	223878615649 100n
2505	203803513301 47u
2511	223858615623 1n0
2512	223858615623 1n0
2513	223858615623 1n0
2514	223858615623 1n0
2515	223858615623 1n0
2516	223858615623 1n0
2517	223858615623 1n0
3504	212211805669 10K
3505	232270296001
3511	232270260101 100R
3512	232270260101 100R
3532	232271191032
3545	232271191032
5504	242254945579

ITEM	15"	17"/19"
3545	V	X
7545	X	V
2545	X	V
2546	X	V
2547	X	V
2548	X	V

CHN	CA-003437	SETNAME	LCD SH6
CLASS_No		CONNECTOR 170C6FS/00	
		3138 158 6427	
NAME	Peter V./Stella Fann	SUPERS.	4
TY		DATE	2005-04-22
			130 - 4
			A3

EXCEPT 1501, 1511, 1512, 2505, 2508, 2536, 2543 WERE CHIP COMPONENTS.

Control Schematic Diagram & C.B.A

PHILIPS

All rights reserved. Reproduction in whole or in parts is prohibited without the written consent of the copyright owner.

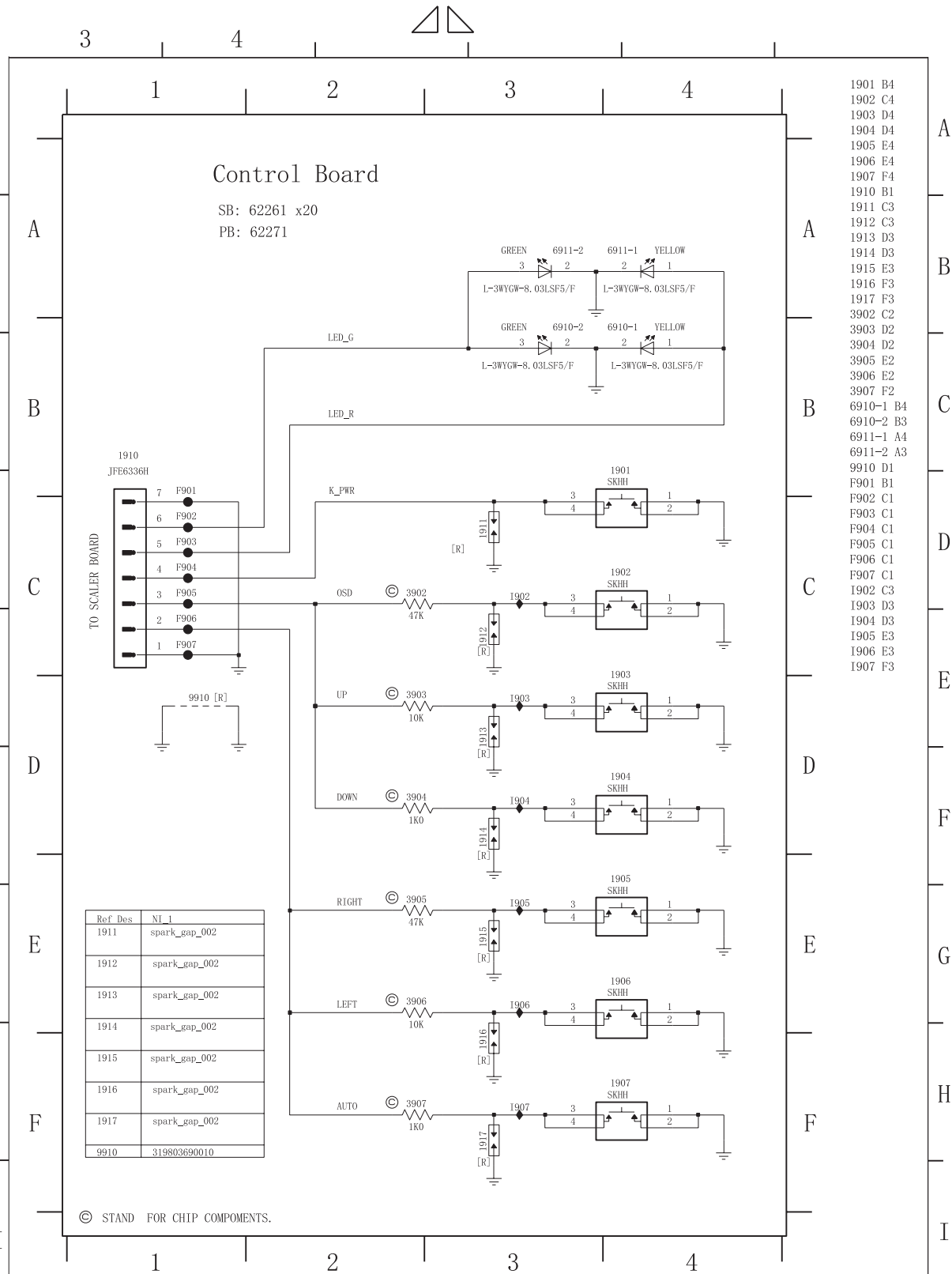

- 1901 B4
- 1902 C4
- 1903 D4
- 1904 D4
- 1905 E4
- 1906 E4
- 1907 F4
- 1910 B1
- 1911 C3
- 1912 C3
- 1913 D3
- 1914 D3
- 1915 E3
- 1916 F3
- 1917 F3
- 3902 C2
- 3903 D2
- 3904 D2
- 3905 E2
- 3906 E2
- 3907 F2
- 6910-1 B4
- 6910-2 B3
- 6911-1 A4
- 6911-2 A3
- 9910 D1
- F901 B1
- F902 C1
- F903 C1
- F904 C1
- F905 C1
- F906 C1
- F907 C1
- 1902 C3
- 1903 D3
- 1904 D3
- 1905 E3
- 1906 E3
- 1907 F3

CHN	CA-	SETNAME	LCD SH6
CLASS_NO	CONTROL BOARD		1
	170C6FS/00		3138 158 6377
NAME	Peter V./Stella Fann	SUPERS.	1
TY	CHECK	DATE	2005-04-22
		ROYAL PHILIPS ELECTRONICS N.V.	2005

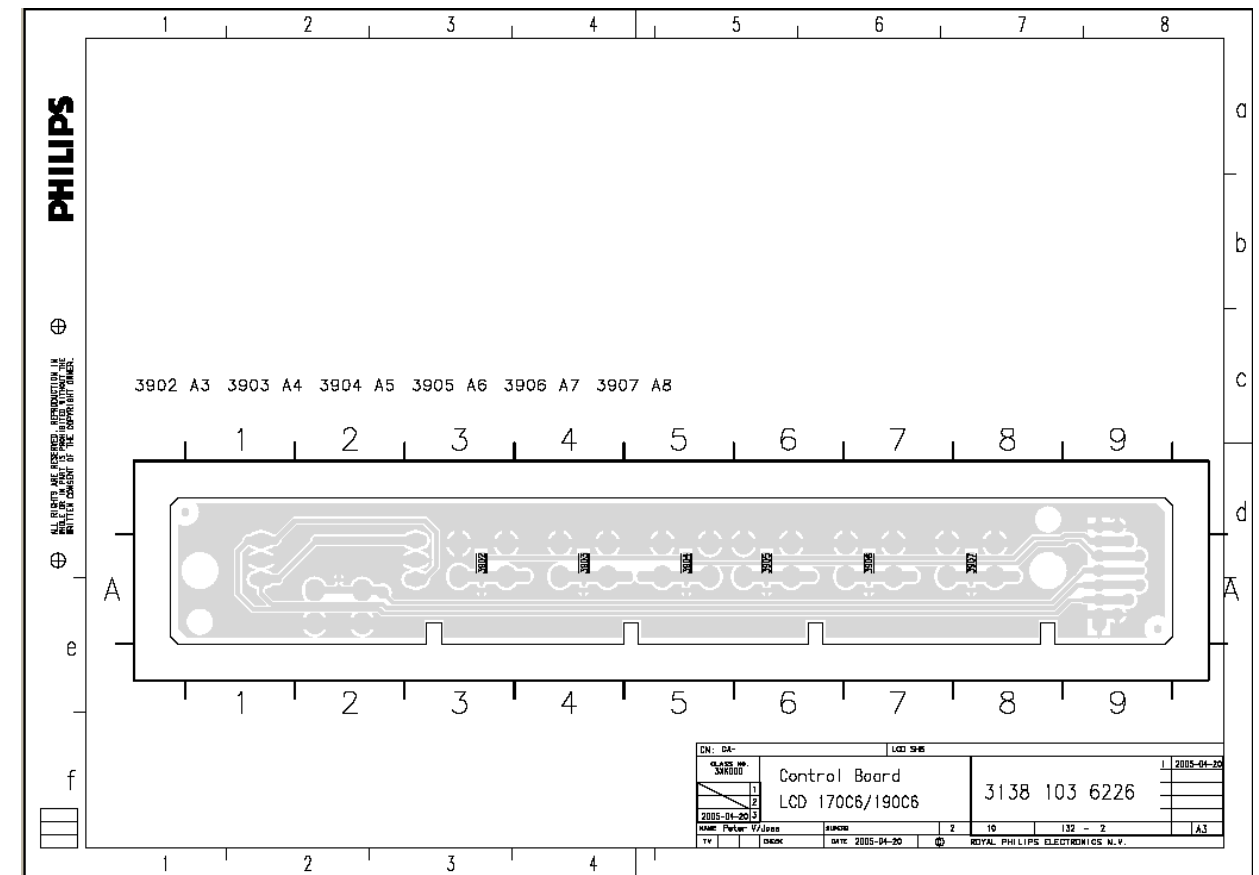
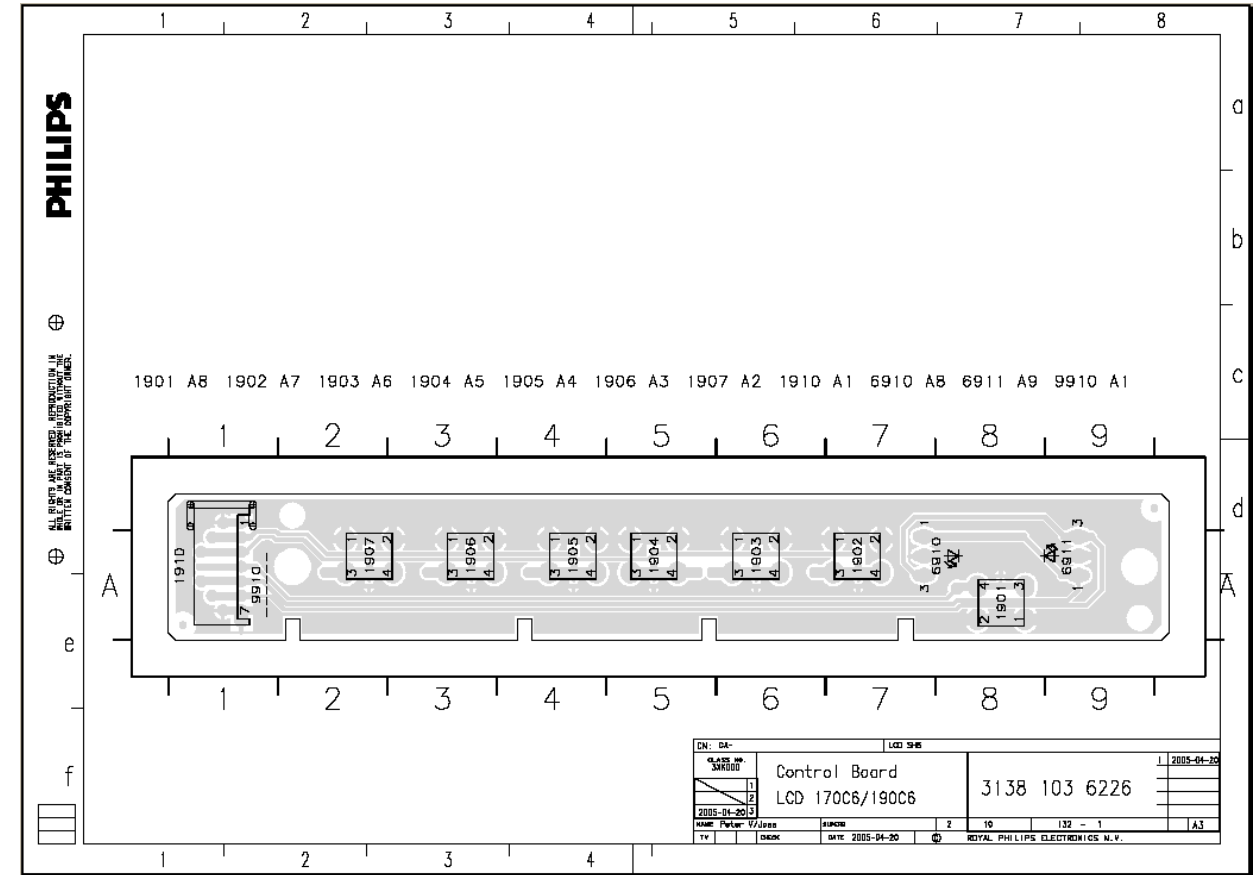

Power Board Schematic Diagram - Delta

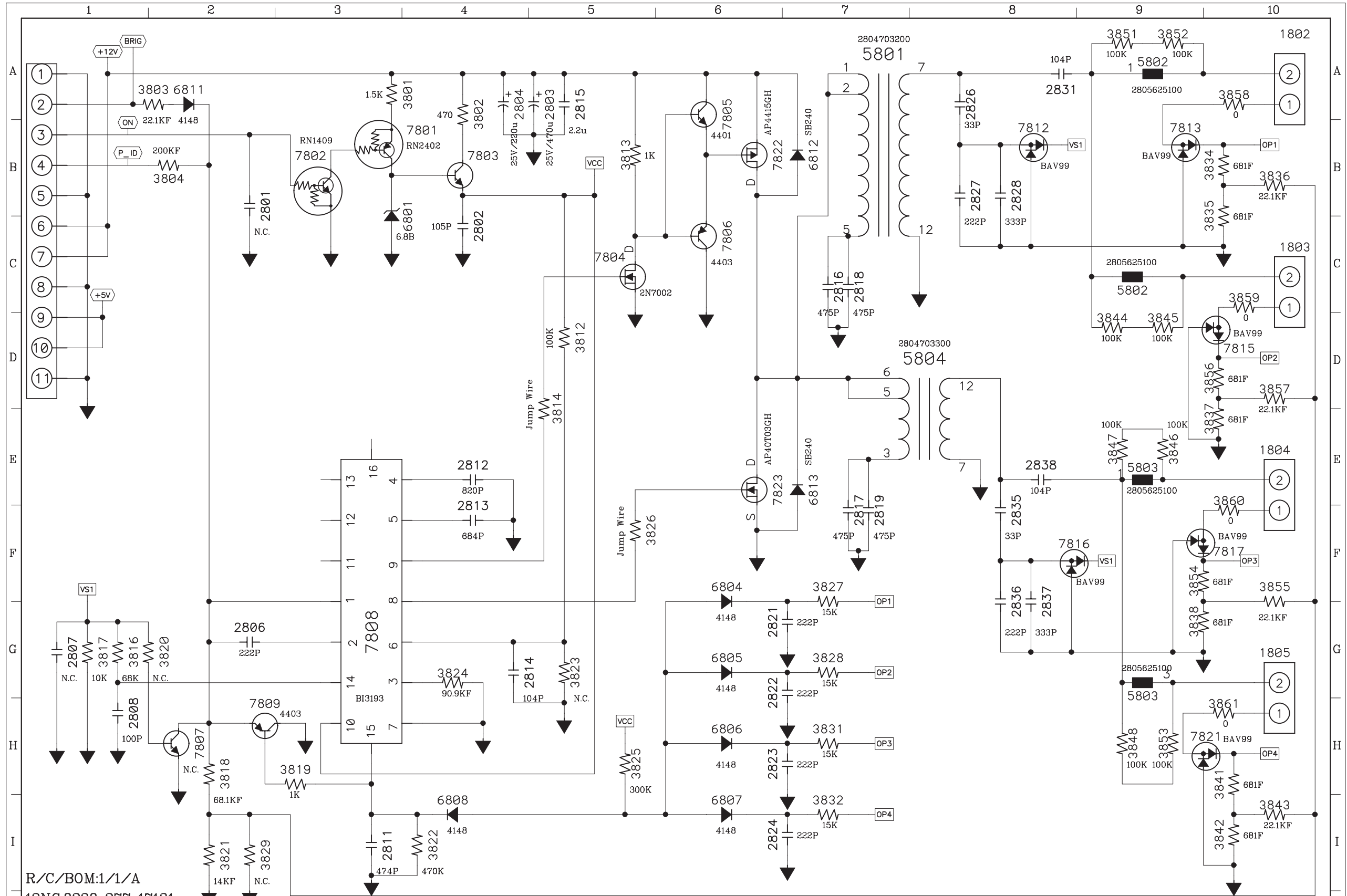

R/C/BOM:1/1/A
12NC:8238 277 17131

DELTA DELTA ELECTRONICS, INC.
THESE DRAWINGS AND SPECIFICATIONS ARE THE PROPERTY OF DELTA ELECTRONICS, INC AND SHALL NOT BE REPRODUCED OR USED AS THE BASIS FOR THE MANUFACTURE OR SELL OF APPARATUSES OR DEVICES WITHOUT PERMISSON.

Date: 12/08/04 LY.REV:(R/C) 1/0 Drawn: MAY
PWB:EADP-43AF A 2941012401 FILE NAME: SC-E43AF A
DESCRIPTION:SCHEMATIC OF AC --> DC ADAPTOR

Checked
鄭宇凱
12/08/04

Approved
江碩桓
12/08/04

PART NO.
EADP-43AF A

REV.
S00

SHEET
02 OF 02

Power Board Schematic Diagram - Lien Chang

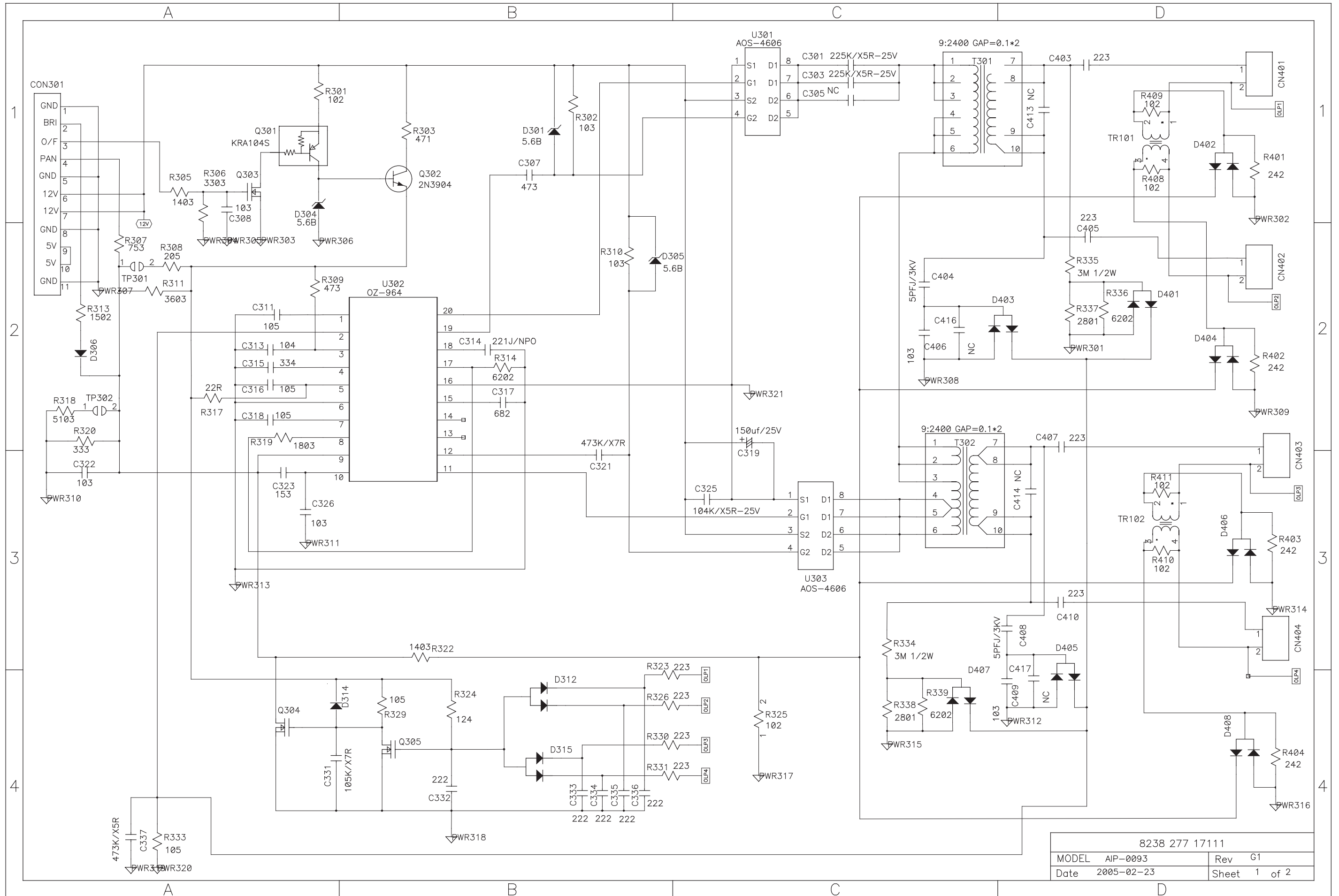

8238 277 17111			
MODEL	AIP-0093	Rev	G1
Date	2005-02-23	Sheet	1 of 2

