

BLOCK DIAGRAM (MAIN/CONTROL/INVERTER)

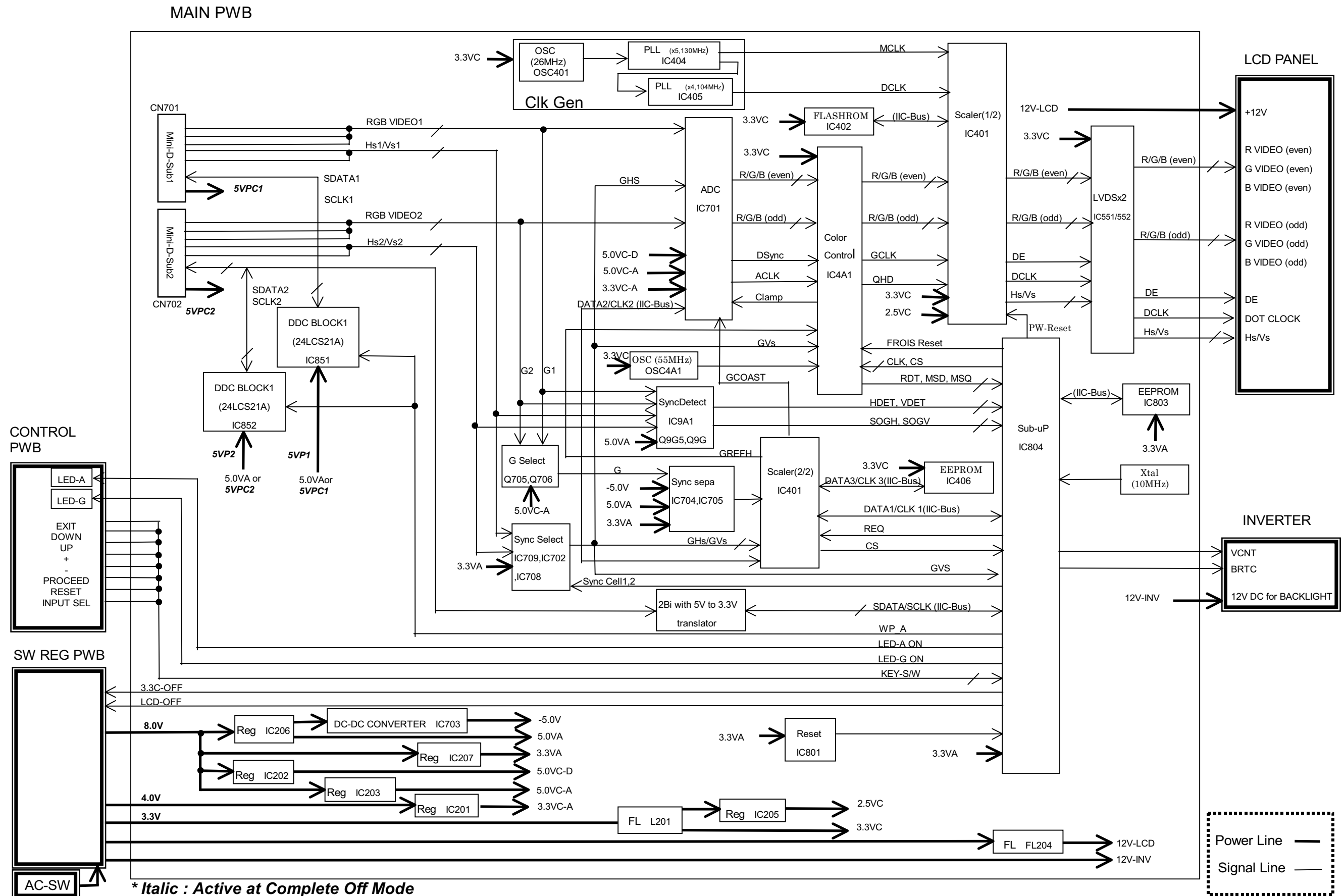

BLOCK DIAGRAM (SW REG)

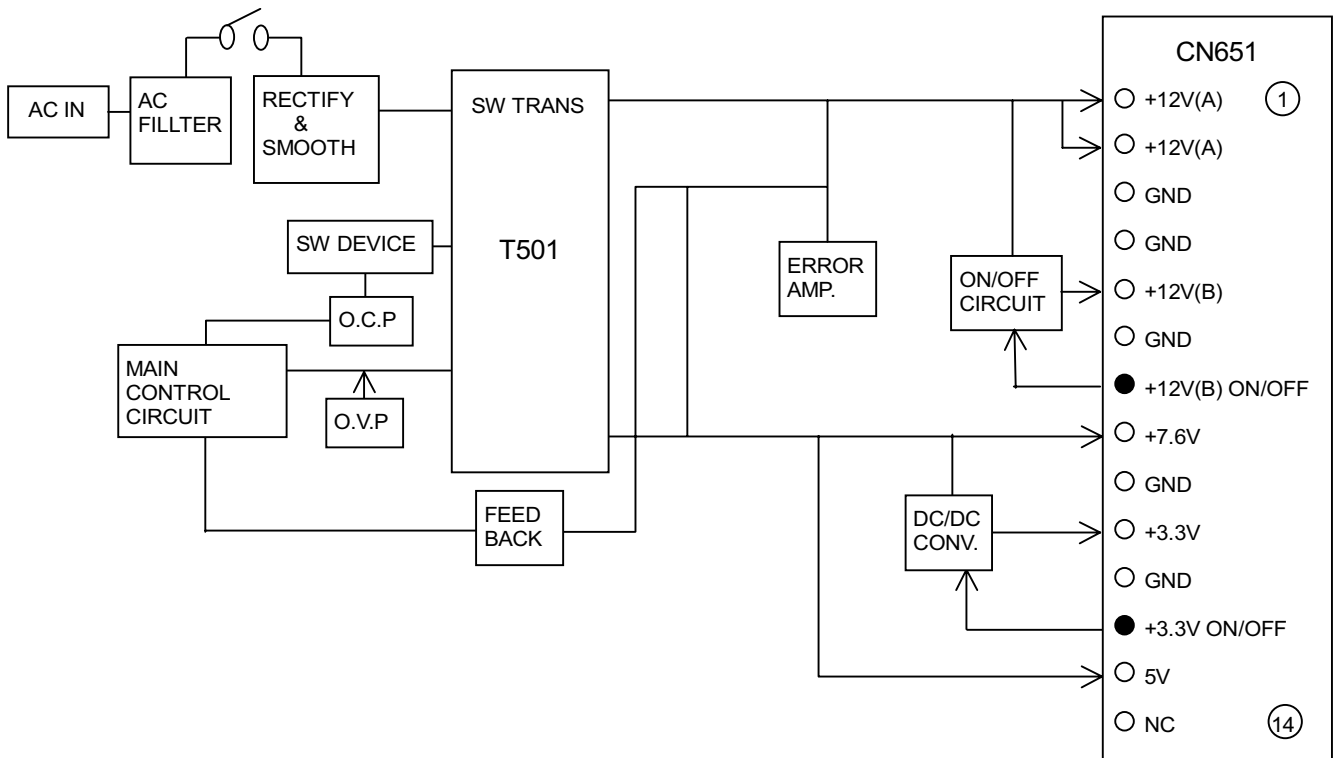

MODEL LCD1830 MAIN PWB SCHEMATIC DIAGRAM(1/8)

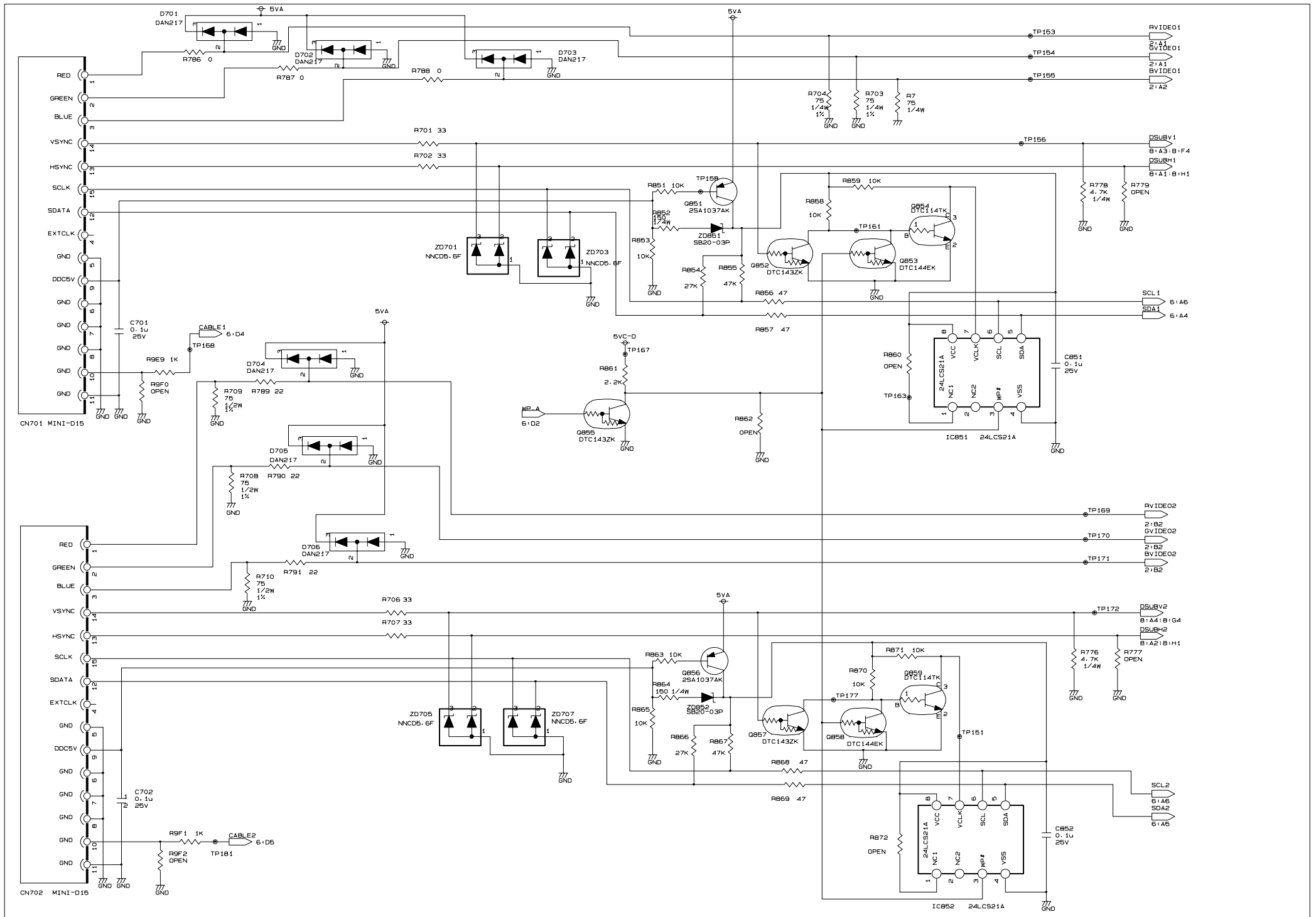

MODEL LCD1830 MAIN PWB SCHEMATIC DIAGRAM(2/8)

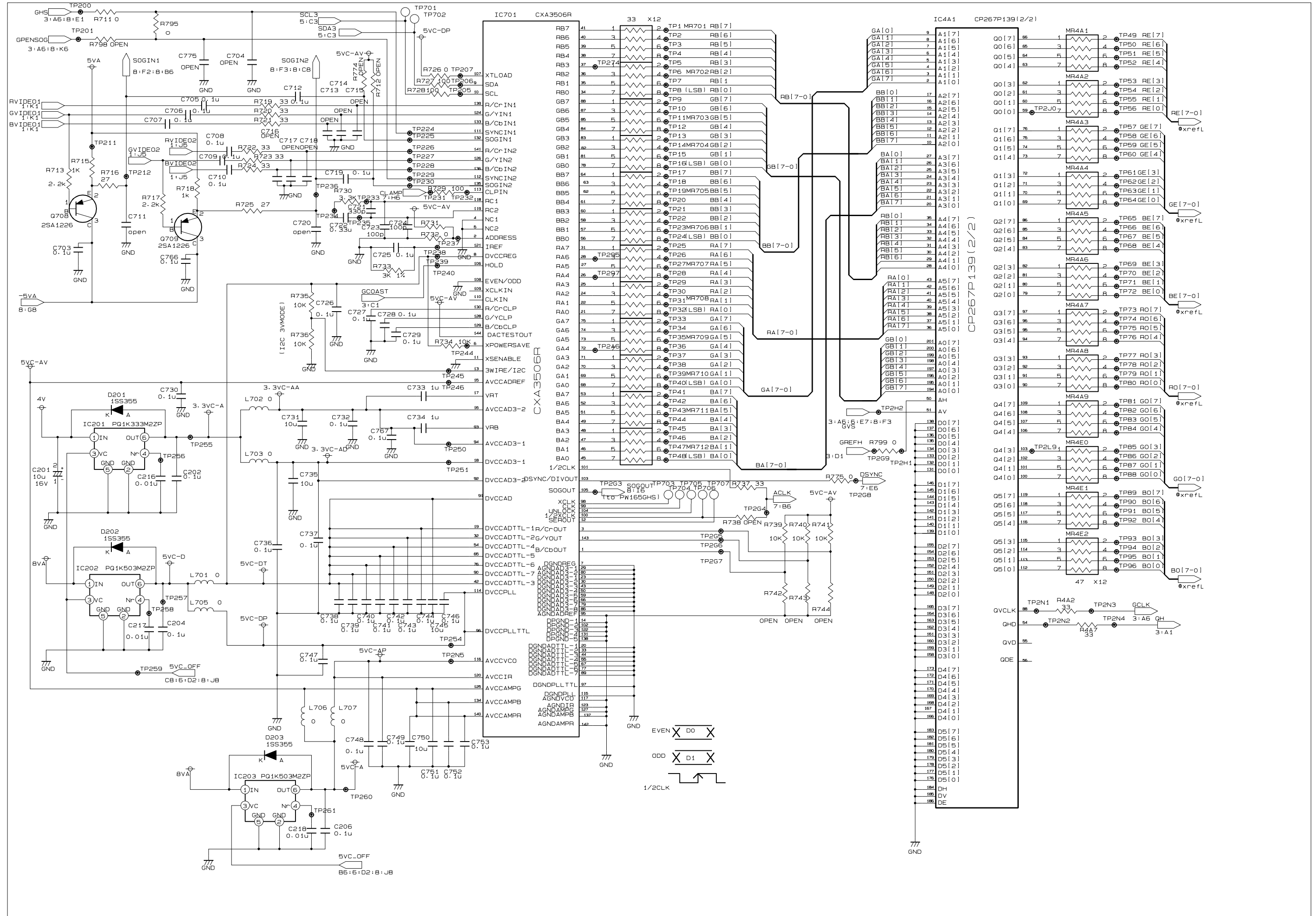

MODEL LCD1830 MAIN PWB SCHEMATIC DIAGRAM(3/8)

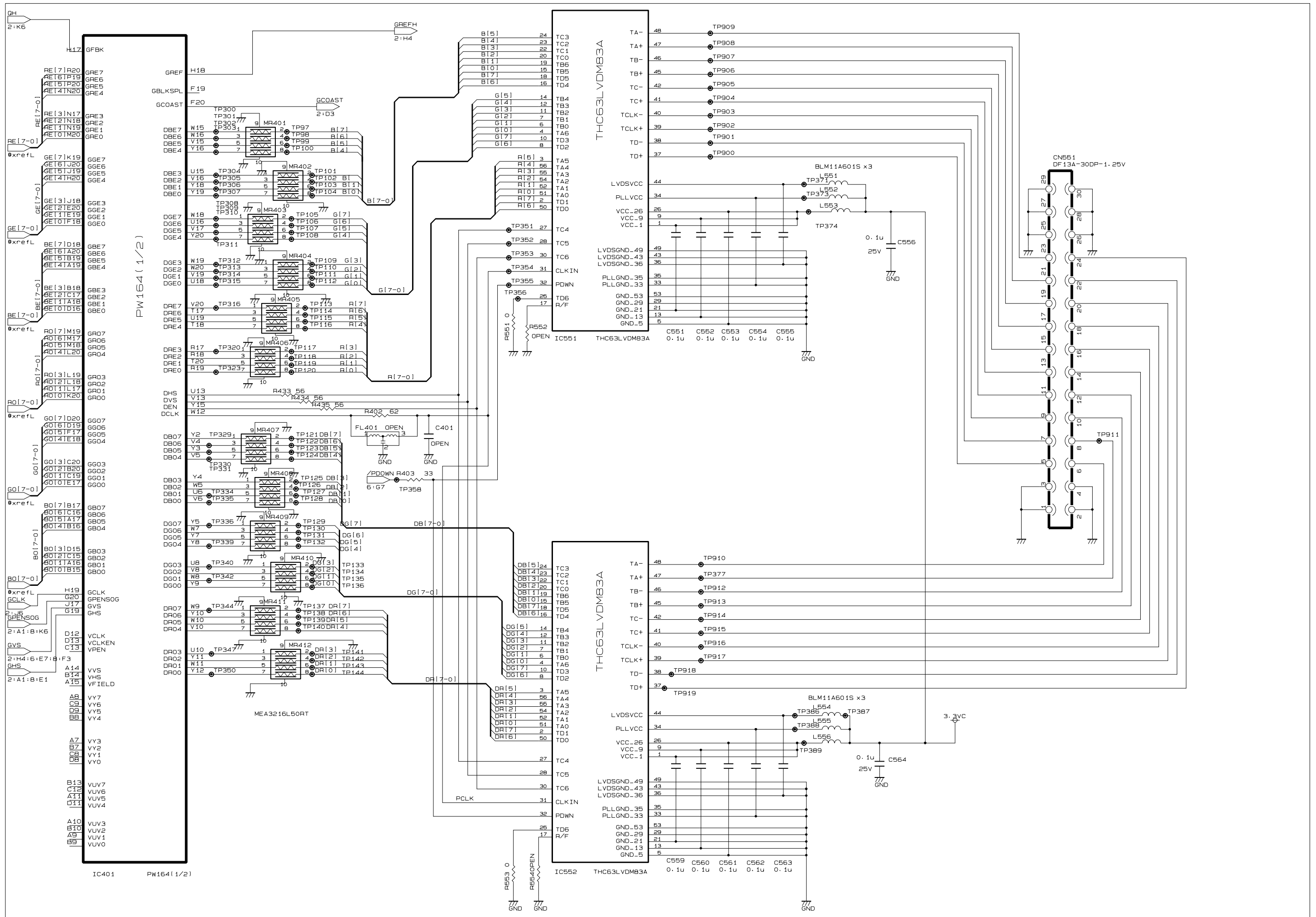

MODEL LCD1830 MAIN PWB SCHEMATIC DIAGRAM(4/8)

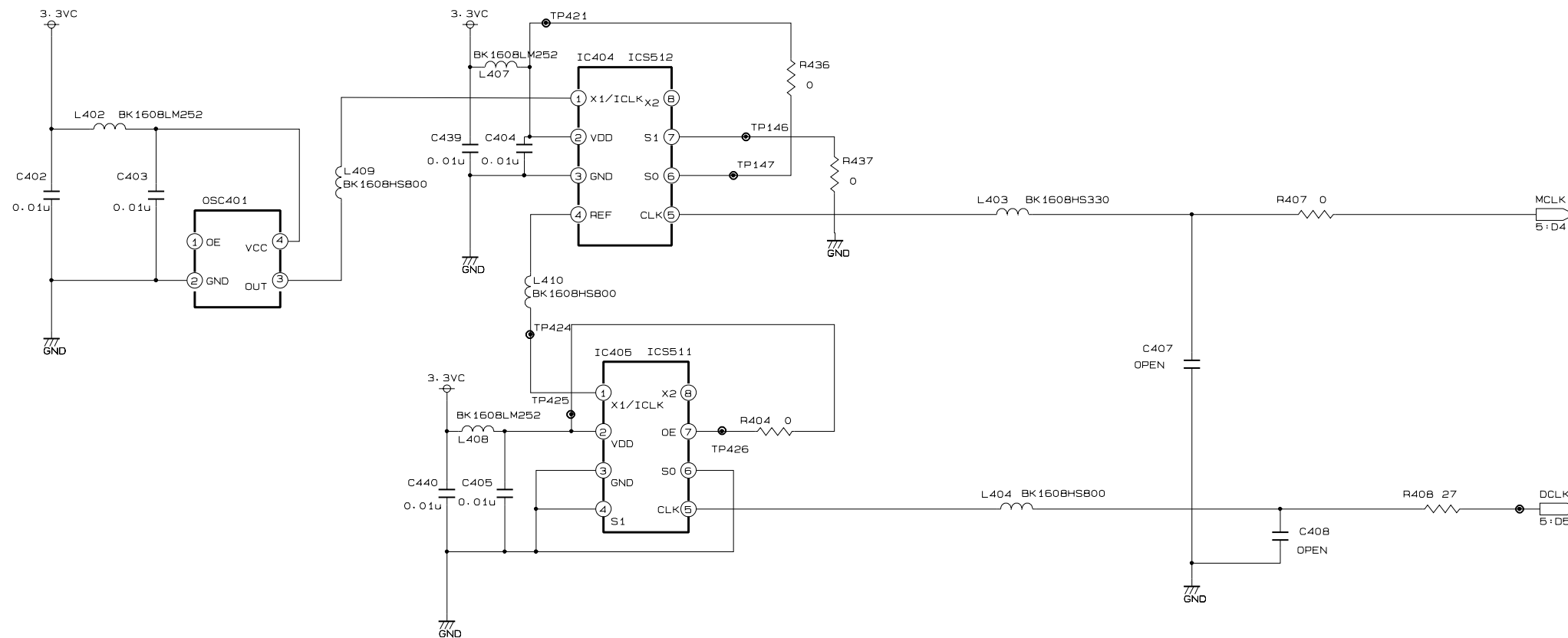
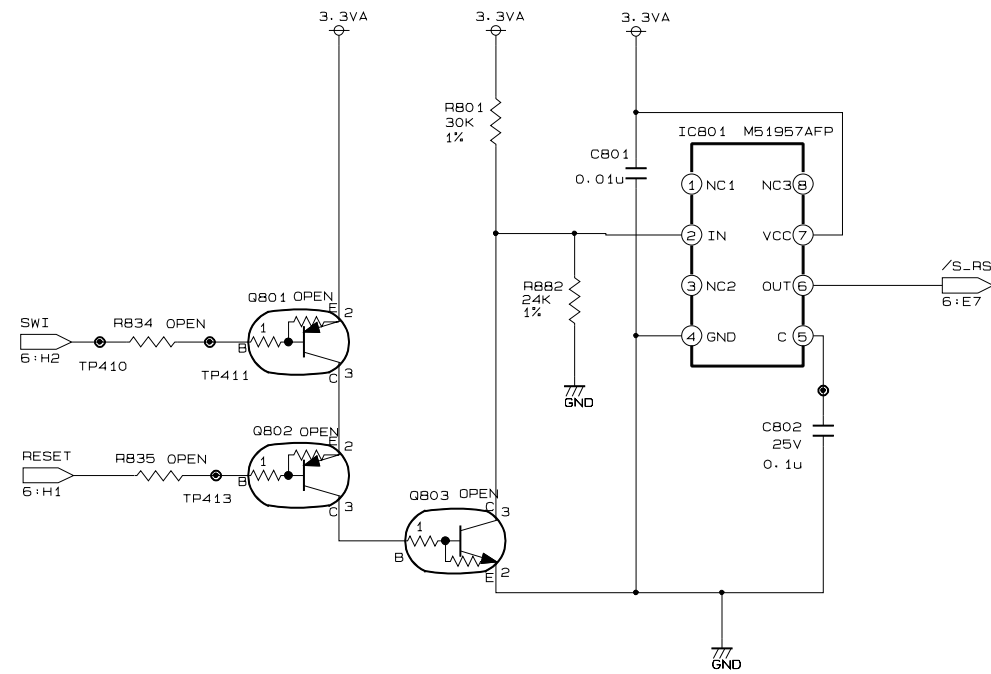

MODEL LCD1830 MAIN PWB SCHEMATIC DIAGRAM(5/8)

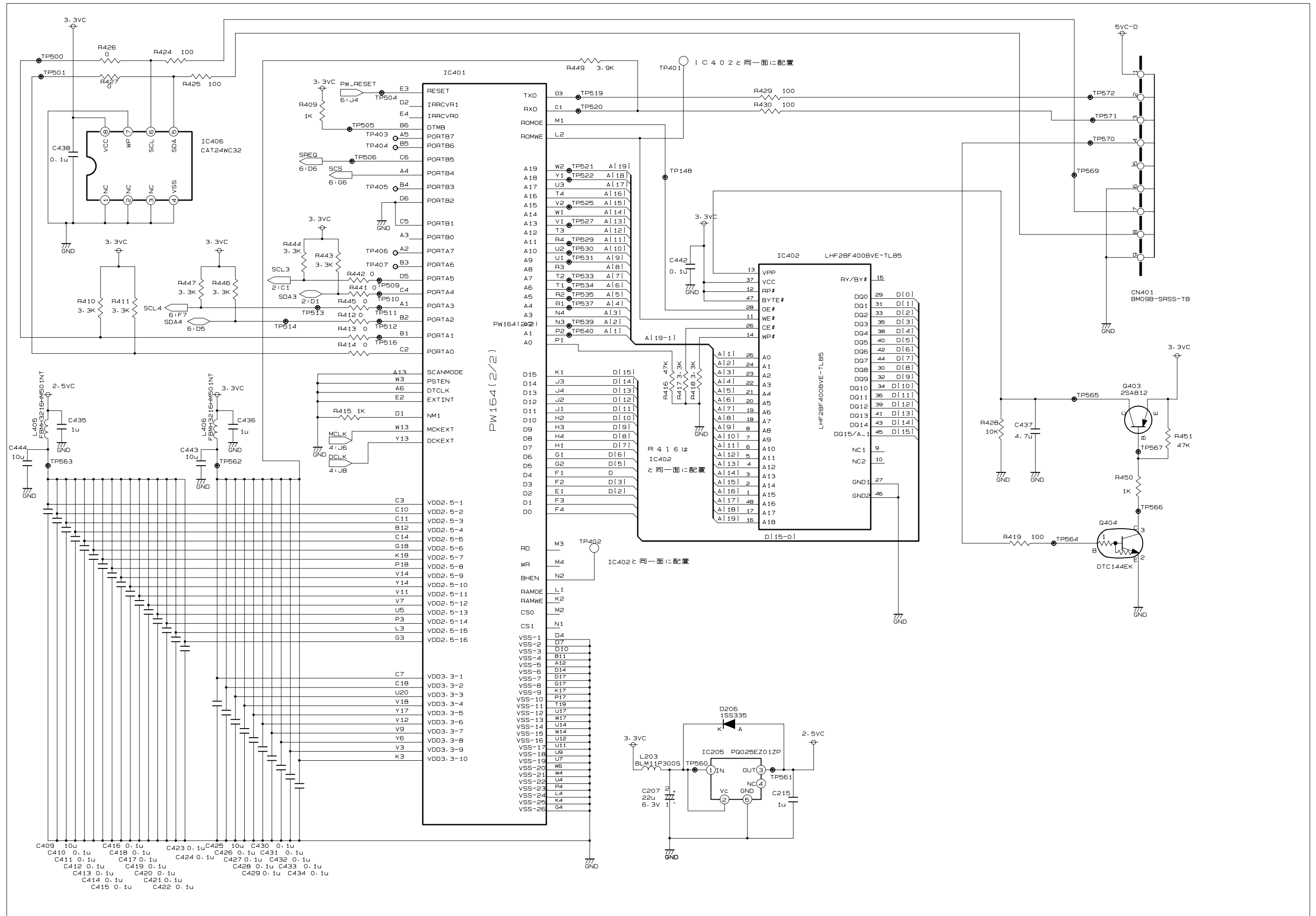

MODEL LCD1830 MAIN PWB SCHEMATIC DIAGRAM(6/8)

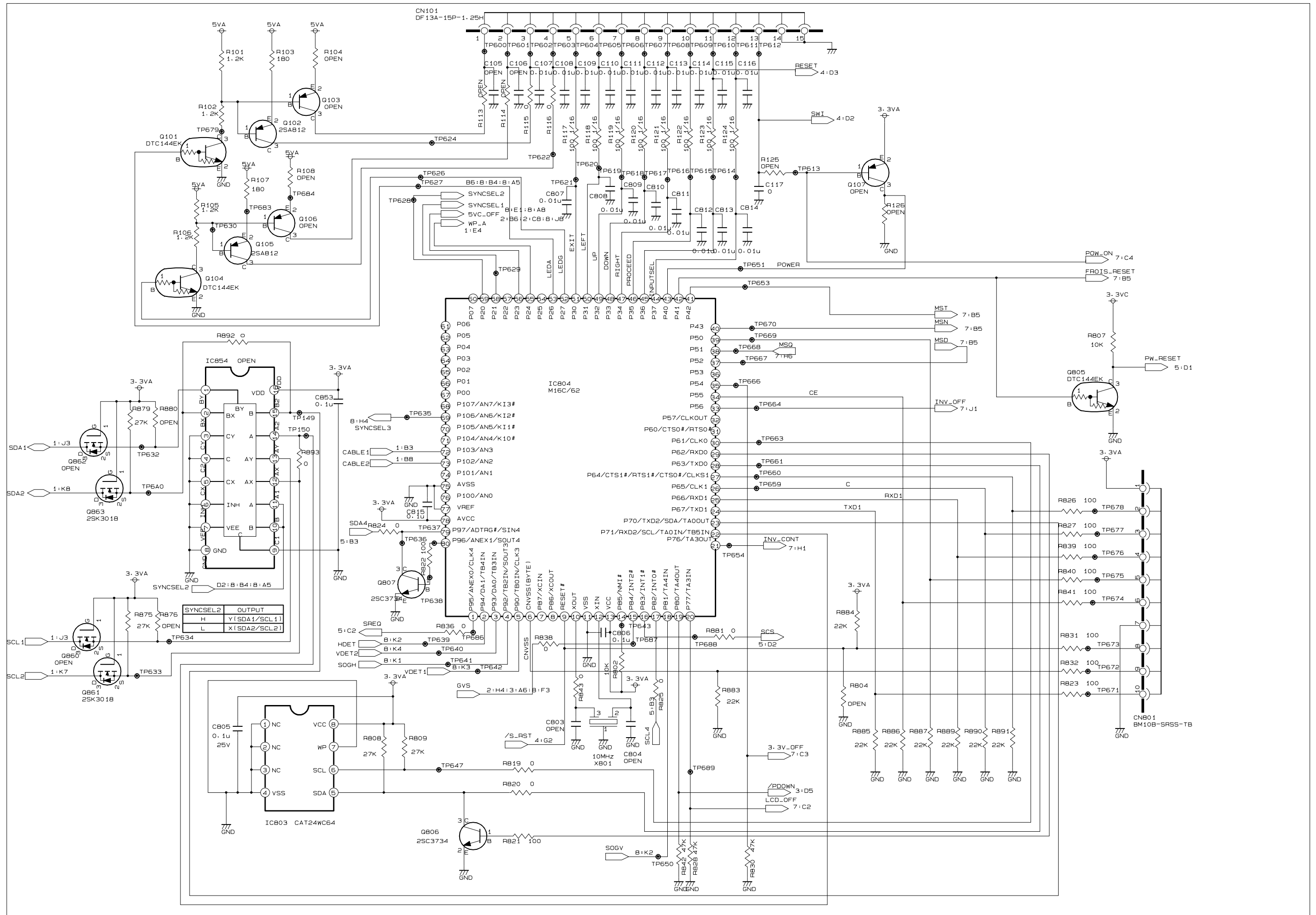

MODEL LCD1830 MAIN PWB SCHEMATIC DIAGRAM(7/8)

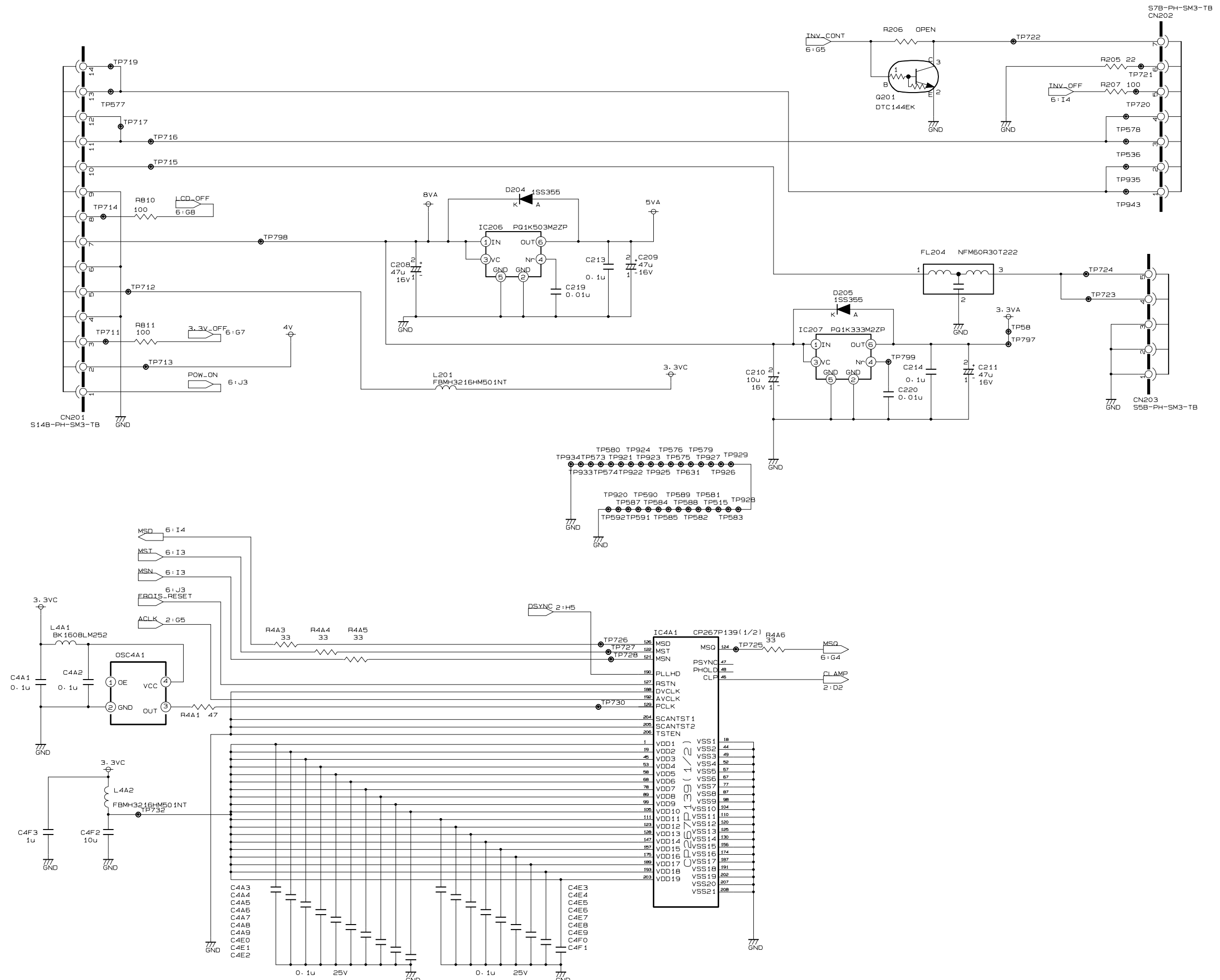

MODEL LCD1830 MAIN PWB SCHEMATIC DIAGRAM(8/8)

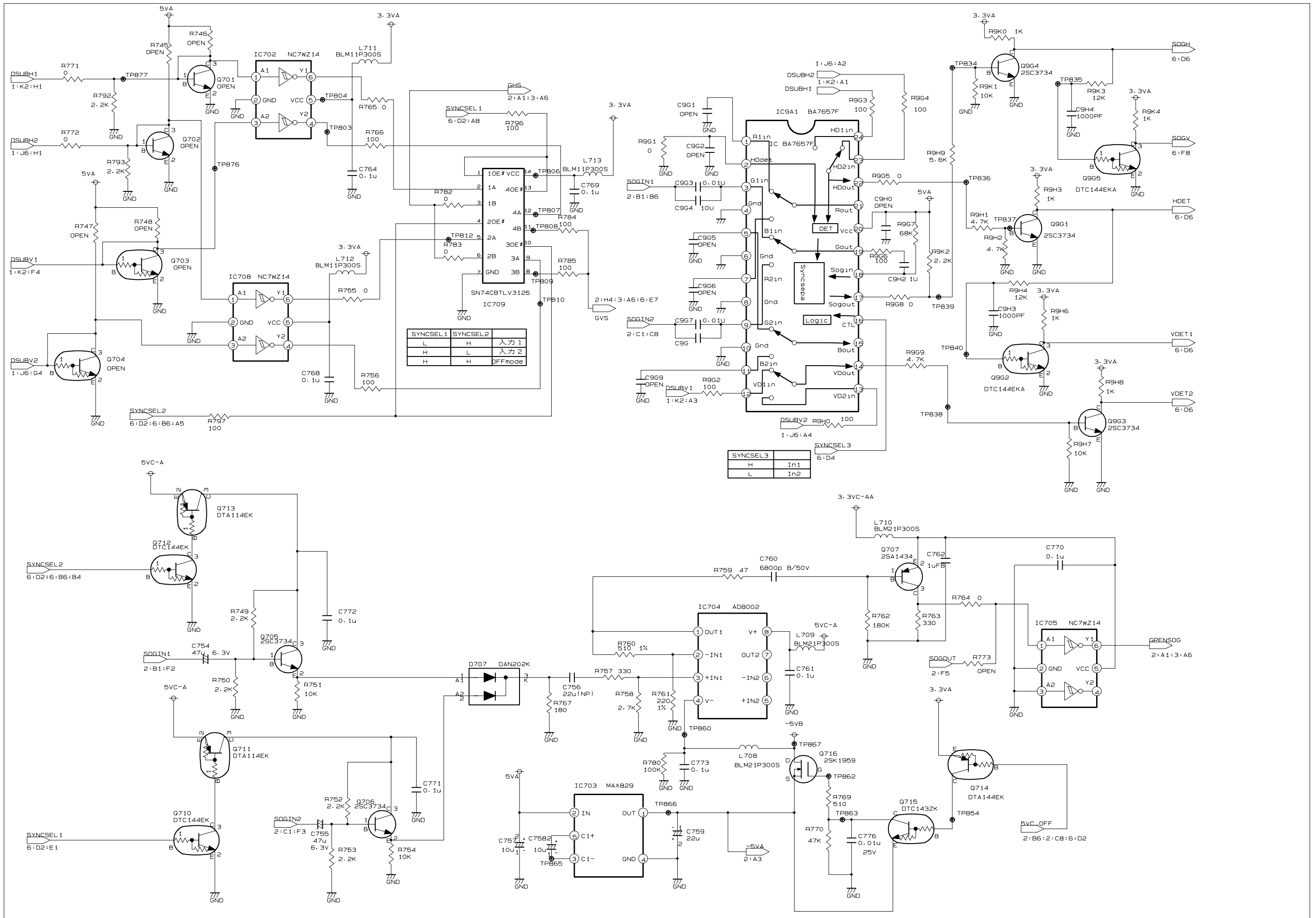

MODEL LCD1830 CONTROL PWB SCHEMATIC DIAGRAM(1/1)

