



Website:<http://biz.LGservice.com>
E-mail:<http://www.LGService.com/techsup.html>

COLOR MONITOR SERVICE MANUAL

CHASSIS NO. : LP69G

MODEL: FLATRON M228WA (M228WA-BZH.A**QLP)

*() **Same model for Service

CAUTION

BEFORE SERVICING THE UNIT,
READ THE **SAFETY PRECAUTIONS** IN THIS MANUAL.

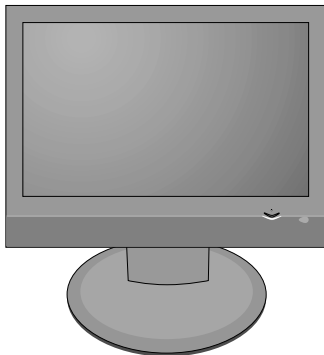

CONTENTS

SPECIFICATIONS	2	ADJUSTMENT	17
PRECAUTIONS	8	TROUBLESHOOTING GUIDE	24
DISASSEMBLY	12	EXPLODED VIEW	30
BLOCK DIAGRAM	14	REPLACEMENT PARTS LIST	32
DESCRIPTION OF BLOCK DIAGRAM.....	15	SCHEMATIC DIAGRAM.....	40

SPECIFICATION

NOTE : Specifications and others are subject to change without notice for improvement.

1. Application range

This specification is applied to 22" Wide Monitor TV used LP69G chassis.

2. Requirement for Test

Each part is tested as below without special appointment.

- (1) Power Voltage : Standard input voltage (100~240V@, 50/60Hz)
*Standard Voltage of each products is marked by models.
- (2) Specification and performance of each parts are followed each drawing and specification by part number in accordance with BOM.
- (3) The receiver must be operated for about 20 minutes prior to the adjustment.

3. Test method

- 3.1 Performance : LGE test method followed
- 3.2 Demanded other specification
Safety : CE, IEC Specification
EMC : CE, IEC

4. General Specification(TV)

4-1. General Specification

4.1.1 TV

No	Item	Specification	Remark
1	Video input applicable system	PAL-D/K, B/G, I, SECAM L, NTSC, NTSC 4.43	
2	Receivable Broadcasting System	PAL/SECAM BG PAL/SECAM DK PAL I SECAM L/L'	(BZH/BTH) EU/Non-EU (PAL Market)
3	RF Input Channel	VHF : E2 ~ E12 UHF : E21 ~ E69 CATV : S1 ~ S20 HYPER : S21~ S41	PAL
		L/L' : B, C, D	FRANCE
4	Input Voltage	100-240V~, 50Hz/60Hz	
5	Market	EU	
6	Tuning System	FVS 100 program	PAL, 200 PR.(Option)
		FS	NTSC
7	Operating Environment	Temp : 10°C~ 35°C	
		Humidity : 20% ~ 80%	
8	Storage Environment	Temp : -10°C ~ 60°C non condensing	
		Humidity : 5%~90% non condensing	
9	Display	LCD Module	

4.1.2 RGB/DVI

No.	Item	Specification				Remark	
1	Supported Sync. Type	Separate Sync., Digital					
2	Operating Frequency	Analog	Horizontal	28 ~ 83kHz			
			Vertical	56 ~ 75 Hz			
		Digital	Horizontal	28 ~ 83kHz			
			Vertical	56 ~ 75 Hz			
3	Resolution	Analog	Max.	1680 x 1050 @ 60Hz			
			Recommend	1680 x 1050 @ 60Hz			
		Digital	Max.	1680 x 1050 @ 60Hz			
			Recommend	1680 x 1050 @ 60Hz			
4	Input Voltage	Voltage :100 - 240 Vac, 50 or 60Hz					
5	Inrush Current	Cold Start : 50 A Hot : 120 A					
6	Operating Condition	Sync (H/V)	Video	LED	Wattage		
	Power S/W On	On mode	On/On	Active	Blue	60W	Max.
			On/On	Active	Blue	50W	Typ.
	Sleep mode	Off/On	Off	Amber	1W		
		On/Off					
Power S/W Off	Off mode	-	Off	Off	1W		
7	MTBF	50,000 HRS with 90% Confidence level				Lamp Life : 50,000 Hours(min)	
8	Using Altitude	5,000 m (for Reliability) 3,000m(for FOS)					
9	Operating Environment	Temp : 10°C ~ 35°C					
		Humidity : 20% ~ 80%					
10	Storage Environment	Temp : -10°C ~ 60°C non condensing					
		Humidity : 5% ~ 90% non condensing					

4-2. Module Specification(CMO M220Z1-L01, P/N:EAJ33527501_ZBD, EAJ33527502_Non-ZBD)

No.	Item	Min	Typ.	Max	Unit	Remark
1.	Type	TFT Color LCD Module				
2.	Active Display area	473.76 (H) x 296.1 (V)			mm	
3.	Outline dimension	493.7 (H) x 320.1 (V) x16.5 (D)			mm	Typ
4.	Pixel pitch	0.282mm (H) x 0.282mm (V) x RGB			mm	
5.	Color arrangement	RGB vertical stripe				
6.	Color Depth	16.7M color				
7.	Electrical Interface	LVDS				
8.	Surface Treatment	Hard coating(3H) & Anti-glare(Haze 25)				
9.	Operating Mode	Normally White				
10.	Back light Unit	4 CCFL (4 lamps)				
11.	R/T	R.T : 2ms + R.T : 3ms				Typ.

4-3. Optical characteristic specifications

4.3.1 Optical Characteristic

No.	Item	Specification				Remark			
			Min	Typ	Max				
1	Viewing Angle <CR≥10>	R/L	75/75	85/85					
		U/D	70/70	80/80					
2	Luminance (cd/m2)	Luminance	RGB-PC	250	300		PSM:Dynamic, CSM: 6500K		
			AV1/AV2/TV Component	190	230		PSM:Dynamic, CSM:Cool		
		White Luminance Uniformity			1.3	1.5			
3	Contrast Ratio	CR	RGB-PC/ AV1/AV2/TV/ Component	450	700		At DFC Mode Typ. 3000:1, Min. 2400:1		
4	CIE Color Coordinates	WHITE	Wx	Typ. -0.03	0.313	Typ. +0.03	In RGB-PC input PSM : Dynamic CSM : 6500K White (100 IRE)		
			Wy		0.329				
		RED	Rx		0.644				
			Ry		0.333				
		GREEN	Gx		0.286				
			Gy		0.605				
		BLUE	Bx		0.152				
			By		0.076				
		WHITE	Wx		Typ. -0.015		0.285	Typ. +0.015	In AV1/AV2/Component/TV input PSM : Dynamic CSM : Cool White (85 IRE)
			Wy				0.293		
		RED	Rx				0.640		
			Ry				0.334		
		GREEN	Gx				0.286		
			Gy				0.599		
BLUE	Bx	0.154							
	By	0.077							

4-4. Model Specification

No	Item	Specification	Remark
1.	Market	EU	
2.	Broadcasting system	PAL BG/I/DK, SECAM-L/L', SECAM BG/DK	
3	RF Input Channel	VHF : E2 ~ E12 UHF : E21 ~ E69 CATV : S1 ~ S20 HYPER : S21~ S41	PAL
		L/L' : B, C, D	FRANCE
4.	SCART Input (1EA)	PAL, SECAM	
5.	CVBS Input (1EA)	PAL, SECAM, NTSC	4 System(Rear) : PAL50, SECAM, NTSC, PAL60
6.	S-Video Input (1EA)	PAL, SECAM, NTSC	4 System(Rear) : PAL50, SECAM, NTSC, PAL60
7.	Component Input (1EA)	Y/ Pb/Pr	480i/480p/576i/576p/720p/1080i
8.	RGB Input (1EA)	RGB-PC	Max 1680 * 1050@60Hz
		RGB-DTV	480p, 576p, 720p, 1080i
9.	DVI Input (1EA)	DVI-PC	Max 1680 * 1050@60Hz
		DVI-DTV	480p, 576p, 720p, 1080i
10.	Audio Input (3 EA)	CVBS, PC Audio, Component	L/R Input

5. Component Video Input (Y, PB, PR)

No	Resolution	H-freq(kHz)	V-freq.(kHz)	Pixel clock(MHz)	Proposed
1.	720*480	15.73	59.94	13.500	480i
2.	720*480	15.75	60.00	13.514	480i
3.	720*576	15.625	50.00	13.500	576i
4.	720*480	31.47	59.94	27.000	480p
5.	720*480	31.50	60.00	27.027	480p
6.	720*576	31.25	50.00	27.000	576p
7.	1280*720	44.96	59.94	74.176	720p
8.	1280*720	45.00	60.00	74.250	720p
9.	1280*720	37.50	50.00	74.25	720p
10.	1920*1080	33.72	59.94	74.176	1080i
11.	1920*1080	33.75	60.00	74.250	1080i
12.	1920*1080	28.125	50.00	74.250	1080i

6. RGB Input (PC)

No	Resolution	H-freq(kHz)	V-freq.(Hz)	Pixel clock(MHz)
1	720*400	31.468	70.08	28.321
2	640*480	31.469	59.94	25.175
3	640*480	37.5	75	31.5
4	800*600	37.879	60.317	40.0
5	800*600	46.875	75.0	49.5
6	1024*768	48.363	60.0	65.0
7	1024*768	60.123	75.029	78.75
8	1152*864	67.500	75.000	108.0
9	1280*1024	63.981	60.02	108.0
10	1280*1024	79.976	75.035	135.0
11	1680*1050	64.674	59.883	119.0
12	1680*1050	65.290	59.954	146.25

7. RGB input (DTV)

No	Resolution	H-freq(kHz)	V-freq.(kHz)	Pixel clock(MHz)	Proposed
1.	720*480	31.47	59.94	27.000	480p
2.	720*480	31.50	60.00	27.027	480p
3.	720*576	31.25	50.00	27.000	576p
4.	1280*720	37.5	50.00	74.250	720p
5.	1280*720	44.96	59.94	74.176	720p
6.	1280*720	45.00	60.00	74.250	720p
7.	1920*1080	33.72	59.94	74.176	1080i
8	1920*1080	33.75	60.00	74.250	1080i
9	1920*1080	28.125	50.00	74.250	1080i

8. DVI input (PC)

No	Resolution	H-freq(kHz)	V-freq.(Hz)	Pixel clock(MHz)
1	720*400	31.468	70.08	28.321
2	640*480	31.469	59.94	25.175
3	640*480	37.5	75	31.5
4	800*600	37.879	60.317	40.0
5	800*600	46.875	75.0	49.5
6	1024*768	48.363	60.0	65.0
7	1024*768	60.123	75.029	78.75
8	1152*864	67.500	75.000	108.0
9	1280*1024	63.981	60.02	108.0
10	1280*1024	79.976	75.035	135.0
11	1680*1050	64.674	59.883	119.0
12	1680*1050	65.290	59.954	146.25

9. DVI input (DTV)

No	Resolution	H-freq(kHz)	V-freq.(kHz)	Pixel clock(MHz)	Proposed
1.	720*480	31.47	59.94	27.000	480p
2.	720*480	31.50	60.00	27.027	480p
3.	720*576	31.25	50.00	27.000	576p
4.	1280*720	37.5	50.00	74.250	720p
5.	1280*720	44.96	59.94	74.176	720p
6.	1280*720	45.00	60.00	74.250	720p
7.	1920*1080	33.72	59.94	74.176	1080i
8.	1920*1080	33.75	60.00	74.250	1080i
9.	1920*1080	28.125	50.00	74.250	1080i

PRECAUTION

WARNING FOR THE SAFETY-RELATED COMPONENT.

- There are some special components used in LCD monitor that are important for safety. **These parts are marked \triangle on the schematic diagram and the replacement parts list.** It is essential that these critical parts should be replaced with the manufacturer's specified parts to prevent electric shock, fire or other hazard.
- Do not modify original design without obtaining written permission from manufacturer or you will void the original parts and labor guarantee.

TAKE CARE DURING HANDLING THE LCD MODULE WITH BACKLIGHT UNIT.

- Must mount the module using mounting holes arranged in four corners.
- Do not press on the panel, edge of the frame strongly or electric shock as this will result in damage to the screen.
- Do not scratch or press on the panel with any sharp objects, such as pencil or pen as this may result in damage to the panel.
- Protect the module from the ESD as it may damage the electronic circuit (C-MOS).
- Make certain that treatment person's body are grounded through wrist band.
- Do not leave the module in high temperature and in areas of high humidity for a long time.
- The module not be exposed to the direct sunlight.
- Avoid contact with water as it may a short circuit within the module.
- If the surface of panel become dirty, please wipe it off with a softmaterial. (Cleaning with a dirty or rough cloth may damage the panel.)

\triangle CAUTION

Please use only a plastic screwdriver to protect yourself from shock hazard during service operation.

\triangle WARNING

BE CAREFUL ELECTRIC SHOCK !

- If you want to replace with the new backlight (CCFL) or inverter circuit, must disconnect the AC adapter because high voltage appears at inverter circuit about 650Vrms.
- Handle with care wires or connectors of the inverter circuit. If the wires are pressed cause short and may burn or take fire.

Leakage Current Hot Check Circuit

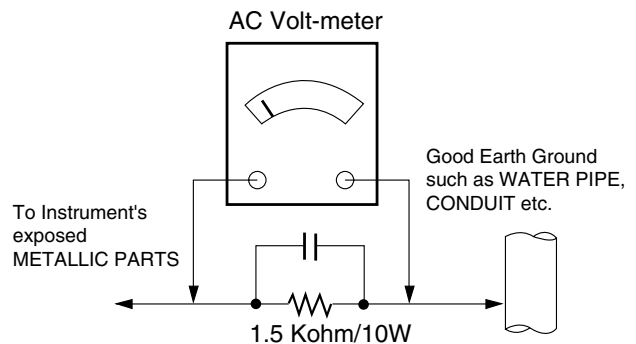

SERVICING PRECAUTIONS

CAUTION: Before servicing receivers covered by this service manual and its supplements and addenda, read and follow the **SAFETY PRECAUTIONS** on page 3 of this publication.

NOTE: If unforeseen circumstances create conflict between the following servicing precautions and any of the safety precautions on page 3 of this publication, always follow the safety precautions. Remember: Safety First.

General Servicing Precautions

1. Always unplug the receiver AC power cord from the AC power source before;
 - a. Removing or reinstalling any component, circuit board module or any other receiver assembly.
 - b. Disconnecting or reconnecting any receiver electrical plug or other electrical connection.
 - c. Connecting a test substitute in parallel with an electrolytic capacitor in the receiver.

CAUTION: A wrong part substitution or incorrect polarity installation of electrolytic capacitors may result in an explosion hazard.

- d. Discharging the picture tube anode.
2. Test high voltage only by measuring it with an appropriate high voltage meter or other voltage measuring device (DVM, FETVOM, etc) equipped with a suitable high voltage probe.
Do not test high voltage by "drawing an arc".
 3. Discharge the picture tube anode only by (a) first connecting one end of an insulated clip lead to the degaussing or kine aquadag grounding system shield at the point where the picture tube socket ground lead is connected, and then (b) touch the other end of the insulated clip lead to the picture tube anode button, using an insulating handle to avoid personal contact with high voltage.
 4. Do not spray chemicals on or near this receiver or any of its assemblies.
 5. Unless specified otherwise in this service manual, clean electrical contacts only by applying the following mixture to the contacts with a pipe cleaner, cotton-tipped stick or comparable non-abrasive applicator; 10% (by volume) Acetone and 90% (by volume) isopropyl alcohol (90%-99% strength)

CAUTION: This is a flammable mixture.

Unless specified otherwise in this service manual, lubrication of contacts is not required.

6. Do not defeat any plug/socket B+ voltage interlocks with which receivers covered by this service manual might be equipped.
7. Do not apply AC power to this instrument and/or any of its electrical assemblies unless all solid-state device heat sinks are correctly installed.
8. Always connect the test receiver ground lead to the receiver chassis ground before connecting the test receiver positive lead.
Always remove the test receiver ground lead last.

9. Use with this receiver only the test fixtures specified in this service manual.

CAUTION: Do not connect the test fixture ground strap to any heat sink in this receiver.

Electrostatically Sensitive (ES) Devices

Some semiconductor (solid-state) devices can be damaged easily by static electricity. Such components commonly are called *Electrostatically Sensitive (ES) Devices*. Examples of typical ES devices are integrated circuits and some field-effect transistors and semiconductor "chip" components. The following techniques should be used to help reduce the incidence of component damage caused by static by static electricity.

1. Immediately before handling any semiconductor component or semiconductor-equipped assembly, drain off any electrostatic charge on your body by touching a known earth ground. Alternatively, obtain and wear a commercially available discharging wrist strap device, which should be removed to prevent potential shock reasons prior to applying power to the unit under test.
2. After removing an electrical assembly equipped with ES devices, place the assembly on a conductive surface such as aluminum foil, to prevent electrostatic charge buildup or exposure of the assembly.
3. Use only a grounded-tip soldering iron to solder or unsolder ES devices.
4. Use only an anti-static type solder removal device. Some solder removal devices not classified as "anti-static" can generate electrical charges sufficient to damage ES devices.
5. Do not use freon-propelled chemicals. These can generate electrical charges sufficient to damage ES devices.
6. Do not remove a replacement ES device from its protective package until immediately before you are ready to install it. (Most replacement ES devices are packaged with leads electrically shorted together by conductive foam, aluminum foil or comparable conductive material).
7. Immediately before removing the protective material from the leads of a replacement ES device, touch the protective material to the chassis or circuit assembly into which the device will be installed.
CAUTION: Be sure no power is applied to the chassis or circuit, and observe all other safety precautions.
8. Minimize bodily motions when handling unpackaged replacement ES devices. (Otherwise harmless motion such as the brushing together of your clothes fabric or the lifting of your foot from a carpeted floor can generate static electricity sufficient to damage an ES device.)

General Soldering Guidelines

1. Use a grounded-tip, low-wattage soldering iron and appropriate tip size and shape that will maintain tip temperature within the range of 500°F to 600°F.
2. Use an appropriate gauge of RMA resin-core solder composed of 60 parts tin/40 parts lead.
3. Keep the soldering iron tip clean and well tinned.
4. Thoroughly clean the surfaces to be soldered. Use a small wire-bristle (0.5 inch, or 1.25cm) brush with a metal handle.

Do not use freon-propelled spray-on cleaners.

5. Use the following unsoldering technique
 - a. Allow the soldering iron tip to reach normal temperature.
(500°F to 600°F)
 - b. Heat the component lead until the solder melts.
 - c. Quickly draw the melted solder with an anti-static, suction-type solder removal device or with solder braid.
6. Use the following soldering technique.
 - a. Allow the soldering iron tip to reach a normal temperature (500°F to 600°F)
 - b. First, hold the soldering iron tip and solder the strand against the component lead until the solder melts.

- c. Quickly move the soldering iron tip to the junction of the component lead and the printed circuit foil, and hold it there only until the solder flows onto and around both the component lead and the foil.

CAUTION: Work quickly to avoid overheating the circuit board printed foil.

- d. Closely inspect the solder area and remove any excess or splashed solder with a small wire-bristle brush.

IC Remove/Replacement

Some chassis circuit boards have slotted holes (oblong) through which the IC leads are inserted and then bent flat against the circuit foil. When holes are the slotted type, the following technique should be used to remove and replace the IC. When working with boards using the familiar round hole, use the standard technique as outlined in paragraphs 5 and 6 above.

Removal

1. Desolder and straighten each IC lead in one operation by gently prying up on the lead with the soldering iron tip as the solder melts.
2. Draw away the melted solder with an anti-static suction-type solder removal device (or with solder braid) before removing the IC.

Replacement

1. Carefully insert the replacement IC in the circuit board.
2. Carefully bend each IC lead against the circuit foil pad and solder it.
3. Clean the soldered areas with a small wire-bristle brush. (It is not necessary to reapply acrylic coating to the areas).

"Small-Signal" Discrete Transistor

Removal/Replacement

1. Remove the defective transistor by clipping its leads as close as possible to the component body.
2. Bend into a "U" shape the end of each of three leads remaining on the circuit board.
3. Bend into a "U" shape the replacement transistor leads.
4. Connect the replacement transistor leads to the corresponding leads extending from the circuit board and crimp the "U" with long nose pliers to insure metal to metal contact then solder each connection.

Power Output, Transistor Device

Removal/Replacement

1. Heat and remove all solder from around the transistor leads.
2. Remove the heat sink mounting screw (if so equipped).
3. Carefully remove the transistor from the heat sink of the circuit board.
4. Insert new transistor in the circuit board.
5. Solder each transistor lead, and clip off excess lead.
6. Replace heat sink.

Diode Removal/Replacement

1. Remove defective diode by clipping its leads as close as possible to diode body.
2. Bend the two remaining leads perpendicular y to the circuit board.
3. Observing diode polarity, wrap each lead of the new diode around the corresponding lead on the circuit board.
4. Securely crimp each connection and solder it.
5. Inspect (on the circuit board copper side) the solder joints of the two "original" leads. If they are not shiny, reheat them and if necessary, apply additional solder.

Fuse and Conventional Resistor

Removal/Replacement

1. Clip each fuse or resistor lead at top of the circuit board hollow stake.
2. Securely crimp the leads of replacement component around notch at stake top.
3. Solder the connections.

CAUTION: Maintain original spacing between the replaced component and adjacent components and the circuit board to prevent excessive component temperatures.

Circuit Board Foil Repair

Excessive heat applied to the copper foil of any printed circuit board will weaken the adhesive that bonds the foil to the circuit board causing the foil to separate from or "lift-off" the board. The following guidelines and procedures should be followed whenever this condition is encountered.

At IC Connections

To repair a defective copper pattern at IC connections use the following procedure to install a jumper wire on the copper pattern side of the circuit board. (Use this technique only on IC connections).

1. Carefully remove the damaged copper pattern with a sharp knife. (Remove only as much copper as absolutely necessary).
2. Carefully scratch away the solder resist and acrylic coating (if used) from the end of the remaining copper pattern.
3. Bend a small "U" in one end of a small gauge jumper wire and carefully crimp it around the IC pin. Solder the IC connection.
4. Route the jumper wire along the path of the out-away copper pattern and let it overlap the previously scraped end of the good copper pattern. Solder the overlapped area and clip off any excess jumper wire.

At Other Connections

Use the following technique to repair the defective copper pattern at connections other than IC Pins. This technique involves the installation of a jumper wire on the component side of the circuit board.

1. Remove the defective copper pattern with a sharp knife.
Remove at least 1/4 inch of copper, to ensure that a hazardous condition will not exist if the jumper wire opens.
2. Trace along the copper pattern from both sides of the pattern break and locate the nearest component that is directly connected to the affected copper pattern.
3. Connect insulated 20-gauge jumper wire from the lead of the nearest component on one side of the pattern break to the lead of the nearest component on the other side.
Carefully crimp and solder the connections.

CAUTION: Be sure the insulated jumper wire is dressed so the it does not touch components or sharp edges.

DISASSEMBLY

1



1. Push down slightly to disassembly it.
2. After push the cable management like above fig.(Downward), Disassembly the Cable management with pulling it upward.
3. Disassembly Cable Holder.

2



Push the button.

3



Hold the stand base.

4

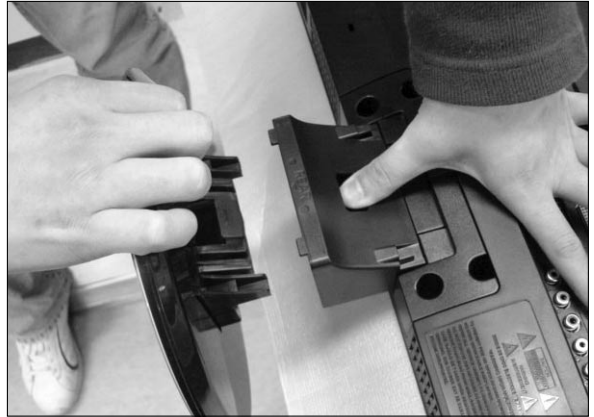

Disassembly Stand base.

5

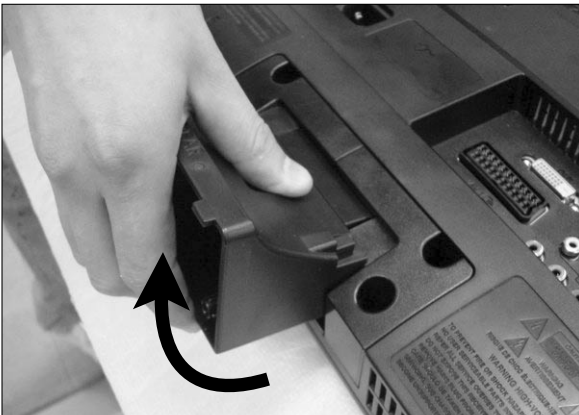

Remove base body Like a picture.

6

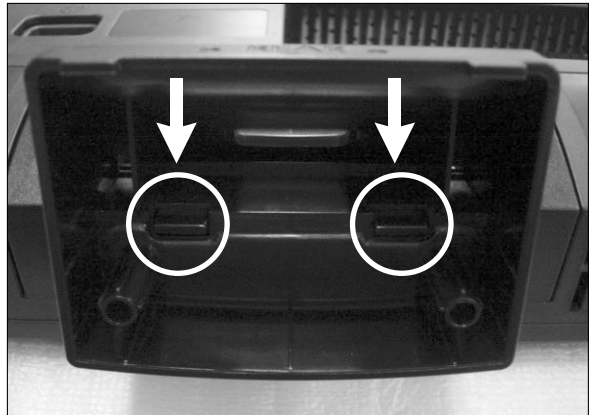

Push 2 latches Like a picture.

7



Pull base body to separate from set during pressing 2 latches.

8

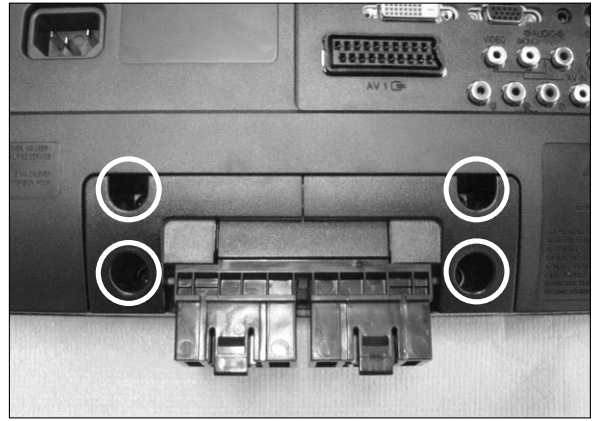

1. Remove the screws.
2. Disassembly Hinge Cover.

9



Remove the screws.

10

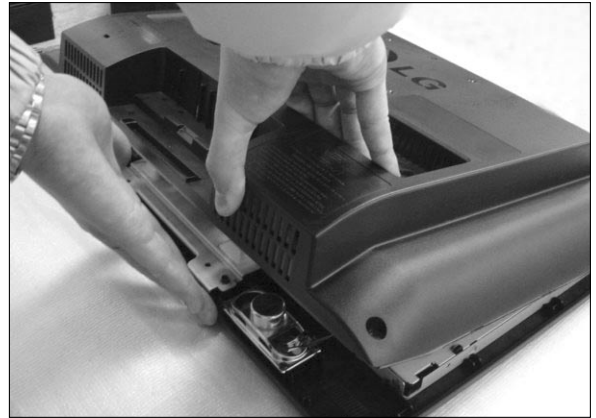

Disassembly back cover.

11

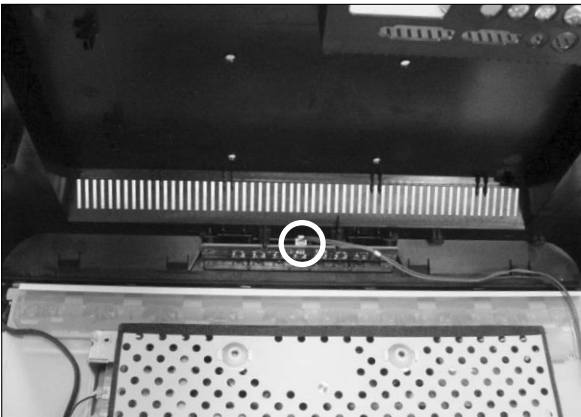

Pull the connector.

BLOCK DIAGRAM

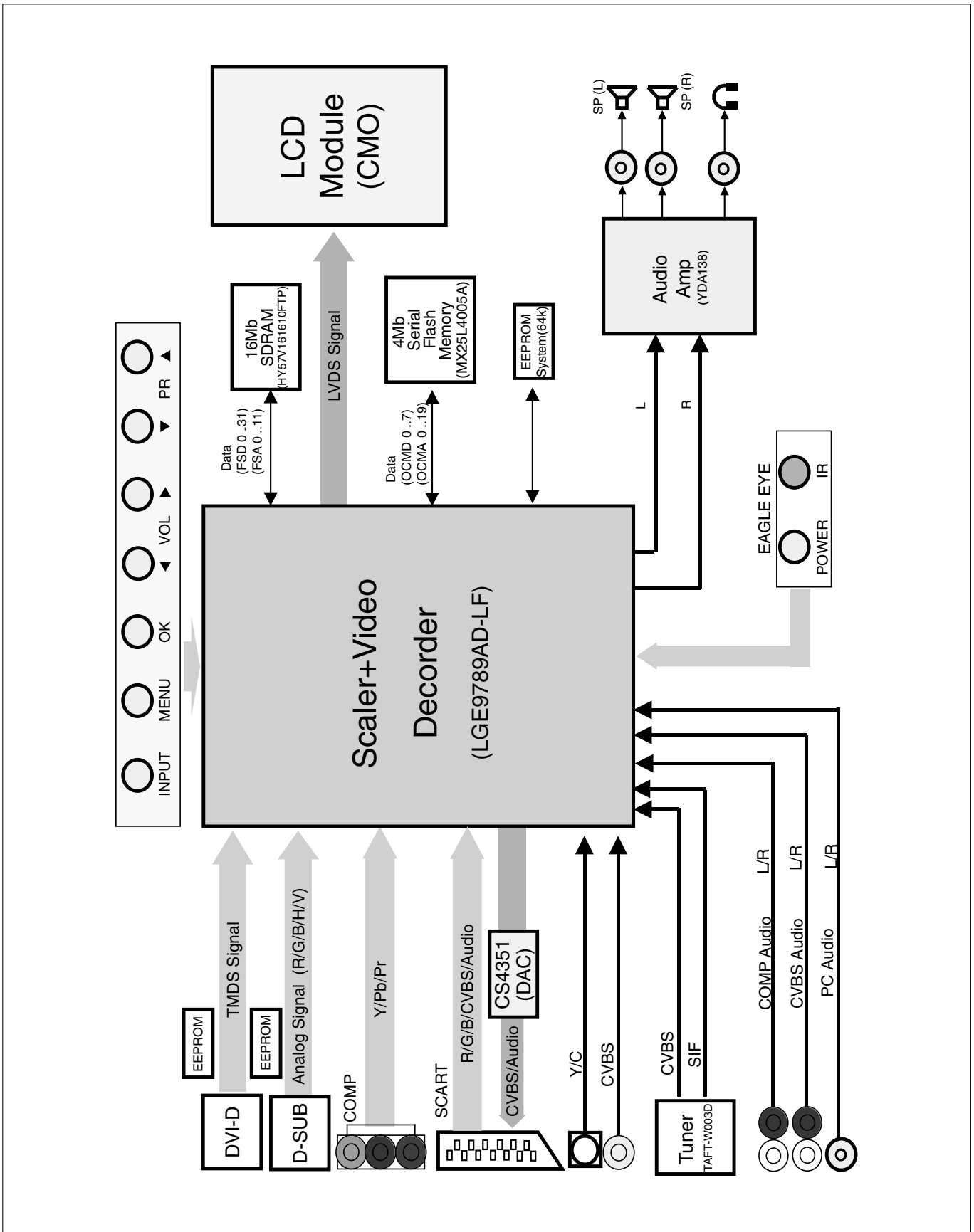

DESCRIPTION OF BLOCK DIAGRAM

1. Power Supply Block (LIPS)

This Block Generates DC Voltage (5V,15V) to Main Control system from AC Power (100-240 V, 50/60 Hz, 1.0A)

2. DC/DC Converter block

DC/DC Converter convert the input 5V,15V to proper 1.8V,2.5V,3.3V,5V,10.5V for Main control system.
For shooting heat trouble, we use the DC/DC converting IC

3. Scaler + Video/Audio decoder (Scaler IC, LGE9789AD-LF)

It is composed of LGE9789AD-LF.

It includes AD Converter, LVDS/TMDS Transmitter, Micom, and Audio processor.

1) Video Signal - CVBS/S-Video/Component/RGB/DVI(TMDS)

This Block Selects input Video signals (like CVBS, Y/C, SCART RGB) and output RGB signal.

On decoding, We can control signal like Contrast, Brightness, Sharpness, Color, tint signals including Adaptive Comb Filter.

2) Audio Signal

This block analyzes audio input signal through A/V Jack and PC audio and Tuner IF.

The analyzed signals transmitted to audio amplifier (YDA138)

On decoding, We can control signal like Bass, treble.

4. Flash Memory(MX25L4005A)

This is composed of MX25L4005A.

This store the source data of micom.

5. Tuner

Micom controls this IC through IIC line.

Tuner makes CVBS and transmits IF signal to LGE9789AD-LF.

6. Audio Amplifier (YDA138)

This block is composed of YDA138 and peripheral device.

The function of the audio amplifier is that to amplify audio L / R signal transmitted from audio decoder.

The audio signal is amplified according to pre-defined DC volume control curve.

Also, headphone amplifier is included at this IC.

LIPS Board Block Diagram

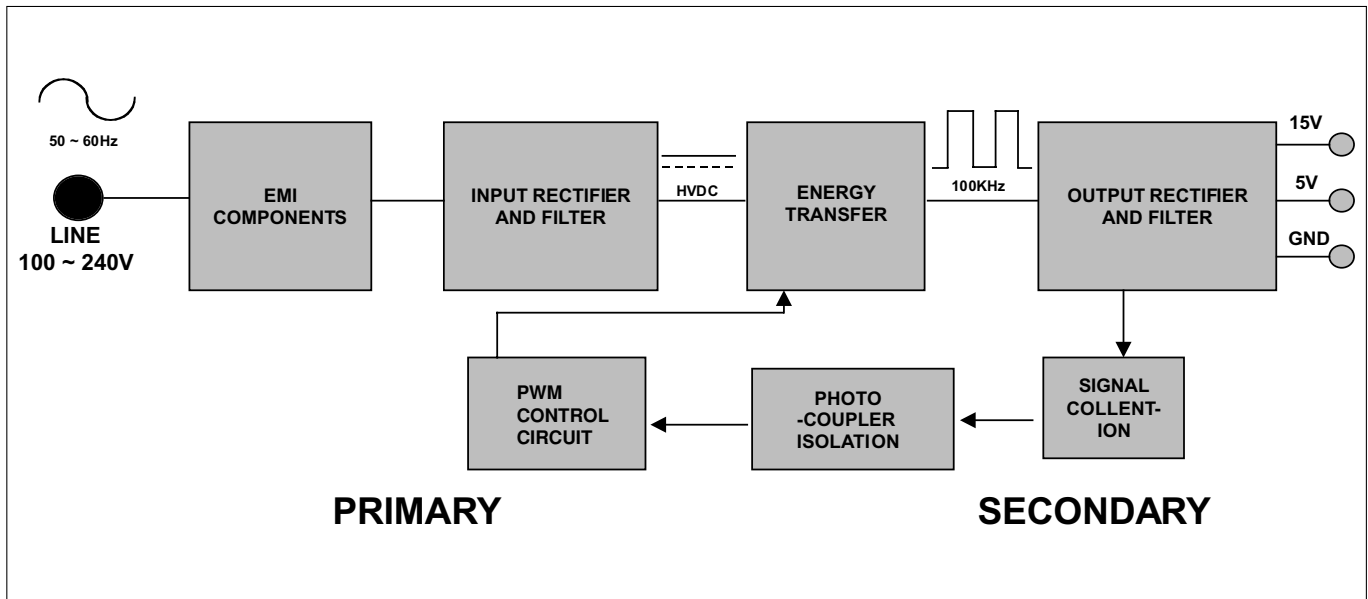

Operation description_LIPS

1. EMI components.

This part contains of EMI components to comply with global marketing EMI standards like FCC,VCCI CISPR, the circuit included a line-filter, across line capacitor and of course the primary protection fuse.

2. Input rectifier and filter.

This part function is for transfer the input AC voltage to a DC voltage through a bridge rectifier and a bulk capacitor.

3. Energy Transfer.

This part function is for transfer the primary energy to secondary through a power transformer.

4. Output rectifier and filter.

This part function is to make a pulse width modulation control and to provide the driver signal to power switch, to adjust the duty cycle during different AC input and output loading condition to achieve the dcoutput stabilized, and also the over power protection is also monitor by this part.

5. Photo-Coupler isolation.

This part function is to feed back the DC output changing status through a photo transistor to primary controller to achieve the stabilized DC output voltage.

6. Signal collection.

This part function is to collect the any change from the DC output and feed back to the primary through photo transistor.

ADJUSTMENT

Windows EDID V1.0 User Manual

Operating System: MS Windows 98, 2000, XP
 Port Setup: Windows 98 => Don't need setup
 Windows 2000, XP => Need to Port Setup.
 This program is available to LCD Monitor only.

1. Port Setup

- a) Copy "UserPort.sys" file to "c:\WINNT\system32\drivers" folder
- b) Run Userport.exe

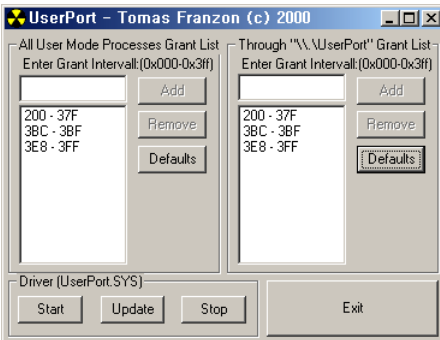

- c) Remove all default number
- d) Add 300-3FF

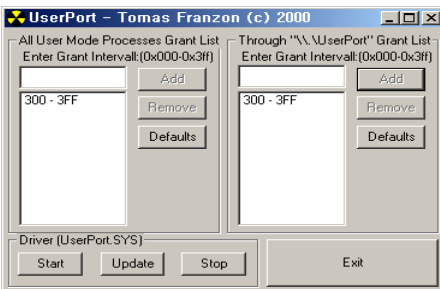

- e) Click Start button.
- f) Click Exit button.

2. EDID Read & Write

1) Run WinEDID.exe

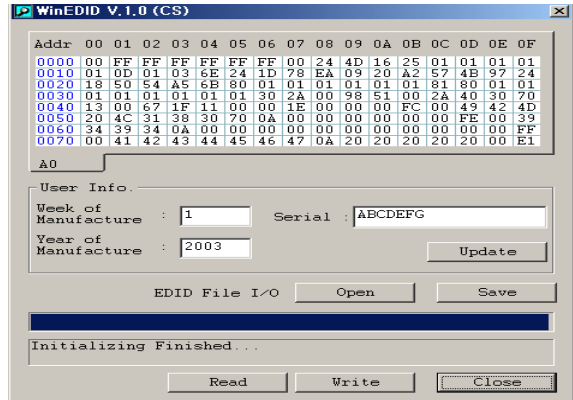

2) Edit Week of Manufacture, Year of Manufacture, Serial Number

- a) Input User Info Data
- b) Click "Update" button
- c) Click "Write" button

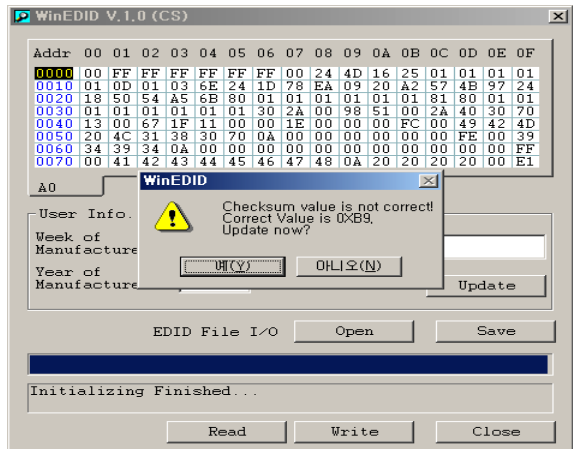

ADJUSTMENT INSTRUCTION

1. Application Range

This specification sheet is applied to 19"/ 20"/ 22" LCD Monitor TV which is manufactured in TV (or Monitor) Factory or is produced on the basis of this data.

2. Specification

- 1) The adjustment is according to the order which is designated and which must be followed, according to the plan which can be changed only on agreeing.
- 2) Power Adjustment : Free Voltage
- 3) Magnetic Field Condition : Nil.
- 4) Input signal Unit : Product Specification Standard
- 5) Reserve after operation : Above 30 Minutes
- 6) Adjustment equipments : Color Analyzer(CA-210 or CA-110), Pattern Generator (MSPG-925L or Equivalent), DDC Adjustment Jig equipment, SVC remote controller

3. Main PCB check process

* APC - After Manual-Insult, executing APC

3.1. Download

- 1) Execute ISP program "Mstar ISP Utility" and then click "Config" tab.
- 2) Set as below, and then click "Auto Detect" and check "OK" message.
If display "Error", Check connect computer, jig, and set.
- 3) Click "Connect" tab.
If display "Can't", Check connect computer, jig, and set.

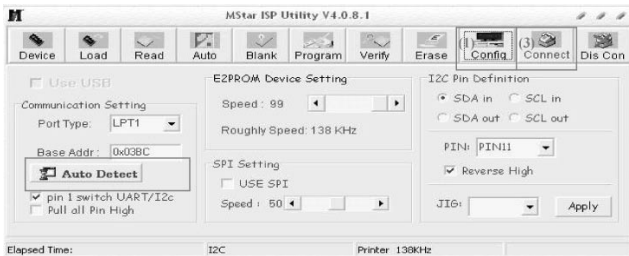

- 4) Click "Read" tab, and then load download file(XXXX.bin) by clicking "Read".

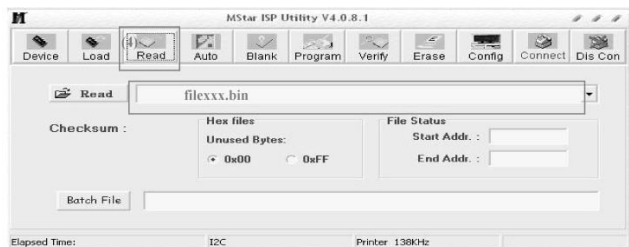

- 5) Click "Auto" tab and set as below
- 6) click "Run".
- 7) After downloading, check "OK" message.

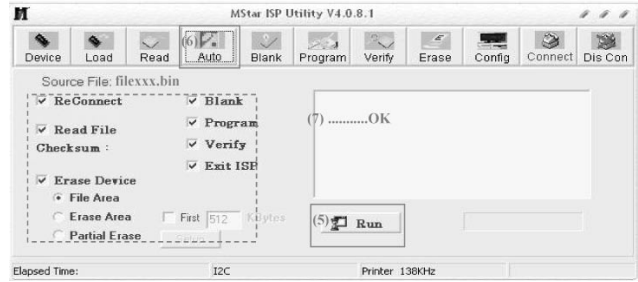

3.2. ADC Process

* If a scaler IC changed for PCB repairing, it is need to do ADC process at all times.

(1) PC input ADC

- 1) Auto RGB Gain/Offset Adjustment
 - Convert to PC in Input-source
 - Signal equipment displays
Output Voltage : 700 mVp-p
Impress Resolution XGA (1024 x 768 @ 60Hz)
Model : 60 in Pattern Generator
Pattern : 29 in Pattern Generator (MSPG-925 SERISE)
[gray pattern that left & right is black and center is white signal (Refer below picture)].

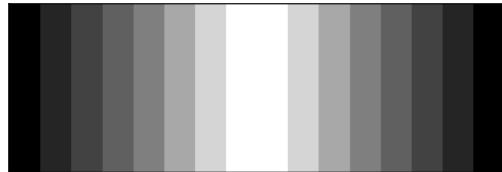

<Adjustment pattern (PC)>

- Adjust by commanding AUTO_COLOR_ADJUST (0xF1) 0x00 0x02 instruction.
- 2) Confirmation
 - We confirm whether "0x8B,0x8C" address of EEPROM "0xB4" is "0xAA" or not.
 - If "0x8B,0x8C" address of EEPROM "0xB4" isn't "0xAA", we adjust once more.
 - We can confirm the ADC values from "0x00~0x05" addresses in a page "0xB4"

* Manual ADC process using Service Remocon. After enter Service Mode by pushing "INSTART" key, execute "Auto-RGB" by pushing "_" key at "Auto-RGB".

(2) COMPONENT input ADC

- 1) Component Gain/Offset Adjustment
 - Convert to Component in Input-source
 - Signal equipment displays
Impress Resolution 480P
MODEL : 212 in Pattern Generator
(480p Mode, Y : 100%, Pb/Pr : 75%)
PATTERN : 08 in Pattern Generator
(MSPG-925 SERISE)



<Adjustment pattern (COMPONENT)>

- Adjust by commanding AUTO_COLOR_ADJUST (0xF1) 0x00 0x02 instruction.

2) Confirmation

- We confirm whether "0x8D,0x8E" address of EEPROM "0xB4" is "0xAA" or not.
- If "0x8D,0x8E" address of EEPROM "0xB4" isn't "0xAA", we adjust once more.
- We can confirm the ADC values from "0x00~0x05" addresses in a page "0xB4".

3.3. Function Check

(1) Check display and sound

- Check Input and Signal items. (cf. work instructions)

- 1) TV
- 2) AV1 (SCART)
- 3) AV2 (CVBS/ S-Video)
- 4) COMPONENT (480P)
- 5) RGB (PC : 1024 x 768 @ 60hz)
- 6) DVI
- 7) PC Audio In and H/P Out

* Display and Sound check is executed by Remote controller.

4. Total Assembly line process

4.1. Adjustment Preparation

- (1) Above 30 minutes H/run in RF no signal
- (2) 15 Pin D-Sub Jack is connected to the signal of Pattern Generator.

4.2. Confirm color coordinate of RGB

* Check White Balance

- Set Input to RGB.
- Input signal : (1024 x 768 @ 60Hz), Full white 255/255 gray level (100 IRE, Model : 60, Pattern : 4 at MSPG925L)
- Set CSM : 6500k
- Confirm whether $x = 0.313 \pm 0.03$, $y = 0.329 \pm 0.03$ or not.
- Confirm whether luminance over 200cd/m²
- Set CSM : 9300k
- Confirm whether $x = 0.283 \pm 0.03$, $y = 0.298 \pm 0.03$ or not.

* Check sRGB

- Set Input to RGB.
- Input signal : (1024 x 768 @ 60Hz)
Full white 255/255 gray level (100 IRE, Model : 60, Pattern : 4 at MSPG925L)
- Set CSM : sRGB
- Confirm whether $x = 0.313 \pm 0.03$, $y = 0.329 \pm 0.03$ or not.
- Confirm whether luminance = 180 ± 50 cd/m²

4.3. Confirm color coordinate of AV2

- (1) Set Input to AV2
- (2) Input signal : CVBS, PAL @ 50Hz
Full white 216/255 gray level (85 IRE, Model : 202, Pattern : 78 at MSPG925L)
- (3) Set PSM : Dynamic / CSM : Cool
- (4) Confirm whether $x = 0.285 \pm 0.03$, $y = 0.293 \pm 0.03$ or not.

4.4. Confirm color coordinate of component

- (1) Set Input to COMPONENT.
- (2) Input signal : 480P
Full white 216/255 gray level (85 IRE Model : 212, Pattern : 78 at MSPG925L)
- (3) Set PSM : Dynamic / CSM : Cool
- (4) Confirm whether $x = 0.285 \pm 0.03$, $y = 0.293 \pm 0.03$ or not.

4.5. Confirm Auto adjustment operation.

- (1) Input 1 Dot on/off & Rectangle Pattern at Model 60 (1024 x 768@60Hz).
- (2) Confirm adjustment operation by changing Clock, Phase, H/V Position.
- (3) Check Clock, Phase by pressing AUTO Key after varying the Clock & the Phase

4.6. Other quality

- Confirm that each items satisfy under standard condition that was written product spec.

(1) AV

- 1) Select input AV1 and whether picture is displayed or not. - SCART output displayed or not.
- 2) Select input AV2 (S-video) and whether picture is displayed or not
- 3) Select input AV2 (CVBS) and whether picture is displayed or not.

(2) TV

- Select input TV and check below item
- * In Gumi Factory
 - C05 (E05) – TELETEXT Function Check ; (Applicable to the model that has Teletext code set-up item in Product spec)
 - C07 (E07) – Nicam DUAL Check.
 - C52 (E52) – Nicam Stereo Check.
- Refer to "7.Preset CH information".

(3) RGB

- *M198WA
 - Select input RGB model 112(1440*900@60hz), 64 Gray Scale pattern and whether picture is displayed or not
- *M208WA / M228WA
 - Select input RGB model 122(1680*1050@60hz), 64Gray Scale pattern and whether picture is display or not

(4) COMPONENT

- Select input COMPONENT and whether picture is displayed or not.

(5) DVI

*M198WA

- Select input DVI model 112(1440*900@60hz), 64 Gray Scale pattern and whether picture is displayed or not

*M208WA / M228WA

- Select input DVI model 122(1680*1050@60hz), 64Gray pattern and whether picture is displayed or not.

4.7. DPM operation confirmation

- Check if Power LED Color and Power Consumption operate as standard.

- (1) Set Input to RGB and connect D-sub cable to set.
- (2) Measurement Condition : 230V@ 50Hz (Analog)
- (3) Confirm DPM operation at the state of screen without Signal

4.8 DDC EDID Write

- 1) Connect D-sub Signal Cable to D-Sub Jack.
- 2) Connect HDMI Signal Cable to HDMI Jack.
- 3) Write EDID DATA to EEPROM(AT24C02) by using DDC2B protocol.
- 4) Check whether written EDID data is correct or not. (refer to Product spec).

(1) M198WA EDID DATA

1) ANALOG DATA 128Byte

0x00	0x01	0x02	0x03	0x04	0x05	0x06	0x07	0x08	0x09	0x0A	0x0B	0x0C	0x0D	0x0E	0x0F
00	FF	FF	FF	FF	FF	FF	00	1E	6D	35	4B	01	01	01	01
0x01	01	10	01	03	0C	29	1A	78	EA	9B	B6	A4	53	4B	9D
0x02	14	4F	54	A7	6F	80	95	0F	81	80	81	40	71	4F	01
0x03	01	01	01	01	01	01	9A	29	A0	D0	51	64	22	30	50
0x04	36	00	98	FF	10	00	00	1C	00	00	00	FD	00	38	4B
0x05	53	0E	00	0A	20	20	20	20	20	20	00	00	00	FC	00
0x06	31	39	38	57	41	0A	20	20	20	20	20	20	00	00	FC
0x07	00	0A	20	20	20	20	20	20	20	20	20	20	20	00	6C

2) DIGITAL DATA 256Byte

0x00	0x01	0x02	0x03	0x04	0x05	0x06	0x07	0x08	0x09	0x0A	0x0B	0x0C	0x0D	0x0E	0x0F
00	FF	FF	FF	FF	FF	FF	00	1E	6D	36	4B	01	01	01	01
0x01	01	10	01	03	0C	29	1A	78	EA	9B	B6	A4	53	4B	9D
0x02	14	4F	54	A7	6F	80	95	00	81	80	81	40	71	4F	01
0x03	01	01	01	01	01	01	9A	29	A0	D0	51	64	22	30	50
0x04	36	00	98	FF	10	00	00	1C	00	00	00	FD	00	38	4B
0x05	53	0E	00	0A	20	20	20	20	20	20	00	00	00	FC	00
0x06	31	39	38	57	41	0A	20	20	20	20	20	20	00	00	FC
0x07	00	0A	20	20	20	20	20	20	20	20	20	20	20	00	27

(2) M208WA EDID DATA

1) ANALOG DATA 128Byte

0x00	0x01	0x02	0x03	0x04	0x05	0x06	0x07	0x08	0x09	0x0A	0x0B	0x0C	0x0D	0x0E	0x0F
00	FF	FF	FF	FF	FF	FF	00	1E	6D	51	4E	01	01	01	01
0x01	01	10	01	03	0C	2B	1B	78	EA	CF	C5	A3	5A	49	A0
0x02	12	50	54	A7	6B	80	95	0F	95	00	81	80	81	40	71
0x03	01	01	01	01	01	01	7C	2E	90	A0	60	1A	1E	40	30
0x04	36	00	B2	0E	11	00	00	1A	21	39	98	30	62	1A	27
0x05	68	B0	36	00	B2	0E	11	00	00	1C	00	00	00	FD	00
0x06	4B	1C	53	0F	00	0A	20	20	20	20	20	00	00	00	FC
0x07	00	4D	32	30	38	57	41	0A	20	20	20	20	20	00	EF

2) DIGITAL DATA 256Byte

0x00	0x01	0x02	0x03	0x04	0x05	0x06	0x07	0x08	0x09	0x0A	0x0B	0x0C	0x0D	0x0E	0x0F
00	FF	FF	FF	FF	FF	FF	00	1E	6D	62	4E	01	01	01	01
0x01	01	10	01	03	80	2B	1B	78	EA	CF	C5	A4	5A	49	A0
0x02	12	50	54	A7	6B	80	81	80	81	40	71	4F	01	01	01
0x03	01	01	01	01	01	01	7C	2E	90	A0	60	1A	1E	40	30
0x04	36	00	B2	0E	11	00	00	1A	21	39	98	30	62	1A	27
0x05	68	B0	36	00	B2	0E	11	00	00	1C	00	00	00	FD	00
0x06	4B	1C	53	0F	00	0A	20	20	20	20	20	20	00	00	FC
0x07	00	4D	32	30	38	57	41	0A	20	20	20	20	20	00	AE

(3) M228WA EDID DATA

1) ANALOG DATA 128Byte

0x00	0x01	0x02	0x03	0x04	0x05	0x06	0x07	0x08	0x09	0x0A	0x0B	0x0C	0x0D	0x0E	0x0F
00	FF	FF	FF	FF	FF	FF	00	1E	6D	3C	56	01	01	01	01
0x01	01	10	01	03	0C	2F	1E	78	EA	D4	25	A4	55	49	9B
0x02	13	50	54	A7	6B	80	95	0F	95	00	81	80	81	40	71
0x03	01	01	01	01	01	01	7C	2E	90	A0	60	1A	1E	40	30
0x04	36	00	B2	0E	11	00	00	1A	21	39	98	30	62	1A	27
0x05	68	B0	36	00	B2	0E	11	00	00	1C	00	00	00	FD	00
0x06	4B	1C	53	0F	00	0A	20	20	20	20	20	20	00	00	FC
0x07	00	4D	32	32	38	57	41	0A	20	20	20	20	20	00	A4

2) DIGITAL DATA 256Byte

0x00	0x01	0x02	0x03	0x04	0x05	0x06	0x07	0x08	0x09	0x0A	0x0B	0x0C	0x0D	0x0E	0x0F
00	FF	FF	FF	FF	FF	FF	00	1E	6D	3D	56	01	01	01	01
0x01	01	10	01	03	80	2F	1E	78	EA	D4	25	A4	55	49	9B
0x02	13	50	54	A7	6B	80	81	80	81	40	71	4F	01	01	01
0x03	01	01	01	01	01	01	7C	2E	90	A0	60	1A	1E	40	30
0x04	36	00	B2	0E	11	00	00	1A	21	39	98	30	62	1A	27
0x05	68	B0	36	00	B2	0E	11	00	00	1C	00	00	00	FD	00
0x06	4B	1C	53	0F	00	0A	20	20	20	20	20	20	00	00	FC
0x07	00	4D	32	32	38	57	41	0A	20	20	20	20	20	00	64

4.9. HDCP SETTING

(High-Bandwidth Digital Contents Protection)

- 1) Connect D-sub Signal Cable to D-Sub Jack.
- 2) Input HDCP key with HDCP-key- in-program.
- 3) HDCP Key value is stored on EEPROM(AT24C64) which is E00~F20 addresses of 0xBC~0xBE page.

ADH	ADL	LEN
BC	00	128
BC	80	128
BE	00	33

- 4) AC off/ on and on HDCP button of MSPG925 and confirm whether picture is displayed or not of using MSPG925.
- 5) HDCP Key value is different among the sets.

4.10. Outgoing condition Configuration

- 1) After all function test., press IN-STOP Key by SVC Remote controller. And Make Ship Condition.
- 2) When pressing IN-STOP key by SVC remocon, Green and red LED are blinked alternatively. And then Automatically turn off. (Must not AC power OFF during blinking)

4.11. Internal pressure

- Confirm whether is normal or not when between power board's ac block and GND is impacted on 1.5kV(dc) or 2.2kV(dc) for one second.

4.12 Option data setting (SVC OSD setting)

(1) PAL Model

*M198WA(Change by Suffix) Tool Option 8065

	M198WA-BZH	REMARK
Resolution	1	WXGA+
Module	0	
TV	1	
SCART	1	
AV2	1	
COMPONENT	1	
PC-RGB	1	
DVI	1	
HDMI	0	

*M208WA/M228WA(Change by Suffix) Tool Option 8066

	M208WA-BZH / M228WA-BZH	REMARK
Resolution	2	WSXGA
Module	0	
TV	1	
SCART	1	
AV2	1	
COMPONENT	1	
PC-RGB	1	
DVI	1	
HDMI	0	

*M198WA/M208WA/M228WA(Change by Suffix) Area Option 00

No.	Item	Condition	Remark
Option1(6)			
1	200PR	0	0 : 200 PR Off 1 : 200 PR On
2	ACMS	1	0 : ACMS Off 1 : ACMS On
3	Text	1	TOP FLOF
4	CH+AU	0	0 : Except below area 1 : China, Australia
5	BOOSTER	0	
Option2(2)			
1	SYS	0	0 : BG/I/DK/L 1 : BG/I/DK/M
2	A2 ST	1	Acting FM-ST after checking Nicam
3	I II SAVE	0	0 : I II SAVE Off 1 : I II SAVE On
4	HDEV	0	0 : Except below area 1 : China
5	V-Curve	0	0 : Turbo Volume Off 1 : Turbo Volume On
6	MONO	0	
Option3(2)			
1	KEY-TYPE	2	2 : 8Key
Option 4(3)			
1	Default Lang (Language)	3	
2	Lang	0	Chesky,Dansk,Deutsch,English Español,Français,Italiano, Magyar,Nederlands,Norsk, Polski,Português, P Y C C R II Ï Romaneste,Suomi,Svenska
3	T- Lang	0	AUSTRIA,BULGARIA, CROATIA,CZECH, DENMARK, ESTONIA,FINLAND,FRANCE, GERMANY,GREECE, HUNGARY,ITALY,LATVIA, NETHERLANDS,NORWAY, POLAND,PORTUGAL, RUMANIA,RUSSIA,SERBIA, SLOVAKIA,SLOVENIA,SPAIN, SWEDEN,SWITZERLAND, TURKEY,UK,ARAB,HEBREW, Others
Option5(9)			
1	2HR-OFF	1	0 : 2 Hour off option -OFF 1 : 2 Hour off option -ON
2	TV-LINK-TUNER	0	
3	FACTORY-MODE	0	0 : EEPROM Write Protection On 1 : EEPROM Write Protection Off
4	CHANNEL-MUTE	1	

5. Adjustment Command

5.1. Adjustment Commands(LENGTH=84)

Adjustment Contents	CMD (hex)	ADR	VAL	Description
FACTORY ON	E0	00	00	Factory mode on
FACTORY OFF	E2	00	00	Factory mode off
EEPROM ALL INIT.	E4	00	00	EEPROM All clear
EEPROM Read	E7	00	00	EEPROM Read
EEPROM Write	E8	00	data	EEPROM Write by some values
COLOR SAVE (R/G/B cutoff, Drive, Contrast, Bright)	EB	00	00	Color Save
H POSITION	20	00	00 – 100	They have different range each mode, FOS Adjustment
V POSITION	30	00	00 – 100	
CLOCK	90	00	00 – 100	
PHASE	92	00	00 – 100	
R DRIVE	16	00	00 – FF	Drive adjustment
G DRIVE	18	00	00 – FF	
B DRIVE	1A	00	00 – FF	
R CUTOFF	80	00	00 – 7F	Offset adjustment
G CUTOFF	82	00	00 – 7F	
B CUTOFF	84	00	00 – 7F	
BRIGHT	10	00	00 – 3F	Bright adjustment
CONTRAST	12	00	00 - 64	
AUTO_COLOR_ADJUST	F1	00	02	Auto COLOR Adjustment
CHANGE_COLOR_TEMP	F2	00	0,1,2,3	0: COOL 1: NORMAL 2: WARM 3: USER
FACTORY_DEFAULT	F3	00	00	Factory mode off & II_SW is "1" & Input change to "TV"
AUTO_INPUT CHANGE	F4	00	0,1,2,4	0: TV 1: AV1 2: AV2 3: Component 4: RGB 5: DVI

5.2 EEPROM DATA READ

(1) Signal Table

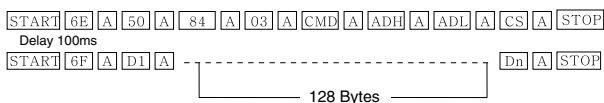

(2) Command Set

Adjustment contents	CMD(hex)	ADH(hex)	ADL(hex)	Details
EEPROM READ	E7	A0	0	0-Page 0~7F Read
			80	0-Page 80~FF Read
		A2	0	1-Page 0~7F Read
			80	1-Page 80~FF Read
		A4	0	2-Page 0~7F Read
			80	2-Page 80~FF Read
		A6	0	3-Page 0~7F Read
			80	3-Page 80~FF Read

* Purpose : To read the appointment Address of E2PROM by 128(80h)-byte

5.3. E2PROM Data Write

(1) Signal Table

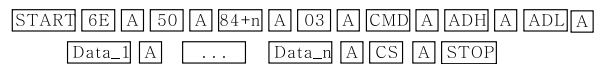

LEN : 84h+Bytes

CMD : 8Eh

ADH : E2PROM Slave Address(A0,A2,A4,A6,A8), Not 00h(Reserved by BufferToEEPROM)

ADL : E2PROM Sub Address(00~FF)

Data : Write data

(2) Command Set

Adjustment contents	CMD(hex)	ADH(hex)	Details
EEPROM WRITE	E8	94	16-Byte Write
		84+n	n-byte Write

* Purpose

- 1) EDID write : 16-byte by 16-byte, 8 order (128-byte) write(TO "00 – 7F" of "EEPROM Page A4").
- 2) FOS Default write : 16-mode data (HFh, HFI, VF, STD, HP, VP, Clk, ClkPh, PhFine) write.
- 3) Random Data write : write the appointment Address of E2PROM.

5.4. VRAM Read

- 1) Send CMD(70h) to read Video RAM value from MICOM And save its value to 128-Bytes Buffer(Common Buffer for the use of EDID)

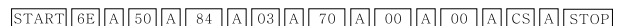

- 2) Delay 500ms (Time to Wait and Read Video RAM from MICOM)

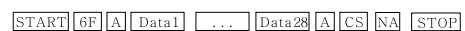

- 3) Be transmitted the contents of MICOM's 128-bytes Buffer to PC. (128th Data is the CheckSum of 127-bytes data : That's OK if the value of adding 128-bytes Data is Zero)

SERVICE OSD

BLUEBIRD3 - LP69G	
Version	2.01 061227
M228WA WSXGA	CMO-22W
UTT	0
<hr/>	
Tool Option	8066
Area Option	04
OPTION 1	6
OPTION 2	2
OPTION 3	2
OPTION 4	3
OPTION 5	9
RAM Delay	
Power Off History	
ETC	

■ Description of operation

- Tool Option : Adjust Tool Option
- Area Option : Adjust Area Option
- Option 1 : Adjust Tuner Service Option
- Option 2 : Adjust Sound Service Option
- Option 3 : Adjust Local key
- Option 4 : Select default language
- Option 5 : Adjust ETC
- RAM Delay : Adjust RAM Delay
- Power Off History : Adjust Power Off History
- ETC

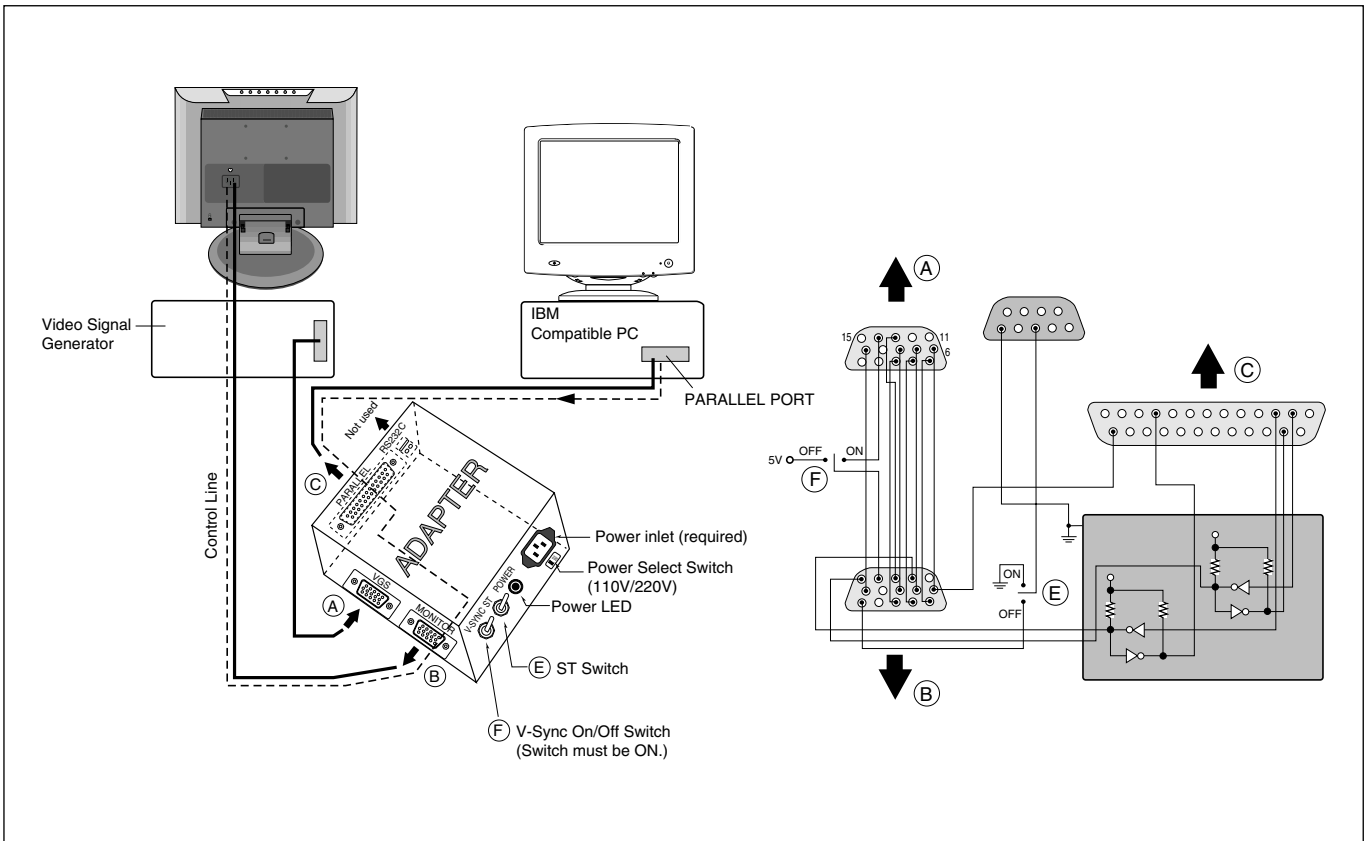
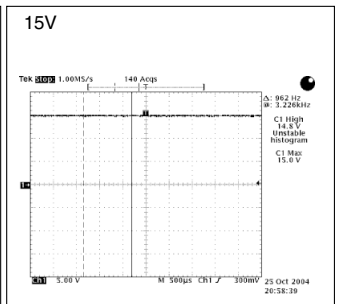
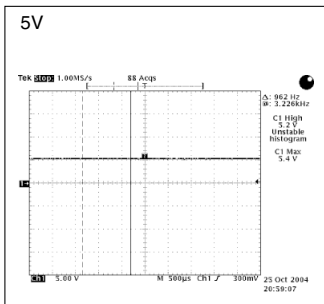
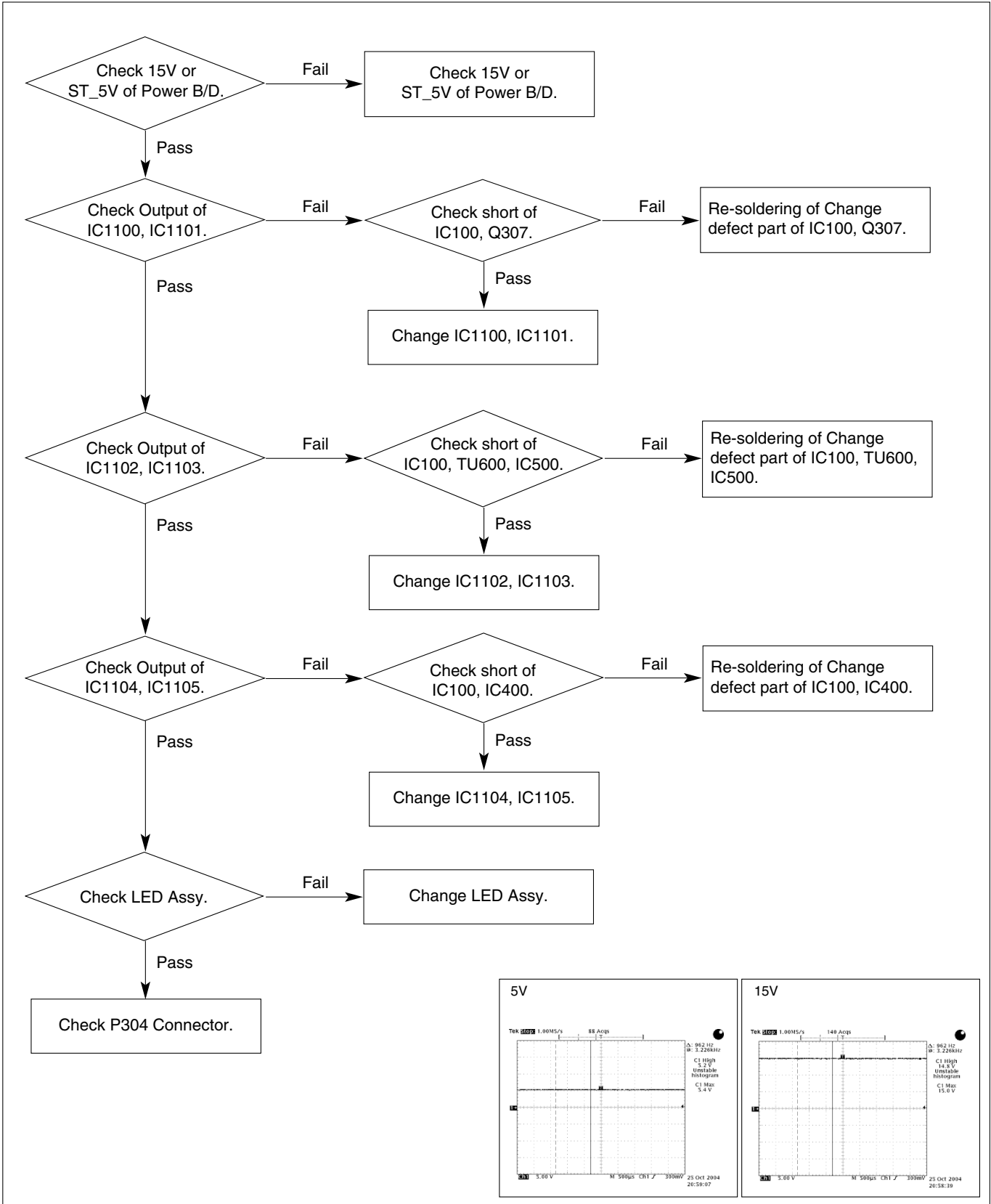

Figure 1. Cable Connection

TROUBLESHOOTING GUIDE

1. NO POWER (LED INDICATOR OFF) : [A] Process



2. NO RASTER : [B] Process

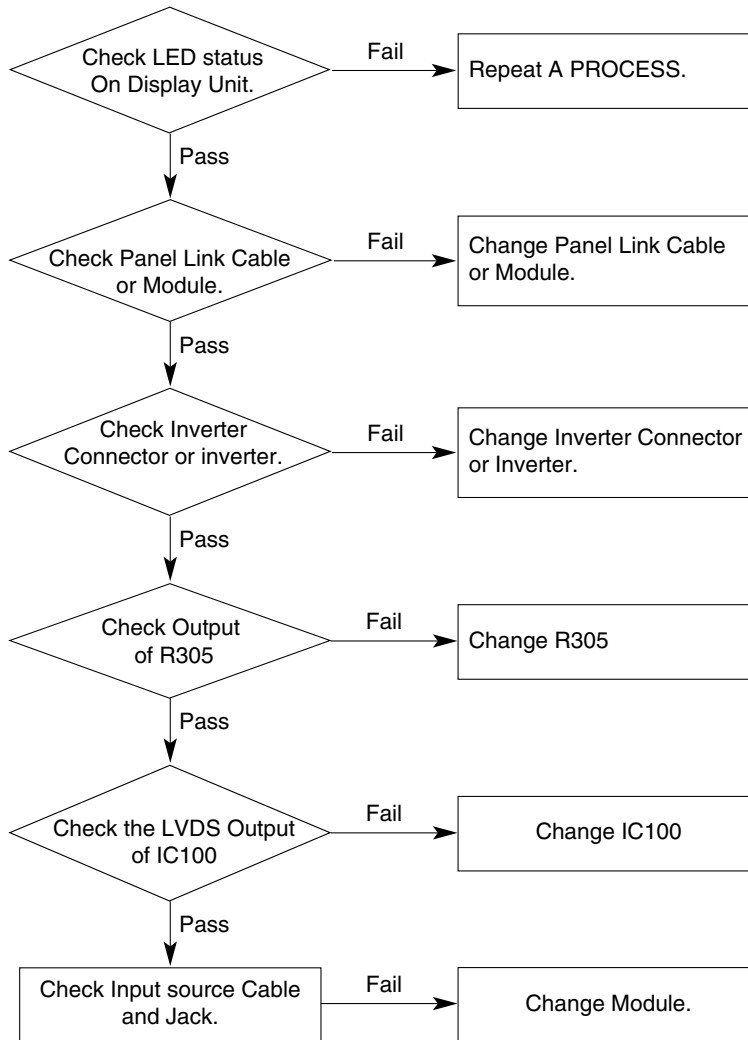

3. NO RASTER ON RGB SIGNAL

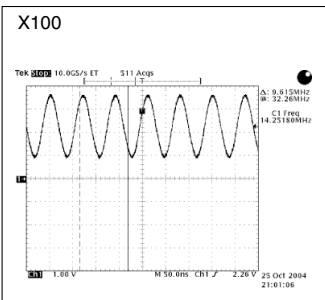
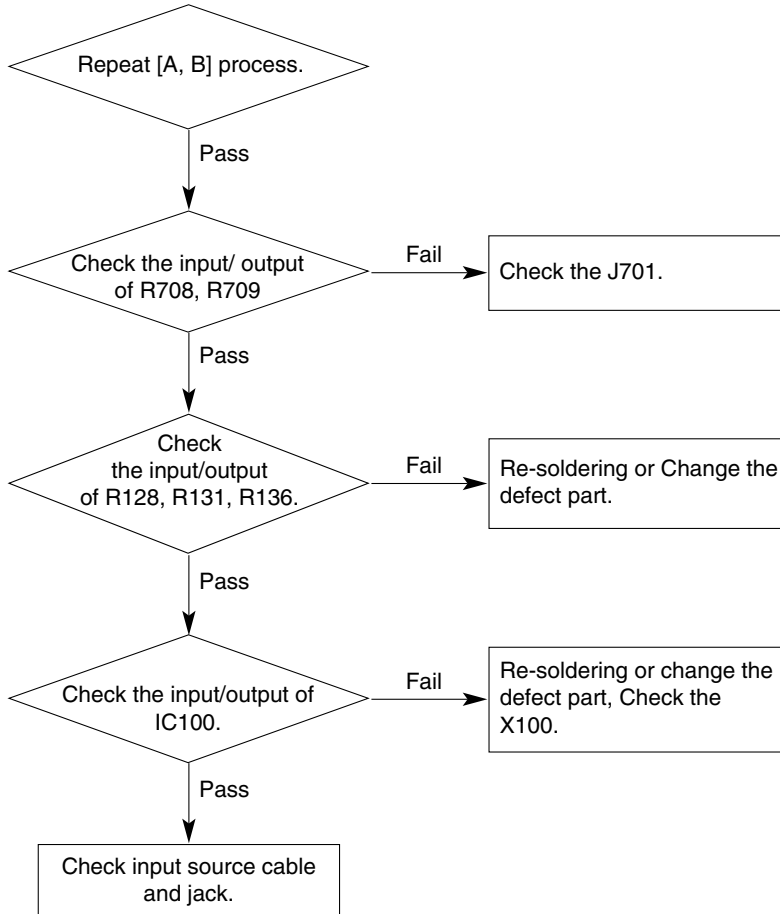

4. No Raster on Component Signal

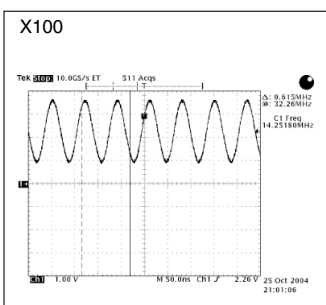
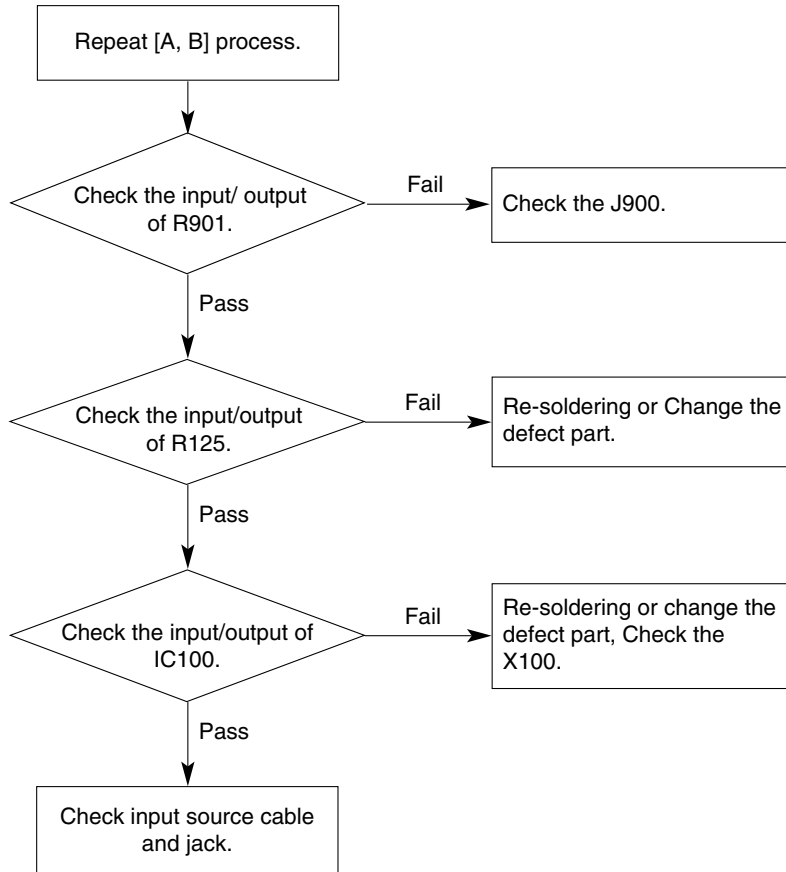

5. No Raster on DVI Signal

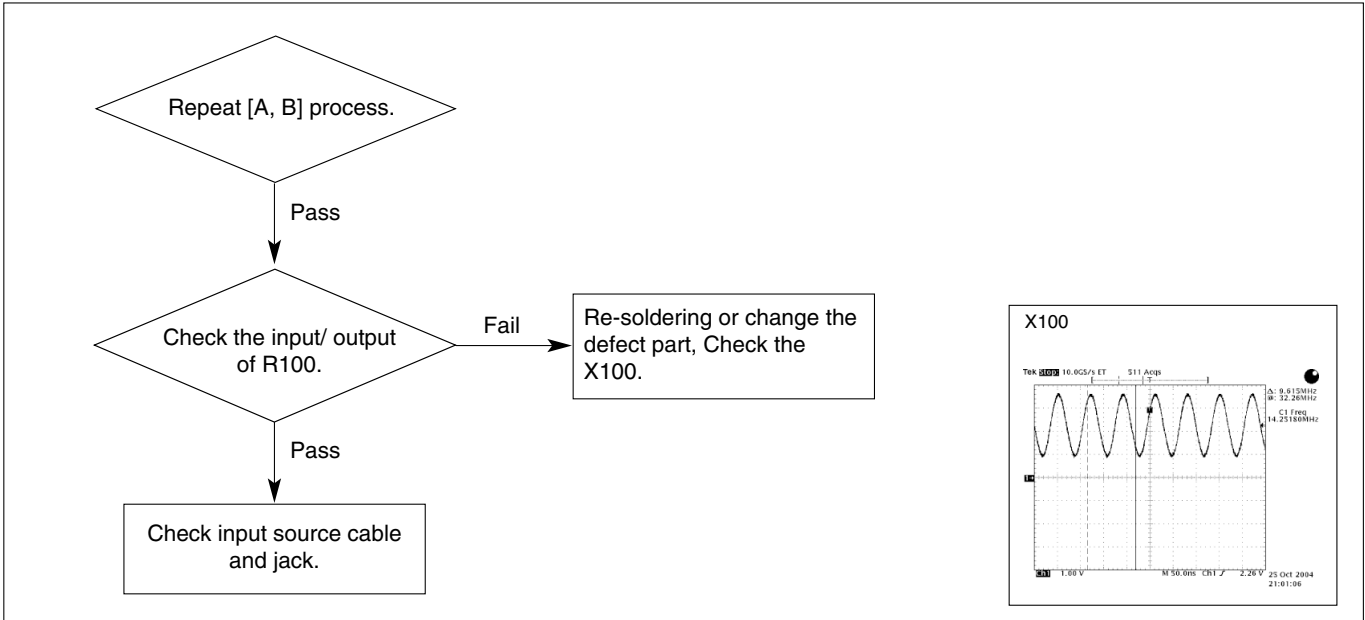

6. No Raster on AV(Scart in Video, S-Video) Signal

7. No Raster on TV(RF) Signal

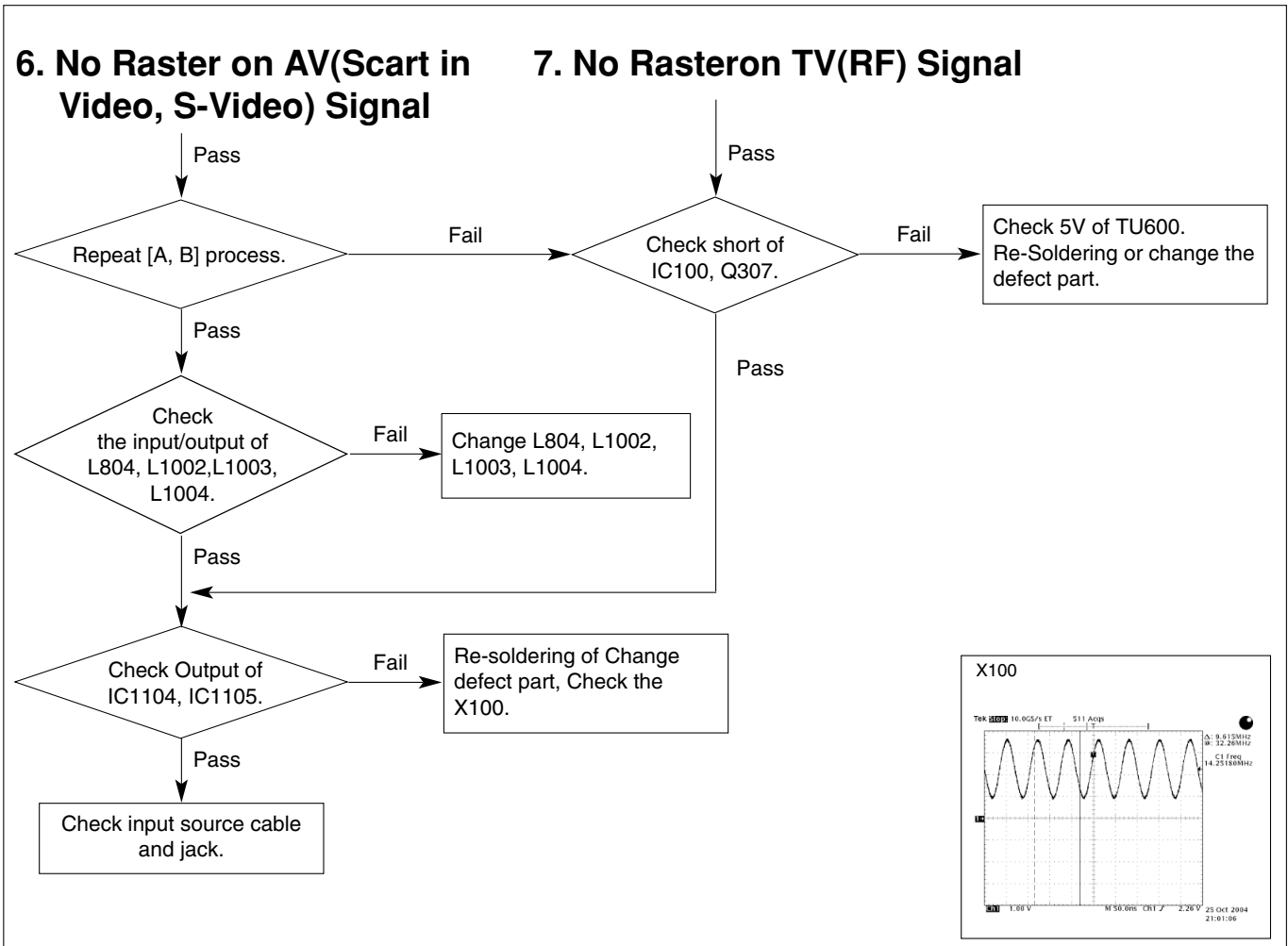

8. No sound

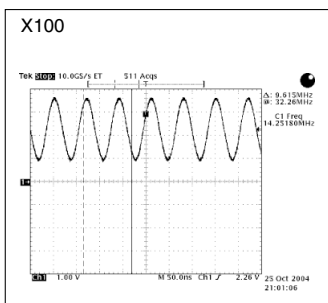
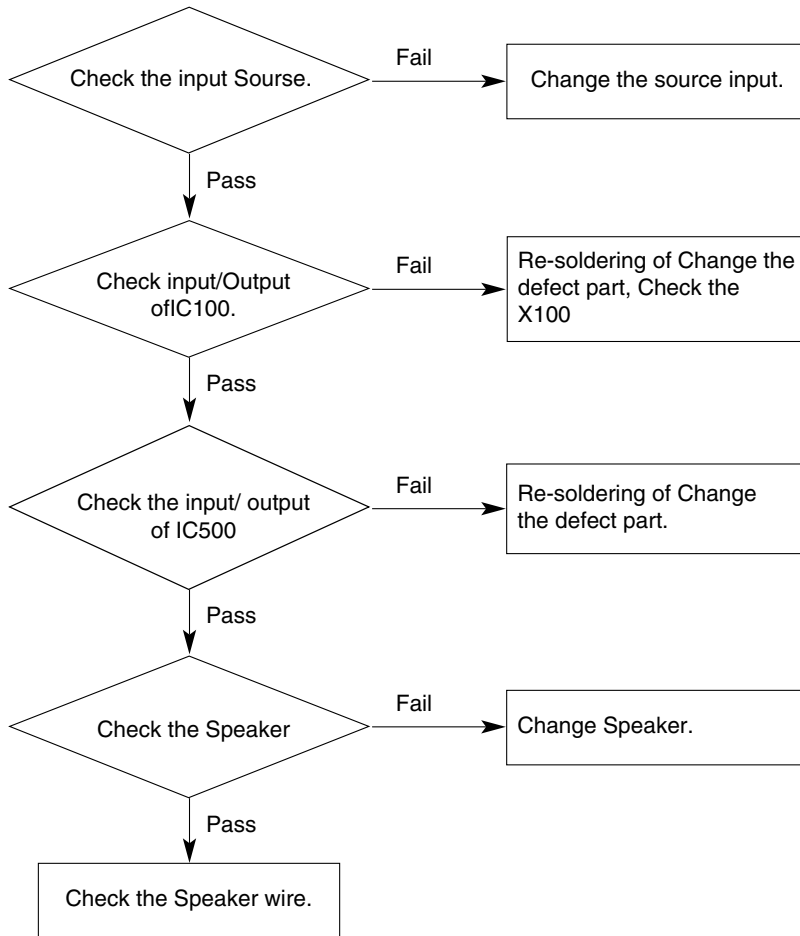



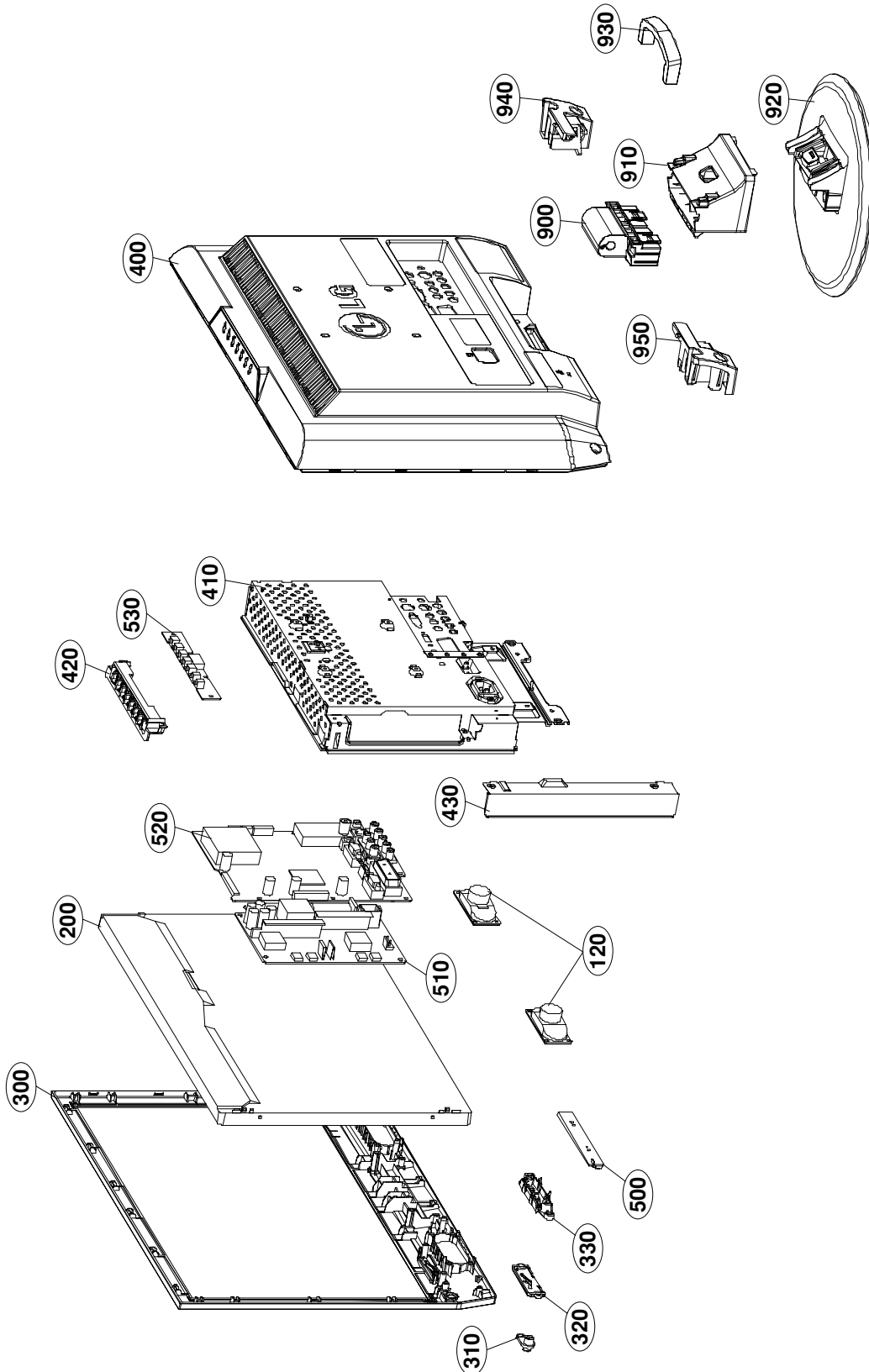



EXPLODED VIEW



EXPLODED VIEW PARTS LIST

* Note: Safety mark 

Ref. No.	Part No.	Description
120	EAB32761501	Speaker,Full Range, L07030A-027 ND35 3W 16OHM 85DB 300HZ 30 X 70 X 22 SOLDER SUNLINK COMPANY
200	 EAJ33527501	LCD,Module-TFT, M220Z1-L01 ZBD DRIVER 22.0INCH 1680X1050 300CD COLOR 72% 16/10 700:1 4CCFL, 2CH-LVDS, 5MS, 170/160 CHI MEI OPTOELECTRONICS CORP
	or EAJ33527502	LCD,Module-TFT, M220Z1-L01 NON-ZBD DRIVER 22.0INCH 1680X1050 300CD COLOR 72% 16/10 700:1 4CCFL, 2CH-LVDS, 5MS, 170/160 CHI MEI OPTOELECTRONICS CORP
300	 ABJ32411702	Cabinet Assembly, M228WA M228WA_CABINET ASS'Y ETC M228WA CABINET ASS'Y (22") _ CKD
310	MES35944701	Indicator, MOLD PMMA NON MX8W PMMA NON MX8W Model IR lens
320	MES35721501	Indicator, MOLD PMMA LED M198W PMMA NON M198W LED LENS
330	MBG35721401	Button, MOLD ABS HF-350 POWER M198W ABS 1KEY M198W POWER KNOB (BK)
400	 ACQ32411805	Cover Assembly,Rear, M228WA M228WA BACK_COVER ASS'Y 21" M228WA BACK_COVER ASS'Y(22" _PAL CKD)
410	ADV31008032	Frame Assembly, M228WA . ETC M228W METAL FRAME ASSY BB3 _ PAL [CKD]
420	MEY35721301	Knob, MOLD ABS HF-350 SUB 7KEY M198W M198W TACT KNOB BK
430	MGJ35722502	Plate,Shield, PRESS SBHG 0.6T FRAME EGI M8W LAMP WIRE SHIELD (0.3T) CKD
500	EBR35410101	PCB Assembly,Sub, LED & P/SW T.T LP69G M198WA/M208WA/M228WA AEUGLPX BRAND
510	 6871TPT318G	PCB Assembly,Power, PLLM-M602B POWER T.T CMO L225W 22"Wide Scaler Dimming FREQUENCY CHANGE LG INNOTEK CO., LTD
520	EBU35388003	Main Total Assembly, M228WA BRAND LP69G
530	EBR35409501	PCB Assembly,Sub, CONTROL T.T LP69G M198WA/M208WA/M228WA AEUGLPX BRAND
900	 AAN31022507	Base Assembly, STAND M198W/19LS4R CL81 M198WA/19LS4R/M208W HINGE COVER ASSY CKD
910	 MAZ35721602	Bracket, MOLD ABS HF-350 COVER M198W - ABS M198W/M208W/M228W STAND BODY (BLACK)=>CKD
920	 AAN32323504	Base Assembly, BASE M228W - M228W BASE ASS'Y CKD
930	MCK30233401	Cover, MOLD HIPS 51SF LS1R HIPS 51SF LS1R-holder cable management
940	MCK30246601	Cover, MOLD ABS 380 15LS1R ABS, HF-380 15LS1R-Cover hinge L
950	MCK30246901	Cover, MOLD ABS 380 15LS1R ABS, HF-380 15LS1R Cover hinge R

REPLACEMENT PARTS LIST

DATE: 2007. 01. 16.

LOC. NO.	PART NO.	DESCRIPTION / SPECIFICATION	LOC. NO.	PART NO.	DESCRIPTION / SPECIFICATION
CAPACITOR					
C1001	0CC331CK41A	C1608C0G1H331JT 330pF 5% 50V C0G	C1129	0CE227WF6DC	MVK8.0TP16VC220M 220uF 20% 16V 8
C1002	0CC331CK41A	C1608C0G1H331JT 330pF 5% 50V C0G	C1130	0CK104CK56A	0603B104K500CT 100nF 10% 50V X7R
C1003	0CC331CK41A	C1608C0G1H331JT 330pF 5% 50V C0G	C1131	0CK225DD66A	LMK212JB225MG-T 2.2uF 20% 10V X7
C1004	0CC331CK41A	C1608C0G1H331JT 330pF 5% 50V C0G	C1133	0CK104CK56A	0603B104K500CT 100nF 10% 50V X7R
C1005	0CC561CK41A	C1608C0G1H561JT 560pF 5% 50V C0G	C114	0CK104CK56A	0603B104K500CT 100nF 10% 50V X7R
C1006	0CC561CK41A	C1608C0G1H561JT 560pF 5% 50V C0G	C1148	0CE475WJ6DC	MVK4.0TP35VC4.7M 4.7uF 20% 35V 1
C1007	0CC331CK41A	C1608C0G1H331JT 330pF 5% 50V C0G	C1149	0CK104CK56A	0603B104K500CT 100nF 10% 50V X7R
C1008	0CC561CK41A	C1608C0G1H561JT 560pF 5% 50V C0G	C1150	0CE107WF6DC	MVK6.3TP16VC100M 100uF 20% 16V 8
C1009	0CC331CK41A	C1608C0G1H331JT 330pF 5% 50V C0G	C1150	0CE227WF6DC	MVK8.0TP16VC220M 220uF 20% 16V 8
C101	0CK104CK56A	0603B104K500CT 100nF 10% 50V X7R	C1151	0CE107WF6DC	MVK6.3TP16VC100M 100uF 20% 16V 8
C1010	0CC331CK41A	C1608C0G1H331JT 330pF 5% 50V C0G	C116	0CK104CK56A	0603B104K500CT 100nF 10% 50V X7R
C1011	0CC561CK41A	C1608C0G1H561JT 560pF 5% 50V C0G	C117	0CK104CK56A	0603B104K500CT 100nF 10% 50V X7R
C1012	0CK563CK56A	C1608X7R1H563KT 56nF 10% 50V X7R	C118	0CK104CK56A	0603B104K500CT 100nF 10% 50V X7R
C1013	0CK563CK56A	C1608X7R1H563KT 56nF 10% 50V X7R	C119	0CE106WFKDC	MVK4.0TP16VC10M 10uF 20% 16V 16M
C1014	0CK473CK56A	C1608X7R1H473KT 47nF 10% 50V X7R	C121	0CK104CK56A	0603B104K500CT 100nF 10% 50V X7R
C103	0CK104CK56A	0603B104K500CT 100nF 10% 50V X7R	C122	0CK224CF56A	0603B224K160CT 220nF 10% 16V X7R
C104	0CK104CK56A	0603B104K500CT 100nF 10% 50V X7R	C123	0CC102CK41A	C1608C0G1H102JT 1nF 5% 50V C0G -
C105	0CK104CK56A	0603B104K500CT 100nF 10% 50V X7R	C124	0CK104CK56A	0603B104K500CT 100nF 10% 50V X7R
C106	0CC220CK41A	C1608C0G1H220JT 22pF 5% 50V C0G	C125	0CK104CK56A	0603B104K500CT 100nF 10% 50V X7R
C107	0CC220CK41A	C1608C0G1H220JT 22pF 5% 50V C0G	C126	0CC560CK41A	C1608C0G1H560JT 56pF 5% 50V C0G
C1100	0CE477EH618	KMG5.0TP25VB470M 470uF 20% 25V 4	C127	0CC560CK41A	C1608C0G1H560JT 56pF 5% 50V C0G
C1101	0CE107WF6DC	MVK6.3TP16VC100M 100uF 20% 16V 8	C128	0CK473CK56A	C1608X7R1H473KT 47nF 10% 50V X7R
C1102	0CK474DH56A	C2012X7R1E474KT 470nF 10% 25V X7	C129	0CK473CK56A	C1608X7R1H473KT 47nF 10% 50V X7R
C1104	0CE477EH618	KMG5.0TP25VB470M 470uF 20% 25V 4	C130	0CK473CK56A	C1608X7R1H473KT 47nF 10% 50V X7R
C1105	0CE477EH618	KMG5.0TP25VB470M 470uF 20% 25V 4	C131	0CK473CK56A	C1608X7R1H473KT 47nF 10% 50V X7R
C1106	0CK104CK56A	0603B104K500CT 100nF 10% 50V X7R	C132	0CK473CK56A	C1608X7R1H473KT 47nF 10% 50V X7R
C1108	0CE107WF6DC	MVK6.3TP16VC100M 100uF 20% 16V 8	C133	0CK473CK56A	C1608X7R1H473KT 47nF 10% 50V X7R
C1109	0CK104CK56A	0603B104K500CT 100nF 10% 50V X7R	C134	0CK473CK56A	C1608X7R1H473KT 47nF 10% 50V X7R
C1110	0CK474DH56A	C2012X7R1E474KT 470nF 10% 25V X7	C135	0CK473CK56A	C1608X7R1H473KT 47nF 10% 50V X7R
C1111	0CK474DH56A	C2012X7R1E474KT 470nF 10% 25V X7	C136	0CK473CK56A	C1608X7R1H473KT 47nF 10% 50V X7R
C1112	0CK103CK56A	0603B103K500CT 10nF 10% 50V X7R	C137	0CK473CK56A	C1608X7R1H473KT 47nF 10% 50V X7R
C1113	0CK103CK56A	0603B103K500CT 10nF 10% 50V X7R	C138	0CK473CK56A	C1608X7R1H473KT 47nF 10% 50V X7R
C1114	0CK104CK56A	0603B104K500CT 100nF 10% 50V X7R	C139	0CK473CK56A	C1608X7R1H473KT 47nF 10% 50V X7R
C1115	0CE107WF6DC	MVK6.3TP16VC100M 100uF 20% 16V 8	C140	0CK473CK56A	C1608X7R1H473KT 47nF 10% 50V X7R
C1116	0CK272CK46A	0603B272J500CT 2.7nF 10% 50V X7R	C141	0CC102CK41A	C1608C0G1H102JT 1nF 5% 50V C0G -
C1117	0CK104CK56A	0603B104K500CT 100nF 10% 50V X7R	C142	0CK473CK56A	C1608X7R1H473KT 47nF 10% 50V X7R
C1118	0CK272CK46A	0603B272J500CT 2.7nF 10% 50V X7R	C143	0CK473CK56A	C1608X7R1H473KT 47nF 10% 50V X7R
C1119	0CK104CK56A	0603B104K500CT 100nF 10% 50V X7R	C144	0CK473CK56A	C1608X7R1H473KT 47nF 10% 50V X7R
C112	0CK104CK56A	0603B104K500CT 100nF 10% 50V X7R	C145	0CK473CK56A	C1608X7R1H473KT 47nF 10% 50V X7R
C1120	0CE107WF6DC	MVK6.3TP16VC100M 100uF 20% 16V 8	C146	0CK102CK56A	0603B102K500CT 1nF 10% 50V X7R -
C1121	0CK226FF67A	EMK325BJ226MM-T 22uF 20% 16V X5R	C147	0CK473CK56A	C1608X7R1H473KT 47nF 10% 50V X7R
C1122	0CK226FF67A	EMK325BJ226MM-T 22uF 20% 16V X5R	C148	0CK473CK56A	C1608X7R1H473KT 47nF 10% 50V X7R
C1123	0CE227WF6DC	MVK8.0TP16VC220M 220uF 20% 16V 8	C149	0CK473CK56A	C1608X7R1H473KT 47nF 10% 50V X7R
C1124	0CE477EH618	KMG5.0TP25VB470M 470uF 20% 25V 4	C150	0CK473CK56A	C1608X7R1H473KT 47nF 10% 50V X7R
C1125	0CE107WF6DC	MVK6.3TP16VC100M 100uF 20% 16V 8	C151	0CK473CK56A	C1608X7R1H473KT 47nF 10% 50V X7R
C1126	0CE227WF6DC	MVK8.0TP16VC220M 220uF 20% 16V 8	C152	0CK473CK56A	C1608X7R1H473KT 47nF 10% 50V X7R
C1127	0CK104CK56A	0603B104K500CT 100nF 10% 50V X7R	C153	0CK473CK56A	C1608X7R1H473KT 47nF 10% 50V X7R
C1128	0CK104CK56A	0603B104K500CT 100nF 10% 50V X7R	C154	0CK473CK56A	C1608X7R1H473KT 47nF 10% 50V X7R
			C155	0CK473CK56A	C1608X7R1H473KT 47nF 10% 50V X7R

LOC. NO.	PART NO.	DESCRIPTION / SPECIFICATION
C156	0CK473CK56A	C1608X7R1H473KT 47nF 10% 50V X7R
C157	0CC561CK41A	C1608C0G1H561JT 560pF 5% 50V C0G
C158	0CK104CK56A	0603B104K500CT 100nF 10% 50V X7R
C159	0CE106WFKDC	MVK4.0TP16VC10M 10uF 20% 16V 16M
C160	0CK104CK56A	0603B104K500CT 100nF 10% 50V X7R
C161	0CC561CK41A	C1608C0G1H561JT 560pF 5% 50V C0G
C162	0CK104CK56A	0603B104K500CT 100nF 10% 50V X7R
C163	0CK475CC94A	C1608Y5V0J475ZT 4.7uF -20TO+80%
C164	0CK105CD56A	C1608X7R1A105KT 1uF 10% 10V X7R
C165	0CK225DD66A	LMK212JB225MG-T 2.2uF 20% 10V X7
C166	0CK225DD66A	LMK212JB225MG-T 2.2uF 20% 10V X7
C167	0CK104CK56A	0603B104K500CT 100nF 10% 50V X7R
C168	0CK225DD66A	LMK212JB225MG-T 2.2uF 20% 10V X7
C169	0CK225DD66A	LMK212JB225MG-T 2.2uF 20% 10V X7
C170	0CK225DD66A	LMK212JB225MG-T 2.2uF 20% 10V X7
C171	0CK225DD66A	LMK212JB225MG-T 2.2uF 20% 10V X7
C172	0CK225DD66A	LMK212JB225MG-T 2.2uF 20% 10V X7
C173	0CK103CK56A	0603B103K500CT 10nF 10% 50V X7R
C174	0CK225DD66A	LMK212JB225MG-T 2.2uF 20% 10V X7
C175	0CK225DD66A	LMK212JB225MG-T 2.2uF 20% 10V X7
C176	0CK225DD66A	LMK212JB225MG-T 2.2uF 20% 10V X7
C177	0CK104CK56A	0603B104K500CT 100nF 10% 50V X7R
C178	0CK104CK56A	0603B104K500CT 100nF 10% 50V X7R
C179	0CK103CK56A	0603B103K500CT 10nF 10% 50V X7R
C180	0CK103CK56A	0603B103K500CT 10nF 10% 50V X7R
C181	0CK104CK56A	0603B104K500CT 100nF 10% 50V X7R
C182	0CK104CK56A	0603B104K500CT 100nF 10% 50V X7R
C183	0CK104CK56A	0603B104K500CT 100nF 10% 50V X7R
C185	0CK104CK56A	0603B104K500CT 100nF 10% 50V X7R
C186	0CK104CK56A	0603B104K500CT 100nF 10% 50V X7R
C187	0CK104CK56A	0603B104K500CT 100nF 10% 50V X7R
C188	0CK104CK56A	0603B104K500CT 100nF 10% 50V X7R
C189	0CK104CK56A	0603B104K500CT 100nF 10% 50V X7R
C190	0CK104CK56A	0603B104K500CT 100nF 10% 50V X7R
C191	0CK104CK56A	0603B104K500CT 100nF 10% 50V X7R
C192	0CC102CK41A	C1608C0G1H102JT 1nF 5% 50V C0G -
C193	0CK104CK56A	0603B104K500CT 100nF 10% 50V X7R
C194	0CK104CK56A	0603B104K500CT 100nF 10% 50V X7R
C195	0CK104CK56A	0603B104K500CT 100nF 10% 50V X7R
C196	0CK104CK56A	0603B104K500CT 100nF 10% 50V X7R
C197	0CK104CK56A	0603B104K500CT 100nF 10% 50V X7R
C198	0CK104CK56A	0603B104K500CT 100nF 10% 50V X7R
C199	0CE106WFKDC	MVK4.0TP16VC10M 10uF 20% 16V 16M
C200	0CK104CK56A	0603B104K500CT 100nF 10% 50V X7R
C202	0CK104CK56A	0603B104K500CT 100nF 10% 50V X7R
C204	0CK104CK56A	0603B104K500CT 100nF 10% 50V X7R
C205	0CK104CK56A	0603B104K500CT 100nF 10% 50V X7R
C206	0CK225DD66A	LMK212JB225MG-T 2.2uF 20% 10V X7
C301	0CE107WF6DC	MVK6.3TP16VC100M 100uF 20% 16V 8
C302	0CK103CK56A	0603B103K500CT 10nF 10% 50V X7R
C303	0CC101CK41A	C1608C0G1H101JT 100pF 5% 50V C0G
C304	0CC101CK41A	C1608C0G1H101JT 100pF 5% 50V C0G
C305	0CC101CK41A	C1608C0G1H101JT 100pF 5% 50V C0G
C306	0CC470CK41A	C1608C0G1H470JT 47pF 5% 50V C0G

LOC. NO.	PART NO.	DESCRIPTION / SPECIFICATION
C307	0CC101CK41A	C1608C0G1H101JT 100pF 5% 50V C0G
C308	0CC101CK41A	C1608C0G1H101JT 100pF 5% 50V C0G
C309	0CE107WF6DC	MVK6.3TP16VC100M 100uF 20% 16V 8
C310	0CE107WF6DC	MVK6.3TP16VC100M 100uF 20% 16V 8
C311	0CE107WF6DC	MVK6.3TP16VC100M 100uF 20% 16V 8
C312	0CE107WF6DC	MVK6.3TP16VC100M 100uF 20% 16V 8
C400	0CK104CK56A	0603B104K500CT 100nF 10% 50V X7R
C4000	0CN1040K949	CH UP050 F104Z-B-B Z 100nF -20TO
C4001	0CN1040K949	CH UP050 F104Z-B-B Z 100nF -20TO
C401	0CK104CK56A	0603B104K500CT 100nF 10% 50V X7R
C402	0CK104CK56A	0603B104K500CT 100nF 10% 50V X7R
C403	0CK104CK56A	0603B104K500CT 100nF 10% 50V X7R
C404	0CK104CK56A	0603B104K500CT 100nF 10% 50V X7R
C405	0CK104CK56A	0603B104K500CT 100nF 10% 50V X7R
C406	0CK104CK56A	0603B104K500CT 100nF 10% 50V X7R
C407	0CC102CK41A	C1608C0G1H102JT 1nF 5% 50V C0G -
C408	0CK104CK56A	0603B104K500CT 100nF 10% 50V X7R
C409	0CK104CK56A	0603B104K500CT 100nF 10% 50V X7R
C500	0CK225DH94A	C2012Y5V225ZFT 2.2uF -20TO+80% 2
C501	0CE476WH6DC	MVK8.0TP25VC47M 47uF 20% 25V 80M
C502	0CK224CF56A	0603B224K160CT 220nF 10% 16V X7R
C502	0CK103CK56A	0603B103K500CT 10nF 10% 50V X7R
C503	0CK224CF56A	0603B224K160CT 220nF 10% 16V X7R
C503	0CK103CK56A	0603B103K500CT 10nF 10% 50V X7R
C504	0CK474DH56A	C2012X7R1E474KT 470nF 10% 25V X7
C505	0CK105CD56A	C1608X7R1A105KT 1uF 10% 10V X7R
C506	0CE107WF6DC	MVK6.3TP16VC100M 100uF 20% 16V 8
C507	0CK475EF56A	C3216X7R1C475KT 4.7uF 10% 16V X7
C508	0CK475EF56A	C3216X7R1C475KT 4.7uF 10% 16V X7
C509	0CK105CD56A	C1608X7R1A105KT 1uF 10% 10V X7R
C510	0CE337WH6DC	MVK10TP25VC330M 330uF 20% 25V 45
C511	0CK475EF56A	C3216X7R1C475KT 4.7uF 10% 16V X7
C512	0CK105DH56A	C2012X7R105KFT 1uF 10% 25V X7R -
C513	0CE337WH6DC	MVK10TP25VC330M 330uF 20% 25V 45
C514	0CK475EF56A	C3216X7R1C475KT 4.7uF 10% 16V X7
C515	0CK104CK56A	0603B104K500CT 100nF 10% 50V X7R
C516	0CE106WFKDC	MVK4.0TP16VC10M 10uF 20% 16V 16M
C517	0CK105CD56A	C1608X7R1A105KT 1uF 10% 10V X7R
C518	0CC102CK41A	C1608C0G1H102JT 1nF 5% 50V C0G -
C519	0CK104CK56A	0603B104K500CT 100nF 10% 50V X7R
C520	0CC102CK41A	C1608C0G1H102JT 1nF 5% 50V C0G -
C521	0CK474DH56A	C2012X7R1E474KT 470nF 10% 25V X7
C522	0CK224CF56A	0603B224K160CT 220nF 10% 16V X7R
C522	0CK103CK56A	0603B103K500CT 10nF 10% 50V X7R
C523	0CK224CF56A	0603B224K160CT 220nF 10% 16V X7R
C523	0CK103CK56A	0603B103K500CT 10nF 10% 50V X7R
C524	0CC102CK41A	C1608C0G1H102JT 1nF 5% 50V C0G -
C525	0CC102CK41A	C1608C0G1H102JT 1nF 5% 50V C0G -
C526	0CC102CK41A	C1608C0G1H102JT 1nF 5% 50V C0G -
C527	0CC102CK41A	C1608C0G1H102JT 1nF 5% 50V C0G -
C528	0CC102CK41A	C1608C0G1H102JT 1nF 5% 50V C0G -
C529	0CC102CK41A	C1608C0G1H102JT 1nF 5% 50V C0G -
C530	0CC102CK41A	C1608C0G1H102JT 1nF 5% 50V C0G -
C531	0CC102CK41A	C1608C0G1H102JT 1nF 5% 50V C0G -

LOC. NO.	PART NO.	DESCRIPTION / SPECIFICATION
C600	0CK103CK56A	0603B103K500CT 10nF 10% 50V X7R
C601	0CC390CK41A	C1608C0G1H390JT 39pF 5% 50V C0G
C602	0CK103CK56A	0603B103K500CT 10nF 10% 50V X7R
C603	0CC390CK41A	C1608C0G1H390JT 39pF 5% 50V C0G
C604	0CK103CK56A	0603B103K500CT 10nF 10% 50V X7R
C605	0CE107WF6DC	MVK6.3TP16VC100M 100uF 20% 16V 8
C606	0CE107WF6DC	MVK6.3TP16VC100M 100uF 20% 16V 8
C607	0CK273CK56A	0603B273K500CT 27nF 10% 50V X7R
C608	0CK273CK56A	0603B273K500CT 27nF 10% 50V X7R
C609	0CH5331K416	0805N331J500LT 330pF 5% 50V C0G
C701	0CC101CK41A	C1608C0G1H101JT 100pF 5% 50V C0G
C702	0CC680CK41A	C1608C0G1H680JT 68pF 5% 50V C0G
C703	0CC101CK41A	C1608C0G1H101JT 100pF 5% 50V C0G
C704	0CC680CK41A	C1608C0G1H680JT 68pF 5% 50V C0G
C705	0CK104CK56A	0603B104K500CT 100nF 10% 50V X7R
C706	0CC680CK41A	C1608C0G1H680JT 68pF 5% 50V C0G
C707	0CC680CK41A	C1608C0G1H680JT 68pF 5% 50V C0G
C708	0CK104CK56A	0603B104K500CT 100nF 10% 50V X7R
C708	0CK474CH94A	0603F474Z250CT 470nF -20TO+80% 2
C709	0CK104CK56A	0603B104K500CT 100nF 10% 50V X7R
C709	0CK474CH94A	0603F474Z250CT 470nF -20TO+80% 2
C710	0CK104CK56A	0603B104K500CT 100nF 10% 50V X7R
C710	0CK474CH94A	0603F474Z250CT 470nF -20TO+80% 2
C711	0CK104CK56A	0603B104K500CT 100nF 10% 50V X7R
C711	0CK474CH94A	0603F474Z250CT 470nF -20TO+80% 2
C712	0CK104CK56A	0603B104K500CT 100nF 10% 50V X7R
C712	0CK474CH94A	0603F474Z250CT 470nF -20TO+80% 2
C713	0CK104CK56A	0603B104K500CT 100nF 10% 50V X7R
C713	0CK474CH94A	0603F474Z250CT 470nF -20TO+80% 2
C714	0CK104CK56A	0603B104K500CT 100nF 10% 50V X7R
C714	0CK474CH94A	0603F474Z250CT 470nF -20TO+80% 2
C715	0CK104CK56A	0603B104K500CT 100nF 10% 50V X7R
C715	0CK474CH94A	0603F474Z250CT 470nF -20TO+80% 2
C716	0CK104CK56A	0603B104K500CT 100nF 10% 50V X7R
C717	0CK104CK56A	0603B104K500CT 100nF 10% 50V X7R
C718	0CK104CK56A	0603B104K500CT 100nF 10% 50V X7R
C719	0CK104CK56A	0603B104K500CT 100nF 10% 50V X7R
C720	0CK104CK56A	0603B104K500CT 100nF 10% 50V X7R
C807	0CC331CK41A	C1608C0G1H331JT 330pF 5% 50V C0G
C808	0CC331CK41A	C1608C0G1H331JT 330pF 5% 50V C0G
C809	0CC102CK41A	C1608C0G1H102JT 1nF 5% 50V C0G -
C810	0CC102CK41A	C1608C0G1H102JT 1nF 5% 50V C0G -
C811	0CE107WF6DC	MVK6.3TP16VC100M 100uF 20% 16V 8
C812	0CC220CK41A	C1608C0G1H220JT 22pF 5% 50V C0G
C813	0CC220CK41A	C1608C0G1H220JT 22pF 5% 50V C0G
C814	0CC220CK41A	C1608C0G1H220JT 22pF 5% 50V C0G
C815	0CC220CK41A	C1608C0G1H220JT 22pF 5% 50V C0G
C816	0CE106WFKDC	MVK4.0TP16VC10M 10uF 20% 16V 16M
C817	0CE106WFKDC	MVK4.0TP16VC10M 10uF 20% 16V 16M
C818	0CK104CK56A	0603B104K500CT 100nF 10% 50V X7R
C819	0CE106WH6DC	MVK5.0TP25VC10M 10uF 20% 25V 25M
C820	0CC331CK41A	C1608C0G1H331JT 330pF 5% 50V C0G
C821	0CE106WFKDC	MVK4.0TP16VC10M 10uF 20% 16V 16M
C822	0CK104CK56A	0603B104K500CT 100nF 10% 50V X7R

LOC. NO.	PART NO.	DESCRIPTION / SPECIFICATION
C823	0CC561CK41A	C1608C0G1H561JT 560pF 5% 50V C0G
C824	0CC561CK41A	C1608C0G1H561JT 560pF 5% 50V C0G
C829	0CE335WK6D8	MVK4.0TP50VC3.3M 3.3uF 20% 50V 1
C830	0CE335WK6D8	MVK4.0TP50VC3.3M 3.3uF 20% 50V 1
C831	0CK104CK56A	0603B104K500CT 100nF 10% 50V X7R
C832	0CE335WK6D8	MVK4.0TP50VC3.3M 3.3uF 20% 50V 1
C833	0CE335WK6D8	MVK4.0TP50VC3.3M 3.3uF 20% 50V 1
C834	0CK104CK56A	0603B104K500CT 100nF 10% 50V X7R
C835	0CK222CK56A	0603B222K500CT 2.2nF 10% 50V X7R
C836	0CK222CK56A	0603B222K500CT 2.2nF 10% 50V X7R
C837	0CK104CK56A	0603B104K500CT 100nF 10% 50V X7R
C838	0CK104CK56A	0603B104K500CT 100nF 10% 50V X7R
C900	0CC102CK41A	C1608C0G1H102JT 1nF 5% 50V C0G -
C901	0CC102CK41A	C1608C0G1H102JT 1nF 5% 50V C0G -
ZD1000	0CK473CK56A	C1608X7R1H473KT 47nF 10% 50V X7R
COILS & INDUCTORS		
L1002	0LC0233002A	"Inductor,Multilayer,Chip",FI-B2012-332KJT
L1003	0LC0233002A	"Inductor,Multilayer,Chip",FI-B2012-332KJT
L1004	0LC0233002A	"Inductor,Multilayer,Chip",FI-B2012-332KJT
L1103	61409B0002A	"Coil,Choke",DBF-1030A 30uH - 2.5A
L1104	61409B0002A	"Coil,Choke",DBF-1030A 30uH - 2.5A
L500	61409B0002A	"Coil,Choke",DBF-1030A 30uH - 2.5A
L501	61409B0002A	"Coil,Choke",DBF-1030A 30uH - 2.5A
L503	61409B0002A	"Coil,Choke",DBF-1030A 30uH - 2.5A
L504	61409B0002A	"Coil,Choke",DBF-1030A 30uH - 2.5A
CONNECTORS & WAFERS		
C1	6631900109A	"Harness,Single", (FOOSUNG)DCE153B-
C2	6631T20023A	"Harness,Single", SMH200-11 SMH200-11
C3	6631900022P	"Harness,Single", SMH200-3P SMH200-3P
C4	6631900011H	"Harness,Single", SMH200 SMH200 450mM
J701	6630TGA004H	"Connector,DSUB",KCN-DS-0-0089 D-SUB
P1101	6602T20008K	"Connector,Wafer",SMW200-11P 11P 2.00MM
P1104	6630TGA005J	"Connector,DSUB",QH01121-HWK-PF DVI
P2001	6602T20009E	"Connector,Wafer",SMAW200-06P 6P 2.00MM
P300	6630V90219A	"Connector,Wafer",SMW200-28C 28P 2.0MM
P304	6602T20009E	"Connector,Wafer",SMAW200-06P 6P 2.00MM
P306	6602T20009B	"Connector,Wafer",SMAW200-03P 3P 2.00MM
P4000	6602T20009B	"Connector,Wafer",SMAW200-03P 3P 2.00MM
P500	6602T20009C	"Connector,Wafer",SMAW200-04P 4P 2.00MM
DIODES		
D1101	0DR340009AA	MBRS340 525MV 40V 4A 0SEC 0F 0W
D1102	0DR340009AA	MBRS340 525MV 40V 4A 0SEC 0F 0W
D500	0DS181009AA	KDS181 1.2V 85V 300MA 2A 4NSEC 1
D501	0DS181009AA	KDS181 1.2V 85V 300MA 2A 4NSEC 1
D502	0DS181009AA	KDS181 1.2V 85V 300MA 2A 4NSEC 1
D701	0DS226009AA	KDS226 1.2V 85V 300MA 2A 4NSEC 1
D702	0DS226009AA	KDS226 1.2V 85V 300MA 2A 4NSEC 1
D703	0DS226009AA	KDS226 1.2V 85V 300MA 2A 4NSEC 1

LOC. NO.	PART NO.	DESCRIPTION / SPECIFICATION
D704	ODS226009AA	KDS226 1.2V 85V 300MA 2A 4NSEC 1
D705	ODS226009AA	KDS226 1.2V 85V 300MA 2A 4NSEC 1
D706	ODS226009AA	KDS226 1.2V 85V 300MA 2A 4NSEC 1
D707	ODS226009AA	KDS226 1.2V 85V 300MA 2A 4NSEC 1
D708	ODS226009AA	KDS226 1.2V 85V 300MA 2A 4NSEC 1
D709	ODS226009AA	KDS226 1.2V 85V 300MA 2A 4NSEC 1
D710	ODS226009AA	KDS226 1.2V 85V 300MA 2A 4NSEC 1
D711	ODS226009AA	KDS226 1.2V 85V 300MA 2A 4NSEC 1
D712	ODSON00138A	MMBD301LT1G 600MV 30V - - 1.5pF
D713	ODSON00138A	MMBD301LT1G 600MV 30V - - 1.5pF
D714	ODD184009AA	KDS184 KDS184 TP KEC - 85V - - -
D715	ODD184009AA	KDS184 KDS184 TP KEC - 85V - - -
ZD1000	ODZ560009GB	BZT52C5V6S-(F) 5.6V 5.2TO6V 40OH
ZD1005	ODZ560009GB	BZT52C5V6S-(F) 5.6V 5.2TO6V 40OH
ZD1006	ODZ560009GB	BZT52C5V6S-(F) 5.6V 5.2TO6V 40OH
ZD1007	ODZ560009GB	BZT52C5V6S-(F) 5.6V 5.2TO6V 40OH
ZD1008	ODZ560009GB	BZT52C5V6S-(F) 5.6V 5.2TO6V 40OH
ZD1009	ODZ560009GB	BZT52C5V6S-(F) 5.6V 5.2TO6V 40OH
ZD1010	ODZ560009GB	BZT52C5V6S-(F) 5.6V 5.2TO6V 40OH
ZD1011	ODZ560009GB	BZT52C5V6S-(F) 5.6V 5.2TO6V 40OH
ZD1013	ODZ560009GB	BZT52C5V6S-(F) 5.6V 5.2TO6V 40OH
ZD1014	ODZ560009GB	BZT52C5V6S-(F) 5.6V 5.2TO6V 40OH
ZD1015	ODZ560009GB	BZT52C5V6S-(F) 5.6V 5.2TO6V 40OH
ZD1016	ODZ560009GB	BZT52C5V6S-(F) 5.6V 5.2TO6V 40OH
ZD1017	ODZ560009GB	BZT52C5V6S-(F) 5.6V 5.2TO6V 40OH
ZD1018	ODZ560009GB	BZT52C5V6S-(F) 5.6V 5.2TO6V 40OH
ZD1019	ODZ560009GB	BZT52C5V6S-(F) 5.6V 5.2TO6V 40OH
ZD1020	ODZ560009GB	BZT52C5V6S-(F) 5.6V 5.2TO6V 40OH
ZD1021	ODZ560009GB	BZT52C5V6S-(F) 5.6V 5.2TO6V 40OH
ZD1034	ODZ560009GB	BZT52C5V6S-(F) 5.6V 5.2TO6V 40OH
ZD2001	ODZ560009AA	MTZJ5.6B 5.6V 5.45TO5.73V 40OHM
ZD4000	ODZ560009CF	MTZJ5.6B 5.6V 5.45TO5.73V 40OHM
ZD4001	ODZ560009CF	MTZJ5.6B 5.6V 5.45TO5.73V 40OHM
ZD701	ODZ560009GB	BZT52C5V6S-(F) 5.6V 5.2TO6V 40OH
ZD702	ODZ560009GB	BZT52C5V6S-(F) 5.6V 5.2TO6V 40OH
ZD703	ODZ560009GB	BZT52C5V6S-(F) 5.6V 5.2TO6V 40OH
ZD704	ODZ560009GB	BZT52C5V6S-(F) 5.6V 5.2TO6V 40OH
ZD705	ODZ560009GB	BZT52C5V6S-(F) 5.6V 5.2TO6V 40OH
ZD708	ODZ560009GB	BZT52C5V6S-(F) 5.6V 5.2TO6V 40OH
ZD709	ODZ560009GB	BZT52C5V6S-(F) 5.6V 5.2TO6V 40OH
ZD710	ODZ560009GB	BZT52C5V6S-(F) 5.6V 5.2TO6V 40OH
ZD801	ODZ560009GB	BZT52C5V6S-(F) 5.6V 5.2TO6V 40OH
ZD802	ODZ560009GB	BZT52C5V6S-(F) 5.6V 5.2TO6V 40OH
ZD803	ODZ560009GB	BZT52C5V6S-(F) 5.6V 5.2TO6V 40OH
ZD804	ODZ560009GB	BZT52C5V6S-(F) 5.6V 5.2TO6V 40OH
ZD805	ODZ560009GB	BZT52C5V6S-(F) 5.6V 5.2TO6V 40OH
ZD806	ODZ560009GB	BZT52C5V6S-(F) 5.6V 5.2TO6V 40OH
ZD807	ODZ560009GB	BZT52C5V6S-(F) 5.6V 5.2TO6V 40OH
ZD808	ODZ560009GB	BZT52C5V6S-(F) 5.6V 5.2TO6V 40OH
ZD809	ODZ560009GB	BZT52C5V6S-(F) 5.6V 5.2TO6V 40OH
ZD810	ODZ560009GB	BZT52C5V6S-(F) 5.6V 5.2TO6V 40OH
ZD811	ODZ560009GB	BZT52C5V6S-(F) 5.6V 5.2TO6V 40OH
ZD812	ODZ560009GB	BZT52C5V6S-(F) 5.6V 5.2TO6V 40OH
ZD813	ODZ560009GB	BZT52C5V6S-(F) 5.6V 5.2TO6V 40OH

LOC. NO.	PART NO.	DESCRIPTION / SPECIFICATION
ZD814	ODZ560009GB	BZT52C5V6S-(F) 5.6V 5.2TO6V 40OH
ZD815	ODZ560009GB	BZT52C5V6S-(F) 5.6V 5.2TO6V 40OH
ZD900	ODZ560009GB	BZT52C5V6S-(F) 5.6V 5.2TO6V 40OH
ZD901	ODZ560009GB	BZT52C5V6S-(F) 5.6V 5.2TO6V 40OH
ZD902	ODZ560009GB	BZT52C5V6S-(F) 5.6V 5.2TO6V 40OH
ZD903	ODZ560009GB	BZT52C5V6S-(F) 5.6V 5.2TO6V 40OH
ZD904	ODZ560009GB	BZT52C5V6S-(F) 5.6V 5.2TO6V 40OH
ZD905	ODZ560009GB	BZT52C5V6S-(F) 5.6V 5.2TO6V 40OH
ZD906	ODZ560009GB	BZT52C5V6S-(F) 5.6V 5.2TO6V 40OH
ZD907	ODZ560009GB	BZT52C5V6S-(F) 5.6V 5.2TO6V 40OH
FILTERS		
L1000	6210TCE001A	HB-1S2012-080JT 8OHM 2X1.25X1MM
L1001	6210TCE001A	HB-1S2012-080JT 8OHM 2X1.25X1MM
L1006	6210TCE001A	HB-1S2012-080JT 8OHM 2X1.25X1MM
L1007	6210TCE001A	HB-1S2012-080JT 8OHM 2X1.25X1MM
L1113	6210TCE001G	HH-1M3216-501JT 500OHM 3.2X1.6X1
L1114	6200J00005E	HH-1M2012-601JT 600OHM 2X1.25X1M
L1115	6210TCE001G	HH-1M3216-501JT 500OHM 3.2X1.6X1
L1116	6200J00005E	HH-1M2012-601JT 600OHM 2X1.25X1M
L1117	6200J00005E	HH-1M2012-601JT 600OHM 2X1.25X1M
L505	6210TCE001G	HH-1M3216-501JT 500OHM 3.2X1.6X1
L506	6210TCE001G	HH-1M3216-501JT 500OHM 3.2X1.6X1
L507	6210TCE001G	HH-1M3216-501JT 500OHM 3.2X1.6X1
L508	6210TCE001G	HH-1M3216-501JT 500OHM 3.2X1.6X1
L509	6210TCE001G	HH-1M3216-501JT 500OHM 3.2X1.6X1
L510	6210TCE001G	HH-1M3216-501JT 500OHM 3.2X1.6X1
L511	6210TCE001G	HH-1M3216-501JT 500OHM 3.2X1.6X1
L512	6210TCE001G	HH-1M3216-501JT 500OHM 3.2X1.6X1
L801	6210TCE001A	HB-1S2012-080JT 8OHM 2X1.25X1MM
L802	6210TCE001A	HB-1S2012-080JT 8OHM 2X1.25X1MM
L803	6210TCE001A	HB-1S2012-080JT 8OHM 2X1.25X1MM
L804	6210TCE001A	HB-1S2012-080JT 8OHM 2X1.25X1MM
L805	6200J00005E	HH-1M2012-601JT 600OHM 2X1.25X1M
L806	6200J00005E	HH-1M2012-601JT 600OHM 2X1.25X1M
L807	6200J00005E	HH-1M2012-601JT 600OHM 2X1.25X1M
L808	6210TCE001A	HB-1S2012-080JT 8OHM 2X1.25X1MM
L900	6210TCE001A	HB-1S2012-080JT 8OHM 2X1.25X1MM
L901	6210TCE001A	HB-1S2012-080JT 8OHM 2X1.25X1MM
ICs		
IC100	EAN33715804	"LGE9789AD-LF 300MVTO3.6V,300MVTO"
IC102	EAN35392003	M228WA-BZH Micom Ass'y
IC103	0IMMRAL026C	AT24C64AN-10SU-2.7 64KBIT 8192x8
IC1100	0IPRPSG025A	LD1086D2M33 4.9TO30V 3.3V - D2PA
IC1101	0IPMGSG016A	LD1086D2T18TR 3.4TO30V 1.8V - D2
IC1102	0IMCRMZ001A	"MP1583DN-Z,LF 4.75TO23V 21V 0W S"
IC1103	0IMCRMZ001A	"MP1583DN-Z,LF 4.75TO23V 21V 0W S"
IC1104	0IPMG00107A	AZ1117H-2.5TR/E1 15V 2.5V 0W SOT
IC1105	0IMCRRH001A	BA033FP-E2 4.3TO25V 3.3V 1W TO25
IC1106	EAN33594801	CS4352-CZZR 8.55TO12.6 3.13TO3.4
IC1107	0ISS780500H	KA78M05RTM 7TO20V 5V - DPAK R/TP

LOC. NO.	PART NO.	DESCRIPTION / SPECIFICATION
IC400	EAN32205201	HY5DU281622FTP-5 128MBIT 8 x 16b
IC500	EAN33643401	YDA138-EZ(D-3) 9TO13.5V 7mV 0.02
IC701	OIMMR00014A	M24C02-RMN6TP 2KBIT 256X8BIT 1.8
IC702	OIMMR00014A	M24C02-RMN6TP 2KBIT 256X8BIT 1.8
JACKS		
J1000	6612F00099A	PEJ024-01 1P 4P STRAIGHT TR 3.6M
J1001	6612J10003K	PPJ148-07 14.0MM 1RX3C STRAIGHT
J1002	6612F00024C	PSJ014-01 SOCKET 4P ANGLE DIP ST
J1003	6612F00099A	PEJ024-01 1P 4P STRAIGHT TR 3.6M
J900	6612J10031B	PPJ209-01 14.0MM 1RX3C ANGLE BK
P800	6612M00010A	PSC003-01 21P 21P/1C 3.81MM STRA
RESISTORS		
AR400	0RJ1000C687	RCA86TRJ100R 100OHM 5% 1/16W 4 S
AR401	0RJ1000C687	RCA86TRJ100R 100OHM 5% 1/16W 4 S
AR410	0RJ1000C687	RCA86TRJ100R 100OHM 5% 1/16W 4 S
AR411	0RJ1000C687	RCA86TRJ100R 100OHM 5% 1/16W 4 S
R1000	0RJ0752D477	MCR03EZPF750 75OHM 1% 1/10W 1608
R1001	0RJ0752D477	MCR03EZPF750 75OHM 1% 1/10W 1608
R1002	0RJ4703D677	MCR03EZPJ474 470KOHM 5% 1/10W 16
R1003	0RJ4703D677	MCR03EZPJ474 470KOHM 5% 1/10W 16
R1004	0RJ4703D677	MCR03EZPJ474 470KOHM 5% 1/10W 16
R1005	0RJ0752D477	MCR03EZPF750 75OHM 1% 1/10W 1608
R1006	0RJ1502D677	MCR03EZPJ153 15KOHM 5% 1/10W 160
R1007	0RJ1502D677	MCR03EZPJ153 15KOHM 5% 1/10W 160
R1008	0RJ4703D677	MCR03EZPJ474 470KOHM 5% 1/10W 16
R1009	0RJ9101D677	MCR03EZPJ912 9.1KOHM 5% 1/10W 16
R101	0RJ1004D477	MCR03EZPF105 1MOHM 1% 1/10W 1608
R1010	0RJ9101D677	MCR03EZPJ912 9.1KOHM 5% 1/10W 16
R1011	0RJ0752D477	MCR03EZPF750 75OHM 1% 1/10W 1608
R1012	0RJ1002D677	MCR03EZPJ103 10KOHM 5% 1/10W 160
R1013	0RJ1002D677	MCR03EZPJ103 10KOHM 5% 1/10W 160
R1014	0RJ0752D477	MCR03EZPF750 75OHM 1% 1/10W 1608
R1015	0RJ0752D477	MCR03EZPF750 75OHM 1% 1/10W 1608
R1016	0RJ1202D677	MCR03EZPJ123 12KOHM 5% 1/10W 160
R1017	0RJ1202D677	MCR03EZPJ123 12KOHM 5% 1/10W 160
R102	0RJ1000D677	MCR03EZPJ101 100OHM 5% 1/10W 160
R1021	0RJ0152D677	MCR03EZPJ150 15OHM 5% 1/10W 1608
R1021	0RJ0332D677	MCR03EZPJ330 33OHM 5% 1/10W 1608
R1022	0RJ0152D677	MCR03EZPJ150 15OHM 5% 1/10W 1608
R1022	0RJ0332D677	MCR03EZPJ330 33OHM 5% 1/10W 1608
R103	0RJ1000D677	MCR03EZPJ101 100OHM 5% 1/10W 160
R105	0RJ1201D677	MCR03EZPJ122 1.2KOHM 5% 1/10W 16
R106	0RJ1002D677	MCR03EZPJ103 10KOHM 5% 1/10W 160
R107	0RJ4700D677	MCR03EZPJ471 470OHM 5% 1/10W 160
R108	0RH0000D622	MCR10EZHJ000 0OHM 5% 1/8W 2012 R
R109	0RJ1000D677	MCR03EZPJ101 100OHM 5% 1/10W 160
R1103	0RJ1101D677	MCR03EZPJ112 1.1KOHM 5% 1/10W 16
R1104	0RJ1001D677	MCR03EZPJ102 1KOHM 5% 1/10W 1608
R1105	0RJ1000D677	MCR03EZPJ101 100OHM 5% 1/10W 160
R1106	0RJ1000D677	MCR03EZPJ101 100OHM 5% 1/10W 160

LOC. NO.	PART NO.	DESCRIPTION / SPECIFICATION
R1107	0RJ1002D677	MCR03EZPJ103 10KOHM 5% 1/10W 160
R111	0RJ0472D677	MCR03EZPJ470 470OHM 5% 1/10W 1608
R1110	0RJ1002D677	MCR03EZPJ103 10KOHM 5% 1/10W 160
R1111	0RJ6801D477	MCR03EZPF682 6.8KOHM 1% 1/10W 16
R1112	0RJ2202D477	MCR03EZPF223 22KOHM 1% 1/10W 160
R1113	0RJ1002D677	MCR03EZPJ103 10KOHM 5% 1/10W 160
R1114	0RJ1002D677	MCR03EZPJ103 10KOHM 5% 1/10W 160
R1115	0RJ6801D477	MCR03EZPF682 6.8KOHM 1% 1/10W 16
R1116	0RJ1053D477	MCR03EZPF1053 105KOHM 1% 1/10W 1
R1117	0RJ1002D677	MCR03EZPJ103 10KOHM 5% 1/10W 160
R1118	0RJ1002D677	MCR03EZPJ103 10KOHM 5% 1/10W 160
R112	0RJ0472D677	MCR03EZPJ470 470OHM 5% 1/10W 1608
R1122	0RJ1002D677	MCR03EZPJ103 10KOHM 5% 1/10W 160
R114	0RJ0472D677	MCR03EZPJ470 470OHM 5% 1/10W 1608
R1140	0RJ1000D677	MCR03EZPJ101 100OHM 5% 1/10W 160
R1141	0RJ1001D677	MCR03EZPJ102 1KOHM 5% 1/10W 1608
R1146	0RJ0102D677	MCR03EZPJ100 10OHM 5% 1/10W 1608
R1147	0RJ1000D677	MCR03EZPJ101 100OHM 5% 1/10W 160
R1147	0RJ3300D677	MCR03EZPJ331 330OHM 5% 1/10W 160
R1147	0RJ4700D677	MCR03EZPJ471 470OHM 5% 1/10W 160
R1149	0RJ1000D677	MCR03EZPJ101 100OHM 5% 1/10W 160
R115	0RJ0472D677	MCR03EZPJ470 470OHM 5% 1/10W 1608
R1150	0RX0102K665	RSD02F4J10R0 10OHM 5% 2W 12.0X4.
R1153	0RJ1053D477	MCR03EZPF1053 105KOHM 1% 1/10W 1
R116	0RJ0472D677	MCR03EZPJ470 470OHM 5% 1/10W 1608
R117	0RJ0472D677	MCR03EZPJ470 470OHM 5% 1/10W 1608
R118	0RJ0472D677	MCR03EZPJ470 470OHM 5% 1/10W 1608
R119	0RJ0472D677	MCR03EZPJ470 470OHM 5% 1/10W 1608
R120	0RJ0472D677	MCR03EZPJ470 470OHM 5% 1/10W 1608
R121	0RJ0472D677	MCR03EZPJ470 470OHM 5% 1/10W 1608
R122	0RJ0472D677	MCR03EZPJ470 470OHM 5% 1/10W 1608
R123	0RJ0472D677	MCR03EZPJ470 470OHM 5% 1/10W 1608
R124	0RJ4700D677	MCR03EZPJ471 470OHM 5% 1/10W 160
R125	0RJ0472D677	MCR03EZPJ470 470OHM 5% 1/10W 1608
R126	0RJ0472D677	MCR03EZPJ470 470OHM 5% 1/10W 1608
R127	0RJ1000D677	MCR03EZPJ101 100OHM 5% 1/10W 160
R128	0RJ0562D677	MCR03EZPJ560 56OHM 5% 1/10W 1608
R129	0RJ4700D677	MCR03EZPJ471 470OHM 5% 1/10W 160
R130	0RJ1000D677	MCR03EZPJ101 100OHM 5% 1/10W 160
R131	0RJ0562D677	MCR03EZPJ560 56OHM 5% 1/10W 1608
R132	0RJ0472D677	MCR03EZPJ470 470OHM 5% 1/10W 1608
R133	0RJ0472D677	MCR03EZPJ470 470OHM 5% 1/10W 1608
R134	0RJ0472D677	MCR03EZPJ470 470OHM 5% 1/10W 1608
R135	0RJ1000D677	MCR03EZPJ101 100OHM 5% 1/10W 160
R136	0RJ0562D677	MCR03EZPJ560 56OHM 5% 1/10W 1608
R137	0RJ0472D677	MCR03EZPJ470 470OHM 5% 1/10W 1608
R138	0RJ0472D677	MCR03EZPJ470 470OHM 5% 1/10W 1608
R139	0RJ0472D677	MCR03EZPJ470 470OHM 5% 1/10W 1608
R140	0RJ0000D677	MCR03EZPJ000 0OHM 5% 1/10W 1608
R141	0RJ0000D677	MCR03EZPJ000 0OHM 5% 1/10W 1608
R142	0RJ0000D677	MCR03EZPJ000 0OHM 5% 1/10W 1608
R143	0RJ4701D677	MCR03EZPJ472 4.7KOHM 5% 1/10W 16
R144	0RJ3900D677	MCR03EZPJ391 390OHM 5% 1/10W 160
R148	0RJ0000D677	MCR03EZPJ000 0OHM 5% 1/10W 1608

LOC. NO.	PART NO.	DESCRIPTION / SPECIFICATION
R153	0RJ1002D677	MCR03EZPJ103 10KOHM 5% 1/10W 160
R154	0RJ1202D677	MCR03EZPJ123 12KOHM 5% 1/10W 160
R155	0RJ1000D677	MCR03EZPJ101 100OHM 5% 1/10W 160
R156	0RJ1000D677	MCR03EZPJ101 100OHM 5% 1/10W 160
R157	0RJ0332D677	MCR03EZPJ330 33OHM 5% 1/10W 1608
R158	0RJ0332D677	MCR03EZPJ330 33OHM 5% 1/10W 1608
R159	0RJ1000D677	MCR03EZPJ101 100OHM 5% 1/10W 160
R162	0RJ1000D677	MCR03EZPJ101 100OHM 5% 1/10W 160
R163	0RJ1000D677	MCR03EZPJ101 100OHM 5% 1/10W 160
R165	0RJ1000D677	MCR03EZPJ101 100OHM 5% 1/10W 160
R166	0RJ1000D677	MCR03EZPJ101 100OHM 5% 1/10W 160
R167	0RJ1000D677	MCR03EZPJ101 100OHM 5% 1/10W 160
R168	0RJ1000D677	MCR03EZPJ101 100OHM 5% 1/10W 160
R173	0RJ2202D677	MCR03EZPJ223 22KOHM 5% 1/10W 160
R174	0RJ2202D677	MCR03EZPJ223 22KOHM 5% 1/10W 160
R183	0RJ1001D677	MCR03EZPJ102 1KOHM 5% 1/10W 1608
R184	0RJ1001D677	MCR03EZPJ102 1KOHM 5% 1/10W 1608
R185	0RJ1000D677	MCR03EZPJ101 100OHM 5% 1/10W 160
R186	0RJ1000D677	MCR03EZPJ101 100OHM 5% 1/10W 160
R187	0RJ1000D677	MCR03EZPJ101 100OHM 5% 1/10W 160
R190	0RJ1000D677	MCR03EZPJ101 100OHM 5% 1/10W 160
R191	0RJ1000D677	MCR03EZPJ101 100OHM 5% 1/10W 160
R192	0RJ1000D677	MCR03EZPJ101 100OHM 5% 1/10W 160
R193	0RJ1000D677	MCR03EZPJ101 100OHM 5% 1/10W 160
R194	0RJ1000D677	MCR03EZPJ101 100OHM 5% 1/10W 160
R196	0RJ1000D677	MCR03EZPJ101 100OHM 5% 1/10W 160
R198	0RJ0332D677	MCR03EZPJ330 33OHM 5% 1/10W 1608
R201	0RJ0332D677	MCR03EZPJ330 33OHM 5% 1/10W 1608
R202	0RJ1000D677	MCR03EZPJ101 100OHM 5% 1/10W 160
R203	0RJ1000D677	MCR03EZPJ101 100OHM 5% 1/10W 160
R204	0RJ3301D677	MCR03EZPJ332 3.3KOHM 5% 1/10W 16
R205	0RJ1000D677	MCR03EZPJ101 100OHM 5% 1/10W 160
R206	0RJ1000D677	MCR03EZPJ101 100OHM 5% 1/10W 160
R207	0RJ0332D677	MCR03EZPJ330 33OHM 5% 1/10W 1608
R208	0RJ0332D677	MCR03EZPJ330 33OHM 5% 1/10W 1608
R209	0RJ0332D677	MCR03EZPJ330 33OHM 5% 1/10W 1608
R212	0RJ0332D677	MCR03EZPJ330 33OHM 5% 1/10W 1608
R213	0RJ0332D677	MCR03EZPJ330 33OHM 5% 1/10W 1608
R214	0RJ0332D677	MCR03EZPJ330 33OHM 5% 1/10W 1608
R215	0RJ0332D677	MCR03EZPJ330 33OHM 5% 1/10W 1608
R216	0RJ0332D677	MCR03EZPJ330 33OHM 5% 1/10W 1608
R217	0RJ0332D677	MCR03EZPJ330 33OHM 5% 1/10W 1608
R218	0RJ0000D677	MCR03EZPJ000 0OHM 5% 1/10W 1608
R219	0RJ0000D677	MCR03EZPJ000 0OHM 5% 1/10W 1608
R223	0RJ0332D677	MCR03EZPJ330 33OHM 5% 1/10W 1608
R224	0RJ0332D677	MCR03EZPJ330 33OHM 5% 1/10W 1608
R225	0RJ1002D677	MCR03EZPJ103 10KOHM 5% 1/10W 160
R228	0RJ3301D677	MCR03EZPJ332 3.3KOHM 5% 1/10W 16
R229	0RJ1002D677	MCR03EZPJ103 10KOHM 5% 1/10W 160
R231	0RJ3301D677	MCR03EZPJ332 3.3KOHM 5% 1/10W 16
R232	0RJ3301D677	MCR03EZPJ332 3.3KOHM 5% 1/10W 16
R235	0RJ3301D677	MCR03EZPJ332 3.3KOHM 5% 1/10W 16
R238	0RJ1002D677	MCR03EZPJ103 10KOHM 5% 1/10W 160
R239	0RJ1000D677	MCR03EZPJ101 100OHM 5% 1/10W 160

LOC. NO.	PART NO.	DESCRIPTION / SPECIFICATION
R242	0RJ1001D677	MCR03EZPJ102 1KOHM 5% 1/10W 1608
R243	0RJ3301D677	MCR03EZPJ332 3.3KOHM 5% 1/10W 16
R245	0RJ4701D677	MCR03EZPJ472 4.7KOHM 5% 1/10W 16
R249	0RJ4701D677	MCR03EZPJ472 4.7KOHM 5% 1/10W 16
R250	0RJ4701D677	MCR03EZPJ472 4.7KOHM 5% 1/10W 16
R252	0RJ4701D677	MCR03EZPJ472 4.7KOHM 5% 1/10W 16
R253	0RJ1000D677	MCR03EZPJ101 100OHM 5% 1/10W 160
R254	0RJ1000D677	MCR03EZPJ101 100OHM 5% 1/10W 160
R256	0RJ1001D677	MCR03EZPJ102 1KOHM 5% 1/10W 1608
R259	0RJ1000D677	MCR03EZPJ101 100OHM 5% 1/10W 160
R260	0RJ1002D677	MCR03EZPJ103 10KOHM 5% 1/10W 160
R262	0RJ4701D677	MCR03EZPJ472 4.7KOHM 5% 1/10W 16
R263	0RJ0000D677	MCR03EZPJ000 0OHM 5% 1/10W 1608
R264	0RJ1002D677	MCR03EZPJ103 10KOHM 5% 1/10W 160
R267	0RJ0000D677	MCR03EZPJ000 0OHM 5% 1/10W 1608
R300	0RJ1002D677	MCR03EZPJ103 10KOHM 5% 1/10W 160
R302	0RJ1002D677	MCR03EZPJ103 10KOHM 5% 1/10W 160
R303	0RH2001D622	MCR10EZHJ202 2KOHM 5% 1/8W 2012
R304	0RH2001D622	MCR10EZHJ202 2KOHM 5% 1/8W 2012
R305	0RH0000D622	MCR10EZHJ000 0OHM 5% 1/8W 2012 R
R310	0RJ4701D677	MCR03EZPJ472 4.7KOHM 5% 1/10W 16
R311	0RJ4701D677	MCR03EZPJ472 4.7KOHM 5% 1/10W 16
R312	0RJ4701D677	MCR03EZPJ472 4.7KOHM 5% 1/10W 16
R313	0RJ4701D677	MCR03EZPJ472 4.7KOHM 5% 1/10W 16
R314	0RJ1002D677	MCR03EZPJ103 10KOHM 5% 1/10W 160
R315	0RJ1002D677	MCR03EZPJ103 10KOHM 5% 1/10W 160
R316	0RJ1002D677	MCR03EZPJ103 10KOHM 5% 1/10W 160
R319	0RH2001D622	MCR10EZHJ202 2KOHM 5% 1/8W 2012
R320	0RH2001D622	MCR10EZHJ202 2KOHM 5% 1/8W 2012
R4000	0RN6801F409	RN-96T1F6K80 6.8KOHM 1% 1/6W 3.2
R4001	0RN2201F409	RN-96T1F2K20 2.2KOHM 1% 1/6W 3.2
R4002	0RN1001F409	RN-96T1F1K00 1KOHM 1% 1/6W 3.2X1
R4003	0RN6801F409	RN-96T1F6K80 6.8KOHM 1% 1/6W 3.2
R4004	0RN2201F409	RN-96T1F2K20 2.2KOHM 1% 1/6W 3.2
R4005	0RN1001F409	RN-96T1F1K00 1KOHM 1% 1/6W 3.2X1
R402	0RJ1000D677	MCR03EZPJ101 100OHM 5% 1/10W 160
R403	0RJ1000D677	MCR03EZPJ101 100OHM 5% 1/10W 160
R404	0RJ0222D677	MCR03EZPJ220 22OHM 5% 1/10W 1608
R405	0RJ1000D677	MCR03EZPJ101 100OHM 5% 1/10W 160
R406	0RJ1500D677	MCR03EZPJ151 150OHM 5% 1/10W 160
R407	0RJ1001D677	MCR03EZPJ102 1KOHM 5% 1/10W 1608
R408	0RJ1001D677	MCR03EZPJ102 1KOHM 5% 1/10W 1608
R409	0RJ1000D677	MCR03EZPJ101 100OHM 5% 1/10W 160
R500	0RJ1003D677	MCR03EZPJ104 100KOHM 5% 1/10W 16
R501	0RJ1001D677	MCR03EZPJ102 1KOHM 5% 1/10W 1608
R502	0RJ0000D677	MCR03EZPJ000 0OHM 5% 1/10W 1608
R504	0RJ1500D677	MCR03EZPJ151 150OHM 5% 1/10W 160
R505	0RJ4701D677	MCR03EZPJ472 4.7KOHM 5% 1/10W 16
R508	0RJ1002D677	MCR03EZPJ103 10KOHM 5% 1/10W 160
R509	0RJ1003D677	MCR03EZPJ104 100KOHM 5% 1/10W 16
R510	0RJ0000D677	MCR03EZPJ000 0OHM 5% 1/10W 1608
R511	0RJ1000D677	MCR03EZPJ101 100OHM 5% 1/10W 160
R513	0RJ1000D677	MCR03EZPJ101 100OHM 5% 1/10W 160
R514	0RJ1003D677	MCR03EZPJ104 100KOHM 5% 1/10W 16

LOC. NO.	PART NO.	DESCRIPTION / SPECIFICATION
R515	0RJ1001D677	MCR03EZPJ102 1KOHM 5% 1/10W 1608
R516	0RJ1001D677	MCR03EZPJ102 1KOHM 5% 1/10W 1608
R518	0RJ0000D677	MCR03EZPJ000 0OHM 5% 1/10W 1608
R600	0RJ1002D677	MCR03EZPJ103 10KOHM 5% 1/10W 160
R601	0RJ1002D677	MCR03EZPJ103 10KOHM 5% 1/10W 160
R602	0RJ1002D677	MCR03EZPJ103 10KOHM 5% 1/10W 160
R603	0RJ1002D677	MCR03EZPJ103 10KOHM 5% 1/10W 160
R604	0RJ1002D677	MCR03EZPJ103 10KOHM 5% 1/10W 160
R605	0RJ1002D677	MCR03EZPJ103 10KOHM 5% 1/10W 160
R606	0RJ1001D677	MCR03EZPJ102 1KOHM 5% 1/10W 1608
R607	0RJ4700D677	MCR03EZPJ471 470OHM 5% 1/10W 160
R608	0RJ3300D677	MCR03EZPJ331 330OHM 5% 1/10W 160
R609	0RJ1001D677	MCR03EZPJ102 1KOHM 5% 1/10W 1608
R610	0RJ4701D677	MCR03EZPJ472 4.7KOHM 5% 1/10W 16
R611	0RJ4701D677	MCR03EZPJ472 4.7KOHM 5% 1/10W 16
R622	0RJ2700D677	MCR03EZPJ271 270OHM 5% 1/10W 160
R631	0RJ1000D677	MCR03EZPJ101 100OHM 5% 1/10W 160
R633	0RJ1500D677	MCR03EZPJ151 150OHM 5% 1/10W 160
R636	0RJ1000D677	MCR03EZPJ101 100OHM 5% 1/10W 160
R637	0RJ1500D677	MCR03EZPJ151 150OHM 5% 1/10W 160
R638	0RJ2700D677	MCR03EZPJ271 270OHM 5% 1/10W 160
R701	0RJ4701D677	MCR03EZPJ472 4.7KOHM 5% 1/10W 16
R702	0RJ4701D677	MCR03EZPJ472 4.7KOHM 5% 1/10W 16
R703	0RJ0332D677	MCR03EZPJ330 33OHM 5% 1/10W 1608
R704	0RJ0332D677	MCR03EZPJ330 33OHM 5% 1/10W 1608
R705	0RJ0332D677	MCR03EZPJ330 33OHM 5% 1/10W 1608
R706	0RJ0332D677	MCR03EZPJ330 33OHM 5% 1/10W 1608
R707	0RJ0000D677	MCR03EZPJ000 0OHM 5% 1/10W 1608
R708	0RJ0682D677	MCR03EZPJ680 68OHM 5% 1/10W 1608
R709	0RJ0682D677	MCR03EZPJ680 68OHM 5% 1/10W 1608
R710	0RJ0752D677	MCR03EZPJ750 75OHM 5% 1/10W 1608
R711	0RJ0102D677	MCR03EZPJ100 10OHM 5% 1/10W 1608
R712	0RJ0102D677	MCR03EZPJ100 10OHM 5% 1/10W 1608
R713	0RJ0102D677	MCR03EZPJ100 10OHM 5% 1/10W 1608
R714	0RJ0102D677	MCR03EZPJ100 10OHM 5% 1/10W 1608
R715	0RJ0102D677	MCR03EZPJ100 10OHM 5% 1/10W 1608
R716	0RJ0102D677	MCR03EZPJ100 10OHM 5% 1/10W 1608
R717	0RJ0000D677	MCR03EZPJ000 0OHM 5% 1/10W 1608
R718	0RJ0182D677	MCR03EZPJ180 18OHM 5% 1/10W 1608
R718	0RJ0102D677	MCR03EZPJ100 10OHM 5% 1/10W 1608
R719	0RJ0182D677	MCR03EZPJ180 18OHM 5% 1/10W 1608
R719	0RJ0102D677	MCR03EZPJ100 10OHM 5% 1/10W 1608
R720	0RJ1001D677	MCR03EZPJ102 1KOHM 5% 1/10W 1608
R721	0RJ0752D677	MCR03EZPJ750 75OHM 5% 1/10W 1608
R722	0RJ0000D677	MCR03EZPJ000 0OHM 5% 1/10W 1608
R723	0RJ0752D677	MCR03EZPJ750 75OHM 5% 1/10W 1608
R724	0RJ4701D677	MCR03EZPJ472 4.7KOHM 5% 1/10W 16
R725	0RJ4701D677	MCR03EZPJ472 4.7KOHM 5% 1/10W 16
R726	0RJ4701D677	MCR03EZPJ472 4.7KOHM 5% 1/10W 16
R727	0RJ4701D677	MCR03EZPJ472 4.7KOHM 5% 1/10W 16
R728	0RJ4701D677	MCR03EZPJ472 4.7KOHM 5% 1/10W 16
R729	0RJ4701D677	MCR03EZPJ472 4.7KOHM 5% 1/10W 16
R801	0RJ4703D677	MCR03EZPJ474 470KOHM 5% 1/10W 16
R802	0RJ4703D677	MCR03EZPJ474 470KOHM 5% 1/10W 16

LOC. NO.	PART NO.	DESCRIPTION / SPECIFICATION
R803	0RJ0752D477	MCR03EZPF750 75OHM 1% 1/10W 1608
R804	0RJ0752D477	MCR03EZPF750 75OHM 1% 1/10W 1608
R805	0RJ0752D477	MCR03EZPF750 75OHM 1% 1/10W 1608
R806	0RJ0682D677	MCR03EZPJ680 68OHM 5% 1/10W 1608
R807	0RJ1500D677	MCR03EZPJ151 150OHM 5% 1/10W 160
R808	0RJ1500D677	MCR03EZPJ151 150OHM 5% 1/10W 160
R809	0RJ1002D677	MCR03EZPJ103 10KOHM 5% 1/10W 160
R810	0RJ0752D677	MCR03EZPJ750 75OHM 5% 1/10W 1608
R811	0RJ1002D677	MCR03EZPJ103 10KOHM 5% 1/10W 160
R812	0RJ0222D677	MCR03EZPJ220 22OHM 5% 1/10W 1608
R813	0RJ0000D677	MCR03EZPJ000 0OHM 5% 1/10W 1608
R814	0RJ1002D677	MCR03EZPJ103 10KOHM 5% 1/10W 160
R814	0RJ9101D677	MCR03EZPJ912 9.1KOHM 5% 1/10W 16
R815	0RJ1002D677	MCR03EZPJ103 10KOHM 5% 1/10W 160
R815	0RJ9101D677	MCR03EZPJ912 9.1KOHM 5% 1/10W 16
R816	0RJ1001D677	MCR03EZPJ102 1KOHM 5% 1/10W 1608
R817	0RJ1001D677	MCR03EZPJ102 1KOHM 5% 1/10W 1608
R818	0RJ5602D477	MCR03EZPF563 56KOHM 1% 1/10W 160
R819	0RJ0222D677	MCR03EZPJ220 22OHM 5% 1/10W 1608
R820	0RJ0222D677	MCR03EZPJ220 22OHM 5% 1/10W 1608
R821	0RJ0222D677	MCR03EZPJ220 22OHM 5% 1/10W 1608
R822	0RJ0222D677	MCR03EZPJ220 22OHM 5% 1/10W 1608
R823	0RJ1102D677	MCR03EZPJ113 11KOHM 5% 1/10W 160
R825	0RJ5600D677	MCR03EZPJ561 560OHM 5% 1/10W 160
R827	0RJ5600D677	MCR03EZPJ561 560OHM 5% 1/10W 160
R831	0RJ0000D677	MCR03EZPJ000 0OHM 5% 1/10W 1608
R833	0RJ4701D677	MCR03EZPJ472 4.7KOHM 5% 1/10W 16
R834	0RJ1002D677	MCR03EZPJ103 10KOHM 5% 1/10W 160
R836	0RJ0000D677	MCR03EZPJ000 0OHM 5% 1/10W 1608
R900	0RJ0752D477	MCR03EZPF750 75OHM 1% 1/10W 1608
R901	0RJ0222D677	MCR03EZPJ220 22OHM 5% 1/10W 1608
R902	0RJ0752D477	MCR03EZPF750 75OHM 1% 1/10W 1608
R903	0RJ0222D677	MCR03EZPJ220 22OHM 5% 1/10W 1608
R904	0RJ0752D477	MCR03EZPF750 75OHM 1% 1/10W 1608
R905	0RJ0222D677	MCR03EZPJ220 22OHM 5% 1/10W 1608
R906	0RJ4703D677	MCR03EZPJ474 470KOHM 5% 1/10W 16
R907	0RJ1002D677	MCR03EZPJ103 10KOHM 5% 1/10W 160
R908	0RJ4703D677	MCR03EZPJ474 470KOHM 5% 1/10W 16
R909	0RJ1102D677	MCR03EZPJ113 11KOHM 5% 1/10W 160
R910	0RJ1002D677	MCR03EZPJ103 10KOHM 5% 1/10W 160
R911	0RJ1102D677	MCR03EZPJ113 11KOHM 5% 1/10W 160
SWITCHs		
SW2001	140-058E	THVV502GBC 1C1P 12VDC 0.05A HORI
SW4000	140-058B	EVQPB205K 1C1P 15VDC 0.02A VERTI
SW4001	140-058B	EVQPB205K 1C1P 15VDC 0.02A VERTI
SW4002	140-058B	EVQPB205K 1C1P 15VDC 0.02A VERTI
SW4003	140-058B	EVQPB205K 1C1P 15VDC 0.02A VERTI
SW4004	140-058B	EVQPB205K 1C1P 15VDC 0.02A VERTI
SW4005	140-058B	EVQPB205K 1C1P 15VDC 0.02A VERTI
SW4006	140-058B	EVQPB205K 1C1P 15VDC 0.02A VERTI

LOC. NO.	PART NO.	DESCRIPTION / SPECIFICATION
TRANSISTORS		
Q1102	0TR387500AA	2SC3875S(ALY) NPN 5V 60V 50V 150
Q300	0TR387500AA	2SC3875S(ALY) NPN 5V 60V 50V 150
Q302	0TR150400BA	2SA1504S(ASY) PNP -5V -50V -50V
Q303	0TR150400BA	2SA1504S(ASY) PNP -5V -50V -50V
Q304	0TR387500AA	2SC3875S(ALY) NPN 5V 60V 50V 150
Q304	0TR387500AA	2SC3875S(ALY) NPN 5V 60V 50V 150
Q305	0TR387500AA	2SC3875S(ALY) NPN 5V 60V 50V 150
Q500	0TR150400BA	2SA1504S(ASY) PNP -5V -50V -50V
Q501	0TR387500AA	2SC3875S(ALY) NPN 5V 60V 50V 150
Q600	0TR387500AA	2SC3875S(ALY) NPN 5V 60V 50V 150
Q601	0TR387500AA	2SC3875S(ALY) NPN 5V 60V 50V 150
Q602	0TR387500AA	2SC3875S(ALY) NPN 5V 60V 50V 150
Q603	0TR150400BA	2SA1504S(ASY) PNP -5V -50V -50V
Q606	0TR150400BA	2SA1504S(ASY) PNP -5V -50V -50V
Q607	0TR150400BA	2SA1504S(ASY) PNP -5V -50V -50V
MISCELLANEOUSs		
B1	3890TKD002Z	Box,BOX SW 586 356 486 1 COLOR C/SKD
B3	3890TKD002P	Box,LB500J(PCB) BRAND 542*397*445
B3	3890TKD002P	Box,LB500J(PCB) BRAND 542*397*445
B4	3890V00067F	Box,"BOX SW 0 0 0 1 COLOR PC-63A 29""
B5	MAY36843301	Box,BOX DW 526 108 405 2 COLOR M228W
IC2001	6712SCA232A	Receiver Module,TSOP34838SO1 2.7TO5.5V
LED2001	0DLGP0080AA	"LED,DIP",GP34052ME/P507-ZSY-50-HB
P1	3918TKK038A	Packing,"(1090*900) LCD, LB800H"
P2	MFZ36188701	Packing,MOLD EPS M228W EPS MNT 22'
P3	3918TKK038J	Packing,538*390 LB500J PCB
P4	3918TKK038R	Packing,COMPLEX 1070*955 SW -
P5	MFZ37372403	Packing,BOX DW 584 50 486 NO PRINTING
P6	3918TKK038J	Packing,538*390 LB500J PCB
P6	3918TKK038J	Packing,538*390 LB500J PCB
P7	3918TKK040A	Packing,542*70 MAIN PCB(B)
P7	3918TKK040A	Packing,542*70 MAIN PCB(B)
P8	3918TKK040B	Packing,397*70 LB500J MAIN PCB(S)
P8	3918TKK040B	Packing,397*70 LB500J MAIN PCB(S)
P9	400-C17F	Packing,(1000X1050)CS771 DIGITAL
P9	400-C17F	Packing,(1000X1050)CS771 DIGITAL
S1	6620K00017B	"Socket,Power",DAC-11S L2 3P STRAIGHT
X100	6202VDT002B	Crystal,SX-1 14.31818MHZ 30PPM(16PF) 14.
ACCESSORIEs		
A1	MFL37805901	Manual,PRINTING USER - BRAND M198WA
A2	MKJ32816602	Remote Controller,"MOLD ABS 380 CL81
A3	6410TEW010A	Power Cord,"CEE,LP-34A&H05VV-FX3C,LS-
A3	6410TBW004A	Power Cord,LP-61L+GFC18N+<B90A+LS-
A4	130-013B	"Battery,Manganese",R03(STC) 1.5V
A5	68509F0003A	"Cable,Assembly",D-SUB TO D-SUB UL20276
A6	68509J0004A	"Cable,Assembly",DVI-D TO DVI-D UL20276
A7	6852TAZ006P	"Cable,Assembly",KCA-ST-3-0010 STEREO
A8	SAB30693401	S/W Package,M198WA/M208WA/M228WA

LOC. NO.	PART NO.	DESCRIPTION / SPECIFICATION

SCHEMATIC DIAGRAM

1. MSTAR

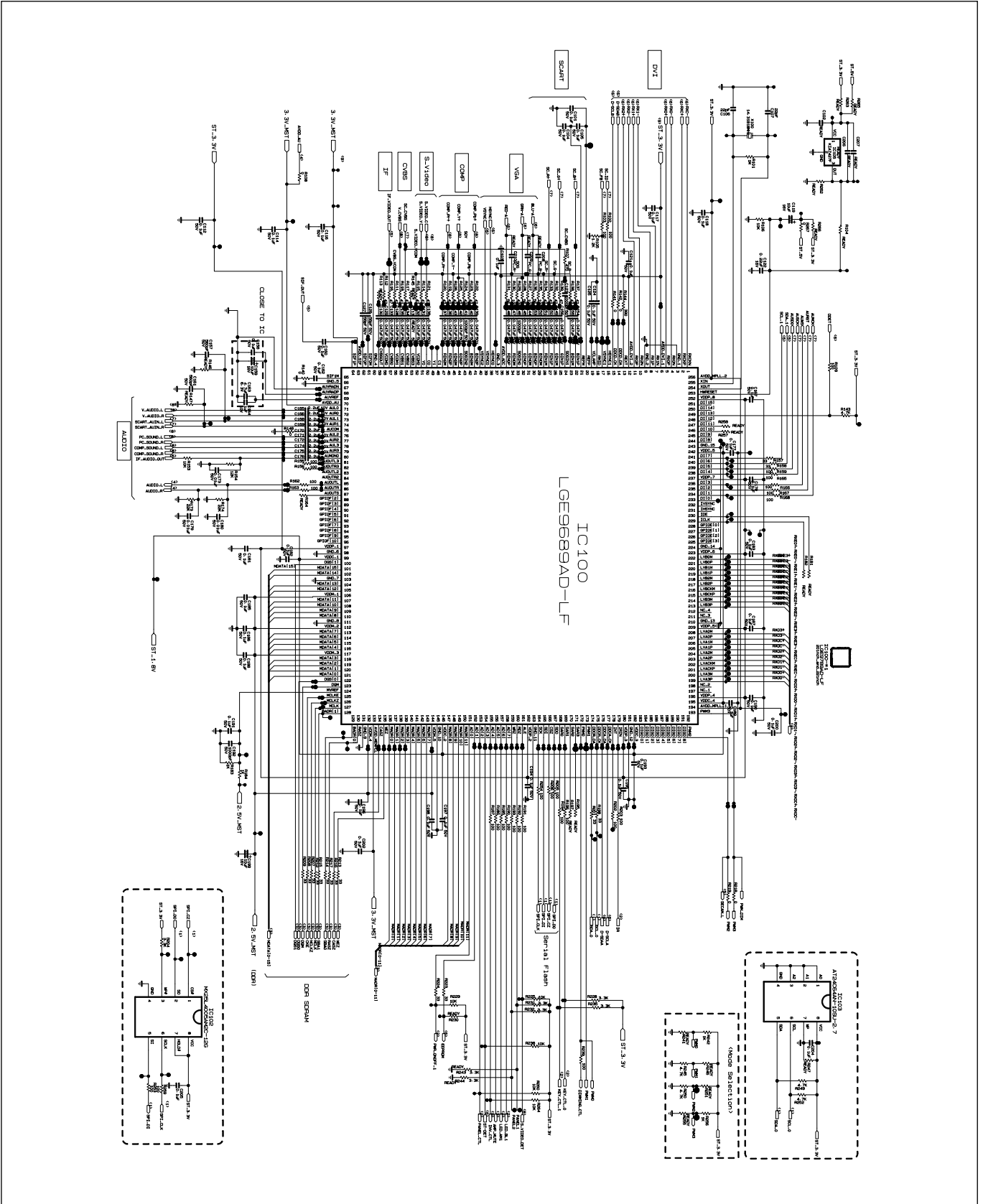

2. PANEL & CONNECTOR

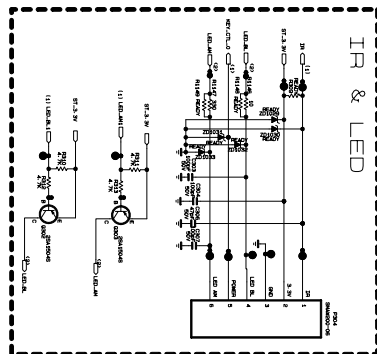
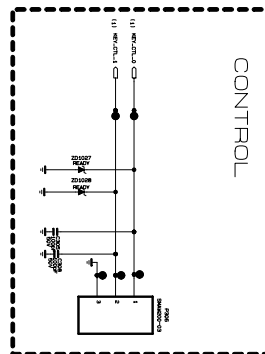
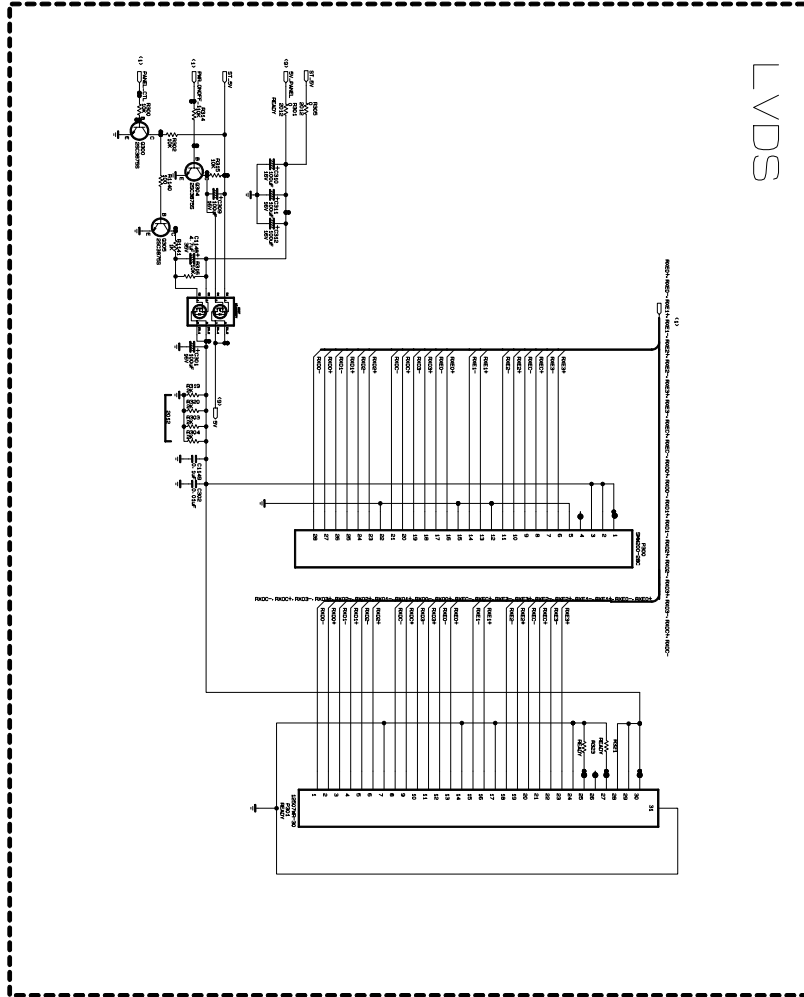

3. DDR

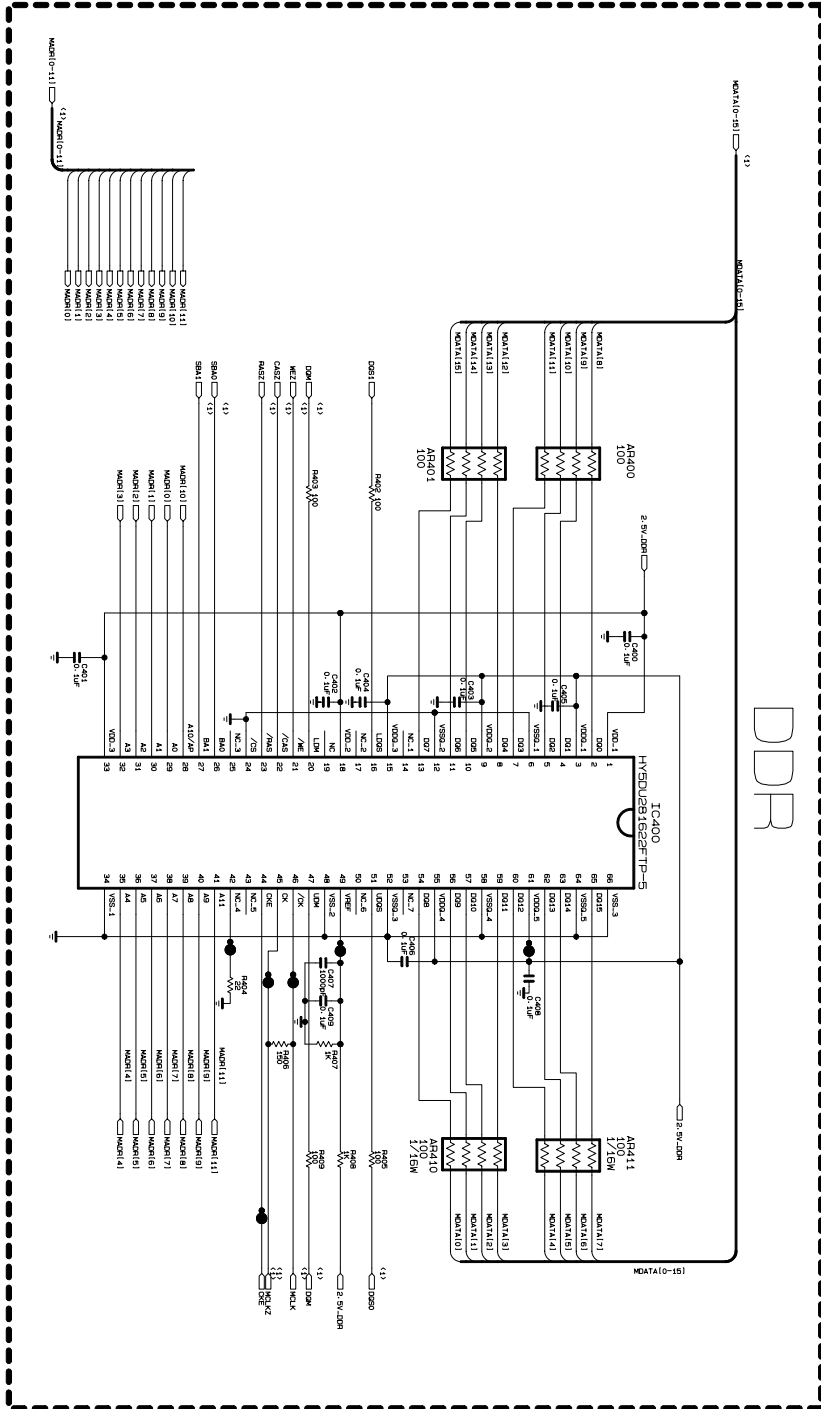

DDR

4. AMP

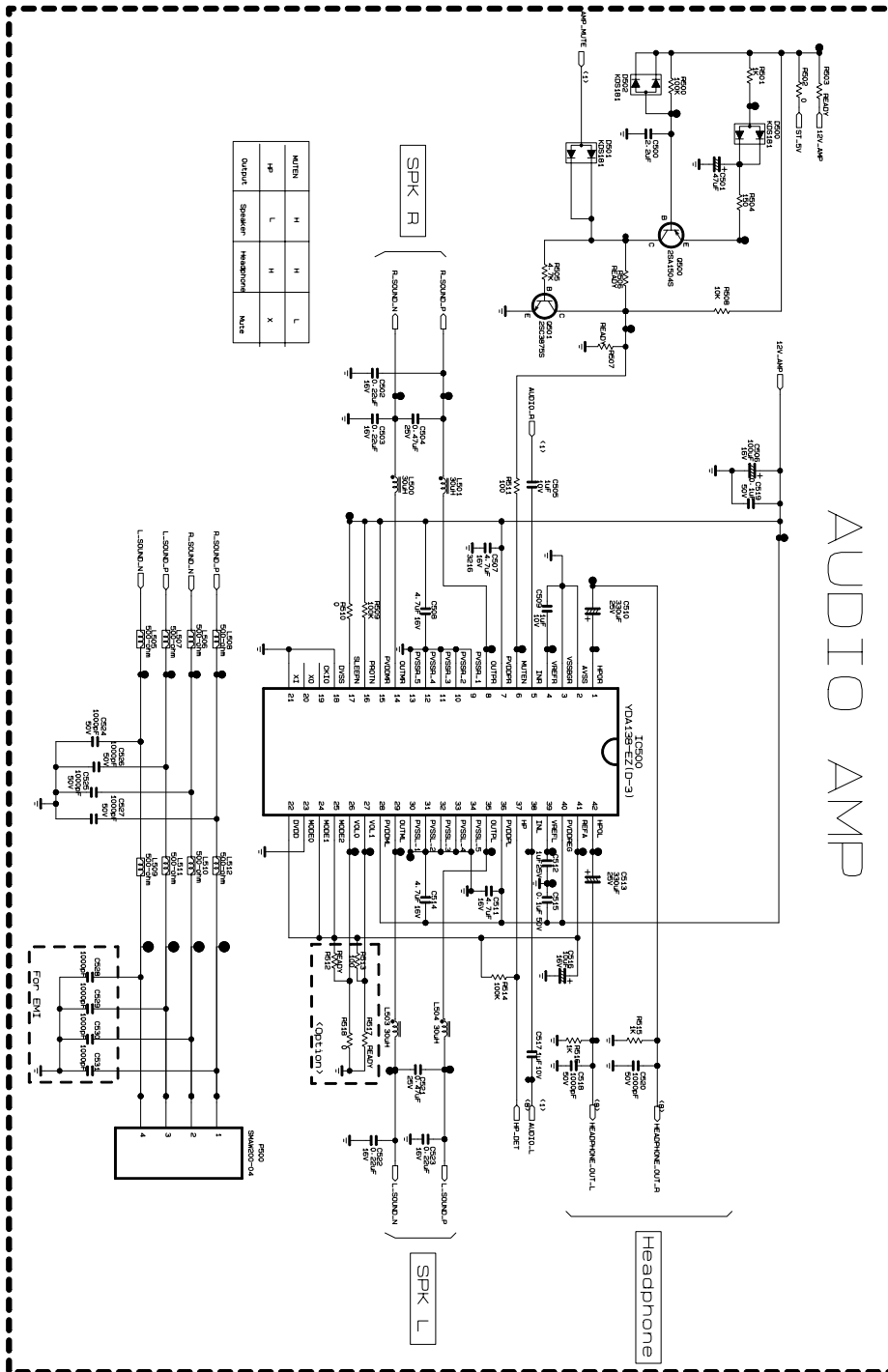

5. TUNER

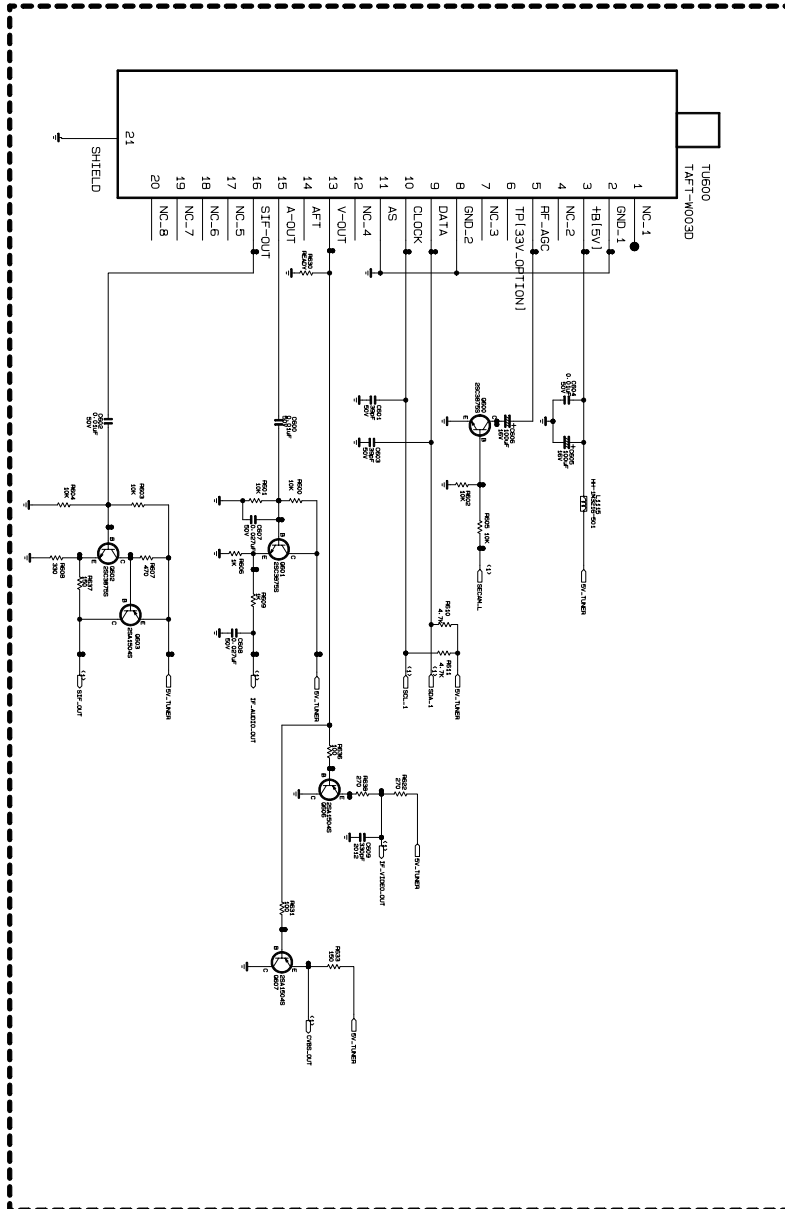

TUNER

6. DSUB & DVI

D-SUB & DVI

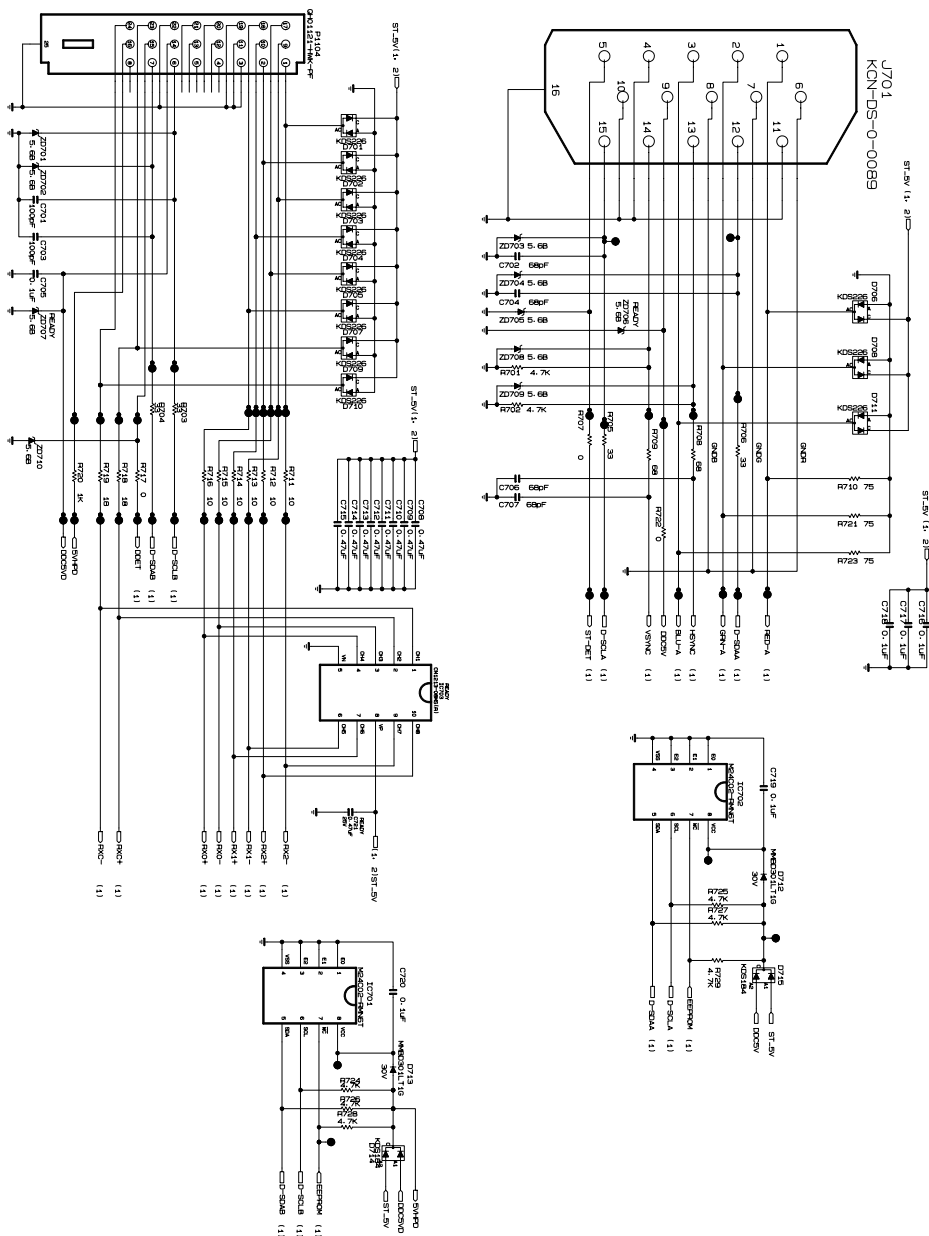

7. SCART & DAC

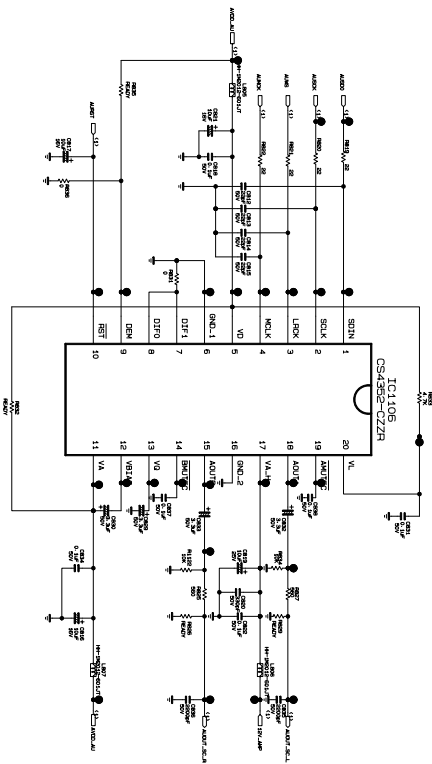
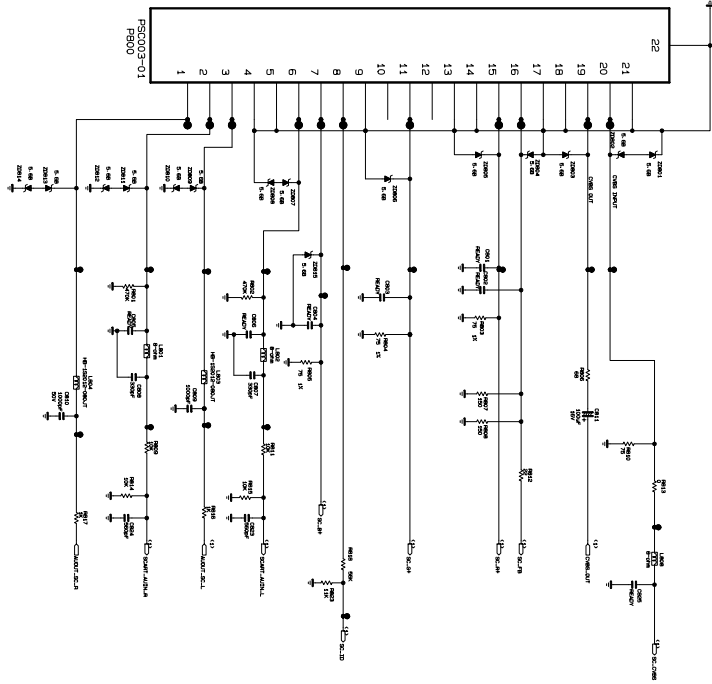

SCART & DAC

8. JACK

S_Video

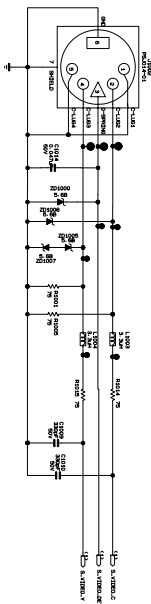

CVBS

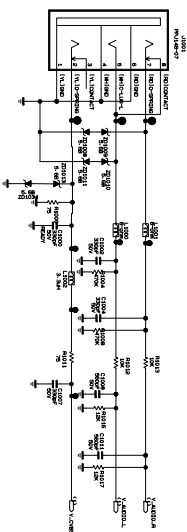

PC SOUND INPUT

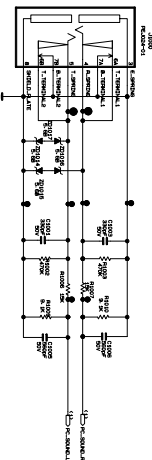

Headphone

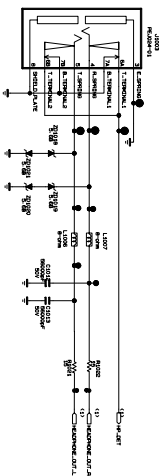

COMPONENT

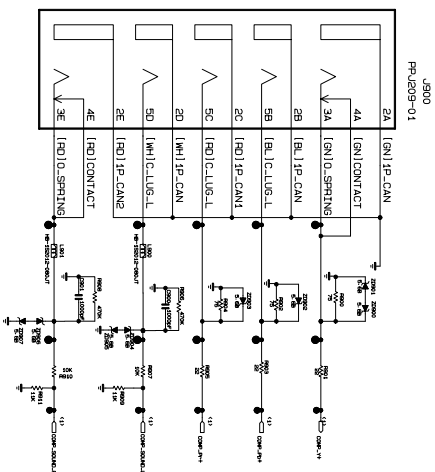

9. POWER

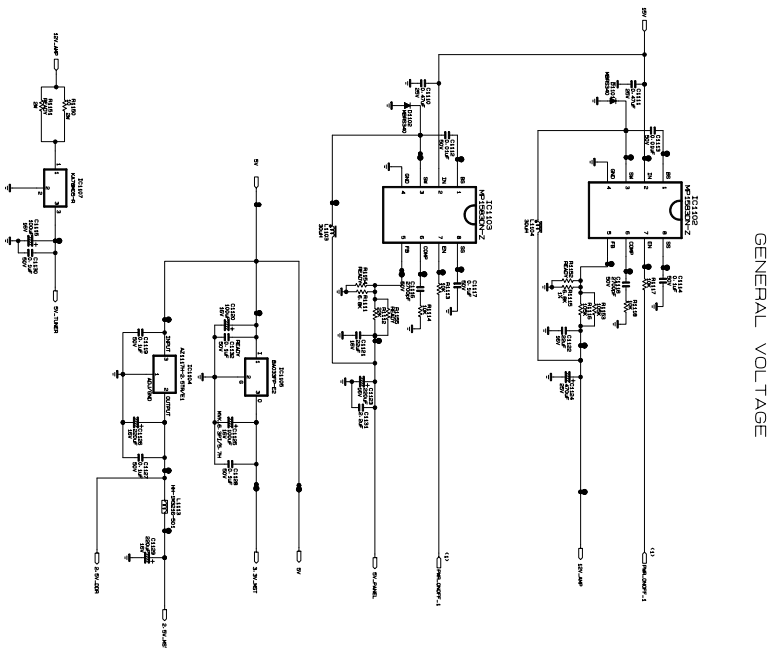
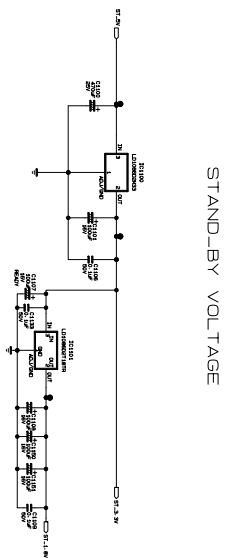
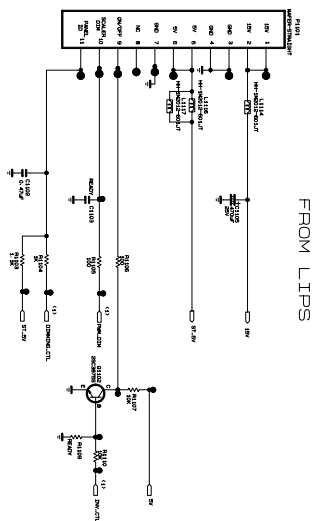

PRINTED CIRCUIT BOARD

MAIN (TOP)

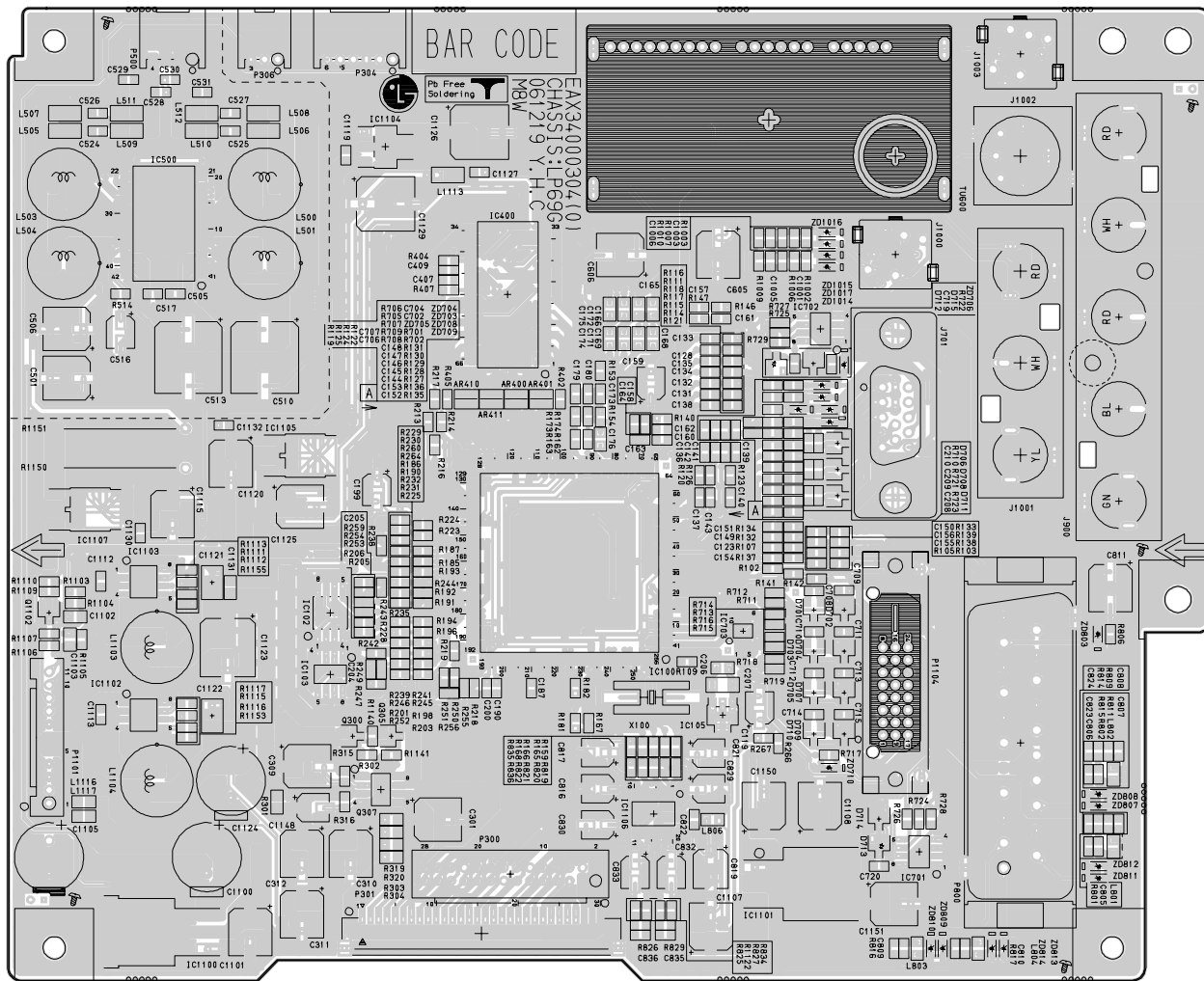

CONTROL (BOTTOM)

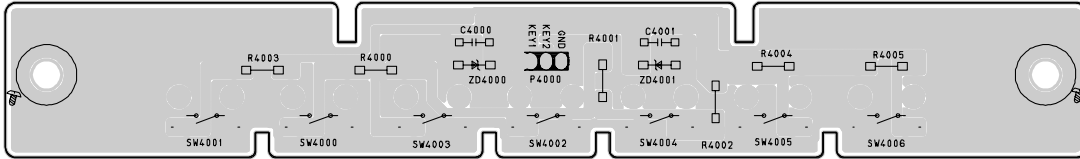



P/NO : MFL36713674

Jan. 2007
Printed in Korea