



COLOR MONITOR

SERVICE MANUAL

MODEL: FLATRON L1918S (L1918S-BNQ/SNQ.A**MQP for LPL TLB2, A**SQP for HSD A01, A**RQP for HSD D10, A**OQP for LPL TLL1 & TLL3) **Sales Market

CAUTION

BEFORE SERVICING THE UNIT,
READ THE **SAFETY PRECAUTIONS** IN THIS MANUAL.



*To apply the **MSTAR Chip**.

CONTENTS

SPECIFICATIONS	2	SERVICE OSD	16
PRECAUTIONS	3	TROUBLESHOOTING GUIDE	17
TIMING CHART	7	WIRING DIAGRAM	23
DISASSEMBLY	8	EXPLODED VIEW	24
BLOCK DIAGRAM	11	REPLACEMENT PARTS LIST	26
DISCRIPTION OF BLOCK DIAGRAM	13	SCHEMATIC DIAGRAM	37
ADJUSTMENT	15		

SPECIFICATIONS

1. LCD CHARACTERISTICS

Type : TFT Color LCD Module
 Active Display Area : 19 inch
 Pixel Pitch : 0.294 (H) x 0.294 (V)
 Color Depth : 8bits, 16.7M colors
 Size : 396 (H) x 324 (V) x 16.5(D)
 Electrical Interface : LVDS
 Surface Treatment : Hard-coating(3H), Anti-Glare
 Operating Mode : Normally White, Transmissive mode
 Backlight Unit : 4-CCFL

2. OPTICAL CHARACTERISTICS

2-1. Viewing Angle by Contrast Ratio > 10

Left : -70° min., -80°(Typ) Right : +70° min., +80°(Typ)
 Top : +60° min., +75°(Typ) Bottom : -70° min., -85°(Typ)

2-2. Luminance : 250(min), 300(Typ) (Full White pattern, 0.7V) -6500K
 : 150(min) (Full White pattern, 0.7V) -9300K

2-3. Contrast Ratio : 500(min), 700(Tye)

3. SIGNAL (Refer to the Timing Chart)

3-1. Sync Signal
 • Type : Separate Sync, SOG

3-2. Video Input Signal

1) Type : R, G, B Analog
 2) Voltage Level : 0~0.71 V
 a) Color 0, 0 : 0 Vp-p
 b) Color 7, 0 : 0.467Vp-p
 c) Color 15, 0 : 0.714Vp-p
 3) Input Impedance : 75Ω

3-3. Operating Frequency

Horizontal : 30 ~ 83kHz
 Vertical : 56 ~ 75Hz

4. Max. Resolution

D-sub Analog : 1280 x 1024@75Hz

5. POWER SUPPLY

5-1. Power : AC 100~240V, 50/60Hz , 0.8A

5-2. Power Consumption

MODE	H/V SYNC	VIDEO	POWER CONSUMPTION	LED COLOR
POWER ON (NORMAL)	ON/ON	ACTIVE	34 W(Typical)	GREEN
STAND-BY	OFF/ON	OFF	less than 1 W	AMBER
SUSPEND	ON/OFF	OFF	less than 1 W	AMBER
DPMS OFF	OFF/OFF	OFF	less than 1 W	AMBER
POWER S/W OFF	-	-	less than 1 W	OFF

6. ENVIRONMENT

6-1. Operating Temperature : 10°C~35°C (50°F~95°F)
 (Ambient)

6-2. Relative Humidity : 20%~80% (Non-condensing)

6-3. MTBF : 50,000 HRS with 90% Confidence
 Lamp Life : 50,000 Hours(Min)

7. DIMENSIONS (with TILT/SWIVEL)

Width : 418 mm (16.45 inches)
 Depth : 180.1mm (7.09 inches)
 Height : 414 mm (14.98 inches)

8. WEIGHT (with TILT/SWIVEL)

Net. Weight : 4.3 kg
 (9.48 lbs)

PRECAUTION

WARNING FOR THE SAFETY-RELATED COMPONENT.

- There are some special components used in LCD monitor that are important for safety. **These parts are marked \triangle on the schematic diagram and the replacement parts list.** It is essential that these critical parts should be replaced with the manufacturer's specified parts to prevent electric shock, fire or other hazard.
- Do not modify original design without obtaining written permission from manufacturer or you will void the original parts and labor guarantee.

TAKE CARE DURING HANDLING THE LCD MODULE WITH BACKLIGHT UNIT.

- Must mount the module using mounting holes arranged in four corners.
- Do not press on the panel, edge of the frame strongly or electric shock as this will result in damage to the screen.
- Do not scratch or press on the panel with any sharp objects, such as pencil or pen as this may result in damage to the panel.
- Protect the module from the ESD as it may damage the electronic circuit (C-MOS).
- Make certain that treatment person's body are grounded through wrist band.
- Do not leave the module in high temperature and in areas of high humidity for a long time.
- The module not be exposed to the direct sunlight.
- Avoid contact with water as it may a short circuit within the module.
- If the surface of panel become dirty, please wipe it off with a softmaterial. (Cleaning with a dirty or rough cloth may damage the panel.)

\triangle CAUTION

Please use only a plastic screwdriver to protect yourself from shock hazard during service operation.

\triangle WARNING

BE CAREFUL ELECTRIC SHOCK !

- If you want to replace with the new backlight (CCFL) or inverter circuit, must disconnect the AC adapter because high voltage appears at inverter circuit about 650Vrms.
- Handle with care wires or connectors of the inverter circuit. If the wires are pressed cause short and may burn or take fire.

Leakage Current Hot Check Circuit

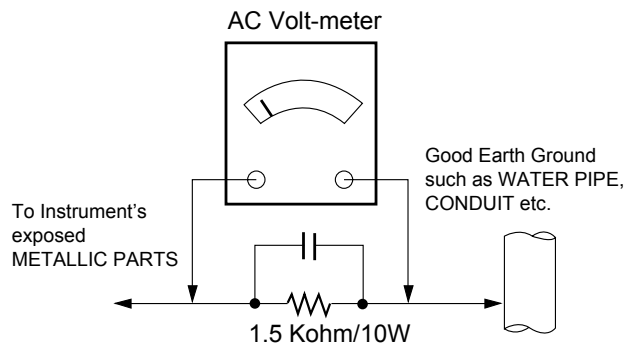

SERVICING PRECAUTIONS

CAUTION: Before servicing receivers covered by this service manual and its supplements and addenda, read and follow the **SAFETY PRECAUTIONS** on page 3 of this publication.

NOTE: If unforeseen circumstances create conflict between the following servicing precautions and any of the safety precautions on page 3 of this publication, always follow the safety precautions. Remember: Safety First.

General Servicing Precautions

1. Always unplug the receiver AC power cord from the AC power source before;
 - a. Removing or reinstalling any component, circuit board module or any other receiver assembly.
 - b. Disconnecting or reconnecting any receiver electrical plug or other electrical connection.
 - c. Connecting a test substitute in parallel with an electrolytic capacitor in the receiver.

CAUTION: A wrong part substitution or incorrect polarity installation of electrolytic capacitors may result in an explosion hazard.
 - d. Discharging the picture tube anode.
2. Test high voltage only by measuring it with an appropriate high voltage meter or other voltage measuring device (DVM, FETVOM, etc) equipped with a suitable high voltage probe.
Do not test high voltage by "drawing an arc".
3. Discharge the picture tube anode only by (a) first connecting one end of an insulated clip lead to the degaussing or kine aquadag grounding system shield at the point where the picture tube socket ground lead is connected, and then (b) touch the other end of the insulated clip lead to the picture tube anode button, using an insulating handle to avoid personal contact with high voltage.
4. Do not spray chemicals on or near this receiver or any of its assemblies.
5. Unless specified otherwise in this service manual, clean electrical contacts only by applying the following mixture to the contacts with a pipe cleaner, cotton-tipped stick or comparable non-abrasive applicator; 10% (by volume) Acetone and 90% (by volume) isopropyl alcohol (90%-99% strength)
CAUTION: This is a flammable mixture.
Unless specified otherwise in this service manual, lubrication of contacts is not required.
6. Do not defeat any plug/socket B+ voltage interlocks with which receivers covered by this service manual might be equipped.
7. Do not apply AC power to this instrument and/or any of its electrical assemblies unless all solid-state device heat sinks are correctly installed.
8. Always connect the test receiver ground lead to the receiver chassis ground before connecting the test receiver positive lead.
Always remove the test receiver ground lead last.

9. Use with this receiver only the test fixtures specified in this service manual.

CAUTION: Do not connect the test fixture ground strap to any heat sink in this receiver.

Electrostatically Sensitive (ES) Devices

Some semiconductor (solid-state) devices can be damaged easily by static electricity. Such components commonly are called *Electrostatically Sensitive (ES) Devices*. Examples of typical ES devices are integrated circuits and some field-effect transistors and semiconductor "chip" components. The following techniques should be used to help reduce the incidence of component damage caused by static by static electricity.

1. Immediately before handling any semiconductor component or semiconductor-equipped assembly, drain off any electrostatic charge on your body by touching a known earth ground. Alternatively, obtain and wear a commercially available discharging wrist strap device, which should be removed to prevent potential shock reasons prior to applying power to the unit under test.
2. After removing an electrical assembly equipped with ES devices, place the assembly on a conductive surface such as aluminum foil, to prevent electrostatic charge buildup or exposure of the assembly.
3. Use only a grounded-tip soldering iron to solder or unsolder ES devices.
4. Use only an anti-static type solder removal device. Some solder removal devices not classified as "anti-static" can generate electrical charges sufficient to damage ES devices.
5. Do not use freon-propelled chemicals. These can generate electrical charges sufficient to damage ES devices.
6. Do not remove a replacement ES device from its protective package until immediately before you are ready to install it. (Most replacement ES devices are packaged with leads electrically shorted together by conductive foam, aluminum foil or comparable conductive material).
7. Immediately before removing the protective material from the leads of a replacement ES device, touch the protective material to the chassis or circuit assembly into which the device will be installed.
CAUTION: Be sure no power is applied to the chassis or circuit, and observe all other safety precautions.
8. Minimize bodily motions when handling unpackaged replacement ES devices. (Otherwise harmless motion such as the brushing together of your clothes fabric or the lifting of your foot from a carpeted floor can generate static electricity sufficient to damage an ES device.)

General Soldering Guidelines

1. Use a grounded-tip, low-wattage soldering iron and appropriate tip size and shape that will maintain tip temperature within the range of 500° F to 600° F.
2. Use an appropriate gauge of RMA resin-core solder composed of 60 parts tin/40 parts lead.
3. Keep the soldering iron tip clean and well tinned.
4. Thoroughly clean the surfaces to be soldered. Use a small wire-bristle (0.5 inch, or 1.25cm) brush with a metal handle.

Do not use freon-propelled spray-on cleaners.

5. Use the following unsoldering technique
 - a. Allow the soldering iron tip to reach normal temperature.
(500° F to 600° F)
 - b. Heat the component lead until the solder melts.
 - c. Quickly draw the melted solder with an anti-static, suction-type solder removal device or with solder braid.

CAUTION: Work quickly to avoid overheating the circuitboard printed foil.

6. Use the following soldering technique.
 - a. Allow the soldering iron tip to reach a normal temperature (500° F to 600° F)
 - b. First, hold the soldering iron tip and solder the strand against the component lead until the solder melts.
 - c. Quickly move the soldering iron tip to the junction of the component lead and the printed circuit foil, and hold it there only until the solder flows onto and around both the component lead and the foil.

CAUTION: Work quickly to avoid overheating the circuit board printed foil.

- d. Closely inspect the solder area and remove any excess or splashed solder with a small wire-bristle brush.

IC Remove/Replacement

Some chassis circuit boards have slotted holes (oblong) through which the IC leads are inserted and then bent flat against the circuit foil. When holes are the slotted type, the following technique should be used to remove and replace the IC. When working with boards using the familiar round hole, use the standard technique as outlined in paragraphs 5 and 6 above.

Removal

1. Desolder and straighten each IC lead in one operation by gently prying up on the lead with the soldering iron tip as the solder melts.
2. Draw away the melted solder with an anti-static suction-type solder removal device (or with solder braid) before removing the IC.

Replacement

1. Carefully insert the replacement IC in the circuit board.
2. Carefully bend each IC lead against the circuit foil pad and solder it.
3. Clean the soldered areas with a small wire-bristle brush. (It is not necessary to reapply acrylic coating to the areas).

"Small-Signal" Discrete Transistor

Removal/Replacement

1. Remove the defective transistor by clipping its leads as close as possible to the component body.
2. Bend into a "U" shape the end of each of three leads remaining on the circuit board.
3. Bend into a "U" shape the replacement transistor leads.
4. Connect the replacement transistor leads to the corresponding leads extending from the circuit board and crimp the "U" with long nose pliers to insure metal to metal contact then solder each connection.

Power Output, Transistor Device

Removal/Replacement

1. Heat and remove all solder from around the transistor leads.
2. Remove the heat sink mounting screw (if so equipped).
3. Carefully remove the transistor from the heat sink of the circuit board.
4. Insert new transistor in the circuit board.
5. Solder each transistor lead, and clip off excess lead.
6. Replace heat sink.

Diode Removal/Replacement

1. Remove defective diode by clipping its leads as close as possible to diode body.
2. Bend the two remaining leads perpendicular y to the circuit board.
3. Observing diode polarity, wrap each lead of the new diode around the corresponding lead on the circuit board.
4. Securely crimp each connection and solder it.
5. Inspect (on the circuit board copper side) the solder joints of the two "original" leads. If they are not shiny, reheat them and if necessary, apply additional solder.

Fuse and Conventional Resistor

Removal/Replacement

1. Clip each fuse or resistor lead at top of the circuit board hollow stake.
2. Securely crimp the leads of replacement component around notch at stake top.
3. Solder the connections.

CAUTION: Maintain original spacing between the replaced component and adjacent components and the circuit board to prevent excessive component temperatures.

Circuit Board Foil Repair

Excessive heat applied to the copper foil of any printed circuit board will weaken the adhesive that bonds the foil to the circuit board causing the foil to separate from or "lift-off" the board. The following guidelines and procedures should be followed whenever this condition is encountered.

At IC Connections

To repair a defective copper pattern at IC connections use the following procedure to install a jumper wire on the copper pattern side of the circuit board. (Use this technique only on IC connections).

1. Carefully remove the damaged copper pattern with a sharp knife. (Remove only as much copper as absolutely necessary).
2. Carefully scratch away the solder resist and acrylic coating (if used) from the end of the remaining copper pattern.
3. Bend a small "U" in one end of a small gauge jumper wire and carefully crimp it around the IC pin. Solder the IC connection.
4. Route the jumper wire along the path of the out-away copper pattern and let it overlap the previously scraped end of the good copper pattern. Solder the overlapped area and clip off any excess jumper wire.

At Other Connections

Use the following technique to repair the defective copper pattern at connections other than IC Pins. This technique involves the installation of a jumper wire on the component side of the circuit board.

1. Remove the defective copper pattern with a sharp knife.
Remove at least 1/4 inch of copper, to ensure that a hazardous condition will not exist if the jumper wire opens.
2. Trace along the copper pattern from both sides of the pattern break and locate the nearest component that is directly connected to the affected copper pattern.
3. Connect insulated 20-gauge jumper wire from the lead of the nearest component on one side of the pattern break to the lead of the nearest component on the other side.

Carefully crimp and solder the connections.

CAUTION: Be sure the insulated jumper wire is dressed so the it does not touch components or sharp edges.

TIMING CHART

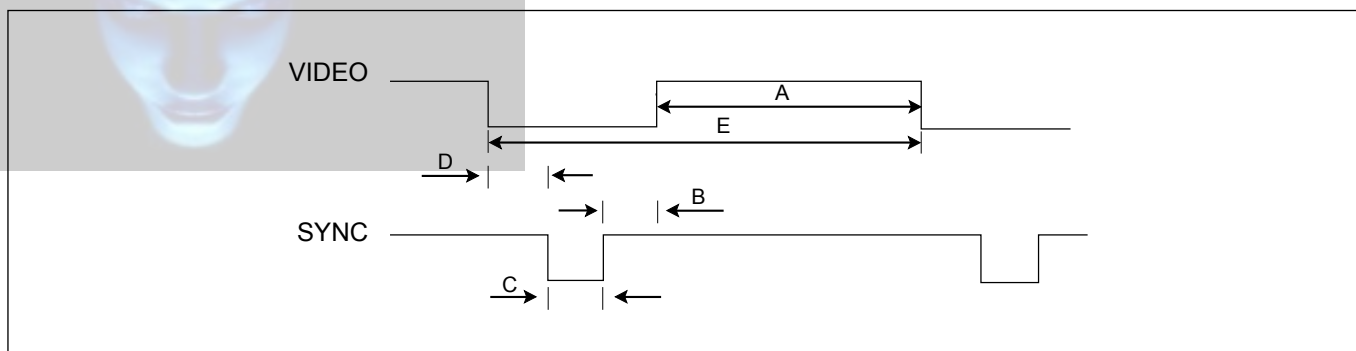

MODE	H / V	Sync Polarity	Dot Clock	Frequency	Total Period (E)	Video Active Time (A)	Sync Duration (D)	Front Porch (C)	Blanking Time (B)	Resolution
1	H(Pixels)	+	25.175	31.469	800	640	16	96	48	640 x 350
	V(Lines)	-		70.09	449	350	37	2	60	
2	H(Pixels)	-	28.321	31.468	900	720	18	108	54	720 X 400
	V(Lines)	+		70.08	449	400	12	2	35	
3	H(Pixels)	-	25.175	31.469	800	640	16	96	48	640 x 480
	V(Lines)	-		59.94	525	480	10	2	33	
4	H(Pixels)	-	31.5	37.5	840	640	16	64	120	640 x 480
	V(Lines)	-		75	500	480	1	3	16	
5	H(Pixels)	+	40.0	37.879	1056	800	40	128	88	800 x 600
	V(Lines)	+		60.317	628	600	1	4	23	
6	H(Pixels)	+	49.5	46.875	1056	800	16	80	160	800 x 600
	V(Lines)	+		75.0	625	600	1	3	21	
7	H(Pixels)	+/-	57.283	49.725	1152	832	32	64	224	832 x 624
	V(Lines)	+/-		74.55	667	624	1	3	39	
8	H(Pixels)	-	65.0	48.363	1344	1024	24	136	160	1024 x 768
	V(Lines)	-		60.0	806	768	3	6	29	
9	H(Pixels)	-	78.5	60.023	1312	1024	16	96	176	1024 x 768
	V(Lines)	-		75.029	800	768	1	3	28	
10	H(Pixels)	+/-	100.0	68.681	1456	1152	32	128	144	1152 x 870
	V(Lines)	+/-		75.062	915	870	3	3	39	
11	H(Pixels)	+/-	92.978	61.805	1504	1152	18	134	200	1152 x 900
	V(Lines)	+/-		65.96	937	900	2	4	31	
12	H(Pixels)	+	108.0	63.981	1688	1280	48	112	248	1280 x 1024
	V(Lines)	+		60.02	1066	1024	1	3	38	
13	H(Pixels)	+	135.0	79.976	1688	1280	16	144	248	1280 x 1024
	V(Lines)	+		75.035	1066	1024	1	3	38	

DISASSEMBLY-Set

#1

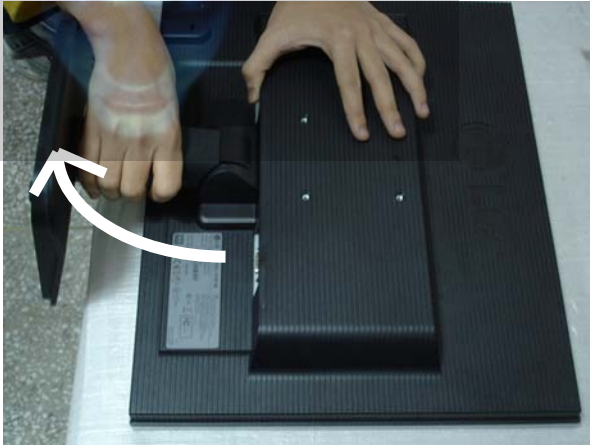

Hold the head & stand base and then twist Stand until "Click". After then pull down the stand.

#2

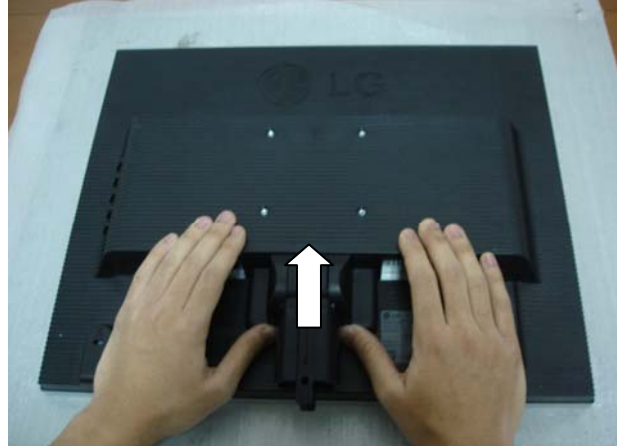

Push the hinge cover as arrow direction.

#3

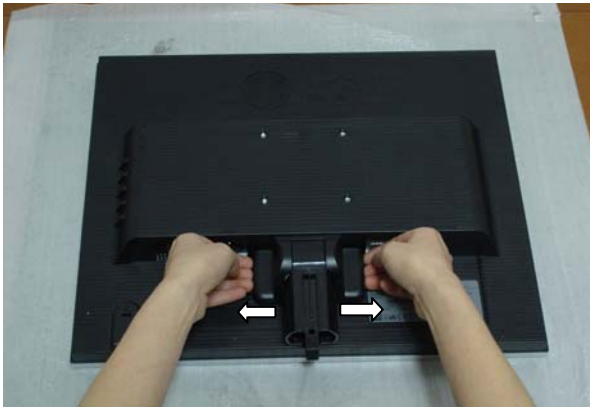

Disassemble the hinge cover as arrow direction.

#4



Remove the four screws.

#5



Disassemble the bezel from the bottom with a thin card. There are two clips on the button.

#6



Disassembly Back Cover.

#7

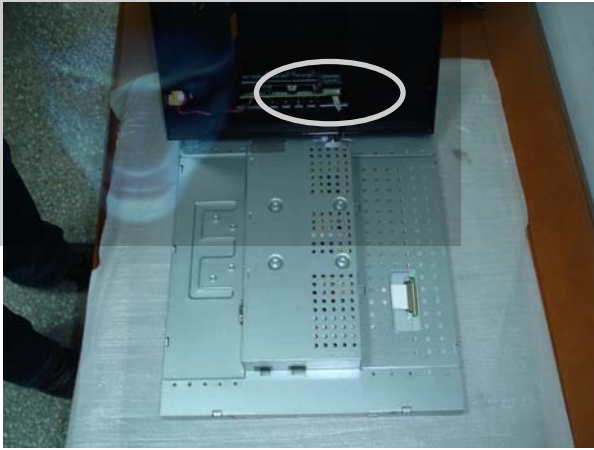

Disassemble connector

DISASSEMBLY-Stand

#1



Pull the Base 2 ea Latches to inside until losing elasticity.

#2



Consequently, pull the stand body directly.

#3



Separate Stand Body & Stand Base.

#4



Fix Stand Base & Stand Body.

#5

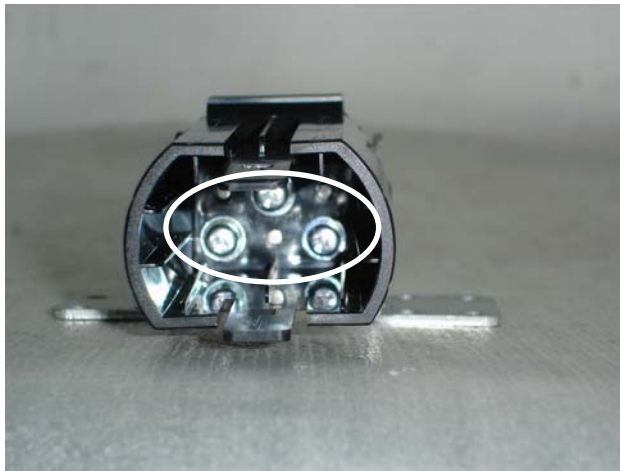

Remove the three screws.

#6



Separate the hinge and stand.

BLOCK DIAGRAM

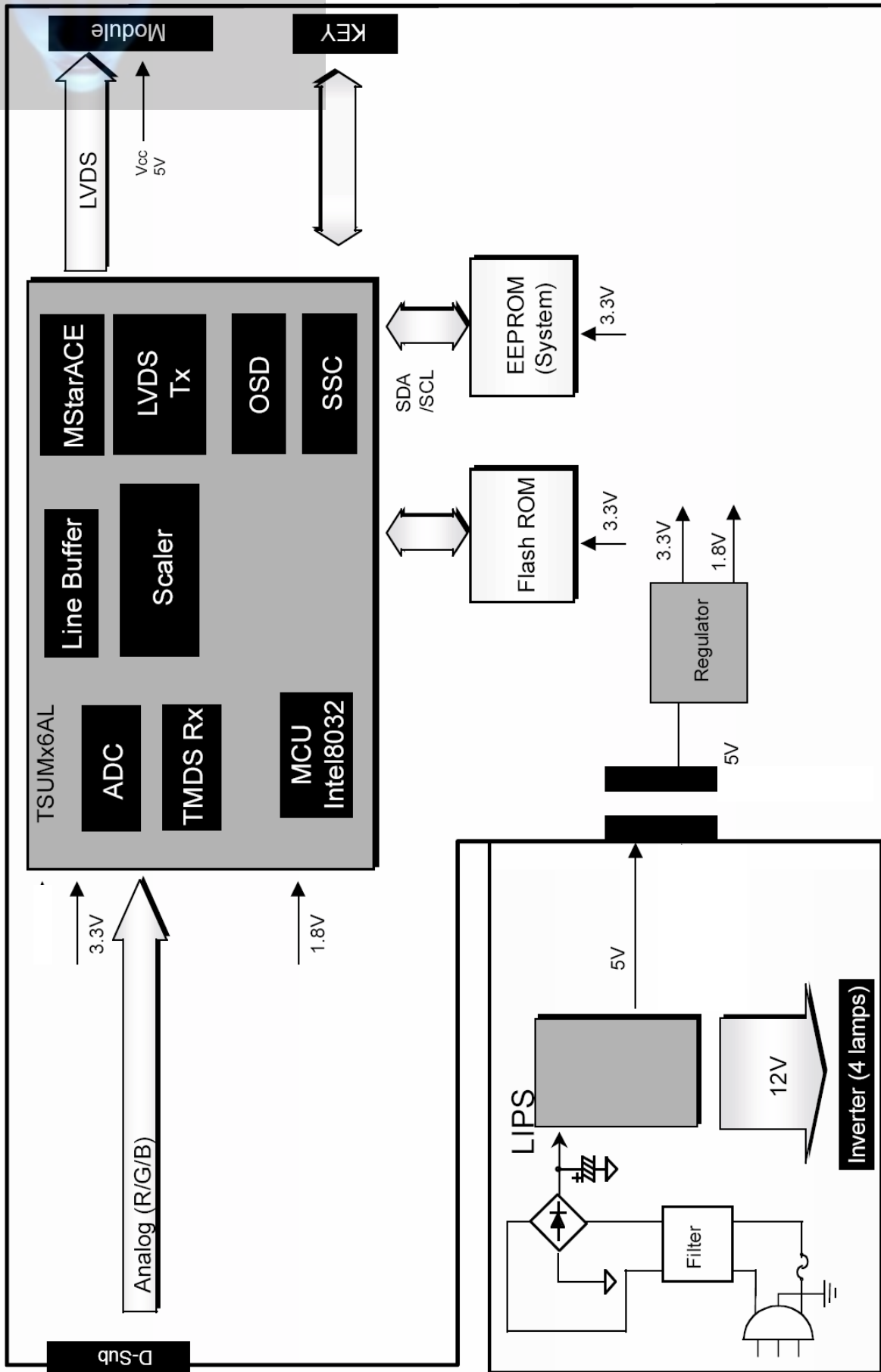

BLOCK DIAGRAM-POWER

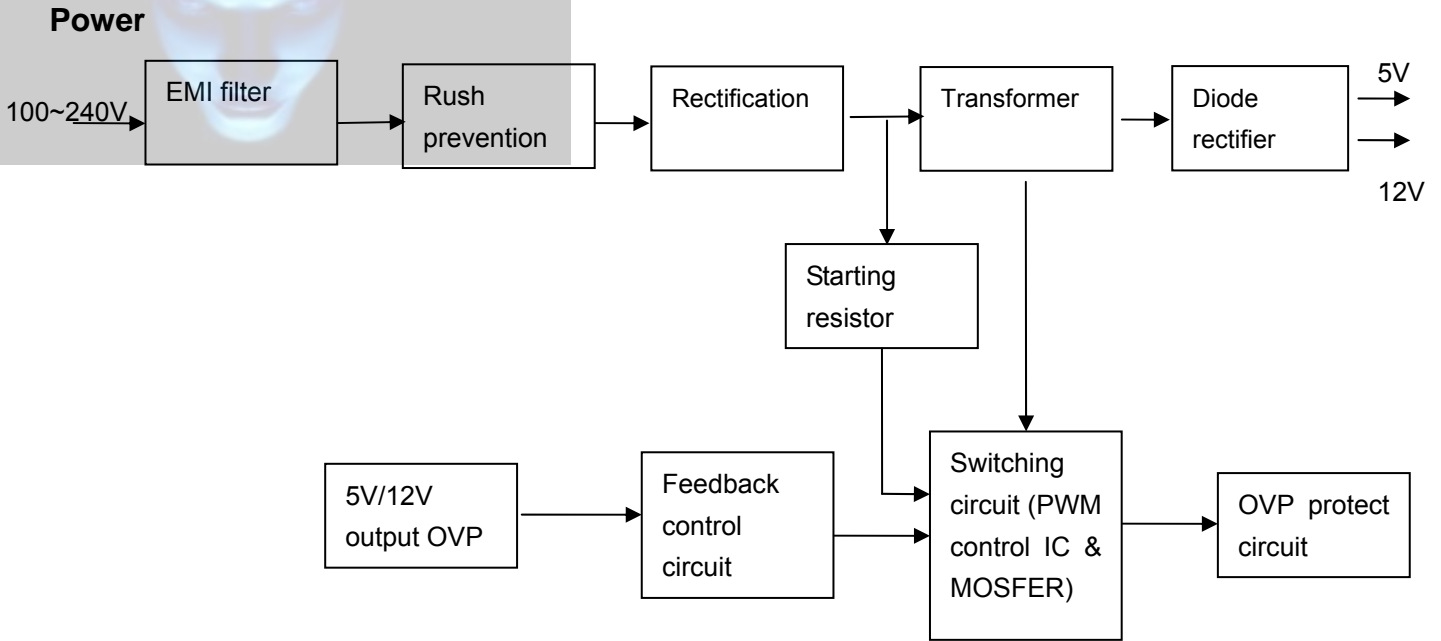

Inverter

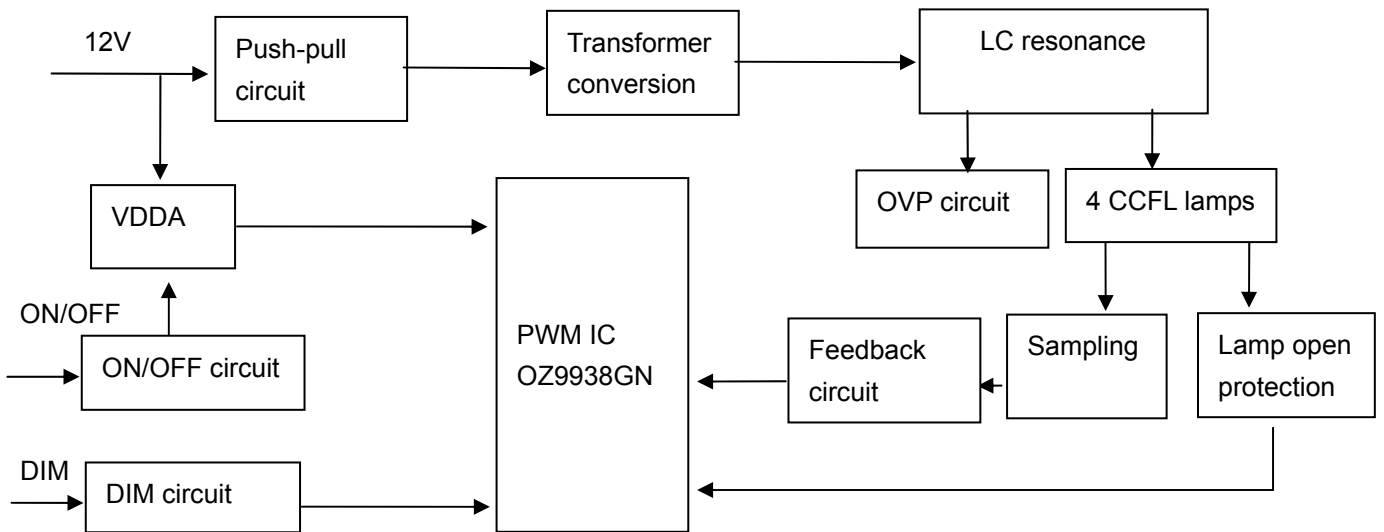



DESCRIPTION OF BLOCK DIAGRAM

1. Video Controller Part.

This part amplifies the level of video signal for the digital conversion and converts from the analog video signal to the digital video signal using a pixel clock.

The pixel clock for each mode is generated by the PLL.

The range of the pixel clock is from 25MHz to 135MHz.

This part consists of the Scaler, ADC converter, TMDS receiver and LVDS transmitter.

The Scaler gets the video signal converted analog to digital, interpolates input to 1280 X 1024 resolution signal and outputs 8-bit R, G, B signal to transmitter.

2. Power Part.

This part consists of the one 3.3V, and one 1.8V regulators to convert power which is provided 5V in Power board.

12V is provided for inverter, 5V is provided for LCD panel.

Also, 5V is converted 3.3V and 1.8V by regulator. Converted power is provided for IC in the main board.

The inverter converts from DC 12V to AC 700Vrms and operates back-light lamps of module.

3. MICOM Part.

This part is including video controller part. And this part consists of EEPROM IC which stores control data, Reset IC and the Micom.

The Micom distinguishes polarity and frequencies of the H/V sync are supplied from signal cable.

The controlled data of each mode is stored in EEPROM.

LIPS Board Block Diagram

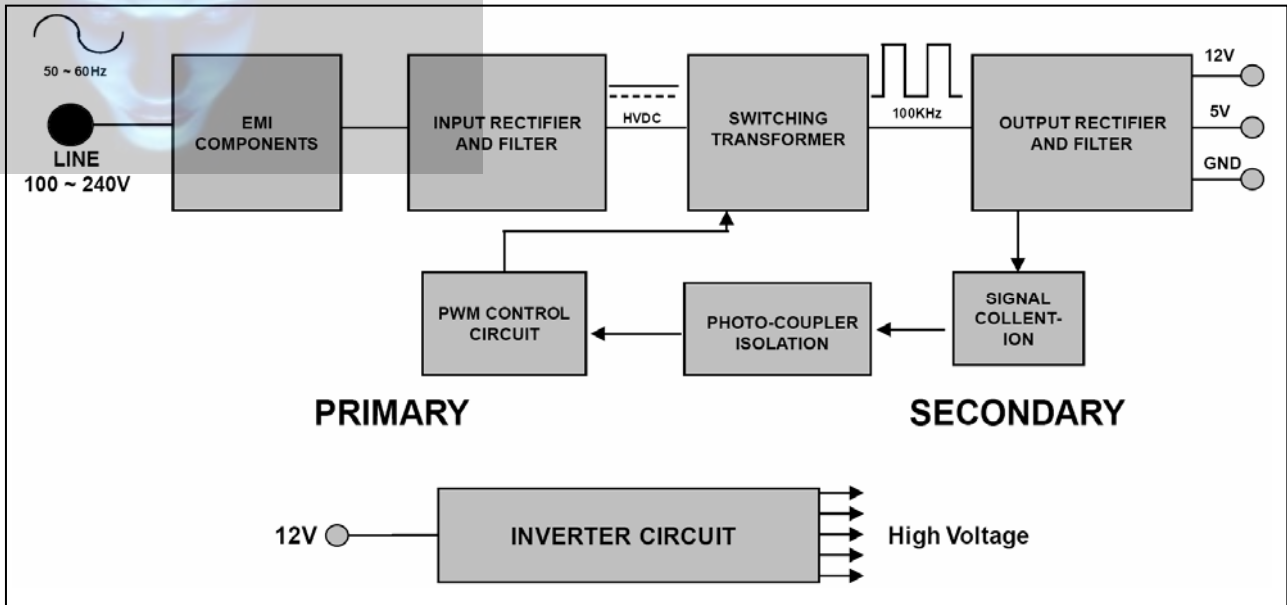

Operation description_LIPS

1. EMI components.

This part contains of EMI components to comply with global marketing EMI standards like FCC,VCCI CISPR, the circuit included a line-filter, across line capacitor and of course the primary protection fuse.

2. Input rectifier and filter.

This part function is for transfer the input AC voltage to a DC voltage through a bridge rectifier and a bulk capacitor.

3. Energy Transfer.

This part function is for transfer the primary energy to secondary through a power transformer.

4. Output rectifier and filter.

This part function is to make a pulse width modulation control and to provide the driver signal to power switch, to adjust the duty cycle during different AC input and output loading condition to achieve the dc output stabilized, and also the over power protection is also monitor by this part.

5. Photo-Coupler isolation.

This part function is to feed back the DC output changing status through a photo transistor to primary controller to achieve the stabilized DC output voltage.

6. Signal collection.

This part function is to collect the any change from the DC output and feed back to the primary through photo transistor.

ADJUSTMENT

Windows EDID V1.0 User Manual

Operating System: MS Windows 98, 2000, XP
 Port Setup: Windows 98 => Doesn't need setup
 Windows 2000, XP => Need to Port Setup.

This program is available for LCD Monitor only.

1. Port Setup

- a) Copy "UserPort.sys" file to "c:\WINNT\system32\drivers" folder
- b) Run Userport.exe

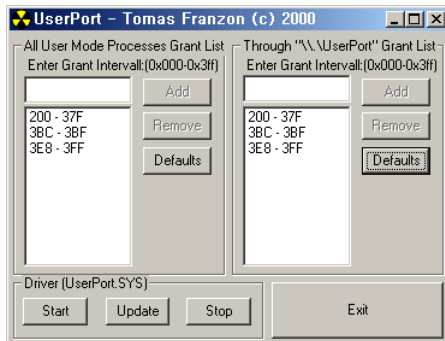

- c) Remove all default number
- d) Add 300-3FF

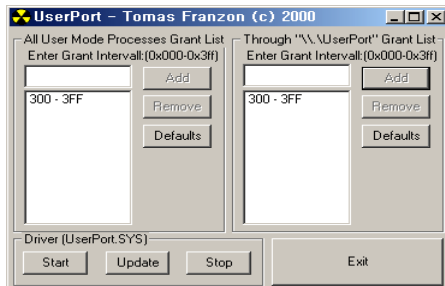

- e) Click Start button.
- f) Click Exit button.

2. EDID Read & Write

1) Run WinEDID.exe

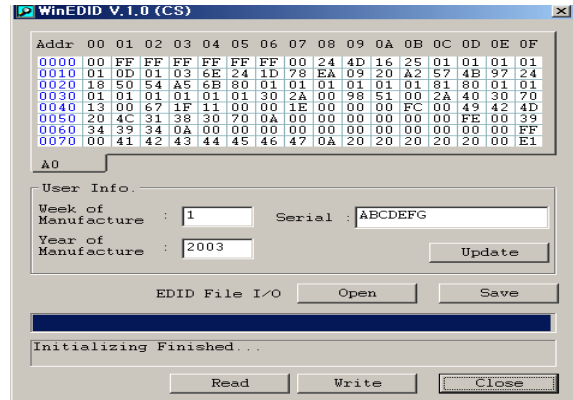

2) Edit Week of Manufacture, Year of Manufacture, Serial Number

- a) Input User Info Data
- b) Click "Update" button
- c) Click "Write" button

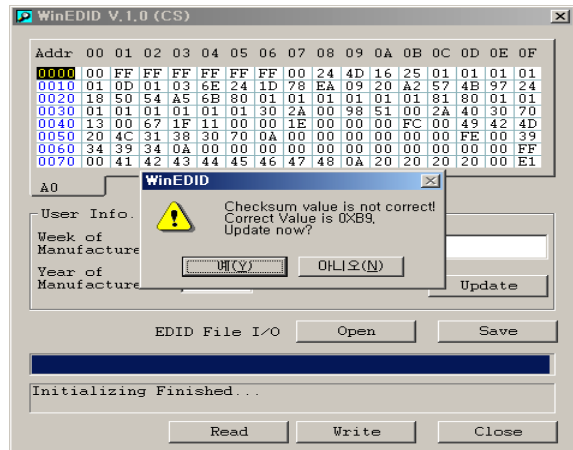

SERVICE MODE

- 1) Turn off the power switch at the front side of the display.
- 2) Wait for about 5 seconds and press MENU, POWER switch with 1 second interval.
- 3) The SVC OSD menu contains additional menus that the User OSD menu as described below.

- a) CLEAR ETI: To initialize using time.
- b) Auto Color: W/B balance and automatically sets the gain and offset value.
- c) AGING: Select Aging mode (on/off).
- d) PANEL: used panel type
- e) NVRAM INIT: EEPROM initialize. (24C08)
- f) R/G/B-9300K: Allows you to set the R/G/B-9300K value manually.
- g) R/G/B-6500K: Allows you to set the R/G/B-6500K value manually.
- h) R/G/B-Offset: Allows you to set the R/G/B-Offset value manually. (Analog Only)
- i) R/G/B-Gain: Allows you to set the R/G/B-Gain value manually. (Analog Only)

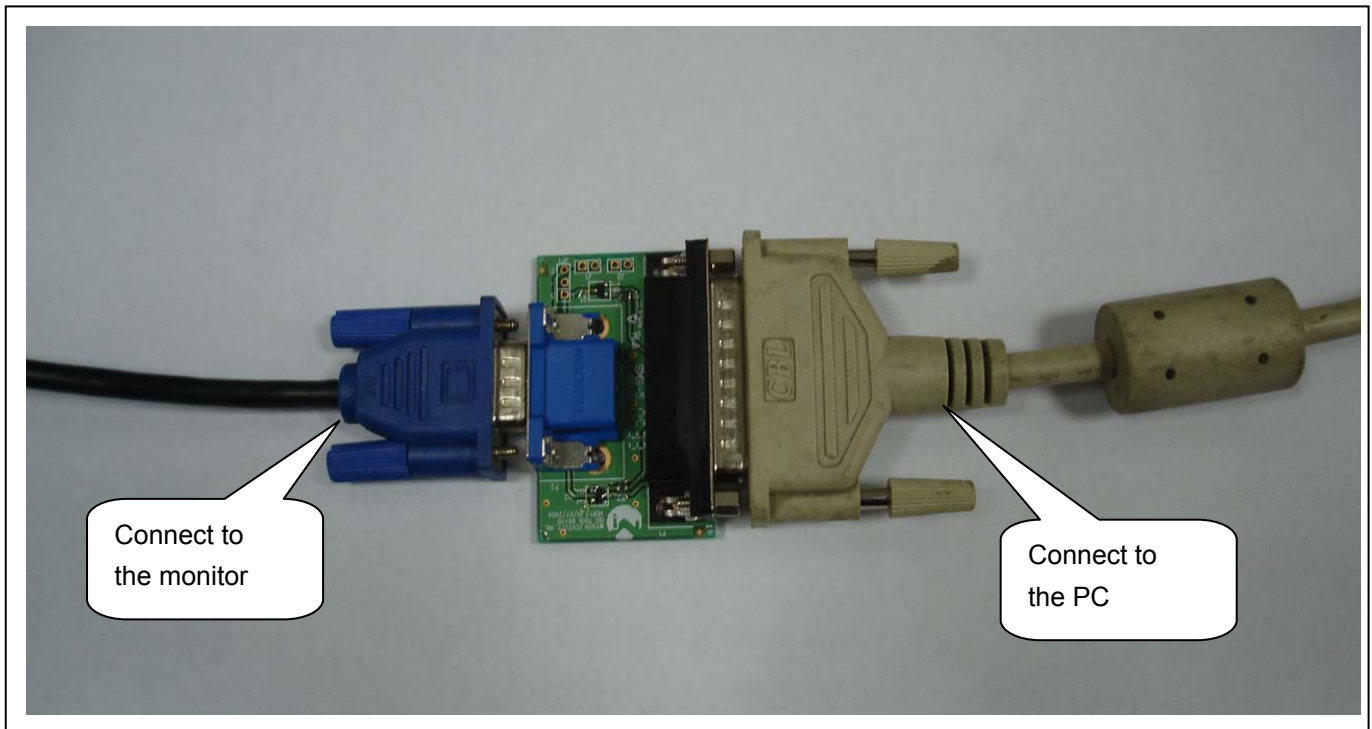
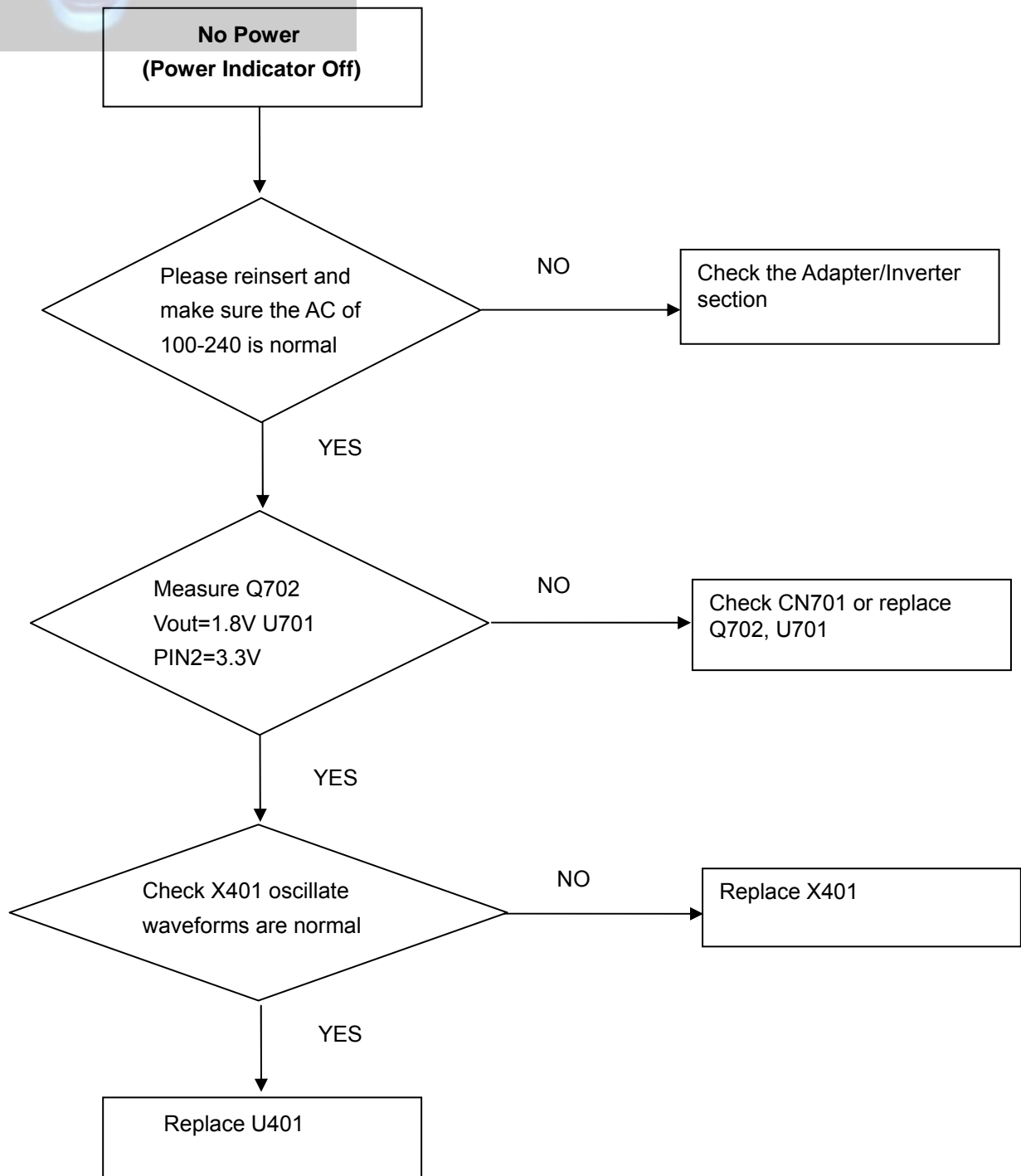

Figure 1. Cable Connection for Micom uploading

TROUBLESHOOTING GUIDE

1. NO POWER



2. NO RASTER (OSD IS NOT DISPLAY)-LIPS

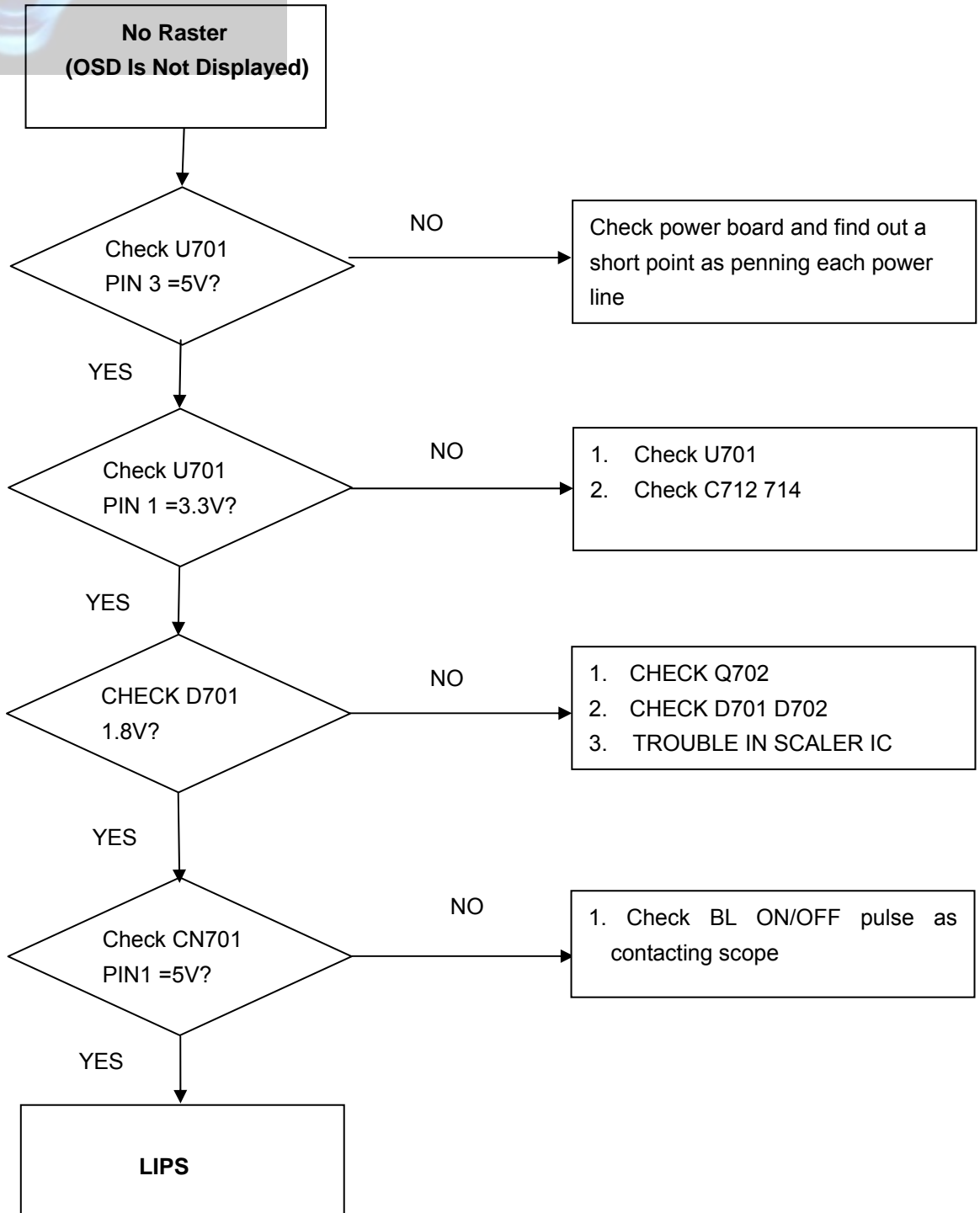

2. NO RASTER (OSD IS NOT DISPLAY)-MSTAR

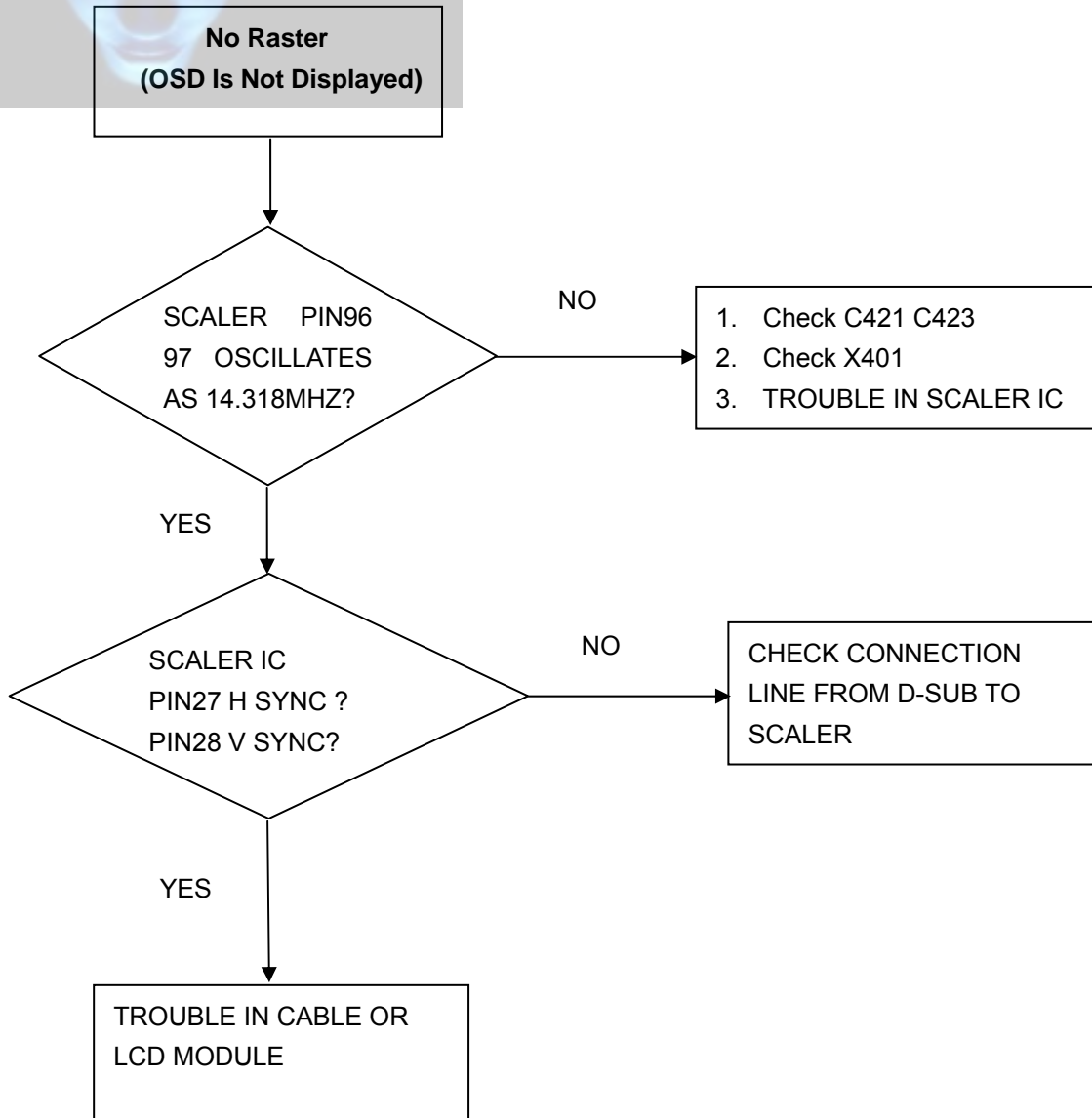

4. TROUBLE IN DPM

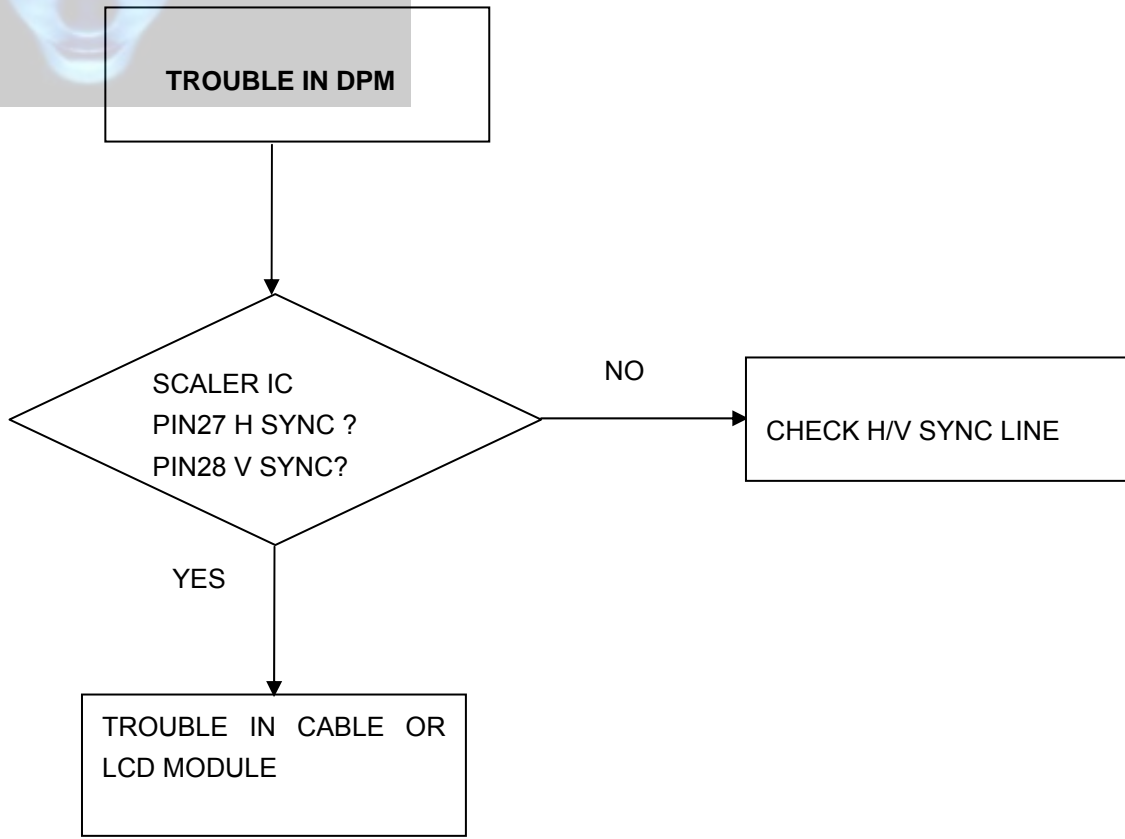

5. POWER

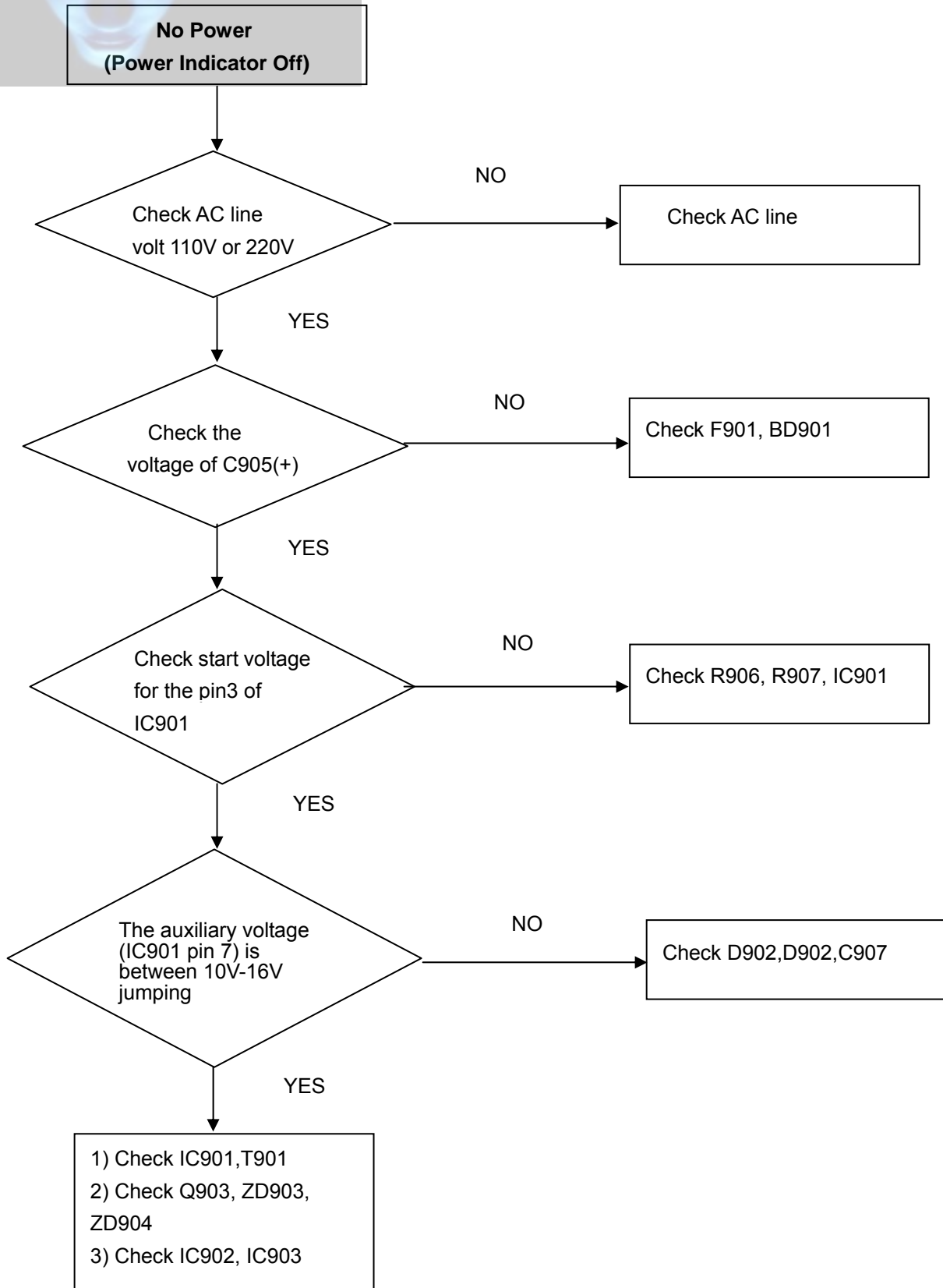

6. RASTER

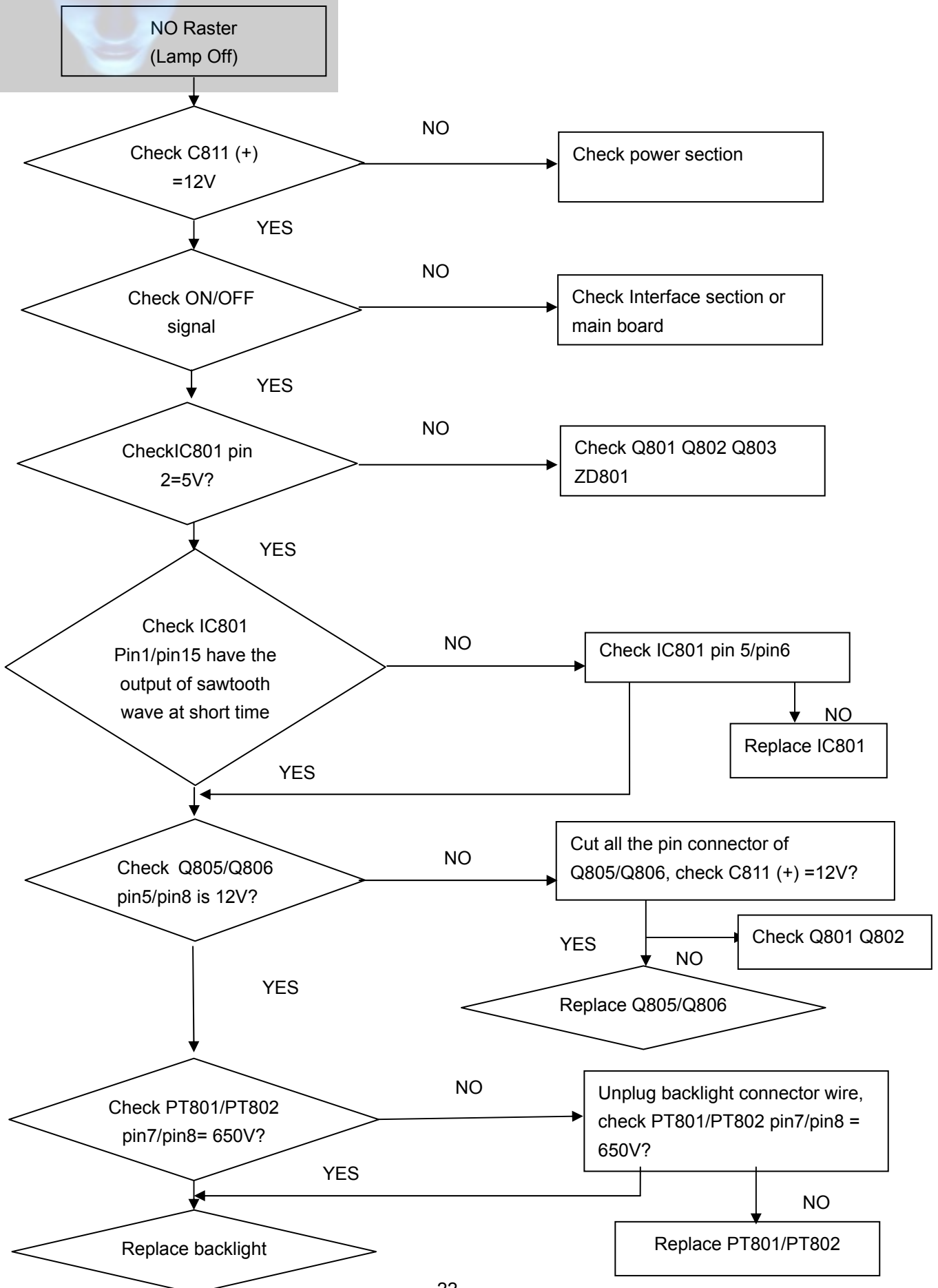



WIRING DIAGRAM

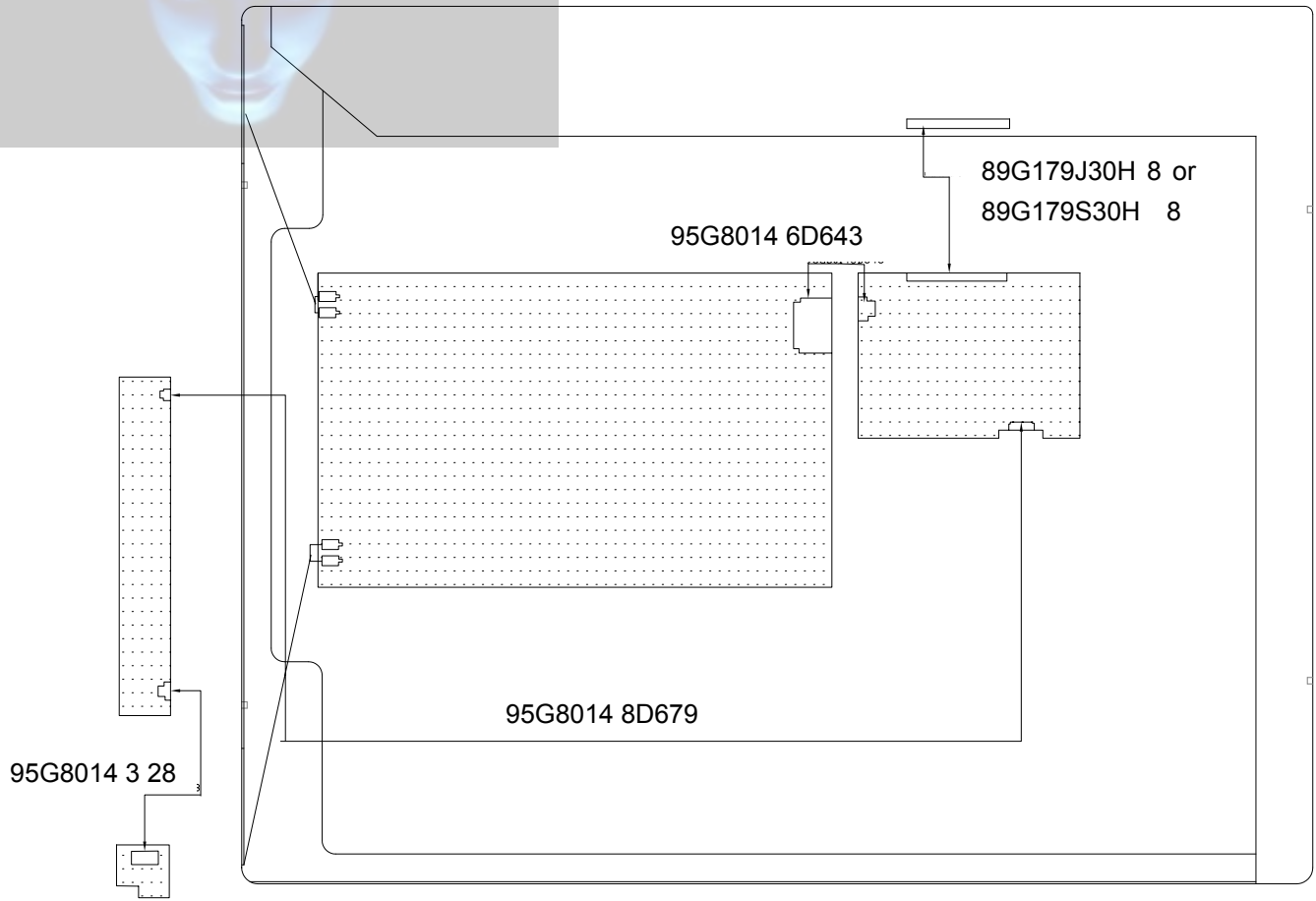



EXPLODED VIEW

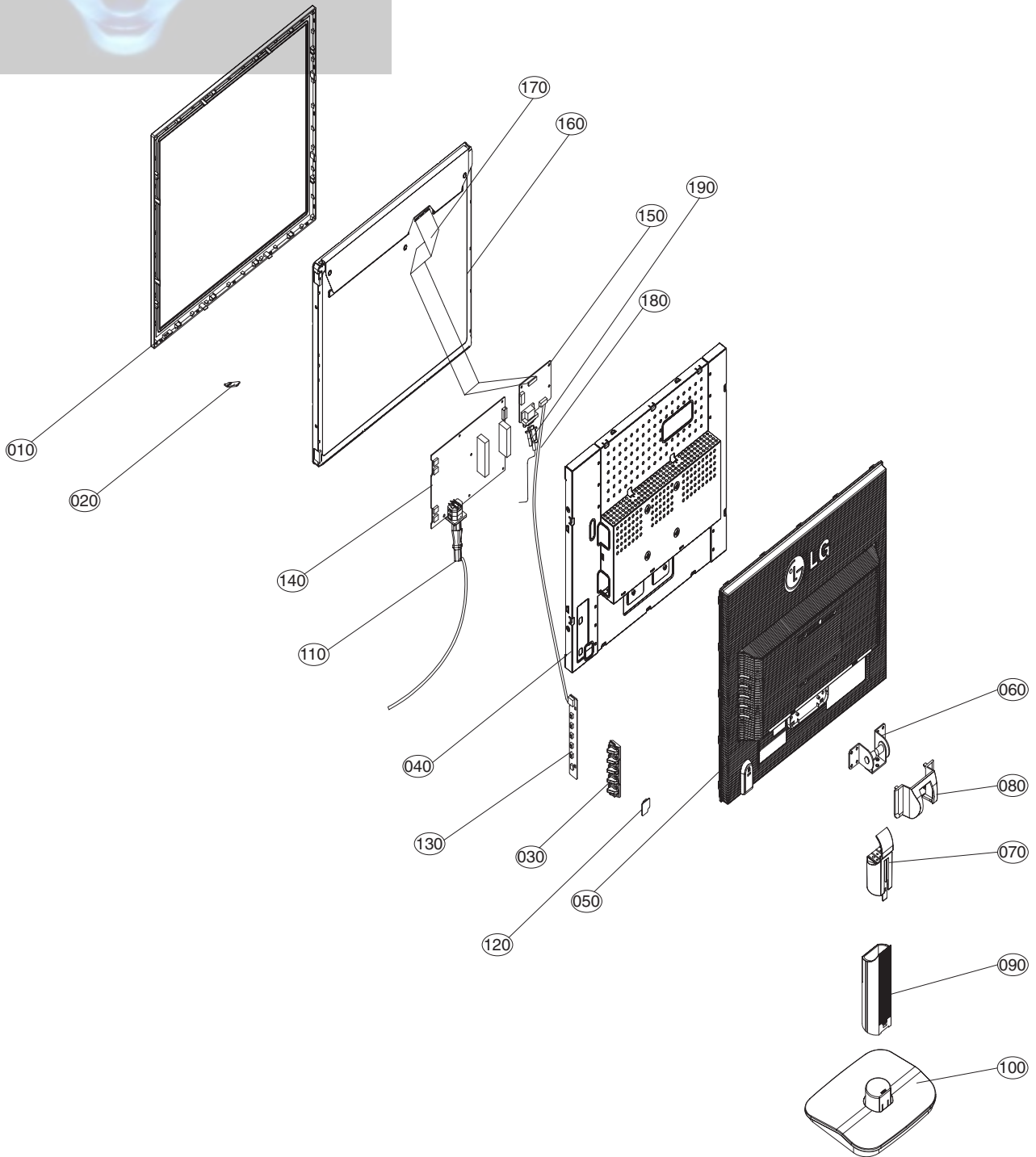

EXPLODED VIEW PARTS LIST

Ref. No.	TPV part no.	LGE part no.	Description
010	A34G0212ABNA1B	ABJ33041502	Bezel (Front cabinet) Silver color
	A34G0212 B6A1B	ABJ33041501	Bezel (Front cabinet) Black color
020	A33G0135 1 1C	MKC37803901	POWER LENS
030	A33G0134-B6 1L	MEY37805401	KEY BUTTON
040	A15G0163-4	ADV33042601	MAIN FRAME for LPL TLB2
	A15G0163 5	ADV33042603	MAIN FRAME for LPL TLL1/3 , HSD A01
	A15G0163-3	ADV33042602	MAIN FRAME for HSD D10
050	A34G0213-B6 1B 30	MCK37805801	REAR COVER
060	A37G0024 1	AGU33042901	HINGE
070	A33G0136-B6 1L	MCK37806001	HINGE BASE
080	A33G0137-B6 1L	MCK37806101	HINGE COVER
090	A34G0214-B6 1B 32	MCK37806301	STAND
100	A34G0215-B6 1B 33	MCK37806501	BASE
110	89G421A-18N-IS	6410TEW003A	PWRCORD BLK 6FT For Europe/Thailand/Vietnam/Russia/U.A.E
	89G402A18NIS	6410TUW008A	PWR CORD BLK 6FT For USA/Mexico/Panama/Canada
	89G410A-18N-IS	6410TBW004A	PWR CORD 10A/250V BLK 6FT UK for UK/Malaysia
	89G420A-18N-IS	6410TTW001A	PWR CORD BLK 6ft For Taiwan
	89G412A-18N-IS3	6410TSW003A	PWR CORD BLK 6ft For Australia
120	PTPC6AA1	EBU36839301	LED BOARD
130	KEPC6AAB	EBU36839101	KEY BOARD
140	PWPC942LL1P	EBU36838201	POWER BOARD for LPL
	PWPC942HL1P	EBU36848401	POWER BOARD for HSD
150	CBPC6GM9LMA1	EBU36837701	MAIN BOARD for LPL TLB2
	CBPC7GM9LMQ1	EBU38799401	MAIN BOARD for LPL TLL1/3
	CBPC6HM9LMA1	EBU36848301	MAIN BOARD for HSD D10
	CBPC7HM9LMQ1	EBU41521601	MAIN BOARD for HSD A01
160	750GLG90E8B21M000K	EBU36839801	LPL PANEL LM190E08-TLB2
	750GLG90E8L12M000K	EBU38798501	LPL PANEL LM190E08-TLL1
	750GLG90E8L32M000K	EBU38798901	LPL PANEL LM190E08-TLL3
	750GLH9013D12N	EBU36839901	HSD PANEL HSD190ME13-D10
	750GLH90N3A22N	EBU41521801	HSD PANEL HSD190MEN3-A01
170	89G179S30H 8	EBU36839601	LVDS CABLE
180	95G8014 8D679	EBU36839501	KEY BOARD HARNESS
190	89G728HAA 2G	EBU41369001	SIGNAL CABLE

REPLACEMENT PARTS LIST

CAUTION: BEFORE REPLACING ANY OF THESE COMPONENTS,
READ CAREFULLY THE **SAFETY PRECAUTIONS** IN THIS MANUAL.
MAIN BOARD AND POWER BOARD PARTS ARE DIFFERENT.

* NOTE : **S** SAFETY Mark 
AL ALTERNATIVE PARTS

DATE: 2006. 12. 21.

*S	*AL	LOC. NO.	PART NO.	DESCRIPTION
MAIN BOARD				
CAPACITORS				
		C702	067G215Y479 7NV	LOW ESR EC 4.7 UF 50V NC
		C702	067G215Y4797RV	EC 105°C CAP 4.7UF M 50V
		C717	067G305V100 3	10UF +-20% 16V
		C712	067G305V100 3	10UF +-20% 16V
		C710	067G305V100 3	10UF +-20% 16V
		C418	067G305V100 3	10UF +-20% 16V
		C408	067G305V100 3	10UF +-20% 16V
		C403	067G305V100 3	10UF +-20% 16V
		C435	065G0603102 32	1000PF +-10% 50V X7R
		C441	065G0603104 12	CER2 0603 X7R 16V 100N P
		C440	065G0603104 12	CER2 0603 X7R 16V 100N P
		C439	065G0603104 12	CER2 0603 X7R 16V 100N P
		C430	065G0603104 12	CER2 0603 X7R 16V 100N P
		C429	065G0603104 12	CER2 0603 X7R 16V 100N P
		C425	065G0603104 12	CER2 0603 X7R 16V 100N P
		C422	065G0603104 12	CER2 0603 X7R 16V 100N P
		C444	065G0603104 12	CER2 0603 X7R 16V 100N P
		C445	065G0603104 12	CER2 0603 X7R 16V 100N P
		C709	065G0603104 12	CER2 0603 X7R 16V 100N P
		C713	065G0603104 12	CER2 0603 X7R 16V 100N P
		C714	065G0603104 12	CER2 0603 X7R 16V 100N P
		C715	065G0603104 12	CER2 0603 X7R 16V 100N P
		C718	065G0603104 12	CER2 0603 X7R 16V 100N P
		C419	065G0603104 12	CER2 0603 X7R 16V 100N P
		C401	065G0603104 12	CER2 0603 X7R 16V 100N P
		C402	065G0603104 12	CER2 0603 X7R 16V 100N P
		C404	065G0603104 12	CER2 0603 X7R 16V 100N P
		C405	065G0603104 12	CER2 0603 X7R 16V 100N P
		C406	065G0603104 12	CER2 0603 X7R 16V 100N P
		C407	065G0603104 12	CER2 0603 X7R 16V 100N P
		C409	065G0603104 12	CER2 0603 X7R 16V 100N P
		C410	065G0603104 12	CER2 0603 X7R 16V 100N P
		C411	065G0603104 12	CER2 0603 X7R 16V 100N P
		C412	065G0603104 12	CER2 0603 X7R 16V 100N P

		C413	065G0603104 12	CER2 0603 X7R 16V 100N P
		C414	065G0603104 12	CER2 0603 X7R 16V 100N P
		C415	065G0603104 12	CER2 0603 X7R 16V 100N P
		C416	065G0603104 12	CER2 0603 X7R 16V 100N P
		C443	065G0603220 31	CER1 0603 NP0 50V 22P PM
		C442	065G0603220 31	CER1 0603 NP0 50V 22P PM
		C423	065G0603220 31	CER1 0603 NP0 50V 22P PM
		C421	065G0603220 31	CER1 0603 NP0 50V 22P PM
		C417	065G0603224 12	CAP CHIP 0603 220N 16V X7R +/-10%
		C426	065G0603331 32	CHIP 330PF 50V X7R
		C427	065G0603331 32	CHIP 330PF 50V X7R
		C428	065G0603331 32	CHIP 330PF 50V X7R
		C431	065G0603331 32	CHIP 330PF 50V X7R
		C446	065G0603331 32	CHIP 330PF 50V X7R
		C438	065G0603473 32	CHIP 0.047UF 50V X7R
		C437	065G0603473 32	CHIP 0.047UF 50V X7R
		C436	065G0603473 32	CHIP 0.047UF 50V X7R
		C434	065G0603473 32	CHIP 0.047UF 50V X7R
		C433	065G0603473 32	CHIP 0.047UF 50V X7R
		C432	065G0603473 32	CHIP 0.047UF 50V X7R
DIODEs				
		D415	093G 39147	TZMC5V6
		D413	093G 39147	TZMC5V6
		D412	093G 39147	TZMC5V6
		D411	093G 39147	TZMC5V6
		D410	093G 39147	TZMC5V6
		D409	093G 39147	TZMC5V6
		D408	093G 39147	TZMC5V6
		D406	093G 39147	TZMC5V6
		D415	093G 39147SEM	ZMM5V6ST
		D413	093G 39147SEM	ZMM5V6ST
		D412	093G 39147SEM	ZMM5V6ST
		D411	093G 39147SEM	ZMM5V6ST
		D410	093G 39147SEM	ZMM5V6ST
		D409	093G 39147SEM	ZMM5V6ST
		D408	093G 39147SEM	ZMM5V6ST
		D406	093G 39147SEM	ZMM5V6ST
		D407	093G 64 42 P	BAV70 SOT-23
		D407	093G 64 42 PP	BAV70 SOT-23
		D414	093G 6432P	LL4148
		D701	093G 6432P	LL4148
		D702	093G 6432P	LL4148
		D405	093G 6433P	BAV99
		D404	093G 6433P	BAV99
		D403	093G 6433P	BAV99

		D403	093G 6433S	DIODE BAV99 SEMTECH
		D404	093G 6433S	DIODE BAV99 SEMTECH
		D405	093G 6433S	DIODE BAV99 SEMTECH
		D702	093G 64S522SEM	LL4148
		D701	093G 64S522SEM	LL4148
		D414	093G 64S522SEM	LL4148
		D704	093G2004 2	SR24/PANJIT-SMT
		D704	093G2004 2A	SM240A DO-214AC
IC				
		U401	056G 562105	TSUM16AL-LF
		U701	056G 585 4	IC AIC1117-33PYTR-R AIC
		U701	056G 585 4A	AP1117E33LA
		U403	056G1133 32	IC M24C04-WMN6TP SO8
		U404	056G1133 34 1	IC M24C02-RMN6TP 2Kb SO-8
		U402	LLGM9S9GNQ1	SST25VF010A-33-4C-SAE
		U403	056G1133104	IC AF24BC04-SI 4K SOIC-8
TRANSISTOR				
		Q703	057G 417 4	PMBS3904/PHILIPS-SMT(04)
		Q402	057G 417 4	PMBS3904/PHILIPS-SMT(04)
		Q401	057G 417 6	PMBS3906/PHILIPS-SMT(06)
		Q403	057G 417 6	PMBS3906/PHILIPS-SMT(06)
		Q706	057G 417 6	PMBS3906/PHILIPS-SMT(06)
		Q402	057G 417 12 T	KEC 2N3904S-RTK/PS
		Q703	057G 417 12 T	KEC 2N3904S-RTK/PS
		Q706	057G 417 13 T	KEC 2N3906S-RTK/PS
		Q403	057G 417 13 T	KEC 2N3906S-RTK/PS
		Q401	057G 417 13 T	KEC 2N3906S-RTK/PS
		Q702	057G 417 17 T	PZT2907A
		Q702	057G 41717B T	tra PZT2907A PHILIPS
		Q704	057G 763 1	A03401 SOT23 BY AOS(A1)
		Q704	057G 763 1A	AP2305N
RESISTORs				
		R706	061G0603000	RST CHIPR 0 OHM +-5% 1/10W
		R721	061G0603000	RST CHIPR 0 OHM +-5% 1/10W
		R704	061G0603101	RST CHIPR 100 OHM +-5% 1/10W
		R478	061G0603101	RST CHIPR 100 OHM +-5% 1/10W
		R454	061G0603101	RST CHIPR 100 OHM +-5% 1/10W
		R453	061G0603101	RST CHIPR 100 OHM +-5% 1/10W
		R445	061G0603101	RST CHIPR 100 OHM +-5% 1/10W
		R443	061G0603101	RST CHIPR 100 OHM +-5% 1/10W
		R442	061G0603101	RST CHIPR 100 OHM +-5% 1/10W
		R441	061G0603101	RST CHIPR 100 OHM +-5% 1/10W
		R429	061G0603101	RST CHIPR 100 OHM +-5% 1/10W
		R428	061G0603101	RST CHIPR 100 OHM +-5% 1/10W
		R427	061G0603101	RST CHIPR 100 OHM +-5% 1/10W

	R414	061G0603101	RST CHIPR 100 OHM +-5% 1/10W
	R409	061G0603101	RST CHIPR 100 OHM +-5% 1/10W
	R486	061G0603102	RST CHIP 1K 1/10W 5%
	R477	061G0603102	RST CHIP 1K 1/10W 5%
	R476	061G0603102	RST CHIP 1K 1/10W 5%
	R475	061G0603102	RST CHIP 1K 1/10W 5%
	R474	061G0603102	RST CHIP 1K 1/10W 5%
	R455	061G0603102	RST CHIP 1K 1/10W 5%
	R447	061G0603102	RST CHIP 1K 1/10W 5%
	R446	061G0603102	RST CHIP 1K 1/10W 5%
	R480	061G0603103	RST CHIPR 10 KOHM +-5% 1/10W
	R481	061G0603103	RST CHIPR 10 KOHM +-5% 1/10W
	R482	061G0603103	RST CHIPR 10 KOHM +-5% 1/10W
	R483	061G0603103	RST CHIPR 10 KOHM +-5% 1/10W
	R484	061G0603103	RST CHIPR 10 KOHM +-5% 1/10W
	R485	061G0603103	RST CHIPR 10 KOHM +-5% 1/10W
	R708	061G0603103	RST CHIPR 10 KOHM +-5% 1/10W
	R711	061G0603103	RST CHIPR 10 KOHM +-5% 1/10W
	R714	061G0603103	RST CHIPR 10 KOHM +-5% 1/10W
	R717	061G0603103	RST CHIPR 10 KOHM +-5% 1/10W
	R727	061G0603103	RST CHIPR 10 KOHM +-5% 1/10W
	R701	061G0603103	RST CHIPR 10 KOHM +-5% 1/10W
	R404	061G0603103	RST CHIPR 10 KOHM +-5% 1/10W
	R406	061G0603103	RST CHIPR 10 KOHM +-5% 1/10W
	R408	061G0603103	RST CHIPR 10 KOHM +-5% 1/10W
	R413	061G0603103	RST CHIPR 10 KOHM +-5% 1/10W
	R415	061G0603103	RST CHIPR 10 KOHM +-5% 1/10W
	R416	061G0603103	RST CHIPR 10 KOHM +-5% 1/10W
	R424	061G0603103	RST CHIPR 10 KOHM +-5% 1/10W
	R425	061G0603103	RST CHIPR 10 KOHM +-5% 1/10W
	R426	061G0603103	RST CHIPR 10 KOHM +-5% 1/10W
	R444	061G0603103	RST CHIPR 10 KOHM +-5% 1/10W
	R452	061G0603103	RST CHIPR 10 KOHM +-5% 1/10W
	R479	061G0603103	RST CHIPR 10 KOHM +-5% 1/10W
	R728	061G0603151	RST CHIPR 150 OHM +-5% 1/10W
	R729	061G0603151	RST CHIPR 150 OHM +-5% 1/10W
	R703	061G0603202	RST CHIPR 2 KOHM +-5% 1/10W
	R405	061G0603203	RST CHIPR 20 KOHM +-5% 1/10W
	R449	061G0603222	RST CHIPR 2.2 KOHM +-5% 1/10W
	R448	061G0603222	RST CHIPR 2.2 KOHM +-5% 1/10W
	R403	061G0603390 0F	RST CHIPR 390 OHM +-1% 1/10W
	R419	061G0603470	RST CHIPR 47 OHM +-5% 1/10W
	R421	061G0603470	RST CHIPR 47 OHM +-5% 1/10W
	R487	061G0603470	RST CHIPR 47 OHM +-5% 1/10W
	R488	061G0603470	RST CHIPR 47 OHM +-5% 1/10W

	R437	061G0603471	RST CHIPR 470 OHM +-5% 1/10W
	R451	061G0603472	RST CHIPR 4.7KOHM +-5% 1/10W
	R450	061G0603472	RST CHIPR 4.7KOHM +-5% 1/10W
	R725	061G0603472	RST CHIPR 4.7KOHM +-5% 1/10W
	R712	061G0603472	RST CHIPR 4.7KOHM +-5% 1/10W
	R705	061G0603472	RST CHIPR 4.7KOHM +-5% 1/10W
	R423	061G0603472	RST CHIPR 4.7KOHM +-5% 1/10W
	R422	061G0603472	RST CHIPR 4.7KOHM +-5% 1/10W
	R702	061G0603510	RST CHIPR 51 OHM +-5% 1/10W
	R723	061G0603513	RST CHIPR 51 KOHM +-5% 1/10W
	R436	061G0603560	RST CHIPR 56 OHM +-5% 1/10W
	R435	061G0603560	RST CHIPR 56 OHM +-5% 1/10W
	R434	061G0603560	RST CHIPR 56 OHM +-5% 1/10W
	R438	061G0603750 9F	RST CHIPR 75 OHM +-1% 1/10W
	R439	061G0603750 9F	RST CHIPR 75 OHM +-1% 1/10W
	R440	061G0603750 9F	RST CHIPR 75 OHM +-1% 1/10W
COILs & FILTERs			
	FB401	071G 56Z601	CHIP BEAD 600 OHM 0805
	FB402	071G 56Z601	CHIP BEAD 600 OHM 0805
	FB403	071G 56Z601	CHIP BEAD 600 OHM 0805
	FB404	071G 56Z601	CHIP BEAD 600 OHM 0805
	FB405	071G 56Z601	CHIP BEAD 600 OHM 0805
	FB406	071G 56Z601	CHIP BEAD 600 OHM 0805
	FB409	071G 59B121	TB160808B
	FB412	071G 59K300 B	CHIP BEAD FCB1608KF-300T07 bullwill
	FB411	071G 59K300 B	CHIP BEAD FCB1608KF-300T07 bullwill
	FB410	071G 59K300 B	CHIP BEAD FCB1608KF-300T07 bullwill
OTHERs			
	CN701	033G3802 6 J GP	WAFER
	CN102	33G801930D BH JS	LVDS SOCKET
	CN403	33G8043 8 H	WAFER 2*4P 2.0MM
	CN405	088G 35315F H	D-SUB 15PIN
	X401	093G 22 53	CRYSTAL 14.318MHzHC-49US
POWER BOARD			
CAPACITORS			
	C903	063G 10747410S	CAPACITANCE
	C825	065G 3J1006ET	10PF,J,3KV,SL
	C816	065G 3J1006ET	10PF,J,3KV,SL
	C824	065G 3J3096ET	3PF,J,3KV,Z5P
	C826	065G 3J3096ET	3PF,J,3KV,Z5P
	C900	065G306M1022B3	Y1 CAP 1000PF M 250VAC TDK
	C901	065G306M1022B3	Y1 CAP 1000PF M 250VAC TDK
	C902	065G306M1022B3	Y1 CAP 1000PF M 250VAC TDK
	C902	065G306M1022BP	1000PF Y1.CAP

	C901	065G306M1022BP	1000PF Y1.CAP
	C900	065G306M1022BP	1000PF Y1.CAP
	C924	067G215V471 4H	470UF 25V
	C923	067G215V471 4H	470UF 25V
	C922	067G215V471 4H	470UF 25V
	C921	067G215V471 4H	470UF 25V
	C920	067G215V471 4H	470UF 25V
	C915	067G215V471 4H	470UF 25V
	C815	067G215V471 4H	470UF 25V
	C811	067G215V471 4H	470UF 25V
	C925	067G215S10915V 3964	EC CAP 1.0uF 450V 8*11mm
	C905	067G315Y10115H	EC.100UF 450V 20*34mm
	C808	061G0805184	RST CHIPR 180 KOHM +-5% 1/8W
	C813	065G0805102 31	1000PF 50V NPO
	C812	065G0805102 31	1000PF 50V NPO
	C807	065G0805103 32	10NF/50V/0805/X7R
	C910	065G0805103 32	10NF/50V/0805/X7R
	C919	065G0805104 32	CHIP 0.1U 50V X7R
	C918	065G0805104 32	CHIP 0.1U 50V X7R
	C913	065G0805104 32	CHIP 0.1U 50V X7R
	C908	065G0805104 32	CHIP 0.1U 50V X7R
	C904	065G0805104 32	CHIP 0.1U 50V X7R
	C832	065G0805104 32	CHIP 0.1U 50V X7R
	C829	065G0805104 32	CHIP 0.1U 50V X7R
	C828	065G0805104 32	CHIP 0.1U 50V X7R
	C822	065G0805104 32	CHIP 0.1U 50V X7R
	C821	065G0805104 32	CHIP 0.1U 50V X7R
	C817	065G0805104 32	CHIP 0.1U 50V X7R
	C802	065G0805104 32	CHIP 0.1U 50V X7R
	C801	065G0805104 32	CHIP 0.1U 50V X7R
	C830	065G0805105 22	CHIP 1UF 25V X7R 0805
	C804	065G0805105 22	CHIP 1UF 25V X7R 0805
	C806	065G0805105 22	CHIP 1UF 25V X7R 0805
	C909	065G0805221 31	220PF 50V NPO
	C820	065G0805222 31	0805 2200PF
	C827	065G0805222 31	0805 2200PF
	C831	065G0805222 31	0805 2200PF
	C805	065G0805222 31	0805 2200PF
	C818	065G0805222 31	0805 2200PF
	C814	065G0805224 22	CAIP CAP 0.22 uF 25V X7R
	C810	065G0805471 31	CHIP 470PF 50V NPO
	C809	065G0805473 32	CHIP 0.047UF 50V X7R
	C819	065G0805473 32	CHIP 0.047UF 50V X7R
	C905	006G 31502	1.5MM RIVET

		C903	006G 31502	1.5MM RIVET
		C934	065G 2K152 1T GP	CERAMIC CAP
		C931	065G 2K152 1T GP	CERAMIC CAP
		C930	065G 2K152 1T GP	CERAMIC CAP
		C914	065G 2K152 1T GP	CERAMIC CAP
		C912	065G 2K152 1T GP	CERAMIC CAP
		C907	067G 5152207HT	CAP 105°C 22UF M 50V
		C907	067G215Y2207KT	ED 105°C 22UF M 50V KINGNICH
DIODEs				
		BD901	093G 50460900	BRIDGE DIODE GBU408 LITEON
		D907	093G 60245	SP10150
		D906	093G 60267	SP10100
		D806	093G 64 33	DIO SIG SM BAV99 (PHSE)R
		D805	093G 64 33	DIO SIG SM BAV99 (PHSE)R
		D804	093G 64 33	DIO SIG SM BAV99 (PHSE)R
		D803	093G 64 33	DIO SIG SM BAV99 (PHSE)R
		D802	093G 64 33	DIO SIG SM BAV99 (PHSE)R
		D801	093G 64 33	DIO SIG SM BAV99 (PHSE)R
		D904	093G 6432S	IN4148W
		D807	093G 6432S	IN4148W
		D808	093G 6432S	IN4148W
		D809	093G 6432S	IN4148W
		D810	093G 6432S	IN4148W
		D811	093G 6432S	IN4148W
		ZD801	093G 39S 24 T	RLZ 5.6B LLDS
		ZD902	093G 39S 24 T	RLZ 5.6B LLDS
		ZD903	093G 39S 38 T	PTZ 9.1B
		ZD901	093G 39S 40 T	RLZ 13B LLDS
		ZD906	093G 39S 42 T	RLZ27B LLDS
		ZD904	093G 39S 44 T	RLZ18B LLDS
		D801	093G 6433S	DIODE BAV99 SEMTECH
		D802	093G 6433S	DIODE BAV99 SEMTECH
		D803	093G 6433S	DIODE BAV99 SEMTECH
		D804	093G 6433S	DIODE BAV99 SEMTECH
		D805	093G 6433S	DIODE BAV99 SEMTECH
		D806	093G 6433S	DIODE BAV99 SEMTECH
		D904	093G 64S511SEM	IN4148W
		D807	093G 64S511SEM	IN4148W
		D808	093G 64S511SEM	IN4148W
		D809	093G 64S511SEM	IN4148W
		D810	093G 64S511SEM	IN4148W

	D811	093G 64S511SEM	IN4148W
	D905	093G 5212T52T	DIODE 1N4007 DO-41
	D901	093G 6026T52T	RECTIFIER DIODE FR107
	D902	093G 6038T52T	FR103
	D901	093G 6026W52T	FR107
TRANSISTORS & ICS			
	IC902	056G 139 3A	PC123Y22FZOF
	IC901	056G 379 79	IC LD7522PS SOP-8
	IC801	056G 608 10	OZ9938
	IC903	056G 158 10 T	IC AZ431AZ-AE1 TO-92 BY AAC
	Q903	057G 667516	FET 2SK3673 TO-220 FUJI
	Q801	057G 417 4	PMBS3904/PHILIPS-SMT(04)
	Q802	057G 417 4	PMBS3904/PHILIPS-SMT(04)
	Q803	057G 417 4	PMBS3904/PHILIPS-SMT(04)
	Q810	057G 759 2	RK7002
	Q809	057G 759 2	RK7002
	Q808	057G 759 2	RK7002
	Q807	057G 759 2	RK7002
	Q804	057G 759 2	RK7002
	Q805	057G 763 14	AM9945N
	Q806	057G 763 14	AM9945N
	Q801	057G 417 12 T	KEC 2N3904S-RTK/PS
	Q802	057G 417 12 T	KEC 2N3904S-RTK/PS
	Q803	057G 417 12 T	KEC 2N3904S-RTK/PS
	Q805	057G 763 6	AO4828L
	Q806	057G 763 6	AO4828L
	Q903	006G 31502	1.5MM RIVET
RESISTORS			
	R905	061G152M10458F	100K OHM 5% 2W
	R914	061G152M43858F	RST MOFR 0.43OHM +-5% 2WS
	NR901	061G 58005 W	RST NTCR 5 OHM 3A THINKING
	JR801	061G0805000	0 OHM 1/10W
	JR821	061G0805000	0 OHM 1/10W
	R921	061G0805102	CHIP 1KOHM 1/10W
	R922	061G0805102	CHIP 1KOHM 1/10W
	R926	061G0805102	CHIP 1KOHM 1/10W
	R843	061G0805102	CHIP 1KOHM 1/10W
	R836	061G0805102	CHIP 1KOHM 1/10W
	R812	061G0805103	10 KOHM 1/10W
	R927	061G0805103	10 KOHM 1/10W
	R806	061G0805103	10 KOHM 1/10W
	R804	061G0805103	10 KOHM 1/10W
	R803	061G0805103	10 KOHM 1/10W
	R815	061G0805104	RST CHIP 100K 1/8W 5%
	R844	061G0805105	1MOHM 1/10W

	R840	061G0805105	1MOHM 1/10W
	R839	061G0805105	1MOHM 1/10W
	R838	061G0805105	1MOHM 1/10W
	R820	061G0805105	1MOHM 1/10W
	R816	061G0805105	1MOHM 1/10W
	R813	061G0805105	1MOHM 1/10W
	R810	061G0805105	1MOHM 1/10W
	R913	061G0805114	RST CHIPR 110 KOHM +-5% 1/8W
	R908	061G0805202	RST CHIP 2K 1/8W 5%
	R924	061G0805240 1F	2.4KOHM 1/10W 1%
	R920	061G0805302	RST CHIPR 3 KOHM +-5% 1/8W
	R802	061G0805304	RST CHIPR 300 KOHM +-5% 1/8W
	R923	061G0805330 2F	33 KOHM 1/10W 1%
	R925	061G0805360 1F	3.6KOHM 1/10W 1%
	R826	061G0805361	RST CHIPR 360 OHM +-5% 1/8W
	R841	061G0805430 0F	RST CHIPR 430 OHM +-1% 1/8W
	R817	061G0805433	RST CHIPR 43 KOHM +-5% 1/8W
	R808	061G0805473	RST CHIPR 47 KOHM +-5% 1/8W
	R825	061G0805513	RST CHIPR 51 KOHM +-5% 1/8W
	R917	061G0805683	68K&8 1/10W
	R824	061G0805751	RST CHIPR 750 OHM +-5% 1/8W
	R858	061G0805751	RST CHIPR 750 OHM +-5% 1/8W
	R827	061G0805752	RST CHIPR 7.5 KOHM +-5% 1/8W
	R831	061G0805752	RST CHIPR 7.5 KOHM +-5% 1/8W
	R814	061G0805754	RST CHIPR 750 KOHM +-5% 1/8W
	R823	061G0805823	RST CHIPR 82 KOHM +-5% 1/8W
	R830	061G0805823	RST CHIPR 82 KOHM +-5% 1/8W
	JR904	061G1206000	0 OHM 1/8W
	JR903	061G1206000	0 OHM 1/8W
	JR902	061G1206000	0 OHM 1/8W
	JR824	061G1206000	0 OHM 1/8W
	JR823	061G1206000	0 OHM 1/8W
	JR822	061G1206000	0 OHM 1/8W
	JR820	061G1206000	0 OHM 1/8W
	R910	061G1206100	10 OHM 1/8W
	R931	061G1206101	100 1206
	R932	061G1206101	100 1206
	R933	061G1206101	100 1206
	R930	061G1206101	100 1206
	R916	061G1206101	100 1206
	R906	061G1206101	100 1206
	R912	061G1206103	10 KOHM 1/8W
	R919	061G1206151	RST CHIPR 150 OHM +-5% 1/4W
	R904	061G1206154	RST CHIP 150K 1/4W 5%
	R907	061G1206154	RST CHIP 150K 1/4W 5%

	R915	061G1206154	RST CHIP 150K 1/4W 5%	
	R807	061G1206220	RST CHIPR 22 OHM +-5% 1/4W	
	R911	061G1206221	RST CHIPR 220 OHM +-5% 1/4W	
	R909	061G1206249	RST CHIPR 2.4 OHM +-5% 1/4W	
	R801	061G1206330	RST CHIPR 33 OHM +-5% 1/4W	
	R818	061G1206330	RST CHIPR 33 OHM +-5% 1/4W	
	R928	061G1206335	RST CHIPR 3.3MOHM +-5% 1/4W	
	R929	061G1206335	RST CHIPR 3.3MOHM +-5% 1/4W	
	R934	061G1206335	RST CHIPR 3.3MOHM +-5% 1/4W	
	R805	061G1206471	470 1206	
	R835	061G1206472	RST CHIPR 4.7 KOHM +-5% 1/4W	
	R834	061G1206472	RST CHIPR 4.7 KOHM +-5% 1/4W	
	R833	061G1206472	RST CHIPR 4.7 KOHM +-5% 1/4W	
	R828	061G1206472	RST CHIPR 4.7 KOHM +-5% 1/4W	
	R837	061G1206519	RST CHIPR 5.1 OHM +-5% 1/4W	
	R842	061G1206519	RST CHIPR 5.1 OHM +-5% 1/4W	
	R901	061G1206684	RST CHIPR 680 KOHM +-5% 1/4W	
	R902	061G1206684	RST CHIPR 680 KOHM +-5% 1/4W	
	R903	061G1206684	RST CHIPR 680 KOHM +-5% 1/4W	
	NR901	006G 31502	1.5MM RIVET	
	R822	061G212Y625 KT	MGFR 6.2MOHM +-5% 1/2W	
	R832	061G212Y625 KT	MGFR 6.2MOHM +-5% 1/2W	
TRANSFORMER				
	PT801	080GL19T 8DN1	X'FMR DARFONTK.2006M.101	
	PT802	080GL19T 8DN1	X'FMR DARFONTK.2006M.101	
	T901	080GL19T 25 L	X'FMR 550uH PT-0076563-3	
	T901	080GL19T 25 YS	X'FMR 550uH YS04160073	
	PT802	S80GL19T8V1	TRANSFORMER ASS'Y	
	PT801	S80GL19T8V1	TRANSFORMER ASS'Y	
	T901	006G 31502	1.5MM RIVET	
	PT801	006G 31502	1.5MM RIVET	
	PT802	006G 31502	1.5MM RIVET	
OTHERs				
	CN801	033G8021 2E U	WAFER	
	CN802	033G8021 2E U	WAFER	
	CN803	033G8021 2E U	WAFER	
	CN804	033G8021 2E U	WAFER	
	CN901	087G 501 32 S	AC SOCKET	
	CN902	095G8014 6D643	WIRE HARNESS	
	CN901	006G 31500	EYELET	
	L904	073G 253 91 LS	CHOKE BY LI SHIN	
	L903	073G 253 91 LS	CHOKE BY LI SHIN	
	L901	073L 174 53 LG GP	CHOKE	
	L902	073L 174 55 LG GP	LINE FILTER BY LITAI	
	L902	073L 174 55LSG GP	LINE FILTER BY LISHIN	

		L902	S73L17455VG	TRANSFORMER ASS'Y
		L901	006G 31502	1.5MM RIVET
		L902	006G 31502	1.5MM RIVET
		F901	084G 33 10	FUSE CLIP
		F901	084G 41 3	3.15AH/250V
		FB901	071G 55 29	FERRITE BEAD



SCHEMATIC DIAGRAM

1. SCALER

TSUM16AL SCHEMATIC

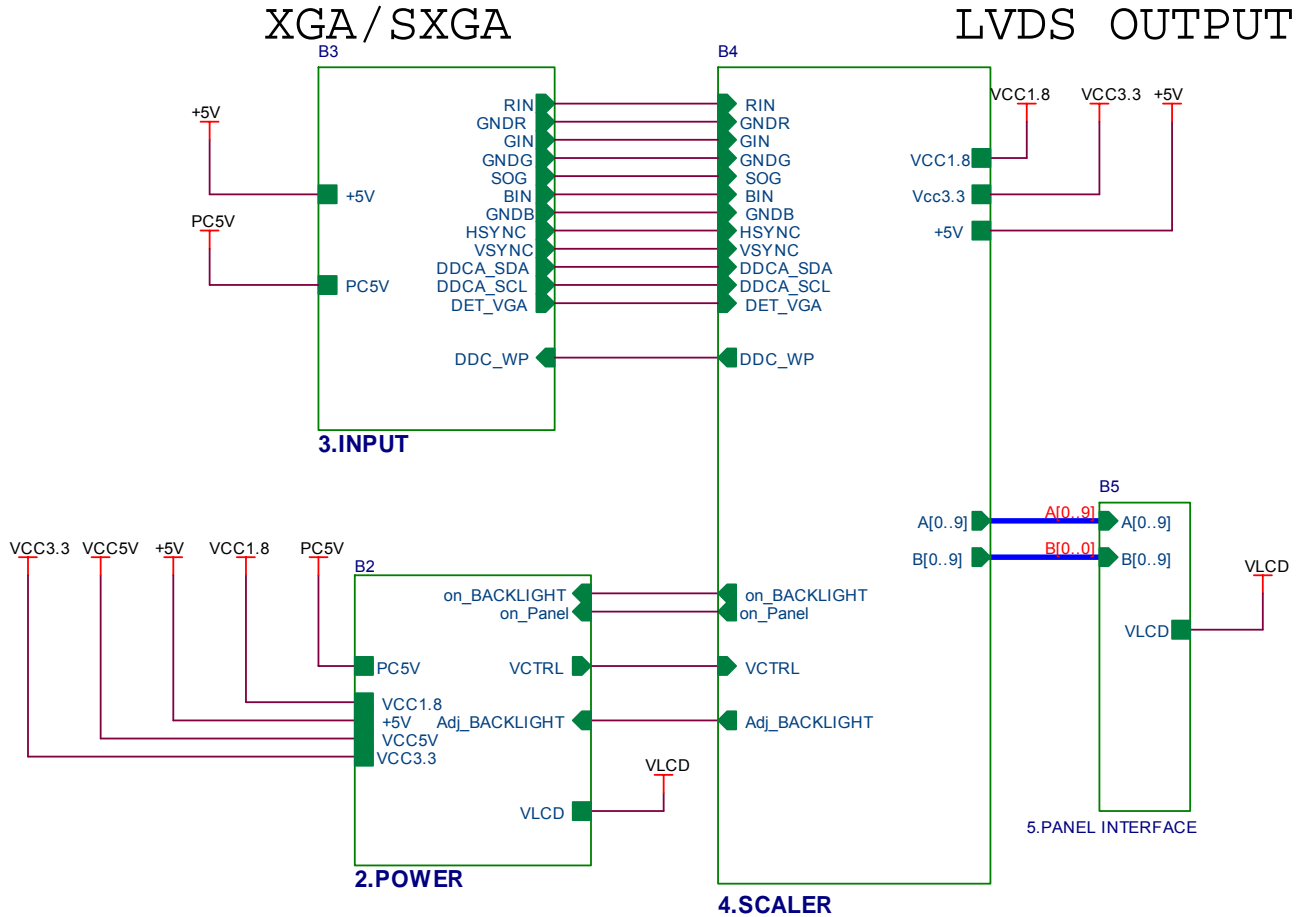

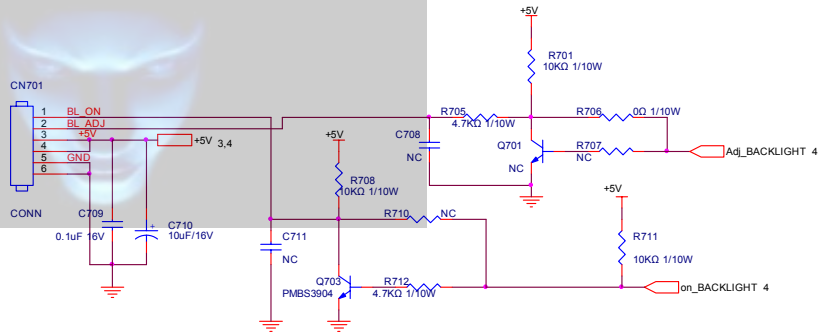

BL_ADJ(DC)	R704	C708	R704	R703	R703	Q701
0V - 3.3V	4.7K	1uF	0	X	X	X
0V - 5V	4.7K	1uF	X	3K	4.7K	MMBT3904

BL_ADJ	R705	C708
P M M	47	N.C
D C	4K7	1uF

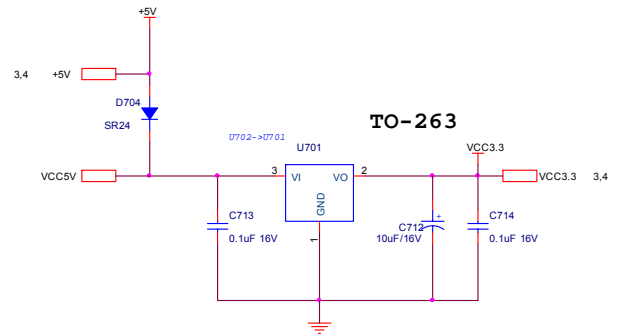
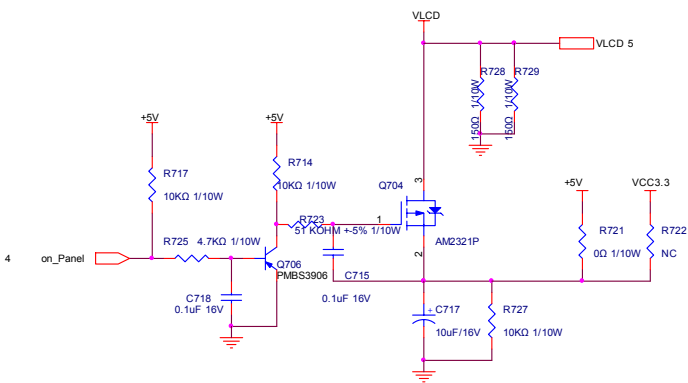
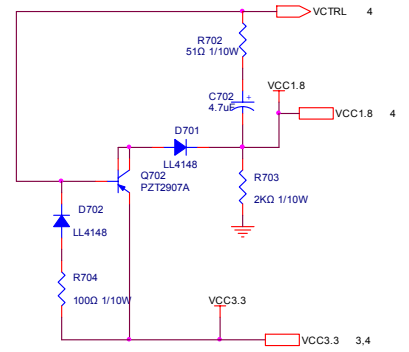

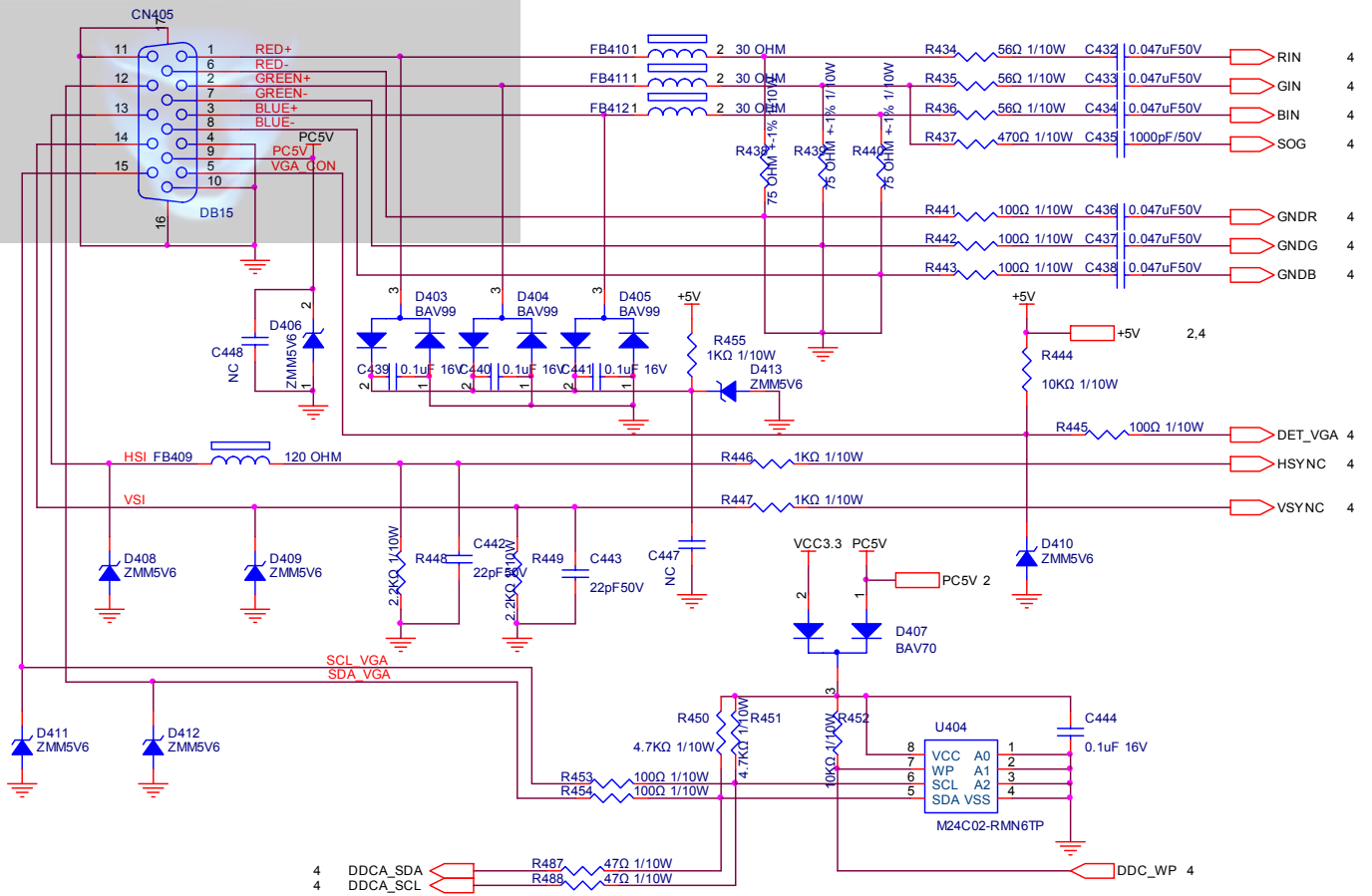

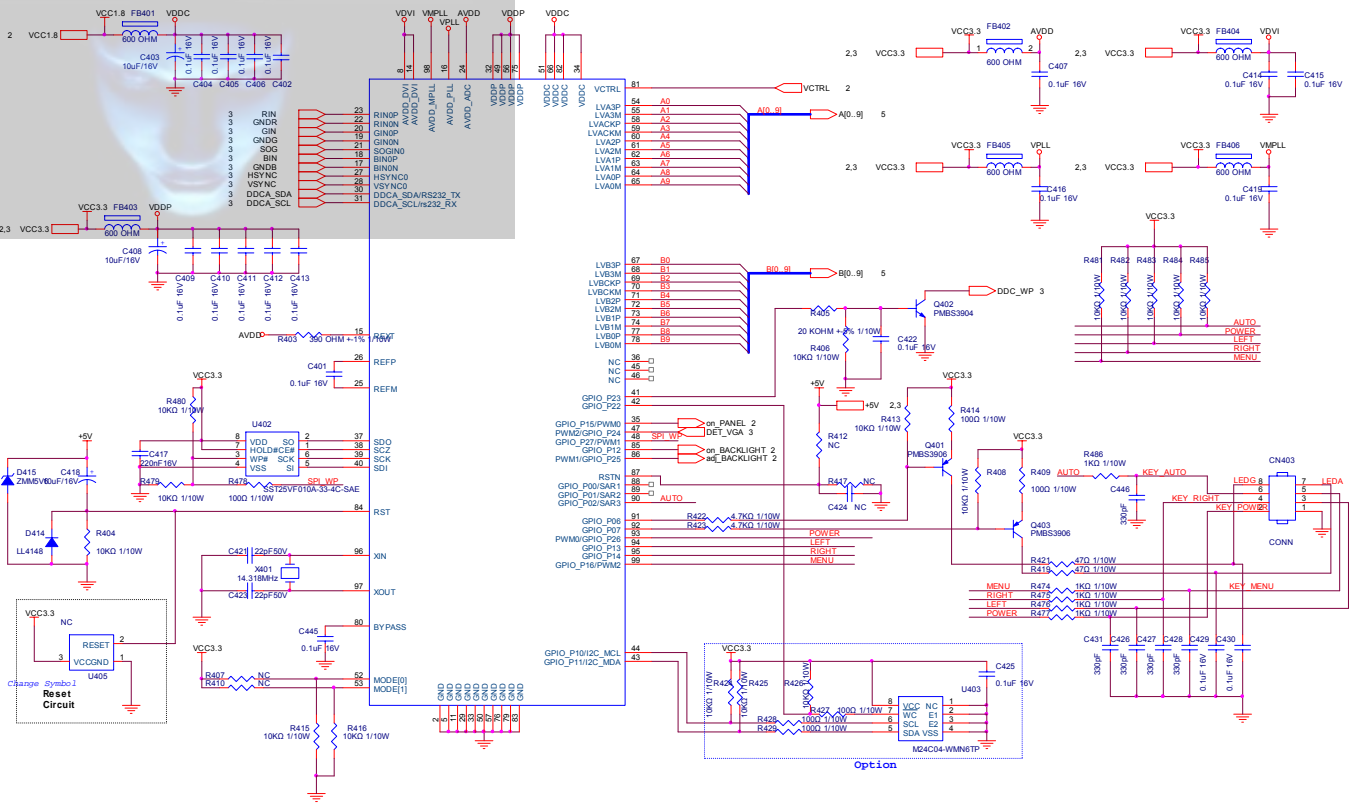

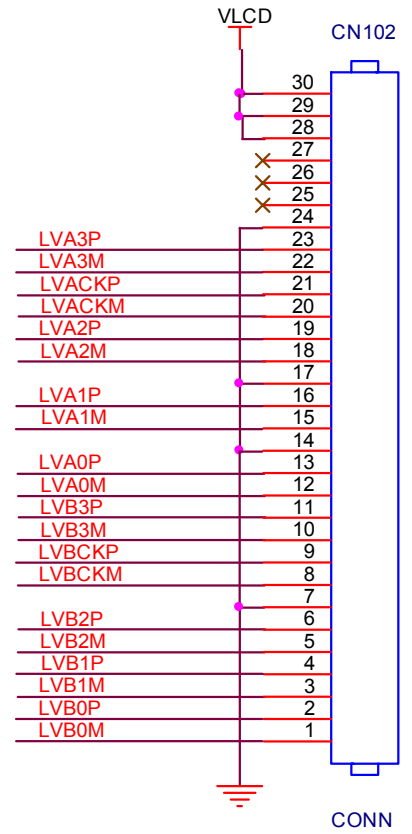
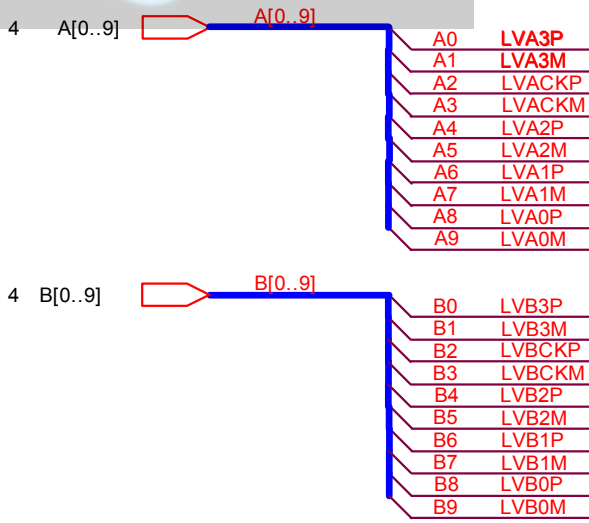

2. INVERTER

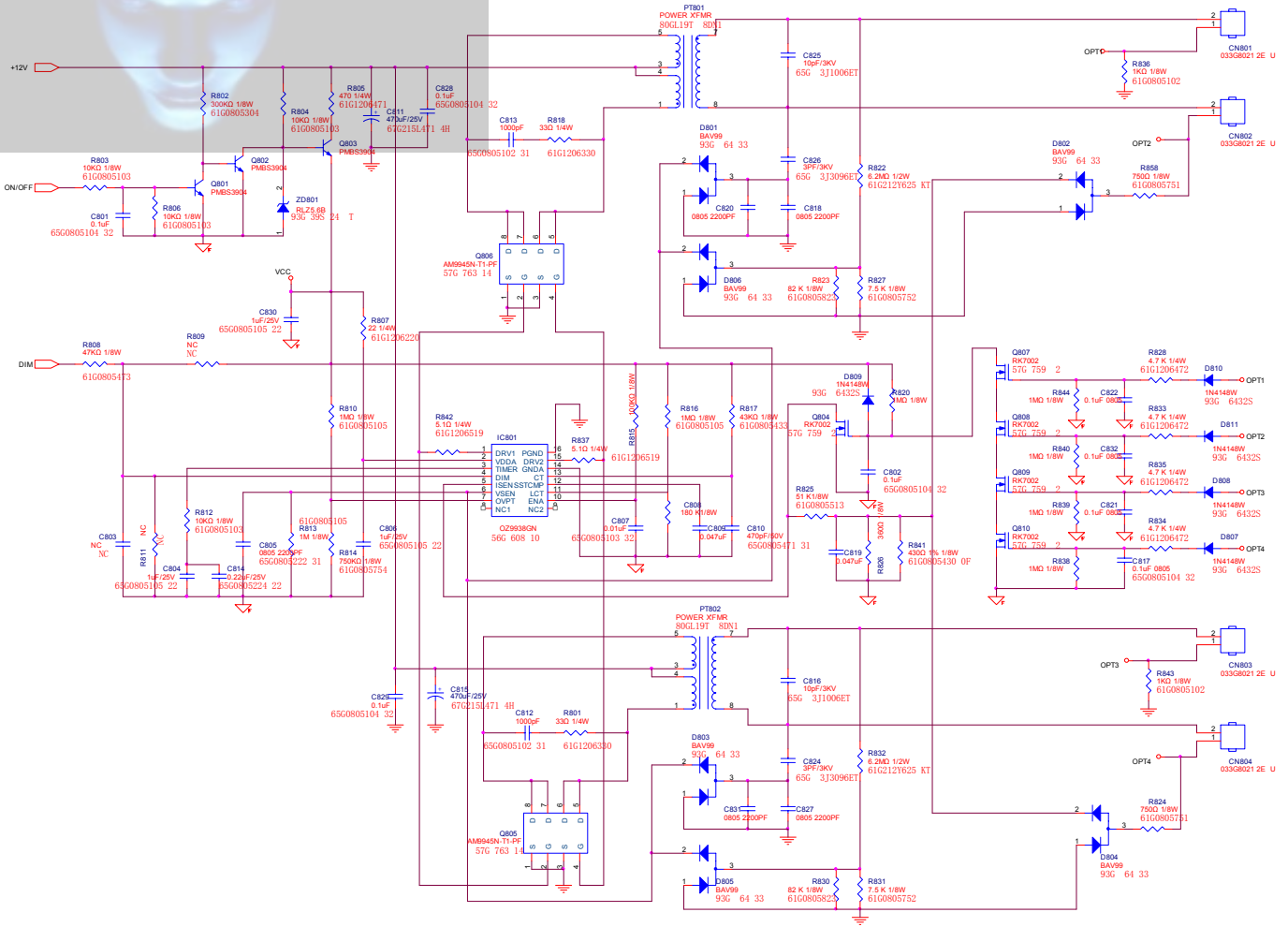

3. POWER

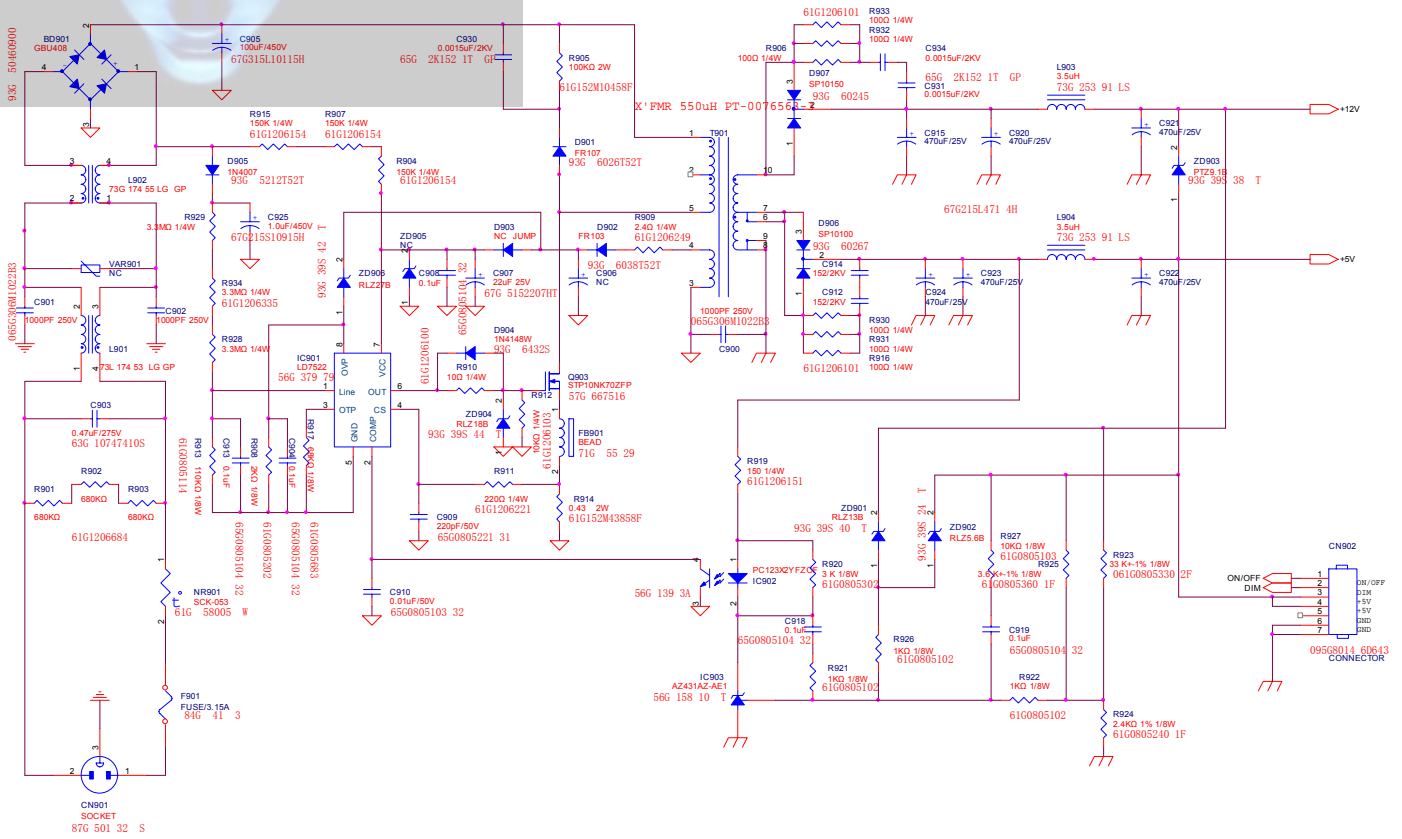

BT FORUM



P/NO : MFL36713631

Jan. 2007
Printed in China