

CTX CHUNTEX
OPUS
ENGINEERING SPECIFICATION

RD

NO. ES-032

1765D

1765GM

1785D

1785GM

VL-700

CONTENTS

1. Scope	2	<i>CPS-1760DF</i>
2. Input Requirements.....	2	
3. Electrical Characteristics.....	3	<i>1760D</i>
4. Visual Characteristics.....	5	
5. Mechanical Characteristics	8	<i>1760DF</i>
6. Environmental Requirements.....	9	
7. Safety Requirements.....	9	
8. Reliability	10	
9. Appendix A	12	

ENGINEERING SPECIFICATION

CONTENTS

1. Scope	2		
2. Input Requirements	2		
3. Electrical Characteristics.....	3		
3.1 Picture Tube.....	3	3.4 Scanning Characteristics	4
3.2 Switching Power Supply	3	3.5 Power Saving	4
3.3 Video Characteristics	3	3.6 Plug & Play.....	4
4. Visual Characteristics.....	5		
4.1 Standard Test Condition	5	4.10 Brightness Uniformity	6
4.2 Picture Size	5	4.11 Pixel Movement	6
4.3 Picture Position.....	5	4.12 Gray Scale	7
4.4 Non-linearity.....	5	4.13 Light Output	7
4.5 Picture Distortion	5	4.14 Light Output VS Time	7
4.6 Misconvergence	5	4.15 Thermal Stability	7
4.7 Focus	6	4.16 Acoustic Noise.....	7
4.8 Size Stability	6	4.17 Turn Off	7
4.9 White Balance.....	6	4.18 High Voltage Discharge	7
5. Mechanical Characteristics	8		
6. Environmental Requirements	9		
6.1 Operating	9	6.3 Dielectric Strength	9
6.2 Storage	9		
7. Safety Requirements	9		
8. Reliability	10		
9. Appendix A.....	12		

ENGINEERING SPECIFICATION

1. SCOPE

This specification defines the design and performance requirements for high resolution 17 inch professional color monitor. The monitor is capable of displaying IBM VGA, IBM 8514/A, 800x600 graphics proposed by VESA (Video Electronics Standard Association) and 1024 x 768/60/75 Hz, 1280 x 1024, NEC PC-98 and MAC system.

2. INPUT REQUIREMENTS

2.1. A.C. Power Supply

2.1.1. Power Source	100-250 Vac, 50/60 Hz + 6%, -10%
2.1.2. Power Consumption	95 W maximum
2.1.3. AC Line Drop Out	Picture must appear while AC 100 V input drop out (10 ms, 100%)
2.1.4. AC Wave Distortion	10% max. permitted
2.1.5. In-rush Current	< 30 Ao-p at 100 Vac
2.1.6. Power Cord	Detachable, 1.8 meter, 2p with ground type.

2.2. Input Signals

2.2.1. RGB Video	Analogue, 0.0 to 0.7 V peak to peak Separate RGB Input impedance 75 Ohm Positive polarity (Input max. 1.2 V CKT must not be broken down.)
2.2.2. Sync Signal	Separate TTL horizontal & vertical sync Composite TTL Low level 0.8 V maximum High level 2.0 V minimum Composite sync on Green (-0.3 Vp-p) Input impedance greater than 1k Ohm Positive or negative polarity (Dependent on operation mode)
2.2.3. Input Connection	Captive Mini D-sub 15 pin male signal cable Pin 1 Red Pin 9 No Connection Pin 2 Green Pin 10 Ground Pin 3 Blue Pin 11 Ground Pin 4 Ground Pin 12 No Connection Pin 5 Ground Pin 13 H. Sync Pin 6 R Return Pin 14 V. Sync Pin 7 G Return Pin 15 No Connection Pin 8 B Return

ENGINEERING SPECIFICATION

3. ELECTRICAL CHARACTERISTICS

3.1 Picture Tube

3.1.1. Type	17 inch, 90 degree, 29.1 mm neck diameter, Anti-glare, Anti-reflection, Anti-static
3.1.2. Phosphor	Medium short persistence
3.1.3. Dot Pitch	0.28 mm
3.1.4. Light Transmission	52% at screen center

3.2 Switching Power Supply

3.2.1. Type	Non-synchronous power converter
3.2.2. AC Input Range	100-250 Vac, 50/60 Hz + 6%, -10%
3.2.3. Switching Frequency	30 KHz Typical
3.2.4. Protection	No load protection Overload protection Short circuit protection
3.2.5. Efficiency	80% Typical
3.2.6. Degaussing	Automatic during power on and manual at any time

3.3 Video Characteristics

3.3.1. Frequency Response	110 MHz \pm 3 DB
3.3.2. Rise And Fall Time	6 ns maximum
3.3.3. Overshoot And Undershoot	10 % maximum
3.3.4. Video Amplifier Gain	The amplifier gain should be linear within the input video signal amplitude range specified in paragraph 2.2.1.
3.3.5. Black Level Stability	The CRT cathode voltage that corresponds to black on the screen shall not change by more than 10 % of the total cathode voltage (black to white level) when the screen is changed from displaying 10 % full on video (white) to 90 % full on video (white). This holds true for all cathodes.

ENGINEERING SPECIFICATION

3. ELECTRICAL CHARACTERISTICS

3.4 Scanning Characteristics

- | | |
|-------------------------------|--|
| 3.4.1. Horizontal Oscillation | 30 to 65 kHz |
| 3.4.2. Vertical Oscillation | 50 to 110 Hz |
| 3.4.3. Hold In Range | Continuously tracking with sync signal within oscillation range |
| 3.4.4. Preset Modes | Factory preset 12 modes. See Appendix A for detail. User can change the preset models, also can press Recall button to return preset modes. By the way, allocate 15 extra New Timing modes for user |
| 3.4.5. X-ray Protection | Horizontal deflection shut down circuit is equipped to avoid excessive radiation. |
| 3.4.6. User Controls | Brightness, Contrast, Manual degauss, Memory recall, Power switch, Mode switch.
Mode 1: Horizontal position/size, Vertical position/size.
Mode 2: R.G.B. Adjustment, Pincushion
Mode 3: Trapezoid, Pin-Corner, Parallelogram, Rotation. (Press and hold on Mode key switch for 10 ~ 13 sec. to enter Mode 3). |

3.5 Power Saving

- | 3.5.1. Indicator | Green LED / normal power on
Amber LED / power saving active | | | | | | | | | | | | | | | | | | | | |
|----------------------|--|----------|-----------------------------------|---------|-------------------|--------|------------|-----|-----------------------------------|----------|----|-----|----------------------------------|---------|-----|----|-------|-----|----|----|------|
| 3.5.2. Detect | H. V. Sync | | | | | | | | | | | | | | | | | | | | |
| | <table style="width: 100%; border-collapse: collapse;"> <thead> <tr> <th style="text-align: left;">Status</th> <th style="text-align: left;">H</th> <th style="text-align: left;">V</th> <th style="text-align: left;">power consumption</th> </tr> </thead> <tbody> <tr> <td>Normal</td> <td>Yes</td> <td>Yes</td> <td>65W ~ 120W
(depend on H. sync)</td> </tr> <tr> <td>Stand-by</td> <td>No</td> <td>Yes</td> <td>55W ~ 80W
(depend on H. sync)</td> </tr> <tr> <td>Suspend</td> <td>Yes</td> <td>No</td> <td>< 10W</td> </tr> <tr> <td>Off</td> <td>No</td> <td>No</td> <td>< 5W</td> </tr> </tbody> </table> | Status | H | V | power consumption | Normal | Yes | Yes | 65W ~ 120W
(depend on H. sync) | Stand-by | No | Yes | 55W ~ 80W
(depend on H. sync) | Suspend | Yes | No | < 10W | Off | No | No | < 5W |
| Status | H | V | power consumption | | | | | | | | | | | | | | | | | | |
| Normal | Yes | Yes | 65W ~ 120W
(depend on H. sync) | | | | | | | | | | | | | | | | | | |
| Stand-by | No | Yes | 55W ~ 80W
(depend on H. sync) | | | | | | | | | | | | | | | | | | |
| Suspend | Yes | No | < 10W | | | | | | | | | | | | | | | | | | |
| Off | No | No | < 5W | | | | | | | | | | | | | | | | | | |
| 3.5.3 Recover Timing | <table style="width: 100%; border-collapse: collapse;"> <tr> <td style="width: 50%;">Stand-by</td> <td style="width: 50%;">5 ± 2 Sec.</td> </tr> <tr> <td>Suspend</td> <td>5 ± 2 Sec.</td> </tr> <tr> <td>Off</td> <td>8 ± 3 Sec.</td> </tr> </table> | Stand-by | 5 ± 2 Sec. | Suspend | 5 ± 2 Sec. | Off | 8 ± 3 Sec. | | | | | | | | | | | | | | |
| Stand-by | 5 ± 2 Sec. | | | | | | | | | | | | | | | | | | | | |
| Suspend | 5 ± 2 Sec. | | | | | | | | | | | | | | | | | | | | |
| Off | 8 ± 3 Sec. | | | | | | | | | | | | | | | | | | | | |

3.6 Plug & Play

VESA DDC 1/2B Standard

ENGINEERING SPECIFICATION

4. VISUAL CHARACTERISTICS

4.1 Standard Test Condition

4.1.1. Ambient Environment	25 ± 5 °C
4.1.2. Magnetic	CRT shall face East with no additional magnetic field components.
4.1.3. Room Light	400 to 600 Lux diffused ambient
4.1.4. AC Power Input	100 Vac ± 10%, 50/60 Hz + 2%, -4%
4.1.5. Warm-up Time	30 minutes minimum
4.1.6. Luminance	Nominal image intensity is defined as 20 FL at screen center with full white pattern. Raster is set to near cut-off by adjusting external brightness control to maximum.

4.2 Picture Size

4.2.1. For All Presetting Modes	Horizontal width 310± 7 mm Vertical height 232± 5 mm
---------------------------------	---

4.3 Picture Position

4.3.1. Position Control	The position controls shall have enough shift range for preset standard modes
4.3.2. Position Shift	The position shift among all preset modes shall be kept within 7 mm

4.4 Non-linearity

4.4.1. Horizontal	10% for (maxi - mini) / (maxi)
4.4.2. Vertical	7% for (maxi - mini) / (maxi)

4.5 Picture Distortion

4.5.1. Tilt	2.0 mm maximum
4.5.2. Side Pincushion	2.0 mm maximum
4.5.3. Barrel	1.0 mm maximum
4.5.4. Trapezoid Distortion	2.5 mm maximum

4.6 Misconvergence

4.6.1. Zone A (Height Circle)	0.3 mm maximum
4.6.2. Zone B (Elsewhere)	0.4 mm maximum

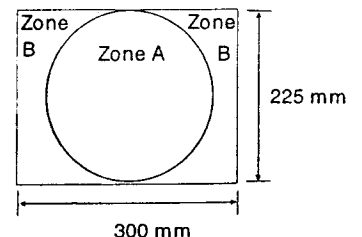

ENGINEERING SPECIFICATION

4. VISUAL CHARACTERISTICS

4.7 Focus

When external contrast is adjusted for $20 \text{ FL} \pm 1 \text{ FL}$ light output with a flat white field pattern, then switched to a character pattern filled with "m" characters, the characters shall be readable and distinguishable.

4.8 Size Stability

4.8.1. Operation Effects The picture size shall not be changed by more than $\pm 1\%$ in any dimension due to the combined effects of input voltage drift, temperature drift, time and high voltage regulation.

4.8.2. User Adjustment Full adjustment of the contrast and brightness controls shall not change the picture size of a fully lit white foreground by more than $\pm 1\%$ in any dimension.

4.9 White Balance

4.9.1. Color Temperature Using the CIE color temperature coordinate system, the color temperature of a full white field shall fall within the following chromaticity coordinates throughout the full brightness and contrast range:
 $X = 0.281 \pm 0.030$
 $Y = 0.311 \pm 0.030$

4.9.2. Color Tracking Measuring a full white field, the color temperature difference at any point on the display picture shall be less than the following (as compared with the center reading) :
 $X = X(\text{center}) \pm 0.020$
 $Y = Y(\text{center}) \pm 0.020$

4.9.3. Color Purity The individual red, green and blue color fields shall maintain a color purity error at any point on the display picture (as compared with the center reading) :
 $X = X(\text{center}) \pm 0.010$
 $Y = Y(\text{center}) \pm 0.010$

4.10 Brightness Uniformity

40% deviation maximum between any two points within the display picture

4.11 Pixel Movement

No more than one dot movement (45 cm from eyes).

ENGINEERING SPECIFICATION

4. VISUAL CHARACTERISTICS

4.12 Gray Scales

0 - 15 gray scales should be linear and present no saturation while turning external user controls.

4.13 Light Output

Bright VR	Contrast VR	Full White	20% Window
Click Center	Max.	25~ 45Ft-L	40~ 60Ft-L
Min.	Min.	\leq 1Ft-L	\leq 1Ft-L
Max.	Min.	\geq 1Ft-L	\geq 1Ft-L
Max.	Max.	25~ 45Ft-L	\geq 60Ft-L

4.14 Light Output VS Time

No more than 10% light output deviation from 10 minutes to 2 hours after power on.

4.15 Thermal Stability

Picture quality variation due to ambient temperature rise from 25 °C to 35°C should be maintained in the following requirements:

- 4.15.1. Phase Shift 2% of horizontal width or less
- 4.15.2. Size Variation 1.5% of picture size or less

4.16 Acoustical Noise

No objectionable noise.

4.17 Turn Off

Set unit at 20 FL of full white picture, then turn off the unit, picture should disappear smoothly. No persistent spot and flash.

4.18 High-Voltage Discharge

The arcing due to monitor high voltage discharge shall not cause any damage to devices connected to the monitor.

ENGINEERING SPECIFICATION

5. MECHANICAL CHARACTERISTICS

5.1 Outlines

5.1.1. Dimensions	418(w) x 417(D) x 438.5(H) mm	W Base
	418(W) x 417(D) x 377(H) mm	W/O Base
5.1.2. Weight	G.W.: 20 kgs	
	N.W.: 17.5 kgs	
5.1.3 Packing Dimensions	555(W) x 565(D) x 517(H) mm	

5.2 Drop Test

Drop Test	High	56 CM
	Sequence	1 Corner
		3 Edge
		6 Face
	Requirements	Electrical function OK
		Mechanical function OK
		No serious damage on set appearance

5.3 Vibration Test

Vibration Test	Condition	Freq: 5-55-5 Hz
		Amplitude: 0.38 m/m peak to peak
		Direction/Time: Forth/back 1hr up/down 1hr
	Requirements	Electrical function OK
		Mechanical function OK
		No serious damage on set appearance

5.4 Cabinet Strength

The application of a weight of 2 kg to any point of cabinet shall not result in a wrong matter with functions or structures.

ENGINEERING SPECIFICATION

6. ENVIRONMENTAL REQUIREMENTS

6.1 Operating

6.1.1. Temperature	0°C to 40°C (No-condensing)
6.1.2. Humidity	20% to 80%
6.1.3. Altitude	10000 feet

6.2 Storage

6.2.1. Temperature	-20°C to 60°C
6.2.2. Humidity	10% to 90%
6.2.3. Altitude	50000 feet

6.3 Dielectric Strength

1500 volts for 1 minutes without breakdown

7. REGULATORY REQUIREMENTS

The basic requirements shall comply with the latest revisions of the followings:

UL	UL 1950
CSA	C22.2 No. 950-M89
FCC	Part 15 Class B
DHHS	CFG-21
TUV/GS	IEC 950 / ZH 1 / 618
BZT	Vfg 243/91

ENGINEERING SPECIFICATION

8. RELIABILITY

8.1 Mean Time Between Failures (MTBF)

MTBF is 30,000 hours (without CRT) minimum. During the operating life, the phosphor will be lit with a duty cycle of 25%. Failures should not occur in either the electronics or CRT. The following defines what constitutes a failure of these two components.

A failure, for the electronics, is defined as any event which changes the characteristics of the electronics in such a way that the monitor no longer meets this specification.

A failure, for a CRT, is defined by one of the following:

1. The inability to display an image on the CRT.
2. The phosphor characteristics have deteriorated to the point where the contrast, brightness or luminance criteria, as defined in this specification, can not be met even though adjustment of service controls.
3. Phosphor burns have occurred, allowing various shapes to be distinguished with either a lit or an unlit raster.

8.2 Mean Time To Repair (MTTR)

The monitor is designed to allow an MTTR of less than 40 minutes to the Field Replaceable Unit (FRU) level.

FRU's are the mainboard, video board and CRT assembly.

8.3 Maintenance And Adjustments

No preventive maintenance or field adjustments shall be required. Service controls should not have to be re-adjusted more frequently than once every 7500 hours of operation to stay within the limits of this specification.

8.4 MTBF Verification Test

A reliability verification test shall be conducted to 80% confidence level on production representative units at the maximum specified operating temperature to assure that the required MTBF has been achieved in the monitor design.

8.5 Ongoing Reliability Test

Ongoing reliability test shall be conducted to 80% confidence level on 30 production units in the first 1000 hours of operation at the maximum operating temperature.

8.6 ESD Immunity(IEC 801-2)

No degradation or loss of function after test on 8kv by air discharge.

ENGINEERING SPECIFICATION

8. RELIABILITY

8.7 CRT Spark

No parts broken after 100 times test

8.8 Line Transient

Continue to operate during the test

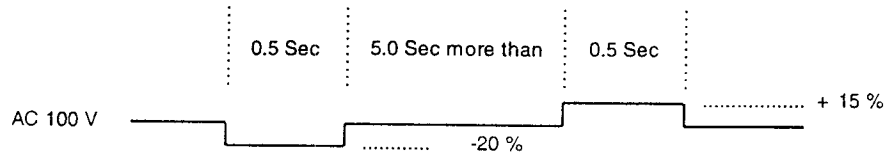

8.9 In-pulse Noise (IEC 801-4)

No degradation or loss of function after the test.

ENGINEERING SPECIFICATION

APPENDIX A. PRESET TIMING

1 of 2

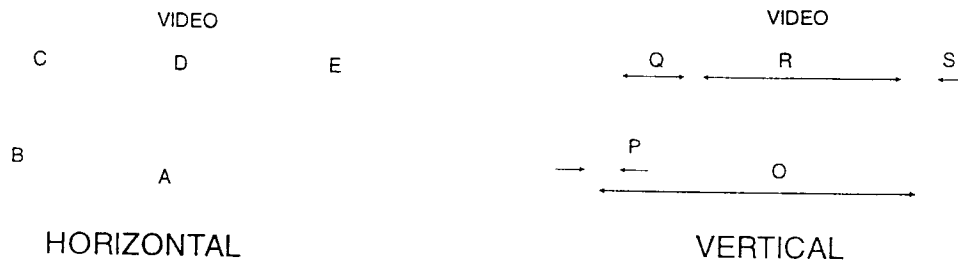

Display Format	VGA			VESA 640 x 480 at 72 Hz	VESA 800 x 600 at 60 Hz
Horizontal Dots	640	720	640	640	800
Vertical Lines	350	400	480	480	600
H. Frequency(kHz)	31.500			37.860	37.879
H. Sync. Polarity	+	—	—	—	+
H. A μ s (Period)	31.780			26.413	26.400
H. B μ s (Pulse Width)	3.810			1.270	3.200
H. C μ s (Back Porch)	1.910			4.603	2.200
H. D μ s (Active Area)	25.420			20.317	20.000
H. E μ s (Front Porch)	0.640			0.762	1.000
V. Frequency(Hz)	70	70	60	72.809	60.317
V. Sync. Polarity	+		—	—	+
V. O ms (Period)	14.270	14.270	16.680	13.735	16.579
V. P ms (Pulse Width)	0.060			0.079	0.106
V. Q ms (Back Porch)	1.910	1.110	1.050	0.740	0.607
V. R ms (Active Area)	11.120	12.710	15.250	12.678	15.840
V. S ms (Front Porch)	1.180	0.380	0.320	0.238	0.026

ENGINEERING SPECIFICATION

APPENDIX A. PRESET TIMING

2 of 2

Display Format	VESA 800 x 600 at 72 Hz	VESA 1024 x 768 at 60 Hz	VESA 1024 x 768 at 70 Hz	VESA 1024 x 768 at 75 Hz	VESA 1280 x 1024 at 60 Hz
Horizontal Dots	800	1024	1024	1024	1280
Vertical Lines	600	768	768	768	1024
H. Frequency(kHz)	48.077	48.363	56.476	60.023	63.981
H. Sync. Polarity	+	—	—	+	+
H. A μ s (Period)	20.800	20.677	17.707	16.660	15.630
H. B μ s (Pulse Width)	2.400	2.092	1.813	1.219	1.037
H. C μ s (Back Porch)	1.280	2.462	1.920	2.235	2.296
H. D μ s (Active Area)	16.000	15.754	13.653	13.003	11.852
H. E μ s (Front Porch)	1.120	0.369	0.320	0.203	0.444
V. Frequency(Hz)	72.188	60.004	70.069	75.029	60.020
V. Sync. Polarity	+	—	—	+	+
V. O ms (Period)	13.853	16.667	14.272	13.328	16.661
V. P ms (Pulse Width)	0.125	0.124	0.106	0.050	0.047
V. Q ms (Back Porch)	0.478	0.600	0.513	0.466	0.594
V. R ms (Active Area)	12.480	15.880	13.599	12.795	16.005
V. S ms (Front Porch)	0.770	0.063	0.053	0.017	0.016

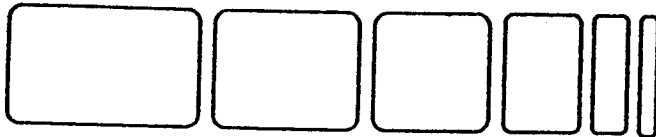

1765D/1785D

ALSO covers 1765GM

TROUBLESHOOTING

1785GM

CTX

+ CPS-1760DF

+ CHUNTEX

1765D

GUIDE

OPUS

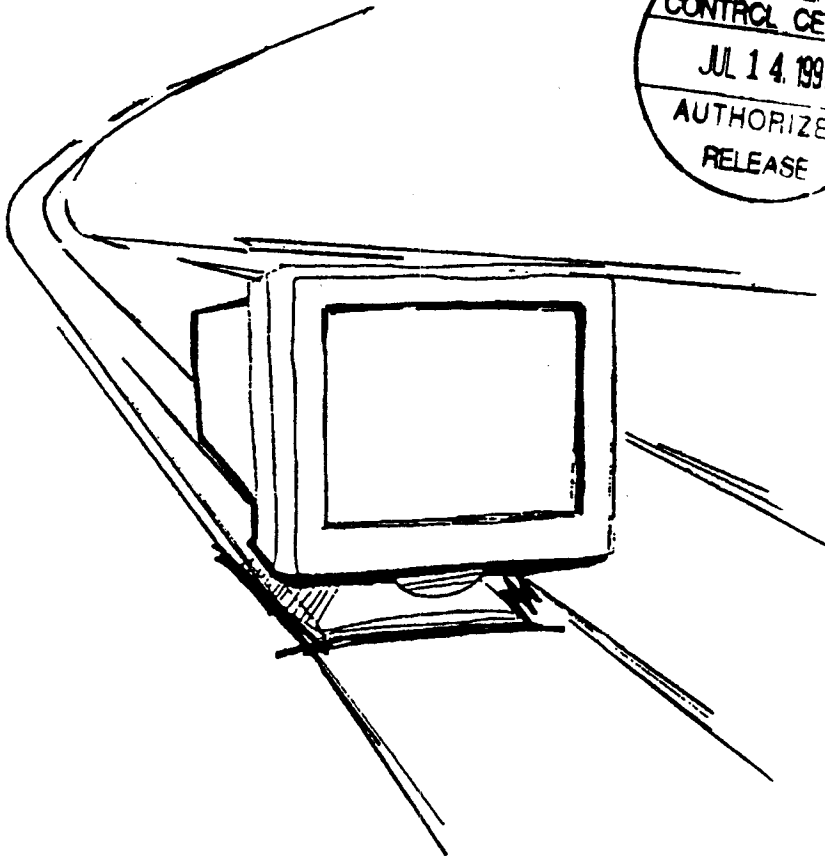
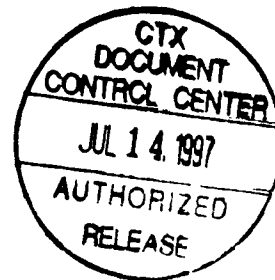

CTX

The Monitor Specialists

EDITION 1
Jan. 1996

1.0 IMPORTANT NOTICE & INTRODUCTION

IMPORTANT NOTICE

Please read before attempting service

1. While the monitor is in operation, do not attempt to connect or disconnect any wires.
2. Make sure the power cord is disconnected before replacing any parts in the monitor.
3. When the power is on, do not attempt to short any portion of the circuit. This shorting may cause damage to the transistors in the monitor.
4. When servicing the H.V. area, be certain that the C.R.T anode is safely discharged before removing the anode cap.
5. Caution must be exercised when servicing this monitor.

INTRODUCTION

Enhanced repair capabilities

This troubleshooting guide is edited for model 1785D/1765D when service is necessary. There are four primary parts included in this troubleshooting guide which offer the easiest way to locate problem points and repair the machine to the best possible condition.

1. The Adjustment section offers the adjustable method, steps and all data of the factory's initial settings which can make the machine get the best performance at that time. By the way, before adjusting, the machine must be warmed up for at least 10 minutes and the CRT face must be in an eastward direction.
2. The Troubleshooting section has four main parts including: power supply, micon circuit, CRT, deflection & video circuit. Each offers fast repair routine and the IC, transistor voltage records against all specified signal modes. These voltage readings are measured with a HP 34401A multimeter with input impedance $10M\Omega$ (0.1V~1000V range) and

waveforms shown on circuit schematics are measured by a Tektronix TDS 520 digital oscilloscope, the monitor receives VGA-480 full white square pattern.

3. The CRT contrast list offers repairmen / technicians the contrast data when CRT replacement is necessary from a different type of CRT.
4. The Spare parts list offers the CTX part number (P/N) which is used frequently by repairmen / technicians. For details please refer to the service guide or service manual. If there is any engineering change regarding this model, CTX will issue the updated information by a non-periodical Technical Bulletin.
5. The transistor voltage records are measured from LEFT side to RIGHT side when face to the front (printed side) of transistor.

3.0 FUNCTION BLOCK DIAGRAM BLOCK

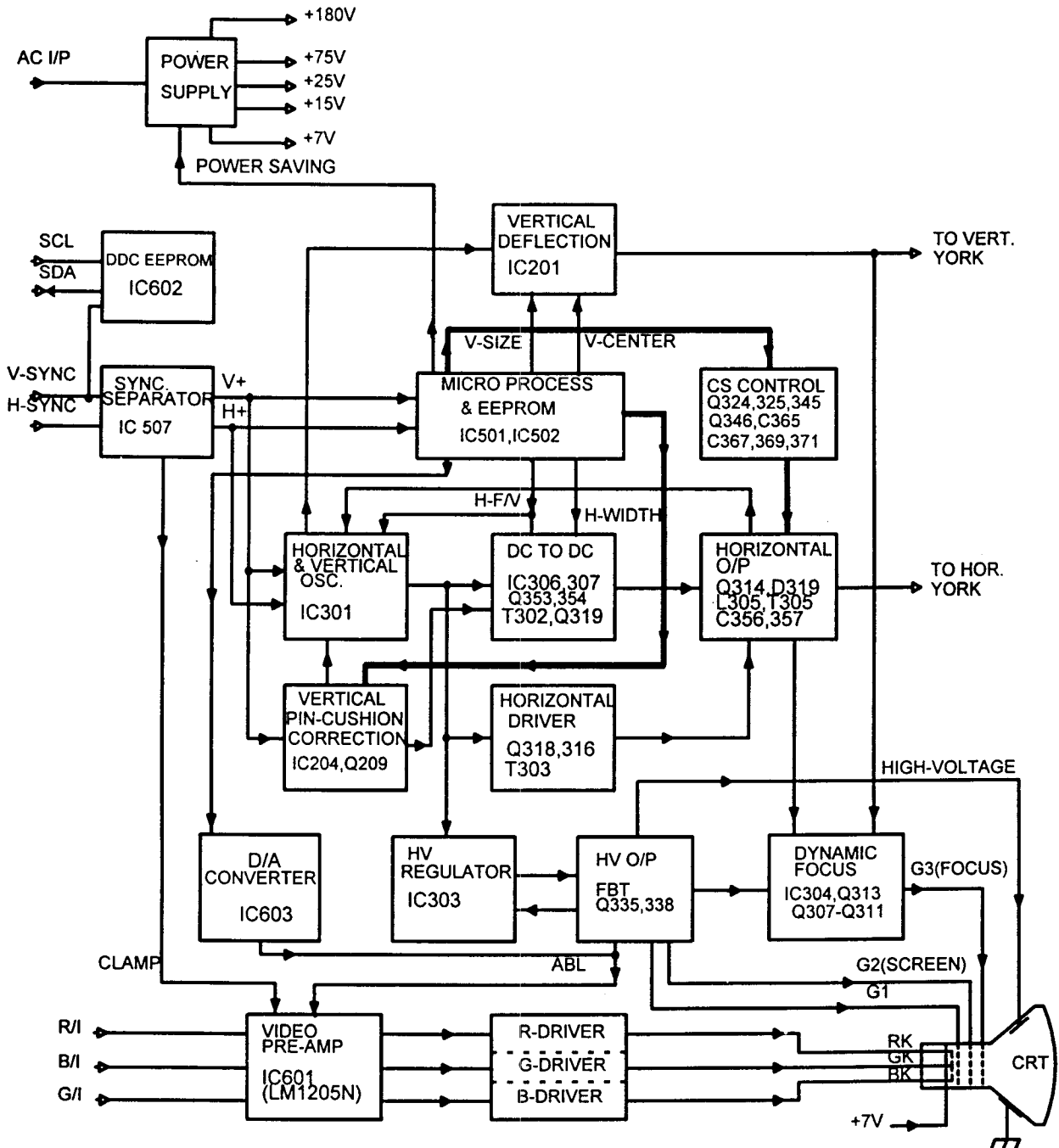

NAME	VESA-480		8514NI		VESA 56K		VESA 60K	
PIXEL RATE	31.5 MHZ		65 MHZ		75 MHZ		78.75 MHZ	
Fh	37.860 KHZ		48.363 KHZ		56.476 KHZ		60.023 KHZ	
Fv	72.809 HZ		60 HZ		70.069 HZ		75.029 HZ	
INTERLACE MODE	NO		NO		NO		NO	
OUTPUT	ANALOG		ANALOG		ANALOG		ANALOG	
FULL SCALE Vpp	1,000		1,000		1,000		1,000	
SYNC ON R/G/B	NO		NO		NO		NO	
CONTROL BITS	0000 0000		0030 0000		0000 0000		0000 0000	
UNIT	PIXEL	ms/us	PIXEL	ms/us	PIXEL	ms/us	PIXEL	ms/us
FRAME BORDER-H	0	0 us	0	0 us	0	0 us	0	0 us
FRAME BORDER-V	0	0 ms	0	0 ms	0	0 ms	0	0 ms
H TOTAL	832	26.413 us	1344	20.677 us	1328	17.707 us	1312	16.66 us
H DISPLAY	640	20.317 us	1024	15.754 us	1024	13.653 us	1024	13.003 us
H REAR PORCH	128	4.063 us	160	2.462 us	144	1.920 us	176	2.235 us
H SYNC WIDTH	40	1.270 us	136	2.092 us	136	1.813 us	96	1.219 us
H SYNC POLARITY	-		-		-		+	
VTOTAL	520	13.735 ms	806	16.667 ms	806	14.272 ms	800	13.328ms
V DISPLAY	480	12.678 ms	768	15.880 ms	768	13.599 ms	768	12.795 ms
V REAR PORCH	28	0.740 ms	29	0.600 ms	29	0.513 ms	28	0.466 ms
V SYNC WIDTH	3	0.079 ms	6	0.124 ms	6	0.106 ms	3	0.05 ms
V SYNC POLARITY	-		-		-		+	
EQUALIZATION ?	NO		NO		NO		NO	
SERRATION ?	NO		NO		NO		NO	
COMP SYNC POLARITY	-		-		-		-	
FIT MODEL	1785D/1765D		1785D/1765D		1785D/1765D		1785D/1765D	

5.0 ADJUSTMENT

5.1 1785D/1765D ADJUSTMENT

REM:PRESET MODE DATA ADJUSTMENT:

- A. Turn off it.
- B. Insert service port .
- C. Turn on it.

ADJUSTMENT	LOCATION	SPECIFICATION/DESCRIPTION	TIMING & PATTERN
75V	VR101	J19=75V \pm 0.5V	31.5KHz X'HATCH
15V	VR308	TP301=15V \pm 0.1V	"
12V	VR310	IC203 BODY=12V \pm 0.2V	"
H.V.	VR401	CRT ANODE=26KV \pm 0.1KV (25KV for 1765D)	"
H-HOLD (L)	VR309	Picture stand or flow shlowly when TP201 shorted to GND.	31KHz ,X'HATCH (NEC24K for Japan)
H-HOLD (H)	VR302	Ditto	64KHz , X'HATCH (56K for 1765D)
FOCUS	1.FOCUS VR1 &VR2 ON FBT. 2.VR304	OPTIMUN	79KHz ,X'HATCH (64K for 1765D)
V-LINE	VR201	$\frac{Y_{max}-Y_{min}}{Y_{max}} \leq 10\%$	VGA-350
V-SIZE	1.EXT SW	MAX	"
	2.VR 202	FULL SCREEN	"
	3.EXT SW	V-SIZE=232mm \pm 7mm	All of PRESET modes X'HATCH
H-CENTER	VR 307	ADJ. RASTER to center	79KHz ,X'HATCH (64KHz for 1765D)
H-PHASE	EXT SW	$\frac{ R-L }{2} \leq 2.5mm$	All of PRESET modes , X'HATCH
V-CENTER	EXT SW	$\frac{ U-D }{2} \leq 2.5mm$	All of PRESET modes , X'HATCH
H-WIDTH	VR306	Just over scan when EXT. H- WIDTH SW. is Max.	MAC 832 , X'HATCH
	EXT SW	H-WIDTH=310 \pm 3mm	All of PRESET modes , X'HATCH
PCC	VR305	Let right side be straight	
HOLD DOWN TEST	P406	P406 short should be hold down	31.5KHz FULL WHITE

Function key of control panel:

Keyboard function Mode	-		+		-		+	
LED dark	H-CENTER		H-WIDTH		V-CENTER		V-SIZE	
LED light	R-GAIN		G-GAIN		B-GAIN		PINCUSHION	
LED flash slowly	KEYSTONE		CORNER		PARALLEL		ROTATION	
LED flash middling	R-BIAS		G-BIAS		B-BIAS		BALANCE	
LED flash fast	CONTRAST		G2		N.C.		N.C.	

6.0 TROUBLESHOOTING

6.1 MAIN TROUBLESHOOTING ROUTINE

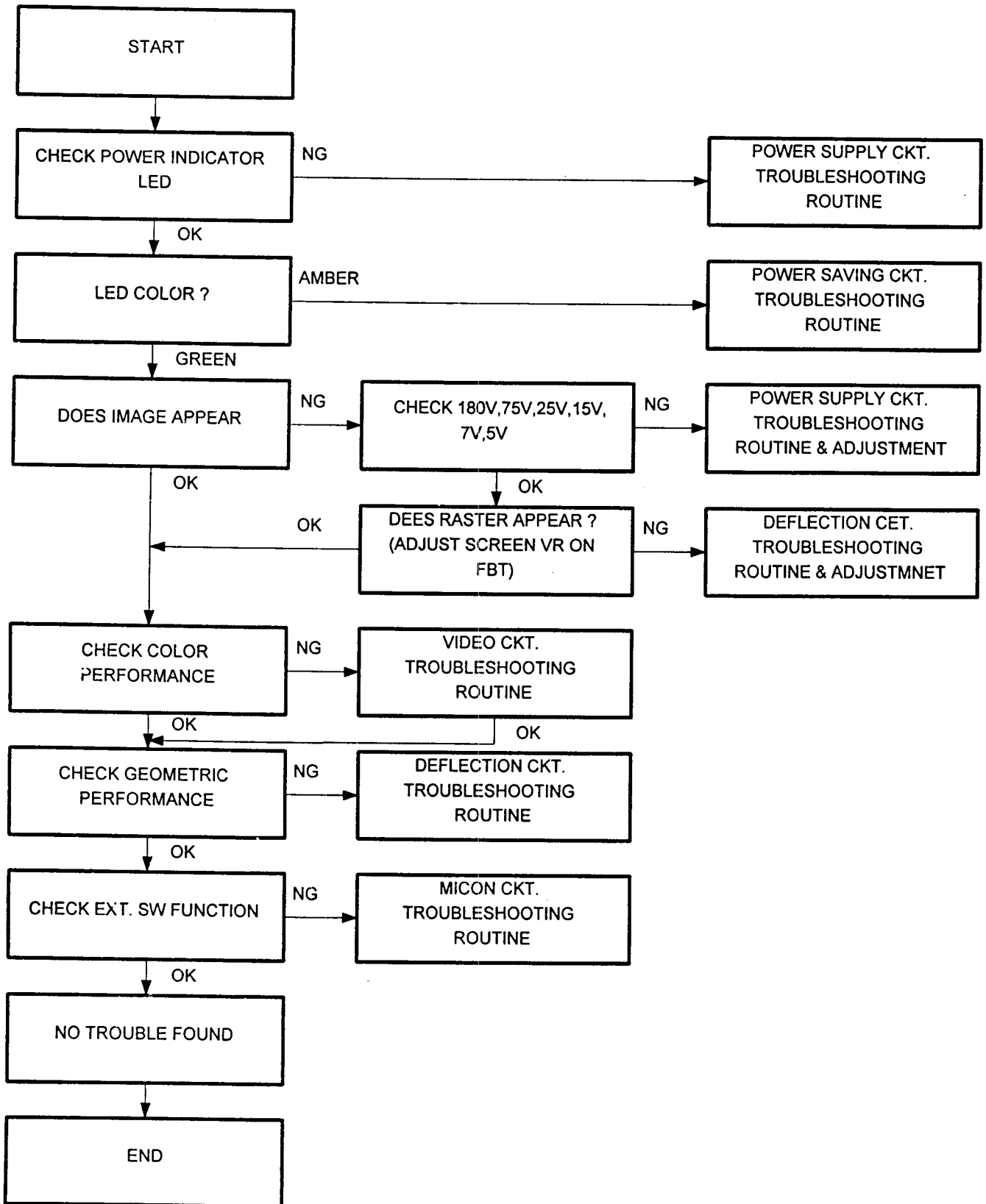

TEST CONDITIONS: TIMING : VGA-480
 PATTERN: CROSS HATCH

Unit: Volt

IC		IC101 (3842)							
AC IN		1	2	3	4	5	6	7	8
MODEL	PIN								
1765D	110V	3.05	2.48	0.09	1.99	0	3.84	15.40	4.98
	220V	2.78	2.48	0.04	1.98	0	1.69	15.37	4.97
1785D	110V	3.161	2.483	0.10	1.96	0	4.10	15.42	4.98
	220V	2.87	2.48	0.05	1.93	0	1.83	15.29	4.98

IC		IC102 (PS2561-M)				IC103 (TL431)		
AC IN		1	2	3	4	R	A	K
MODEL	PIN							
1765D	110V	81.24	79.93	1.92	4.98	70.95	68.65	79.48
	220V	156.22	155.03	2.19	4.97	146.45	144.13	154.66
1785D	110V	82.78	81.75	1.81	4.98	71.52	68.50	80.77
	220V	155.62	154.49	2.10	4.98	145.47	142.88	154.32

TR		SCR101 (BT1690)			Q101 (C945)			Q102 (2SK995)		
AC IN		A	G	K	B	C	E	G	D	S
MODEL	PIN									
1765D	110V	140.92	0	2.14	0.68	0	0	3.80	140.13	0.10
	220V	309.21	0	1.76	0.69	0	0	1.54	310.59	0.04
1785D	110V	143.76	0	2.40	0.68	0.02	0	3.96	143.80	0.10
	220V	303.08	0	1.15	0.67	0	0	1.67	304.40	0.05

TR		Q103 (C945)			Q104 (C945)			Q105 (A733)		
STATUS		B	C	E	B	C	E	B	C	E
MODEL	PIN									
1765D	NORMAL	0.01	1.41	0	0.65	0.01	0	80.96	70.15	82.41
	STAND BY	0.02	1.49	0	0.65	0.02	0	82.06	71.51	74.02
	SUSPAND	0.06	1.61	0	0.61	0.06	0	86.15	86.83	86.68
	OFF	0.06	1.66	0	0.61	0.06	0	87.00	87.60	87.45
1785D	NORMAL	0.02	1.58	0	0.66	0.02	0	83.20	71.75	84.24
	STAND BY	0.01	1.62	0	0.65	0.02	0	82.24	71.87	84.08
	SUSPAND	0.05	1.59	0	0.64	0.05	0	85.33	85.77	85.79
	OFF	0.70	0.01	0	0.42	0.70	0	85.77	86.84	86.84

6.3 MICON CIRCUIT TROUBLESHOOTING ROUTINE

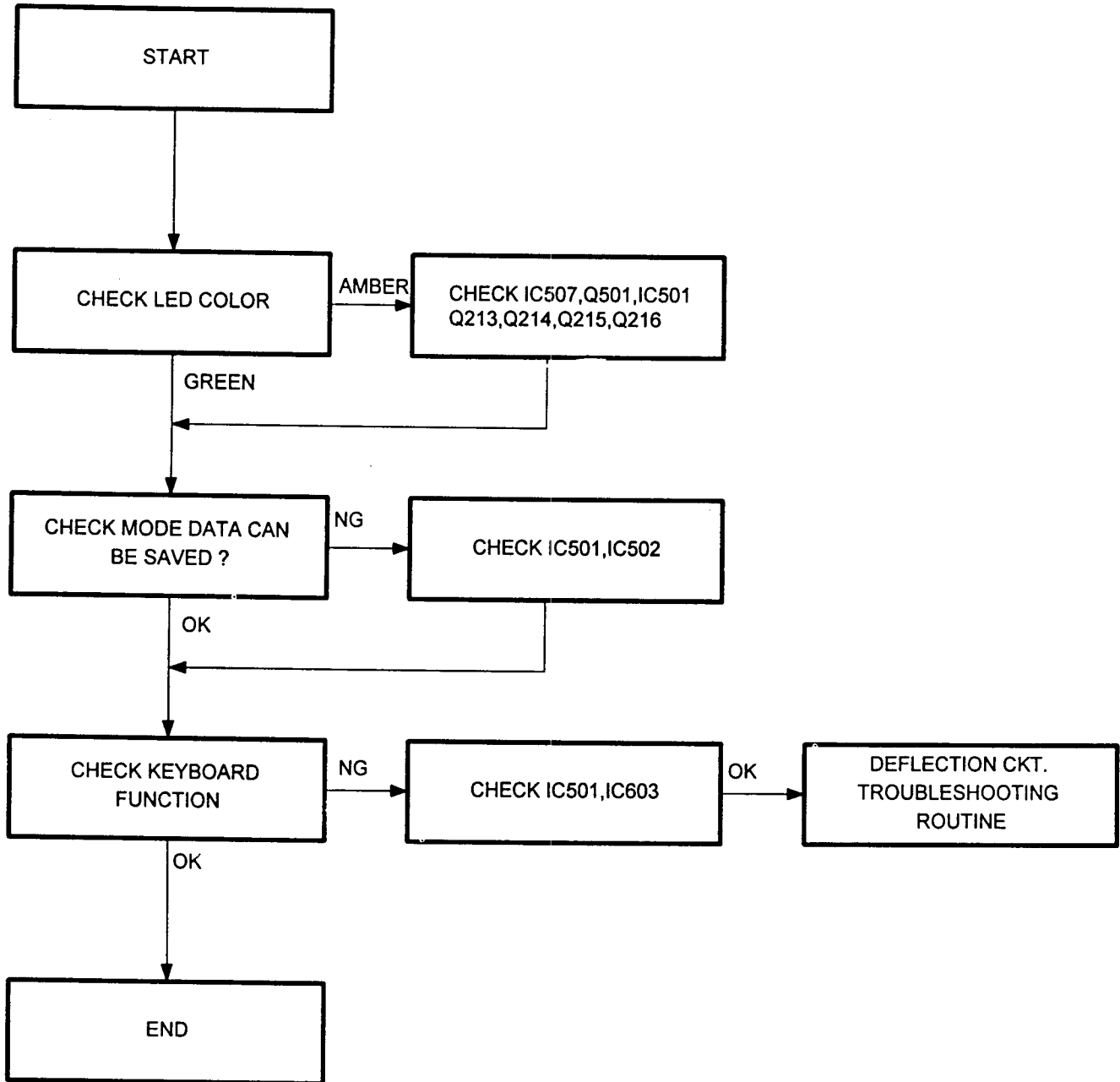

IC		IC502 (24LC04)								
MODE MODEL		PIN	1	2	3	4	5	6	7	8
1765D	VGA 480		0	0	5.00	0	4.99	4.99	0	5.00
	8514NI		0	0	5.00	0	4.99	4.99	0	5.00
	64K		0	0	5.00	0	4.99	4.99	0	5.00
1785D	VGA 480		0	0	5.00	0	4.99	4.99	0	5.00
	VESA 480		0	0	5.00	0	4.99	4.99	0	5.00
	80K		0	0	5.00	0	4.99	4.99	0	5.00

IC		IC504 (XC62A)			IC505 (TL431)			
MODE MODEL		PIN	I	G	O	K	A	R
1765D	VGA 480		6.95	0	5.00	12.34	0	2.50
	8514NI		6.96	0	5.00	12.34	0	2.50
	64K		6.97	0	5.00	12.34	0	2.50
1785D	VGA 480		6.75	GND	5	2.47	GND	12.19
	VESA 480		6.78	GND	5	2.47	GND	12.19
	80K		6.82	GND	5	2.47	GND	12.19

IC		IC507 (M52346)										
MODE MODEL		PIN	1	2	3	4	5	6	7	8	9	10
1765D	VGA 480		5.23	5.23	4.24	4.23	0	6.45	0.78	6.46	3.54	2.46
	8514NI		5.23	5.23	4.23	4.22	0	6.44	0.80	6.45	2.34	2.46
	64K		5.16	5.16	4.23	4.22	0	6.44	11.47	6.45	8.02	2.46
1785D	VGA 480		5.16	5.16	4.19	4.18	0	6.34	0.77	6.36	3.65	2.43
	VESA 480		5.16	5.16	4.19	4.18	0	6.34	0.88	6.36	2.85	2.43
	80K		5.09	5.09	4.17	4.16	0	6.33	11.33	6.35	7.78	2.43

IC		IC507 (M52345)										
MODE MODEL		PIN	11	12	13	14	15	16	17	18	19	20
1765D	VGA 480		0.86	-0.01	0.21	0.77	-0.22	12.34	0.02	5.14	5.01	3.51
	8514NI		0.77	-0.01	0.23	0.68	-0.27	12.34	0.24	5.14	5.01	3.50
	64K		0.69	-0.01	0.20	0.60	-0.28	12.34	0.28	0.03	0.12	3.49
1785D	VGA 480		0.86	0	0.21	0.77	-0.23	12.18	0.22	5.10	5.01	3.48
	VESA 480		0.53	0	0.22	0.43	-0.26	12.18	0.23	5.10	5.01	2.47
	80K		0.70	0	0.20	0.60	-0.29	12.18	0.31	0.03	0.12	3.44

6.4 VIDEO CIRCUIT TROUBLESHOOTING ROUTINE

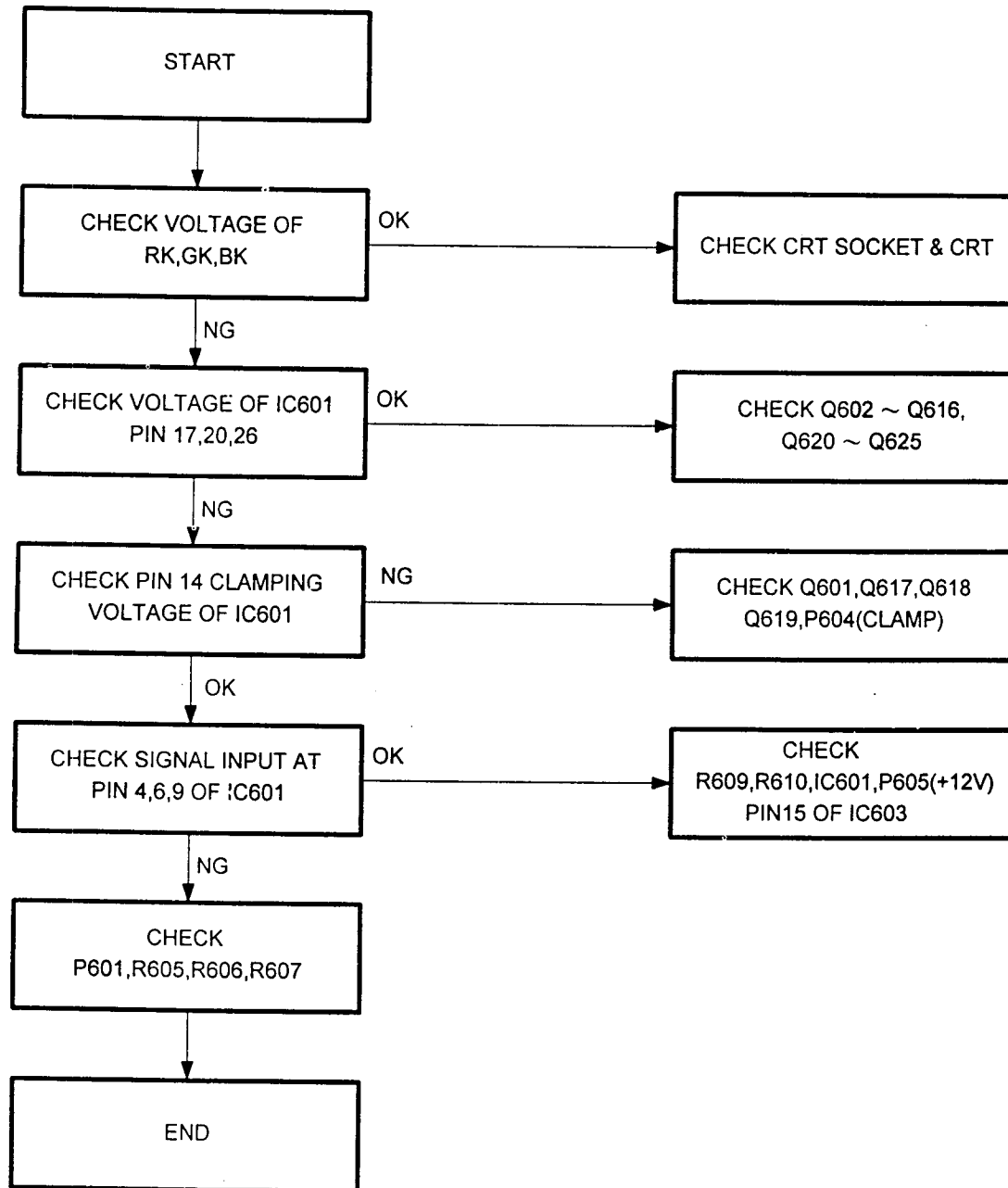

IC		IC603 (TDA8444)								
MODE MODEL		PIN	1	2	3	4	5	6	7	8
1765D	VGA 480		12.04	5.12	4.97	4.97	GND	GND	GND	GND
	8514NI		12.04	5.12	4.97	4.97	GND	GND	GND	GND
	64K		12.04	5.12	4.97	4.97	GND	GND	GND	GND
1785D	VGA 480		12.10	5.19	4.98	4.98	GND	GND	GND	GND
	VESA 480		12.10	5.19	4.98	4.98	GND	GND	GND	GND
	80K		12.10	5.20	4.98	4.98	GND	GND	GND	GND

IC		IC603 (TDA8444)								
MODE MODEL		PIN	9	10	11	12	13	14	15	16
1765D	VGA 480		2.76	0.66	2.78	2.80	2.49	1.13	4.25	1.28
	8514NI		2.76	0.66	2.78	2.78	2.49	1.13	4.09	1.28
	64K		2.76	0.66	2.78	2.80	2.50	1.13	3.85	1.28
1785D	VGA 480		2.97	0.93	3.31	2.80	2.51	4.17	3.34	1.33
	VESA 480		2.97	0.93	3.31	2.84	2.51	4.17	3.26	2.26
	80K		2.97	0.93	3.31	2.84	2.51	4.17	3.51	2.43

TR		Q601 (C945)			Q602 (BFQ232)			Q603 (BFQ252)			
MODE MODEL		PIN	B	C	E	B	C	E	B	C	E
1765D	VGA 480		0	3.87	0	67.38	75.21	66.85	65.90	0	66.37
	8514NI		0	3.81	0	68.24	75.29	67.71	66.78	0	67.19
	64K		0	3.76	0	68.57	75.33	67.97	67.09	0	67.56
1785D	VGA 480		0	3.95	0	65.43	74.99	64.83	64.01	0	64.54
	VESA 480		0	3.93	0	65.67	75.04	65.07	64.22	0	64.71
	80K		0	3.76	0	66.73	75.12	65.73	64.85	0	65.38

TR		Q604 (BFQ262)			Q605 (C945)			Q606 (A733)			
MODE MODEL		PIN	B	C	E	B	C	E	B	C	E
1765D	VGA 480		12.04	65.91	11.35	2.70	12.04	1.99	1.29	11.36	0.60
	8514NI		12.04	66.76	11.36	2.63	12.04	1.93	1.23	11.36	0.54
	64K		12.04	67.09	11.36	2.61	12.04	1.91	1.20	11.36	0.52
1785D	VGA 480		12.09	63.99	11.40	2.82	12.10	2.12	1.42	11.39	0.74
	VESA 480		12.09	64.20	11.39	2.81	12.10	2.11	1.41	11.39	0.73
	80K		12.09	64.86	11.40	2.76	12.10	2.06	1.37	11.40	0.69

TR		Q619 (C945)			Q620 (F484)			Q621 (F483)		
MODEL	PIN MODE	B	C	E	B	C	E	B	C	E
	1765D	VGA 480	0.02	11.74	0	114.18	0	113.11	1.13	114.18
8514NI		0.03	11.59	0	114.17	0	111.98	1.13	114.17	0.57
64K		0.04	11.45	0	114.17	0	111.16	1.13	114.17	0.57
1785D	VGA 480	0.02	11.80	0	95.34	0	95.23	4.16	95.36	3.57
	VESA 480	0.03	11.74	0	95.34	0	95.13	4.16	95.37	3.57
	80K	0.05	11.35	0	95.31	0	93.89	4.16	95.31	3.57

TR		Q622 (F484)			Q623 (F483)			Q624 (F484)		
MODEL	PIN MODE	B	C	E	B	C	E	B	C	E
	1765D	VGA 480	114.18	0	113.11	1.13	114.18	0.57	114.18	0
8514NI		114.17	0	111.98	1.13	114.17	0.57	114.17	0	111.98
64K		114.17	0	111.16	1.13	114.17	0.57	114.17	0	111.16
1785D	VGA 480	95.34	0	95.23	4.16	95.36	3.57	95.34	0	95.23
	VESA 480	95.34	0	95.13	4.16	95.37	3.57	95.34	0	95.13
	80K	95.31	0	93.89	4.16	95.31	3.57	93.89	0	93.89

TR		Q625 (F483)								
MODEL	PIN MODE	B	C	E						
	1765D	VGA 480	1.13	114.18	0.57					
8514NI		1.13	114.17	0.57						
64K		1.13	114.17	0.57						
1785D	VGA 480	4.16	95.36	3.57						
	VESA 480	4.16	95.37	3.57						
	80K	4.16	95.31	3.57						

H-Asynchronous

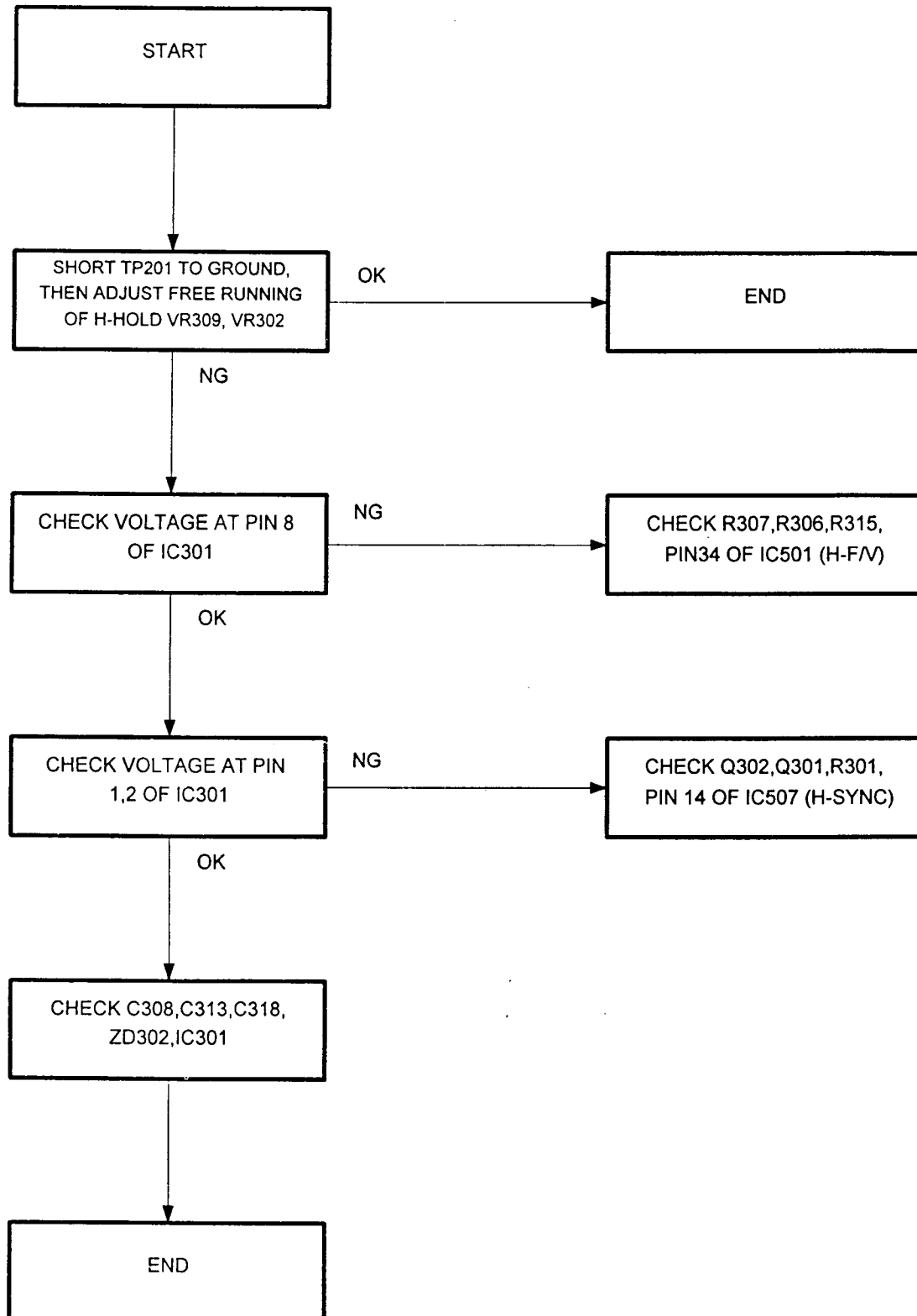

Out of phase

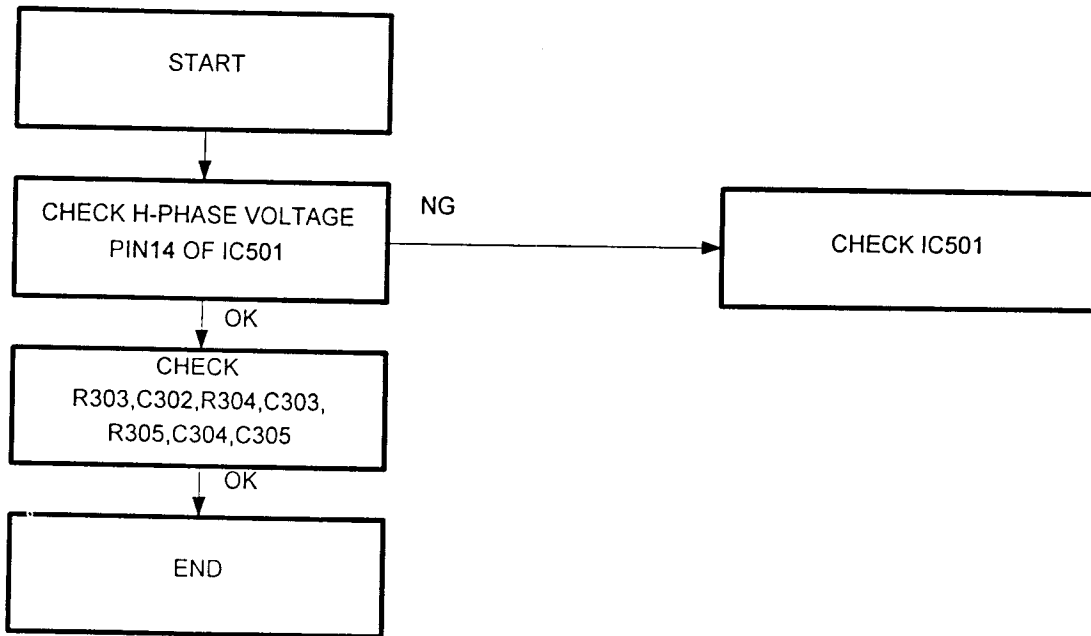

Width Abnormal

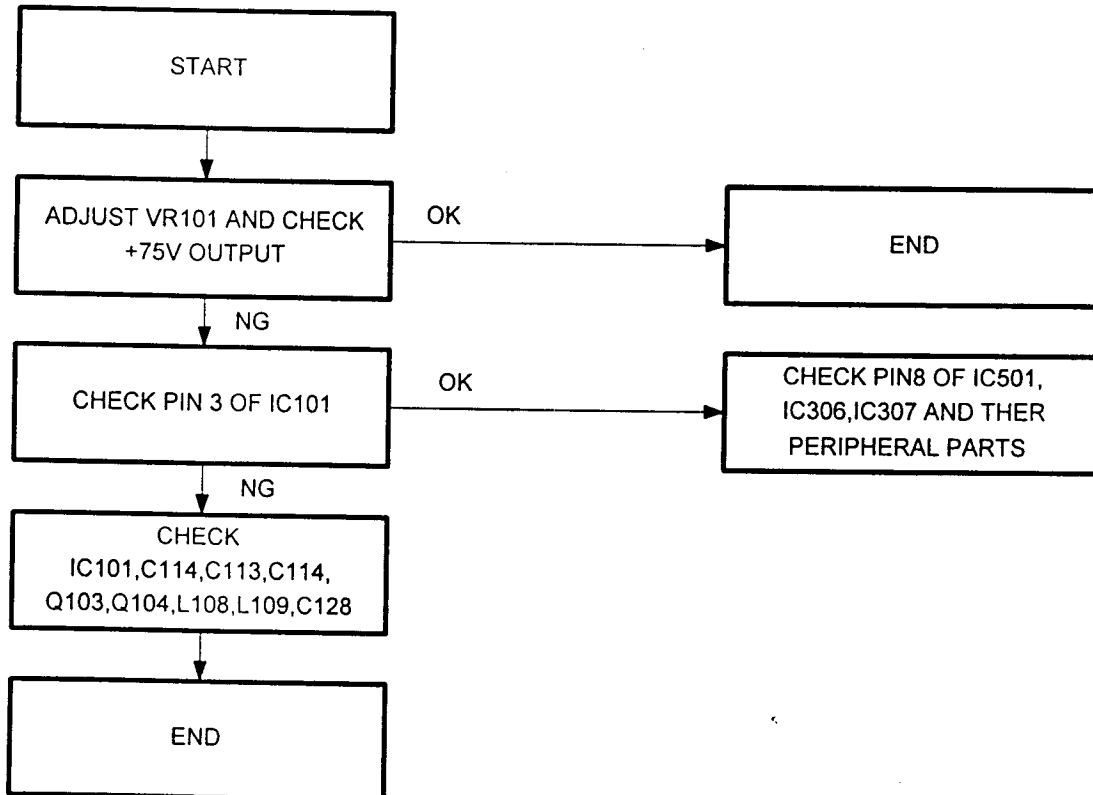

Side pin distortion

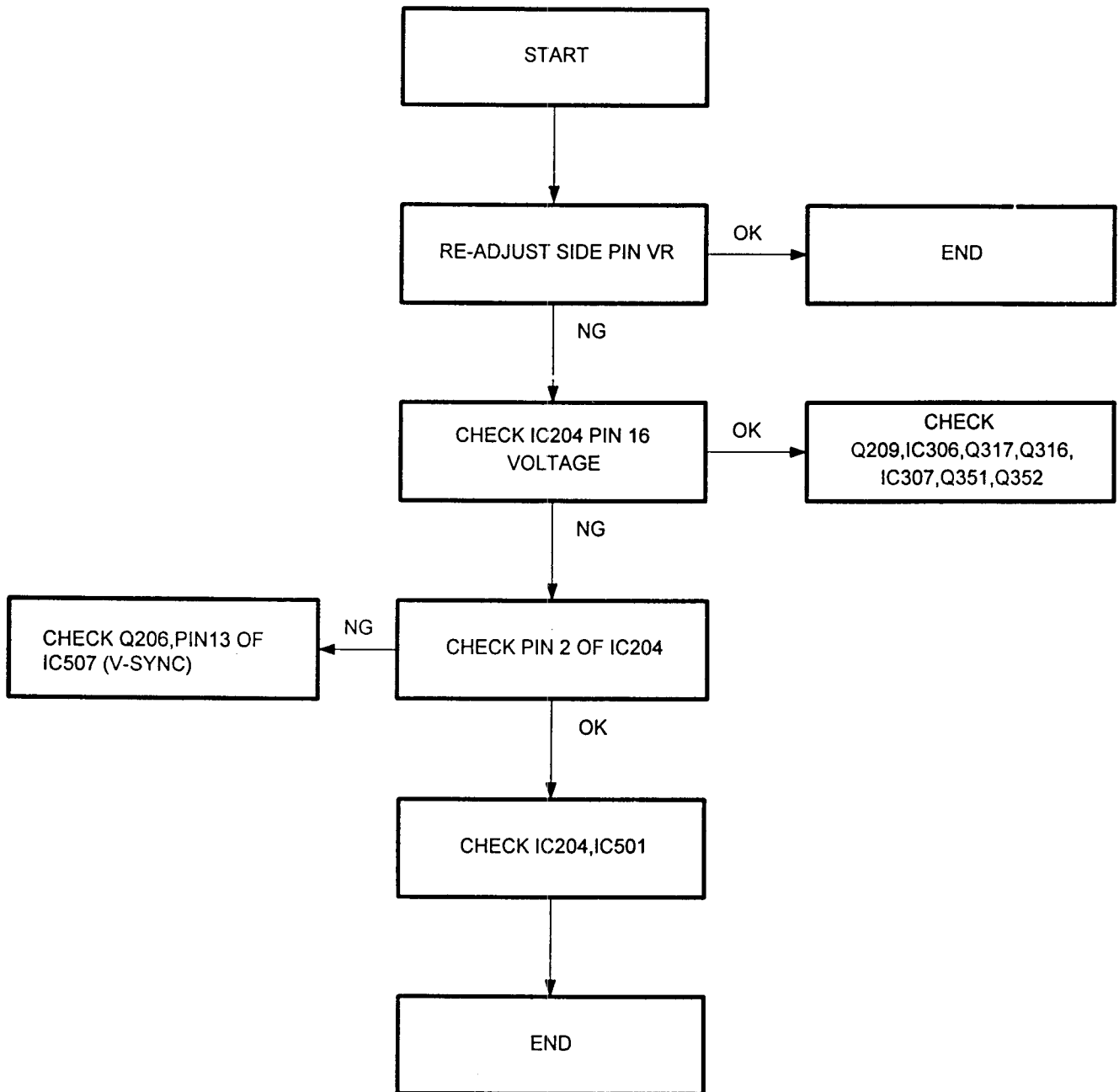

Vertical Size

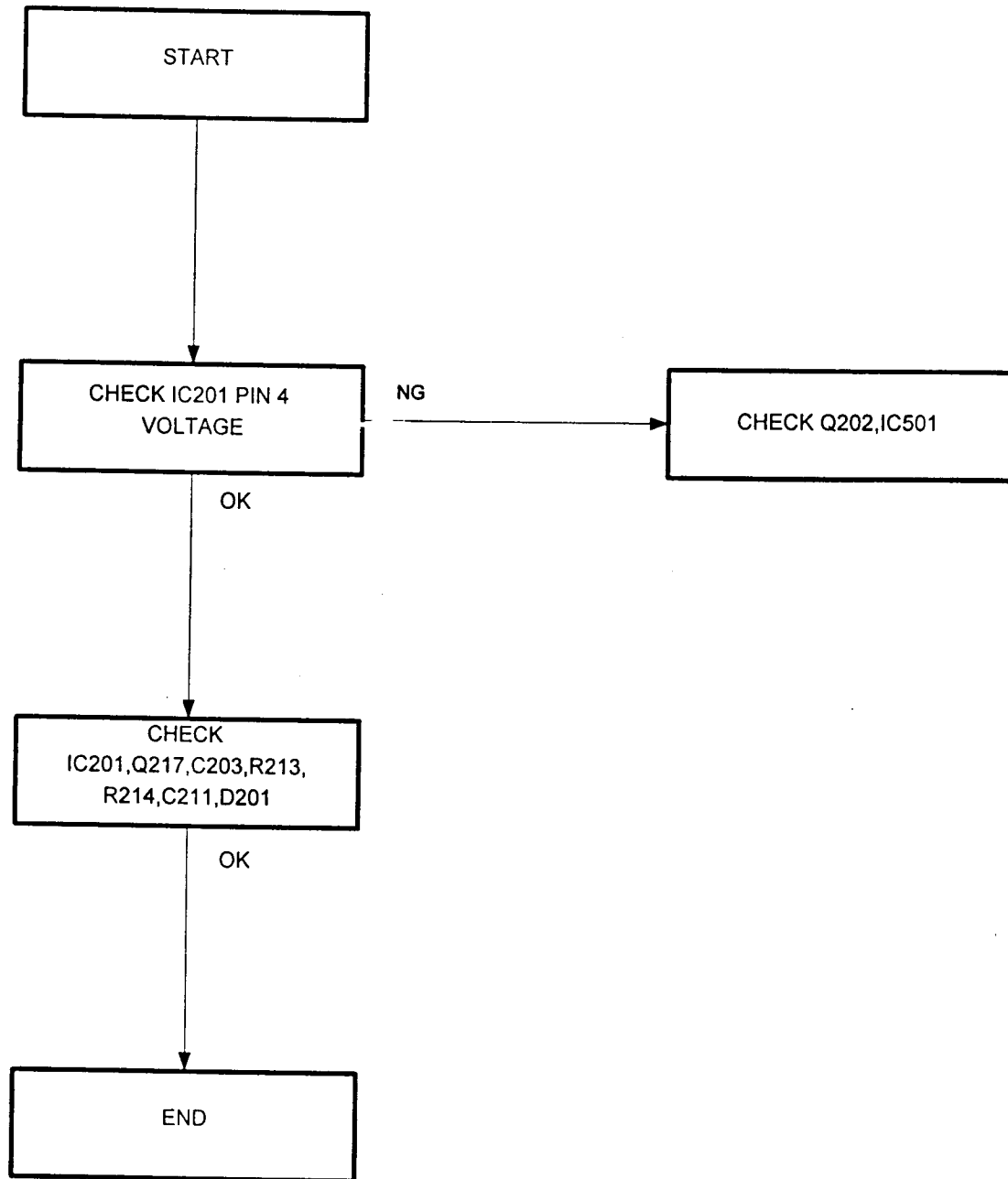

IC		IC301 (LA7860)										
MODE MODEL		PIN	1	2	3	4	5	6	7	8	9	10
1765D	VGA 480		4.74	0.01	1.87	7.21	0	8.25	4.62	0.64	1.58	6.52
	8514NI		4.73	0.01	1.64	7.13	0	8.18	4.64	1.52	2.44	6.52
	64K		4.71	0.01	1.39	7.10	0	8.12	4.65	2.31	3.22	6.50
1785D	VGA 480		4.80	0.01	1.36	7.47	0	8.40	4.57	0.40	1.37	6.60
	VESA 480		4.79	0.01	1.39	7.42	0	8.37	4.57	0.68	1.65	6.63
	80K		4.75	0.01	1.16	7.23	0	8.21	4.60	2.57	3.51	6.57

IC		IC301 (LA7860)										
MODE MODEL		PIN	11	12	13	14	15	16	17	18	19	20
1765D	VGA 480		5.90	0	8.32	9.10	8.31	4.56	0	1.10	4.88	7.09
	8514NI		5.89	0	8.29	9.07	8.31	4.55	0	1.50	4.87	6.83
	64K		5.88	0	8.26	9.05	8.30	4.55	0	1.83	4.86	6.62
1785D	VGA 480		6.01	0	8.48	9.28	8.44	4.62	0.01	1.23	4.95	7.20
	VESA 480		6.01	0	8.47	9.27	8.44	4.61	0.03	1.35	4.94	7.11
	80K		5.98	0	8.45	9.20	8.41	4.57	0.01	2.19	4.90	6.47

IC		IC301 (LA7860)										
MODE MODEL		PIN	21	22	23	24	25	26	27	28	29	30
1765D	VGA 480		11.99	5.24	0	0.08	0.09	0	1.93	6.11	5.74	6.05
	8514NI		11.99	5.26	0	0.08	0.09	0	1.92	6.12	5.74	6.06
	64K		11.98	5.27	0	0.08	0.09	0	1.93	6.14	5.74	6.06
1785D	VGA 480		12.39	5.20	0	0.08	0.10	0	1.86	6.31	6.00	6.24
	VESA 480		12.39	5.20	0	0.09	0.13	0	2.00	6.31	5.73	6.24
	80K		12.37	5.23	0	0.10	0.13	0	2.01	6.30	5.68	6.23

IC		IC303 (3843)								
MODE MODEL		PIN	1	2	3	4	5	6	7	8
1765D	VGA 480		1.75	2.49	0.04	0.40	0	3.16	11.74	5.01
	8514NI		1.63	2.49	0.04	0.38	0	5.16	11.74	5.01
	64K		1.58	2.49	0.05	0.43	0	7.34	11.73	5.01
1785D	VGA 480		1.70	2.49	0.04	0.33	0	2.69	11.90	4.99
	VESA 480		1.65	2.49	0.04	0.29	0	3.28	11.89	4.99
	80K		1.58	2.49	0.05	0.31	0	6.10	11.89	4.99

TR		Q201 (C945)			Q202 (C945)			Q203 (D882)		
MODE MODEL	PIN	B	C	E	B	C	E	B	C	E
	1765D	VGA 480	0.01	4.66	0	2.90	6.00	2.42	11.27	26.49
8514NI		0.01	4.66	0	2.74	6.02	2.28	11.53	26.54	11.48
64K		0.01	4.66	0	2.71	6.04	2.26	12.11	26.58	12.07
1785D	VGA 480	0.02	4.68	0	2.96	6.10	2.47	9.15	26.14	9.12
	VESA 480	0.02	4.66	0	3.48	6.09	2.97	9.52	26.19	9.50
	80K	0.02	4.66	0	3.46	6.09	2.96	10.10	26.29	10.09

TR		Q204 (B772)			Q205 (C945)			Q206 (C945)		
MODE MODEL	PIN	B	C	E	B	C	E	B	C	E
	1765D	VGA 480	10.66	0	11.23	1.35	10.68	0.75	0.21	11.87
8514NI		10.92	0	11.48	1.34	10.95	0.74	0.22	11.87	0.06
64K		11.51	0	12.07	1.31	11.52	0.71	0.20	11.87	0.03
1785D	VGA 480	8.55	0	9.13	1.48	8.57	0.88	0.21	12.03	0.03
	VESA 480	8.92	0	9.51	1.46	8.95	0.85	0.22	12.03	0.04
	80K	9.51	0	10.09	1.42	9.52	0.82	0.20	12.02	0.02

TR		Q208 (C945)			Q209 (C945)			Q210 (C945)		
MODE MODEL	PIN	B	C	E	B	C	E	B	C	E
	1765D	VGA 480	0.01	22.53	-0.01	3.82	11.87	3.25	1.76	8.82
8514NI		0.01	21.53	-0.01	3.94	11.87	3.38	1.76	8.82	1.18
64K		0.01	20.61	-0.01	3.98	11.87	3.41	1.76	8.80	1.18
1785D	VGA 480	0.02	22.43	-0.01	3.79	12.03	3.21	1.77	8.98	1.19
	VESA 480	0.02	22.01	-0.01	3.81	12.03	3.24	1.77	8.96	1.20
	80K	0.02	19.73	-0.01	3.96	12.03	3.39	1.77	8.93	1.21

TR		Q211 (C945)			Q212 (C945)			Q213 (B562)		
MODE MODEL	PIN	B	C	E	B	C	E	B	C	E
	1765D	VGA 480	0.02	10.81	0	0.59	0.02	-0.01	6.39	7.10
8514NI		0.02	10.81	-0.01	0.59	0.02	-0.01	6.39	7.11	7.21
64K		0.02	10.80	-0.01	0.59	0.02	-0.01	6.40	7.12	7.22
1785D	VGA 480	0.01	10.87	0	0.61	0	0	6.11	6.76	7.00
	VESA 480	0.01	10.87	0	0.61	0	0	6.15	6.79	7.03
	80K	0.01	10.87	0	0.61	0	0	6.19	6.82	7.06

TR		Q307 (C945)			Q308 (A733)			Q309 (C945)		
MODE	PIN	B	C	E	B	C	E	B	C	E
1765D	VGA 480	1.46	8.78	0.86	11.68	0.52	12.23	0.52	11.28	0
	8514NI	1.52	8.56	0.92	11.84	0.53	12.45	0.53	11.29	0
	64K	1.58	8.42	0.76	11.93	0.49	12.53	0.49	11.49	0
1785D	VGA 480	2.00	6.81	1.45	13.06	0.56	13.77	0.57	11.57	0.01
	VESA 480	2.01	6.85	1.46	13.03	0.54	13.78	0.55	11.77	0.01
	80K	1.97	6.96	1.42	13.02	0.43	13.67	0.43	12.26	0.02

TR		Q310 (C4632)			Q311 (C4632)			Q313 (C945)		
MODE	PIN	B	C	E	B	C	E	B	C	E
1765D	VGA 480	11.88	391.58	11.28	391.74	839.79	393.81	1.52	8.69	0.97
	8514NI	11.88	375.35	11.29	375.02	840.26	399.62	1.52	8.69	0.97
	64K	11.88	361.06	11.28	361.25	840.61	404.98	1.59	8.57	1.01
1785D	VGA 480	12.04	355.07	11.59	354.27	799.48	425.98	2.00	6.92	1.34
	VESA 480	12.04	351.07	11.80	350.63	800.00	421.24	2.01	6.70	1.34
	80K	12.04	340.93	12.16	334.04	799.71	393.49	1.95	5.92	1.12

TR		Q314 (C4924)			Q316 (C945)			Q317 (A733)		
MODE	PIN	B	C	E	B	C	E	B	C	E
1765D	VGA 480	-0.73	55.95	0	13.73	26.52	13.12	13.12	0	10.85
	8514NI	-0.73	88.16	0	13.72	26.52	13.11	13.11	0	10.87
	64K	-0.74	116.11	0	13.77	26.47	13.16	13.16	0	10.64
1785D	VGA 480	-0.51	48.88	0	13.69	26.12	13.08	13.08	0	10.58
	VESA 480	-0.50	60.20	0	13.68	26.17	13.07	13.08	0	10.78
	80K	-0.50	126.66	0	13.22	26.27	12.63	12.63	0	10.34

TR		Q318 (K357)			Q319 (K1377)			Q320 (C945)		
MODE	PIN	G	D	S	G	D	S	B	C	E
1765D	VGA 480	4.33	16.93	-0.01	62.77	179.42	58.87	0.54	-0.04	0
	8514NI	4.33	18.96	-0.01	97.73	179.42	92.43	0.51	-0.07	0
	64K	4.43	19.65	-0.01	127.20	179.60	120.67	0.49	-0.09	0
1785D	VGA 480	4.19	16.41	0	55.38	178.85	51.88	0	15.20	0
	VESA 480	4.20	16.14	0	67.90	178.82	63.87	0.53	-0.04	0
	80K	4.29	14.44	0	137.41	178.76	130.65	0.51	-0.08	0

TR		Q339 (C945)			Q340 (C945)			Q341 (C945)		
MODEL	MODE PIN	B	C	E	B	C	E	B	C	E
	1765D	VGA 480	-0.11	22.55	-0.01	0.07	25.32	0	22.54	26.55
8514NI		-0.16	21.54	-0.01	0.07	25.37	0	21.54	26.60	21.22
64K		-0.19	20.62	-0.01	0.07	25.40	0	20.62	26.62	20.33
1785D	VGA 480	-0.10	22.43	-0.01	0.07	24.89	0	22.43	26.19	22.09
	VESA 480	-0.12	22.02	-0.01	0.07	24.94	0	22.02	26.24	21.69
	80K	-0.22	19.74	-0.01	0.07	25.03	0	19.74	26.34	19.48

TR		Q342 (A733)			Q344 (A733)			Q345 (IRF630)		
MODEL	MODE PIN	B	C	E	B	C	E	G	D	S
	1765D	VGA 480	22.54	-0.01	22.19	11.79	-0.01	11.88	-0.03	20.23
8514NI		21.54	-0.01	21.22	11.80	-0.01	11.88	-0.06	36.95	-0.01
64K		20.62	-0.01	20.33	11.81	-0.01	11.88	-0.09	45.04	-0.01
1785D	VGA 480	22.43	-0.01	22.09	11.94	-0.01	12.04	15.18	0	0
	VESA 480	22.02	-0.01	21.69	11.95	-0.01	12.04	15.15	0	0
	80K	19.74	-0.01	19.49	11.95	-0.01	12.04	-0.08	50.48	0

TR		Q346 (IRF630)			Q350 (C945)			Q351 (A733)		
MODEL	MODE PIN	G	D	S	B	C	E	B	C	E
	1765D	VGA 480	-0.03	19.78	-0.01	-0.01	3.06	-0.01	19.53	11.23
8514NI		-0.06	36.44	-0.01	-0.01	2.98	-0.01	19.58	9.34	20.20
64K		-0.09	44.56	-0.01	-0.01	2.78	-0.01	19.61	7.72	20.22
1785D	VGA 480	15.18	0	0	-0.01	2.36	-0.01	19.21	11.57	19.82
	VESA 480	-0.04	20.35	0	-0.01	2.16	-0.01	19.26	10.95	19.87
	80K	-0.08	50.17	0	-0.01	2.39	-0.01	19.36	6.79	19.97

TR		Q352 (C945)			Q353 (C945)			Q354 (A733)		
MODEL	MODE PIN	B	C	E	B	C	E	B	C	E
	1765D	VGA 480	-0.03	11.23	0	8.30	26.47	8.66	8.31	0
8514NI		-0.05	9.36	0	12.95	26.52	13.41	12.94	0	13.41
64K		-0.06	7.73	0	16.82	26.55	17.25	16.79	0	17.25
1785D	VGA 480	-0.01	11.57	0	7.23	26.12	7.62	7.25	0	7.62
	VESA 480	-0.01	10.95	0	8.87	26.17	9.31	8.88	0	9.31
	80K	-0.02	6.80	0	17.97	26.27	18.49	17.96	0	18.49

7.0 IC CONFIGURATION

(1) 3842,3843
(IC101,IC303)

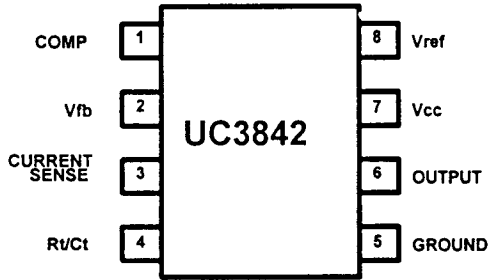

(2) 2561 (IC102)

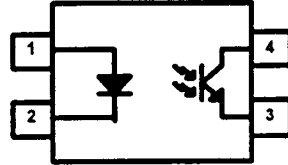

(3) LA7838 (IC201)

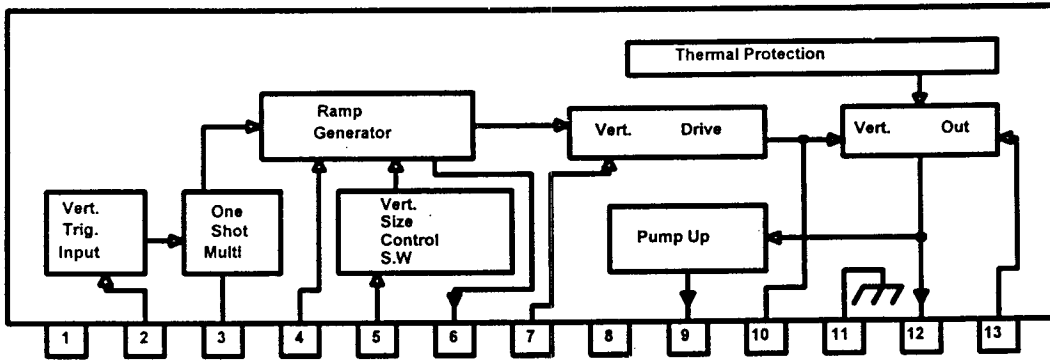

(4) AN614 (IC202)

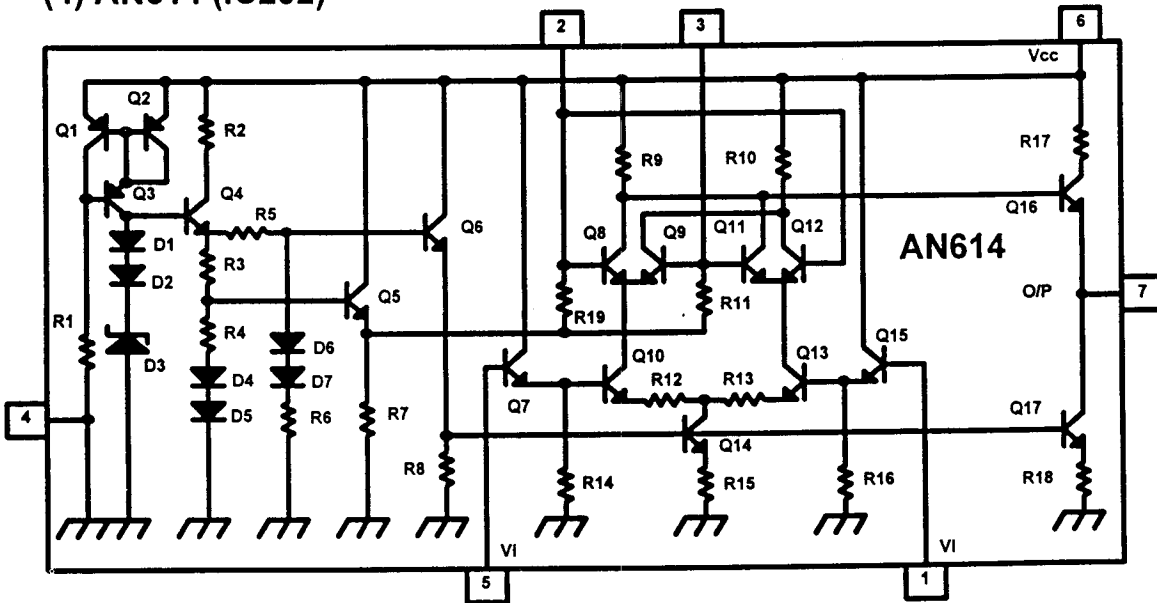

(9) M52346SP (IC507)

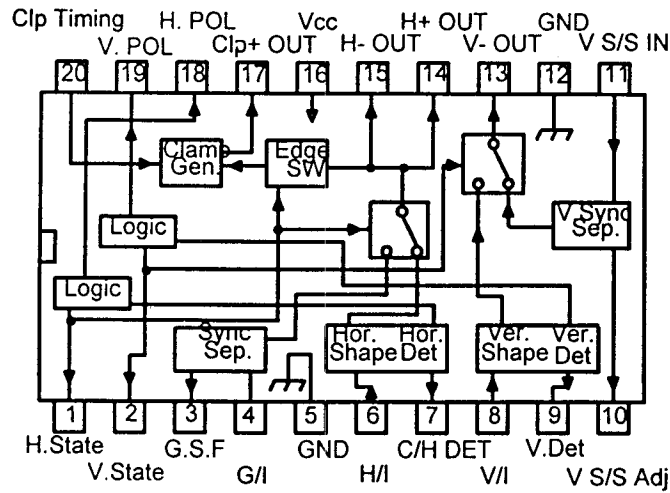

(10) TDA8444 (IC603)

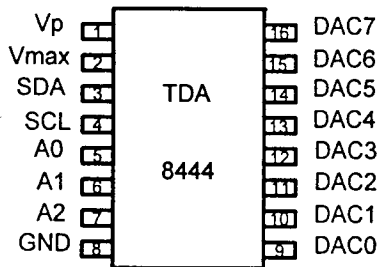

(11) 24LC21 (IC602)

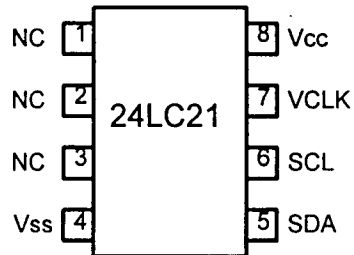

8.0 LAYOUT FOR MAIN COMPONENTS AND ADJUSTED

9.0 CIRCUIT DIAGRAM

MAIN BOARD REV. B					
ITEM	PART NO.	DESCRIPTION	LOCATION	CLASSIFICATION	REMARK
33	14C3P-150C	2SC4924	Q314	●	
34	14K22-080P	2SK357	Q318		
35	14B17-010P	2SB649	Q323		
36	14K22-110W	IRF630	Q324,Q325	●	
37	14C3P-080C	2SC4769	Q335	●	
38	14D17-010P	2SD669	Q336		
39	14K22-210A	2SK1377	Q338,Q319		
40	14C92-101B	2SC2001	Q348		
41	47S00-0670	X'FMR	T101	N	
42	47D10-0151	X'FMR	T302		
43	47F13-0470	FBT	T402	N	For 1765 STD.
	47F13-0530	FBT	T402	N	For 1765D CE MARK
	47F13-0490	FBT	T402	N	For 1785 STD.
	47F13-0550	FBT	T402	N	For 1785D CE MARK

VIDEO BOARD REV. B					
ITEM	PART NO.	DESCRIPTION	LOCATION	CLASSIFICATION	REMARK
1	17A04-090H	VIDEO IC LM1205N	IC601	●	
2	16M08-007R	24LC21	IC602		
3	17A23-004H	TDA8444	IC603	⊙,N	
4	14C26-170E	BFQ232	Q602		
5	14C26-180E	BFQ252	Q603		
6	14C26-110E	BFQ262	Q604	●	
7	14C92-281P	2SC1906	Q605		
8	14C26-120P	BFQ162	Q606	●	
9	14C92-111B	2SC945	Q617		
10	14A92-021B	2SA733	Q618		
11	14A92-141E	BF488	Q620		
12	14C92-201E	BF483	Q621		
13	23765-2715	270Ω 3W	R622	⊙	

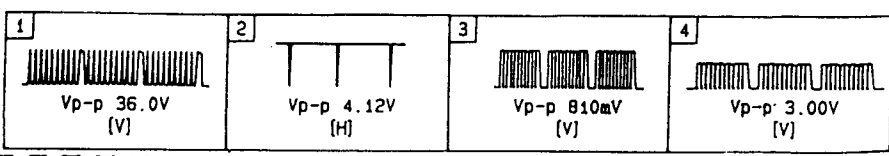
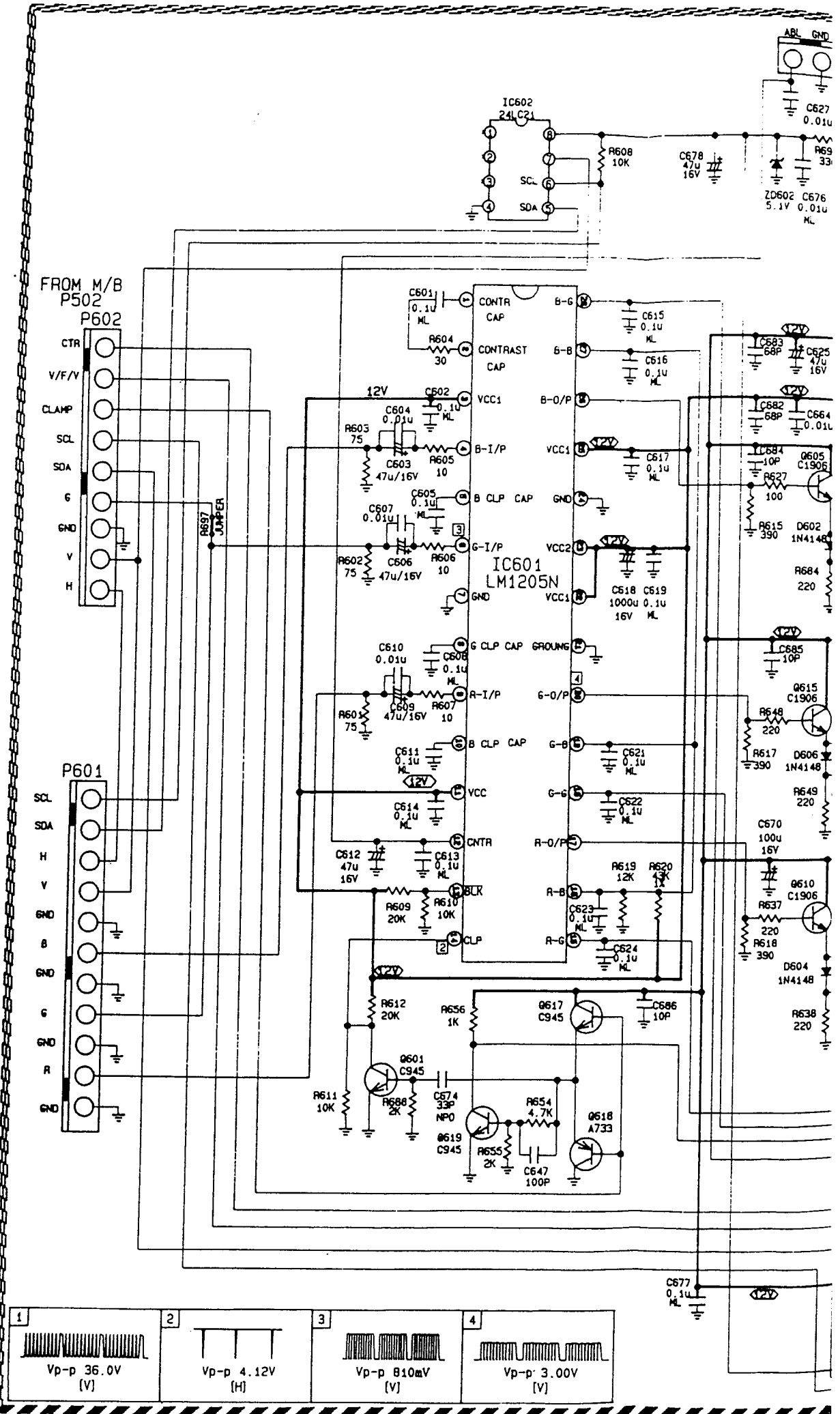

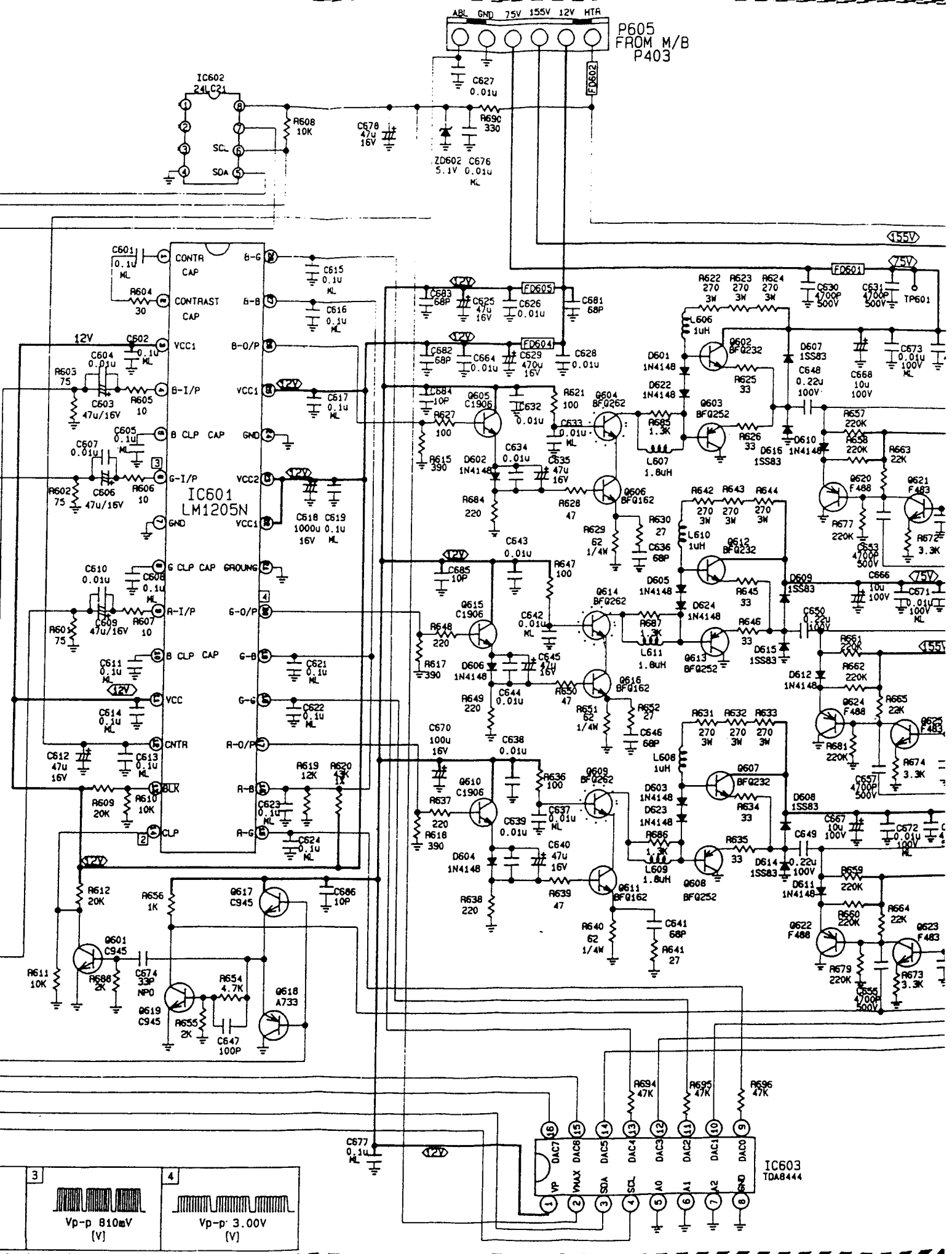

ABL GND 75V 155V 12V HTR
 P605 FROM M/B P403

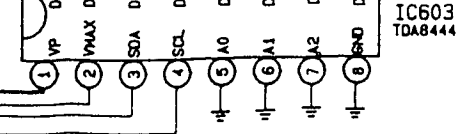
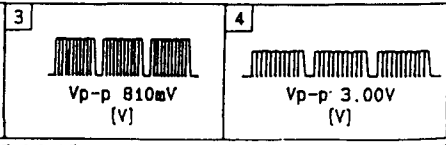
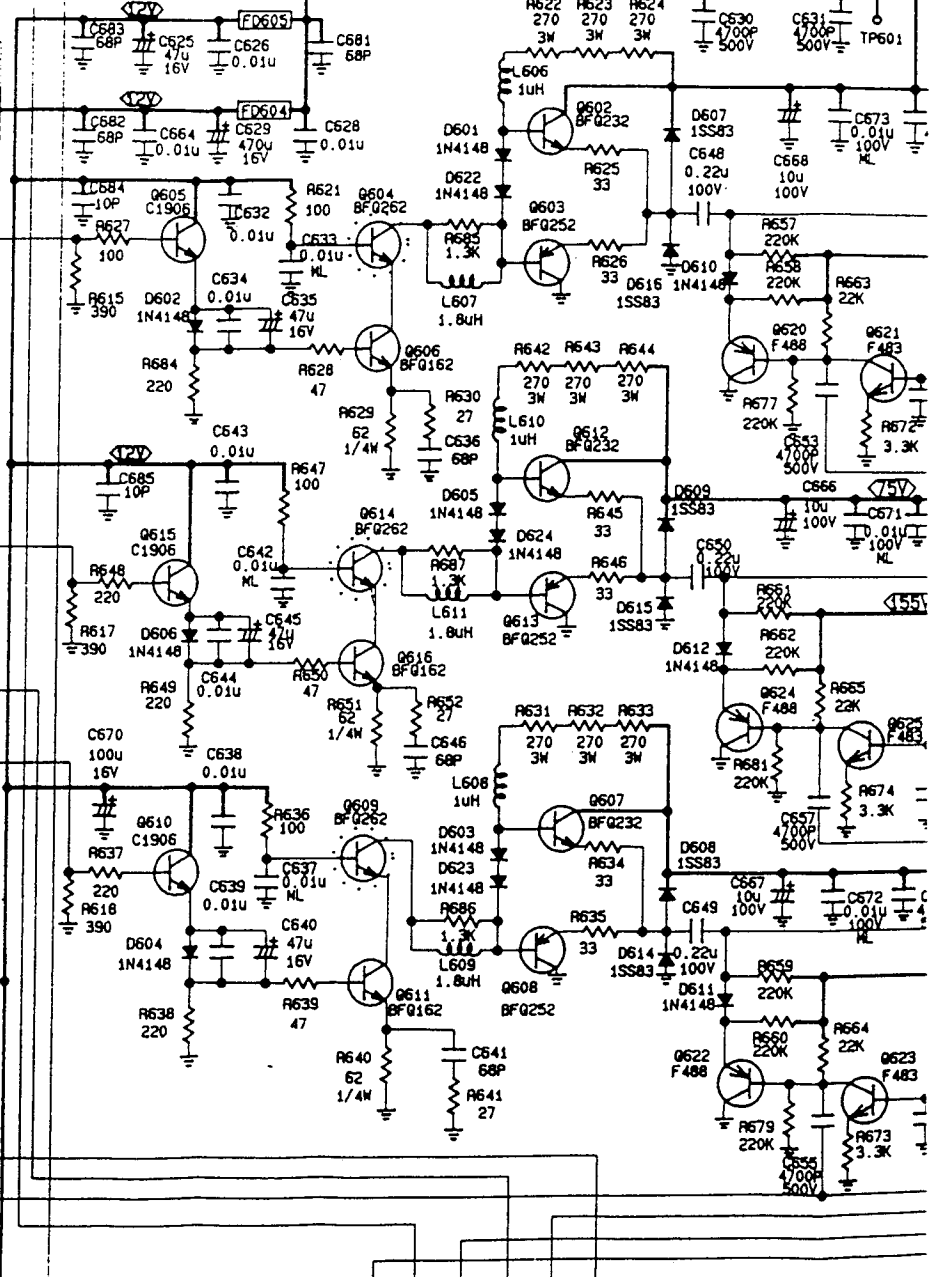
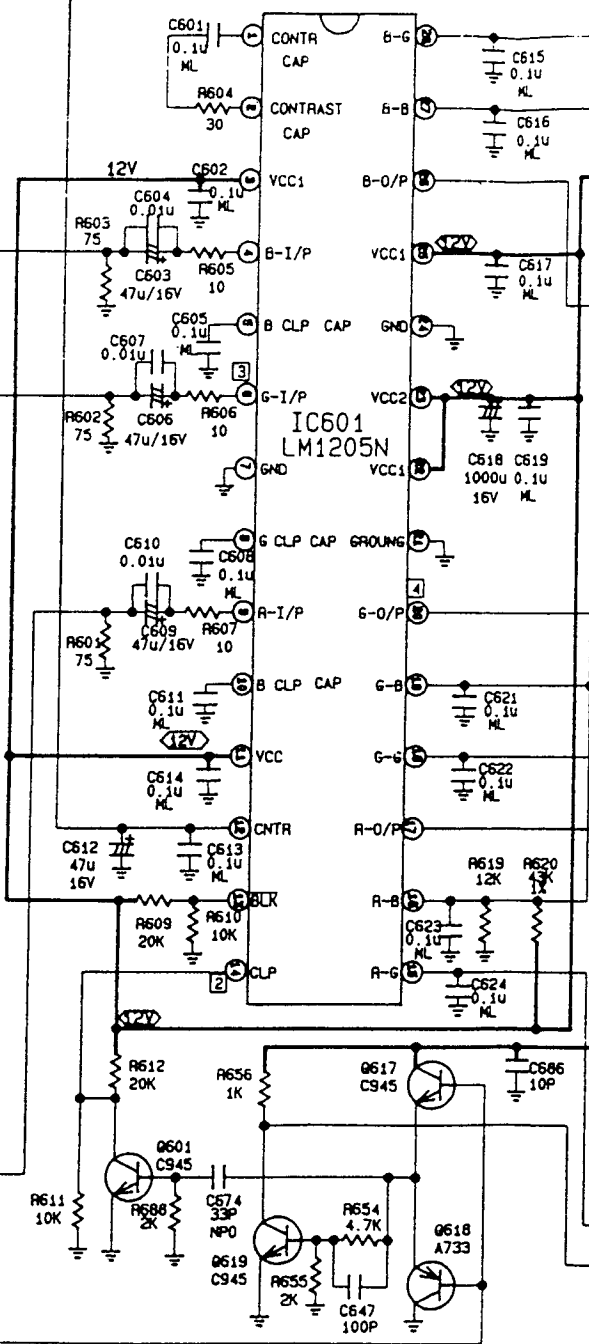
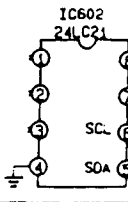

75V 155V 12V HTR

P605
FROM M/B
P403

1785D	
HITACHI	
R675	0.68/1W

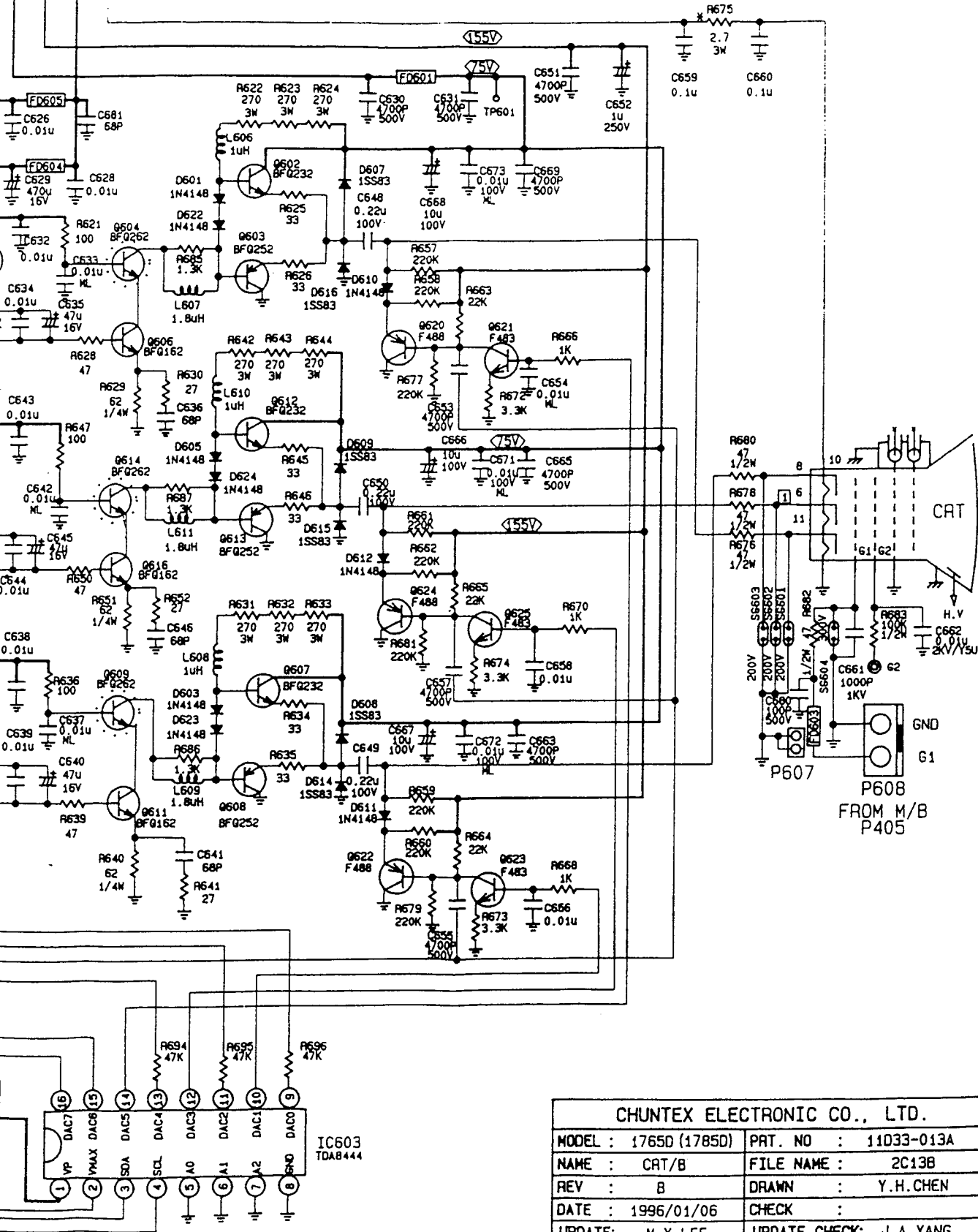

CHUNTEX ELECTRONIC CO., LTD.	
MODEL : 1765D (1785D)	PRT. NO : 11033-013A
NAME : CRT/B	FILE NAME : 2C13B
REV : B	DRAWN : Y.H.CHEN
DATE : 1996/01/06	CHECK :
UPDATE: M.Y.LEE	UPDATE CHECK: J.A.YANG

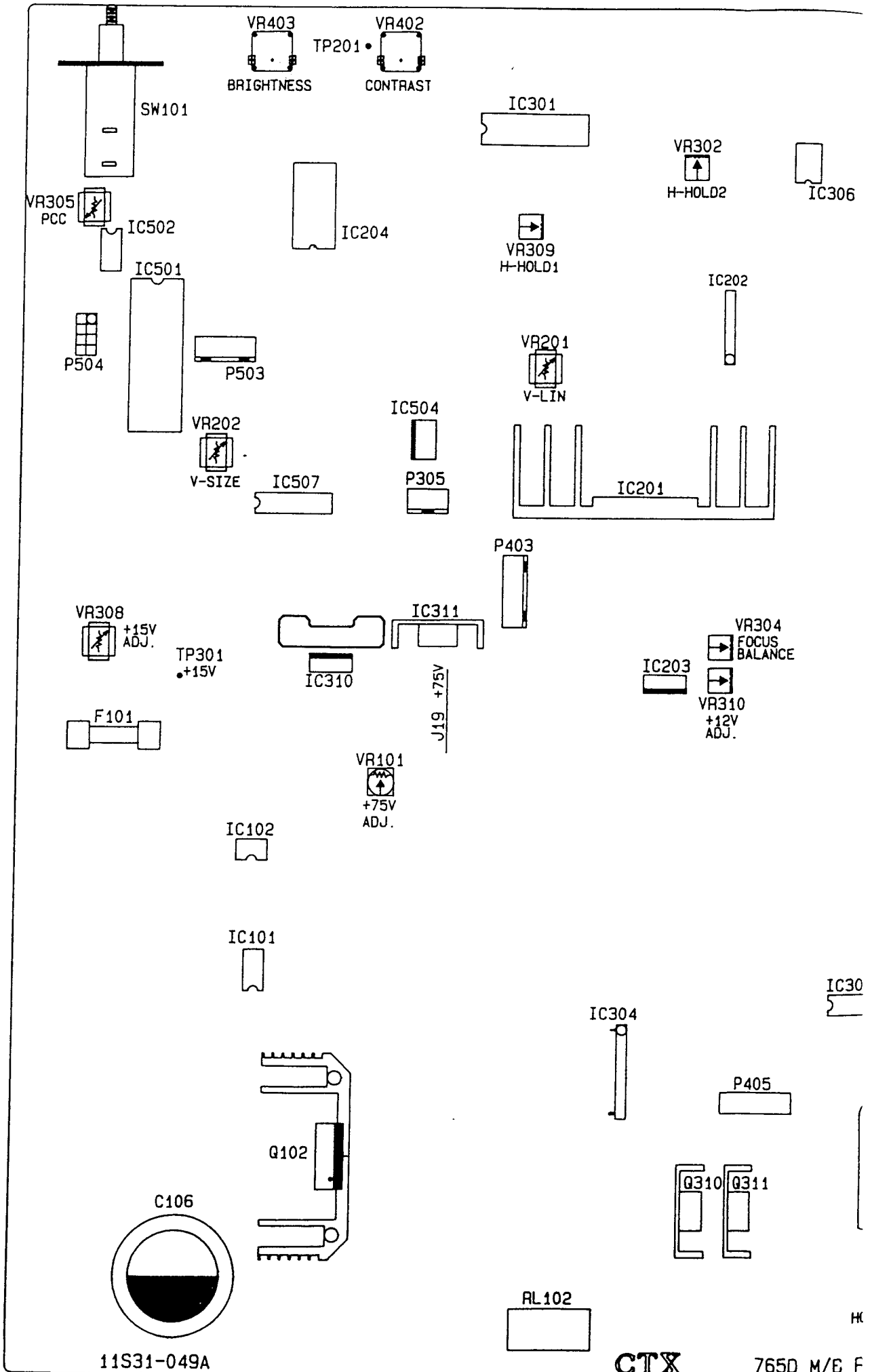

11S31-049A

CTX

765D M/E F

MAIN/B

CR

CTX
REV: A1
765D CRT. BD. 11033-013A

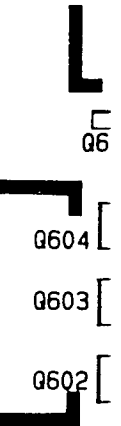

CR01

DISP

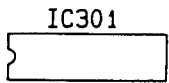
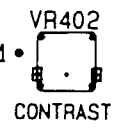

C204

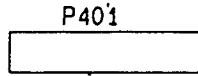
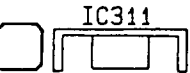
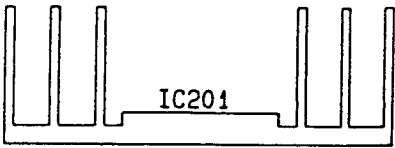
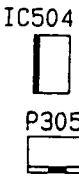

J19 +75V

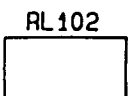
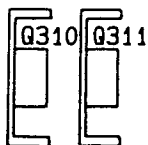
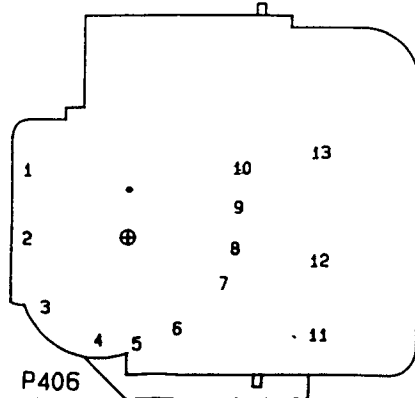
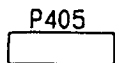
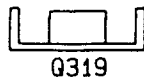
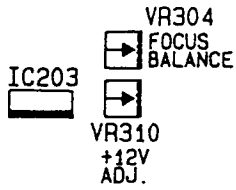

CTX

765D M/E REV: A 95/07/10

DATE U. DATE

MAIN/B

IC307

VR306
H-WIDTH
VR307
H-CENTER

P401

Q319

Q319

Q314

Q335

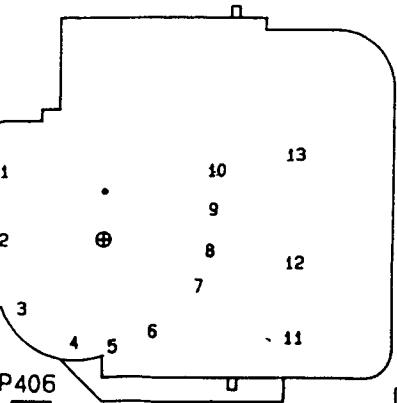

P406
LD-DOWN
X-RAY

VR401
H.V.

CRT/B

CTX
REV: A1
7650 CRT BD. 11033-013A

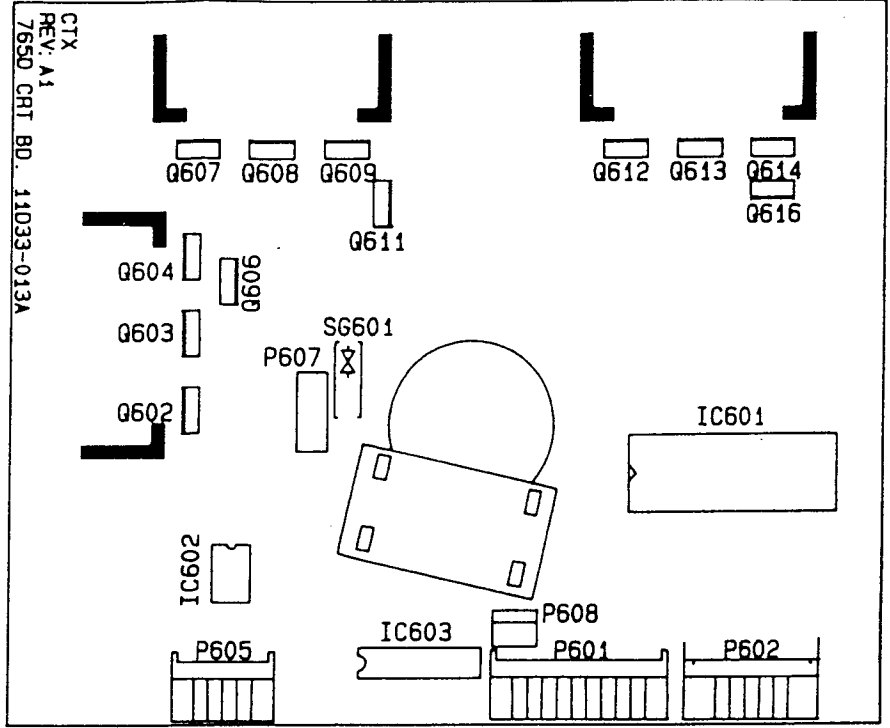

DISPLAY/B

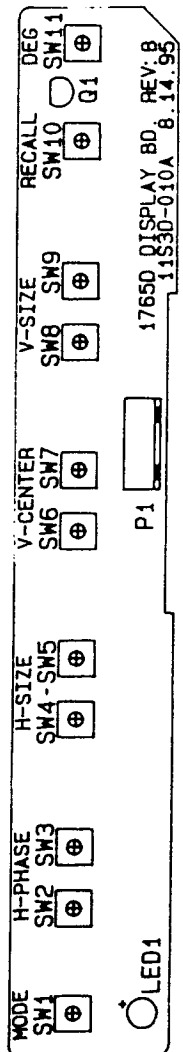

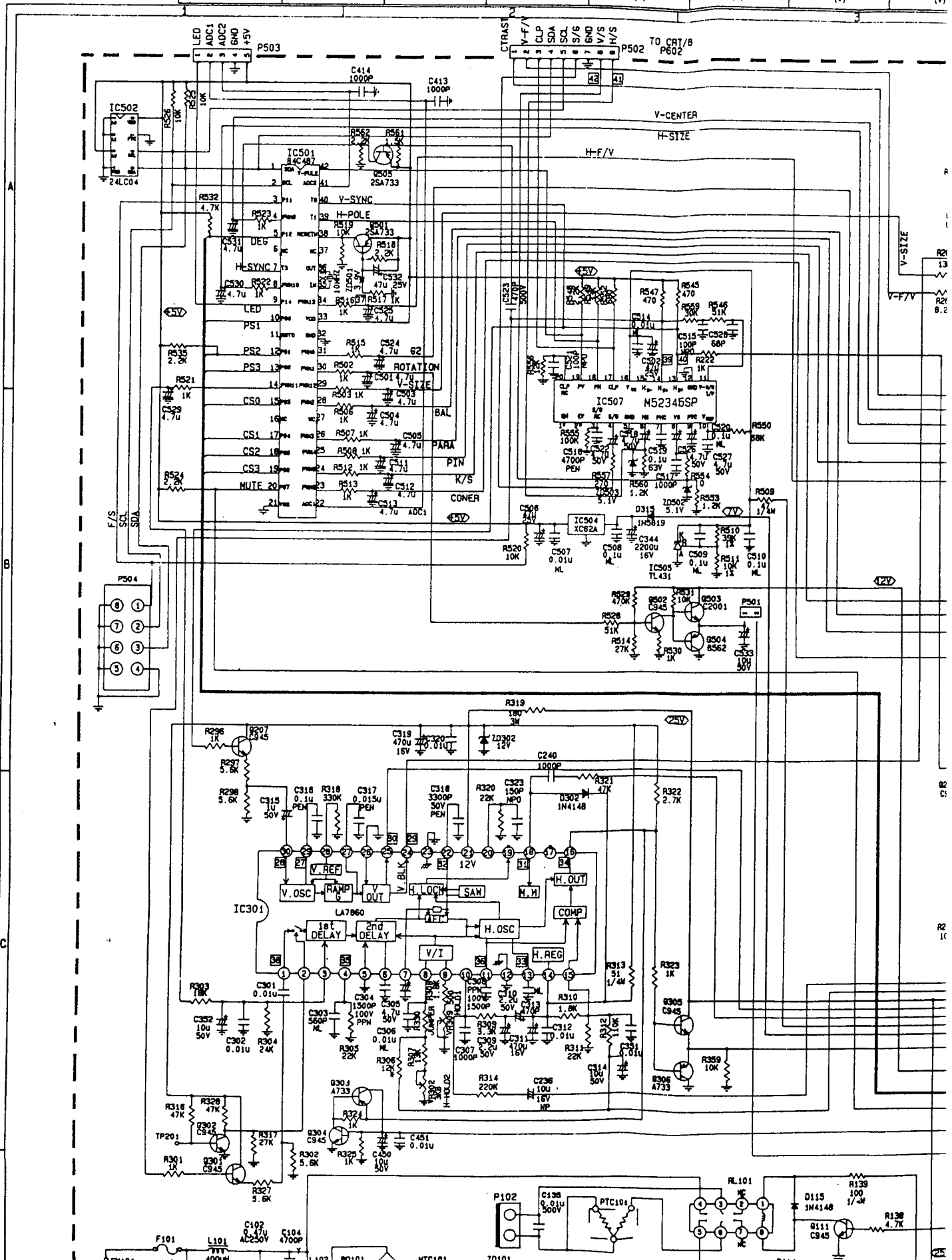
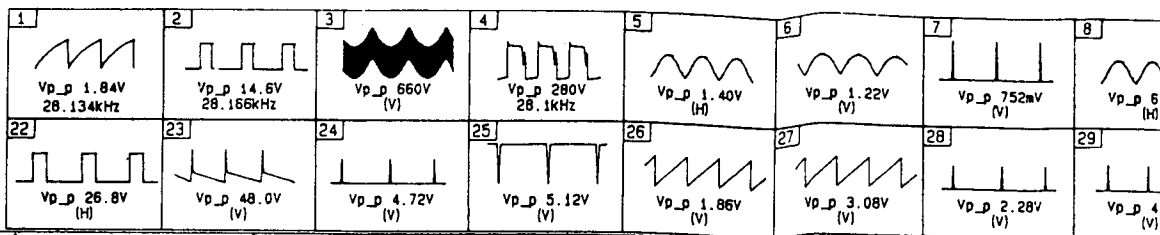

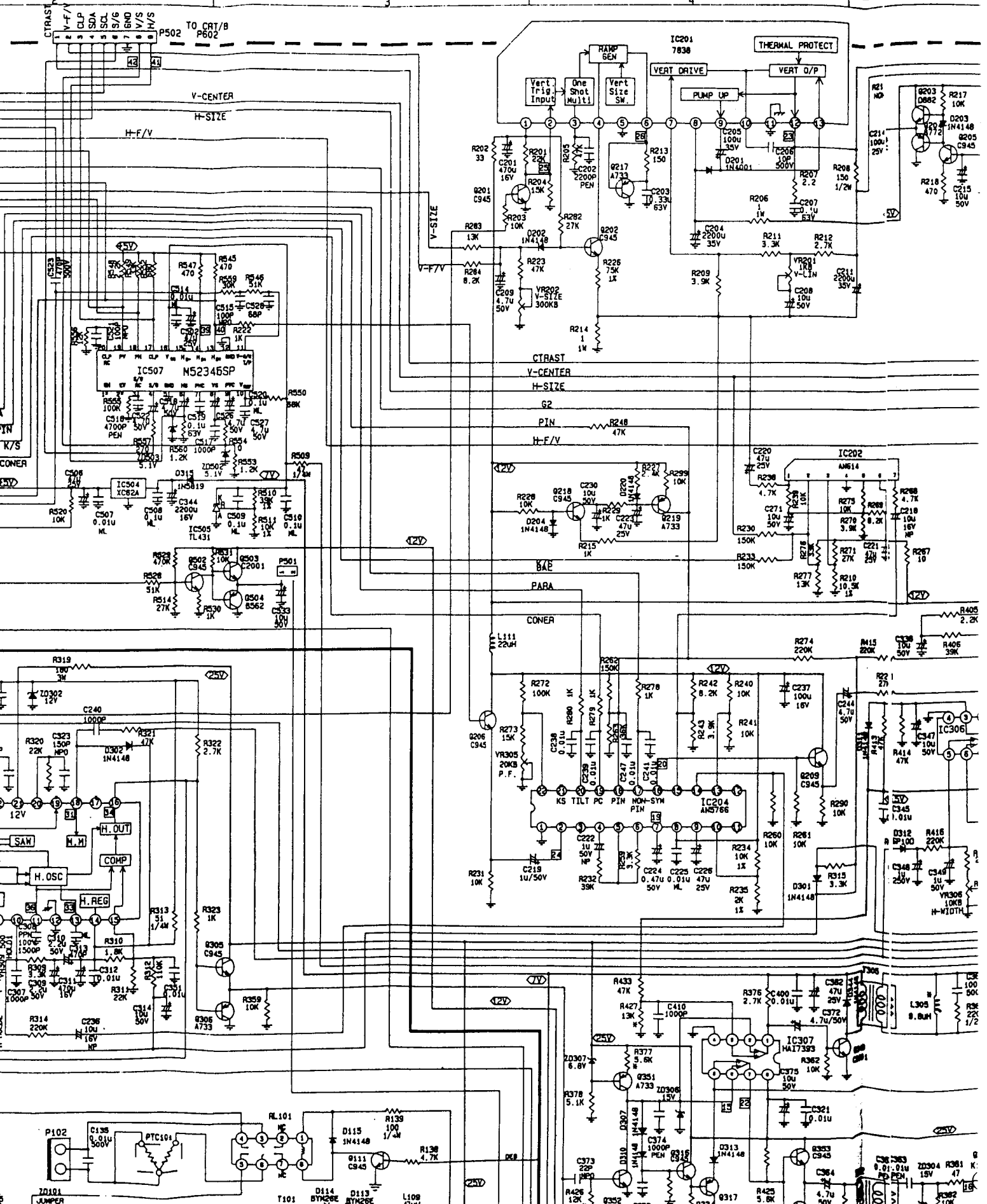
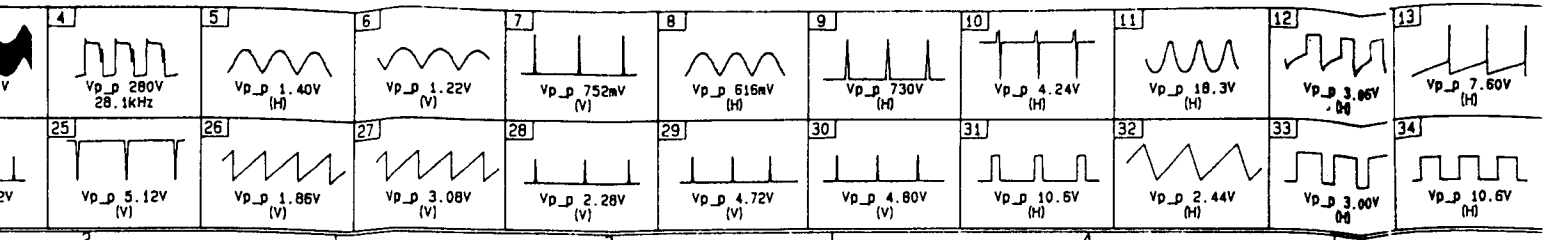

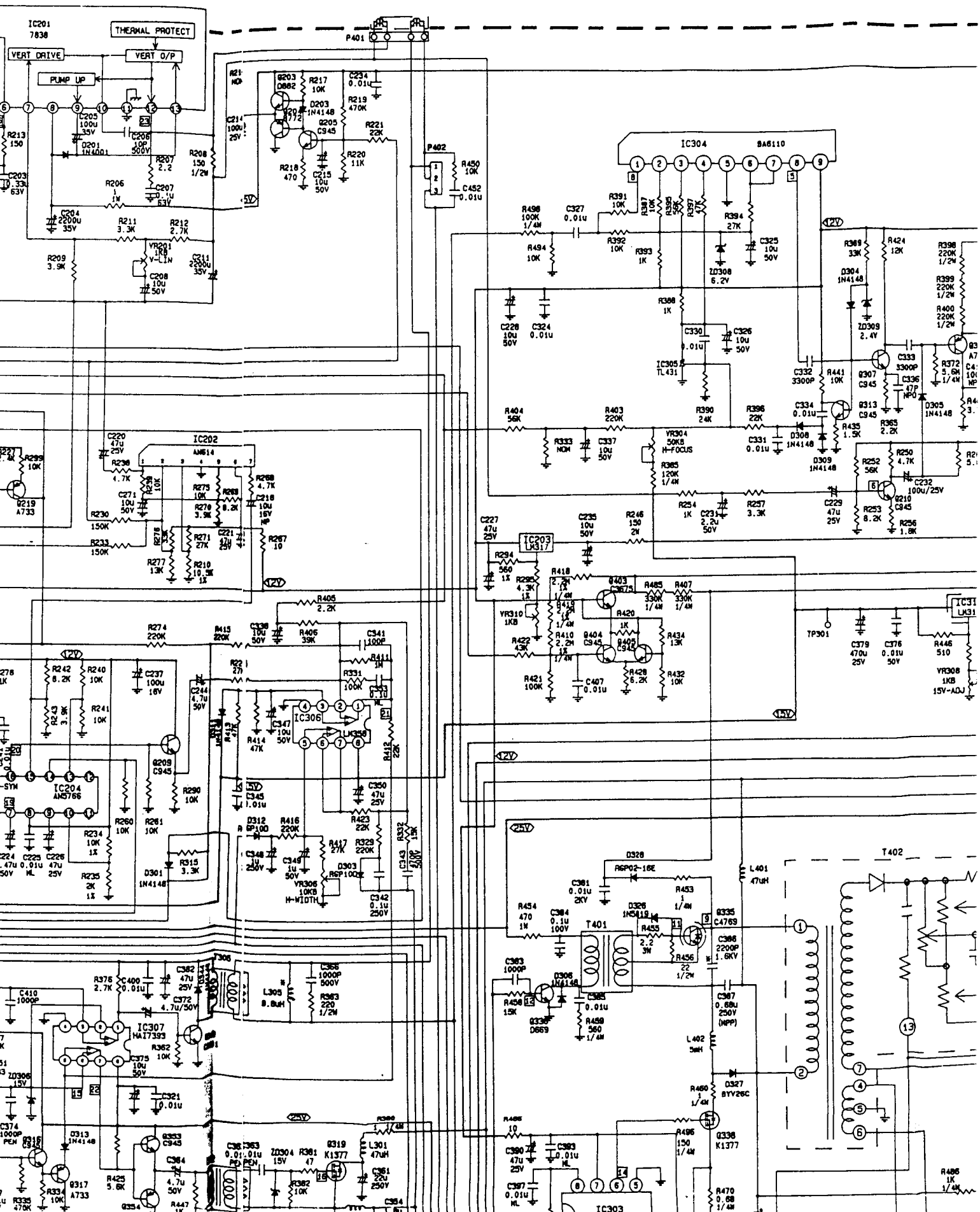
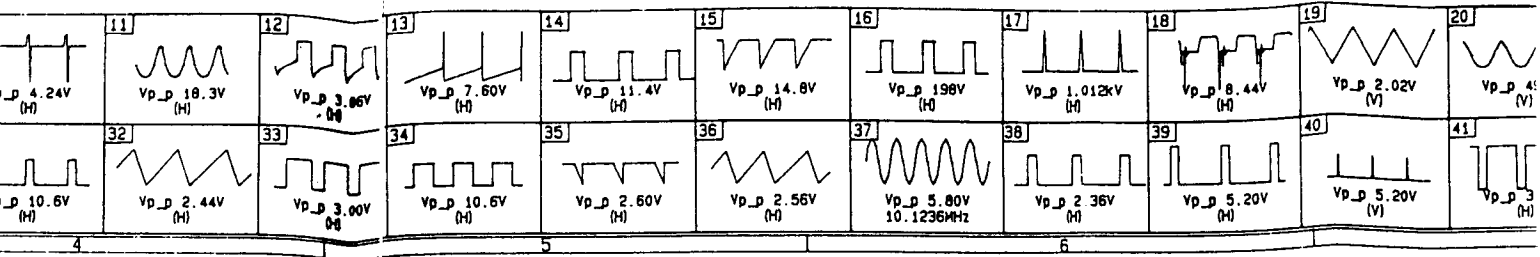

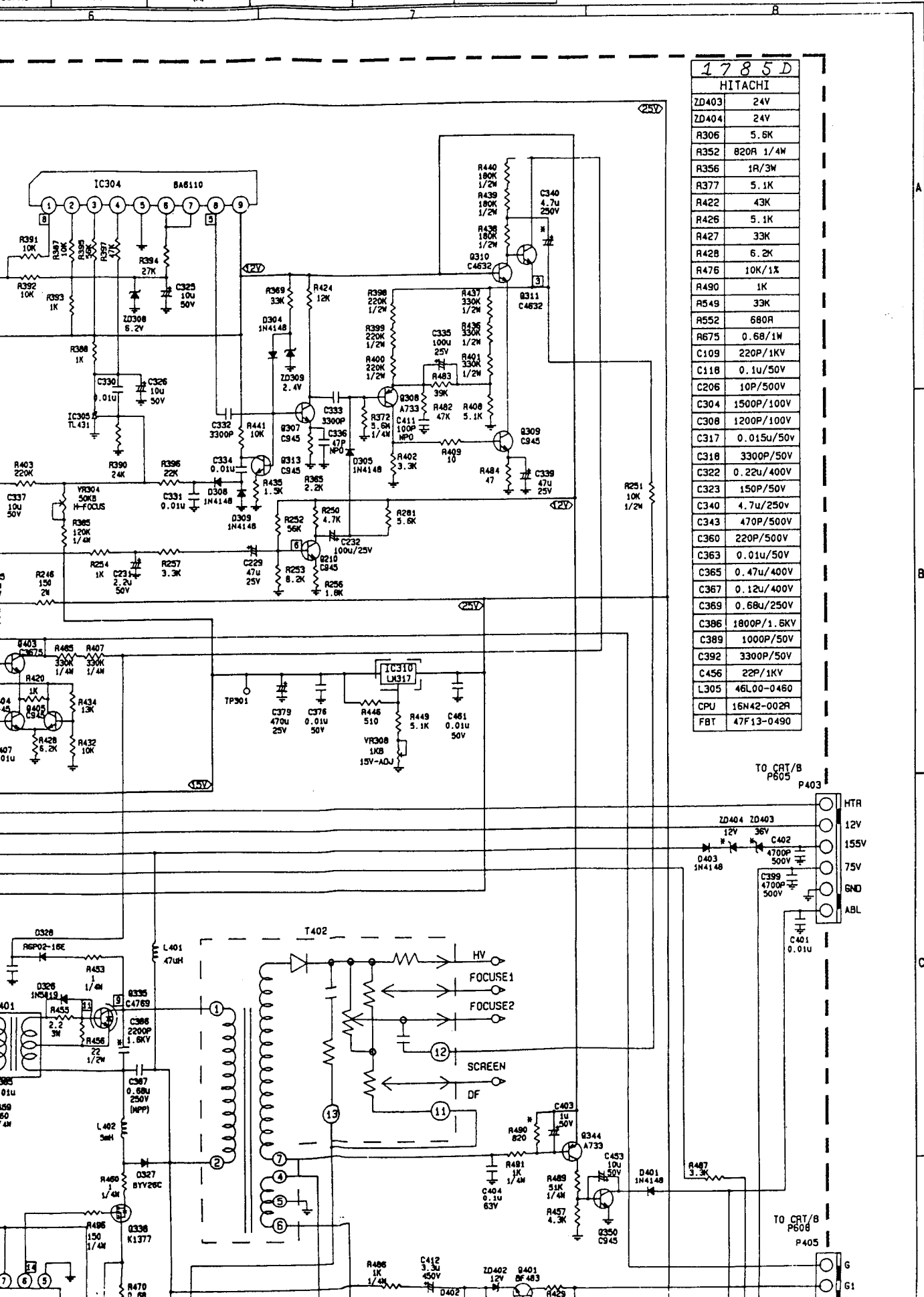
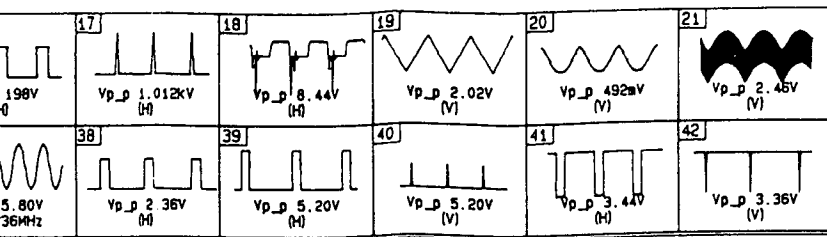

1785D
HITACHI

ZD403	24V
ZD404	24V
R306	5.6K
R352	820R 1/4W
R356	1R/3M
R377	5.1K
R422	43K
R426	5.1K
R427	33K
R428	6.2K
R476	10K/1X
R490	1K
R549	33K
R552	680R
R675	0.68/1W
C109	220P/1KV
C118	0.1u/50V
C206	10P/500V
C304	1500P/100V
C308	1200P/100V
C317	0.015u/50V
C318	3300P/50V
C322	0.22u/400V
C323	150P/50V
C340	4.7u/250V
C343	470P/500V
C360	220P/500V
C363	0.01u/50V
C365	0.47u/400V
C367	0.12u/400V
C369	0.68u/250V
C386	1800P/1.6KV
C389	1000P/50V
C392	3300P/50V
C456	22P/1KV
L305	46L00-0460
FBT	47F13-0490

TO CRT/B
P605
P403

TO CRT/B
P608
P405

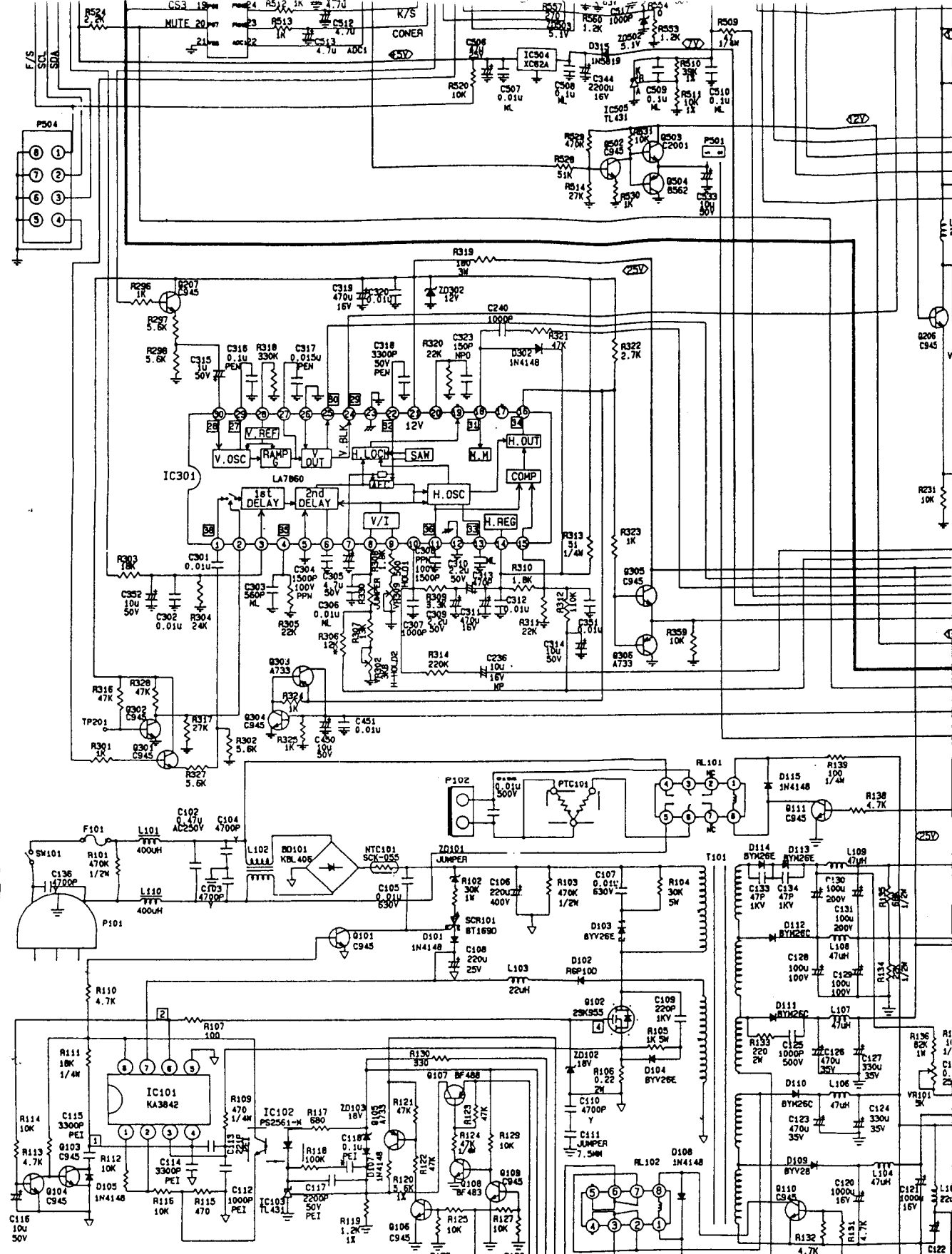

CRT ALTERNATED CONTRAST LIST

CRT REF. DES	PANASONIC	MITSUBISHI
C322	35155A3046 (0.3u)	35155A3646 (0.30u)
C365	35155-564C (0.56u)	35145-105C (1.0u)
C367	35155-8236 (0.082u)	35155-1547 (0.15u)
C369	35145-105C (1.0u)	35145-1257 (1.2u)
C371	35155-2247 (0.22u)	35155-3947 (0.39u)
R227	22215-222M (2.2k)	22215-242M (2.4k)
R306	23765-2256 (2.25/3M)	23765-1095 (1M/3M)
R427	22215-153M (15k)	22215-133M (13k)
R480	22215-244M (240k)	22215-334M (330k)
R488	22215-823M (82k)	22215-623M (62k)
ZD403	15733M2400 (24V)	15733M3000 (36V)
ZD404	15733M1200 (12V)	15733M2400 (24V)
J188/89	54.105-0758	OPEN
P402	OPEN	64835-0010
MPR1 LINE	OPEN	002352500

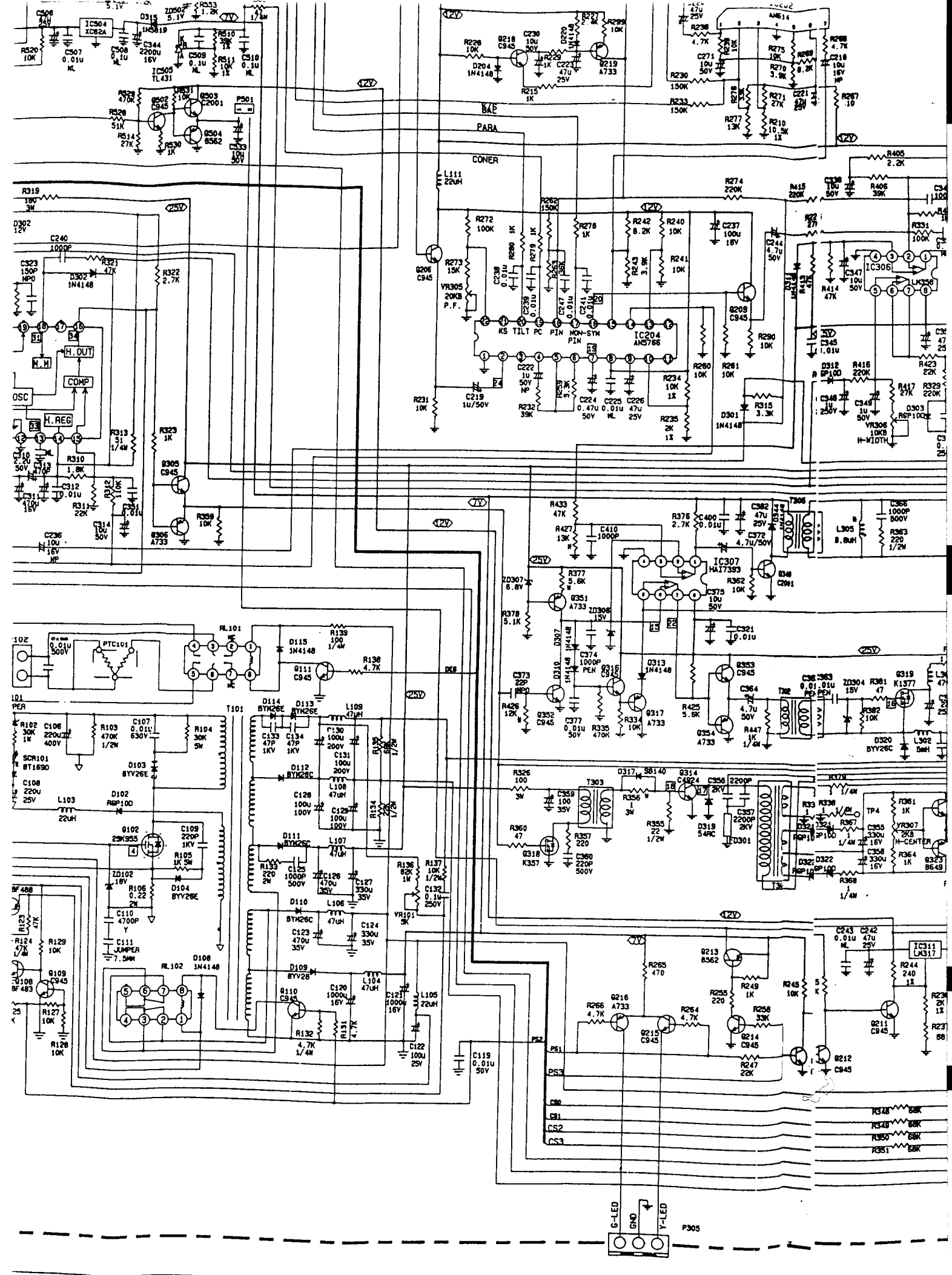

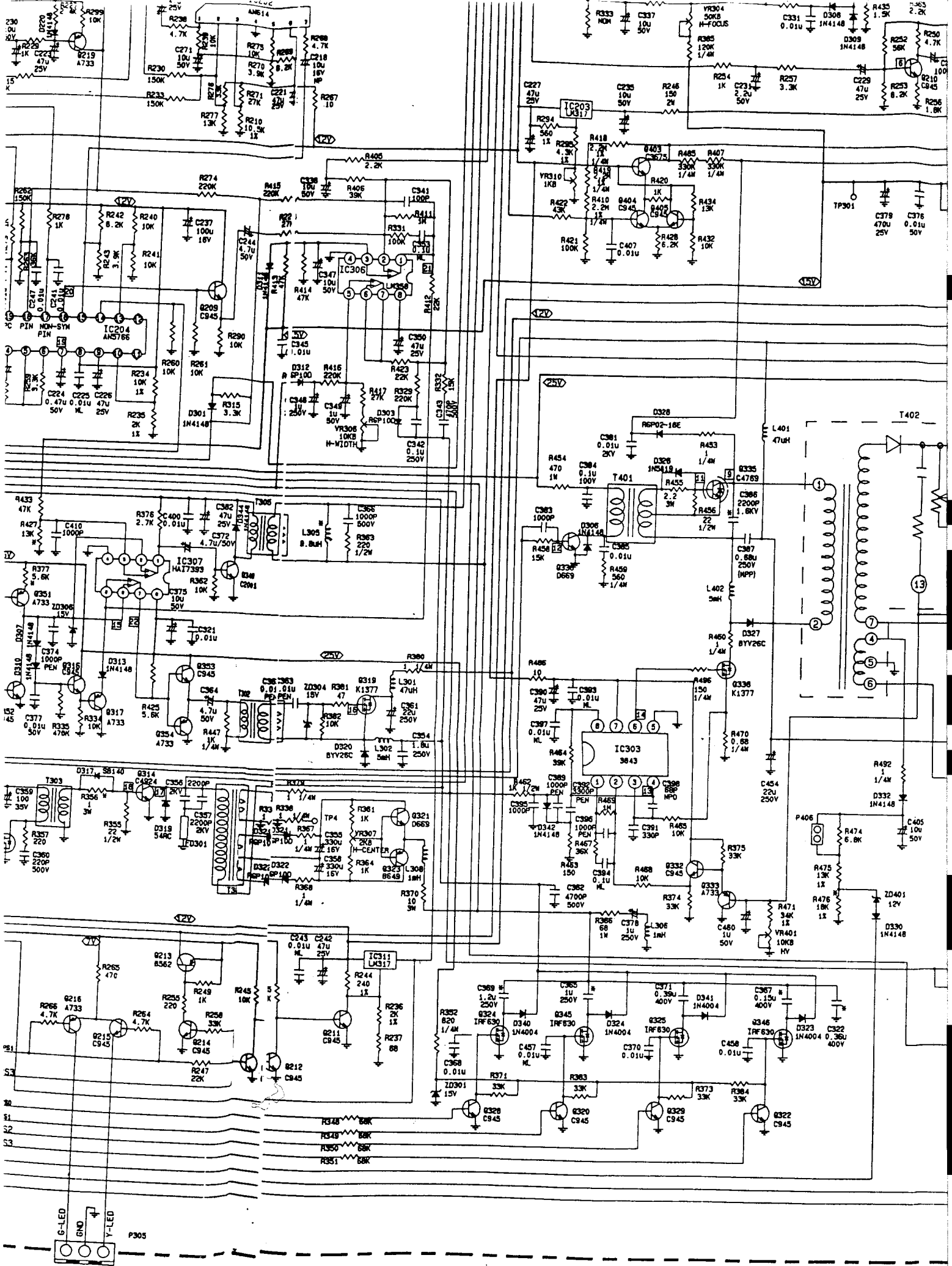

* ZD101 is use for kon

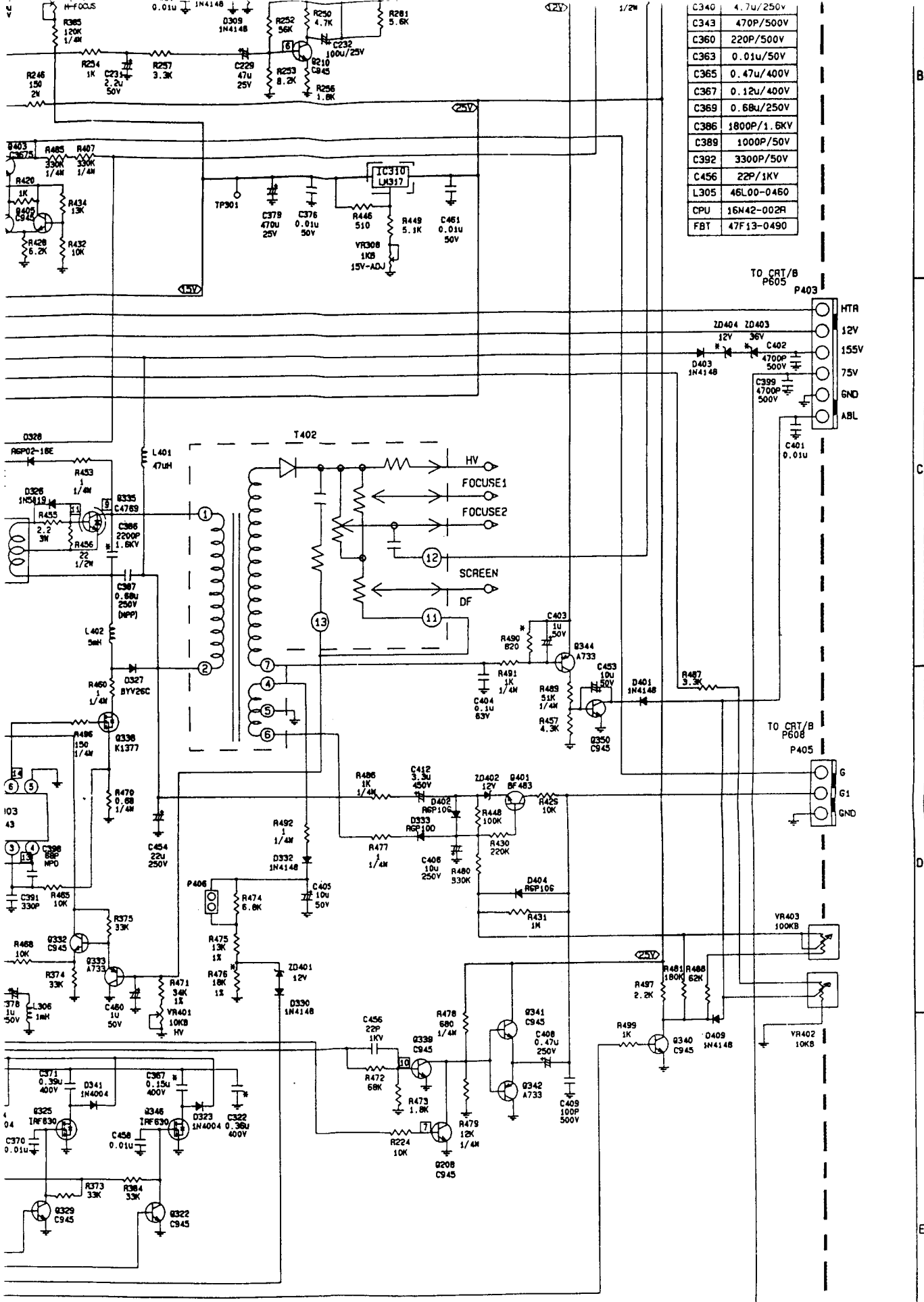

C340	4.7u/250V
C343	470P/500V
C360	220P/500V
C363	0.01u/50V
C365	0.47u/400V
C367	0.12u/400V
C369	0.68u/250V
C386	1800P/1.6KV
C389	1000P/50V
C392	3300P/50V
C456	22P/1KV
L305	46L00-0460
CPU	16N42-002R
FBI	47F13-0490

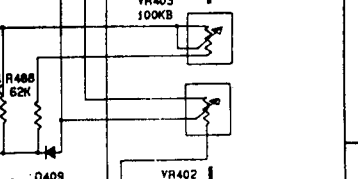
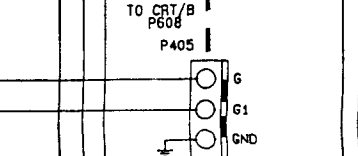
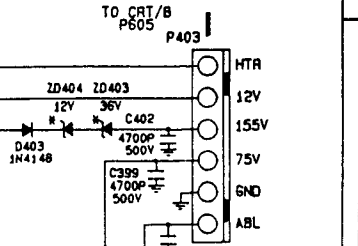

CHUNTEX ELECTRONIC CO., LTD.			
MODEL :	17650 (17650)	PRT. NO :	11531-049A
NAME :	MAIN B.D	FILE NAME :	M49B
REV :	B	DRAWN :	LIN
DATE :	1996/01/06	CHECK :	
UPDATE :	JEAN	UPDATE CHECK :	J.A.YANG

※ ZD101 is use for korea only, other areas replaced by jumper

B
C
D
E