

Screw Holes

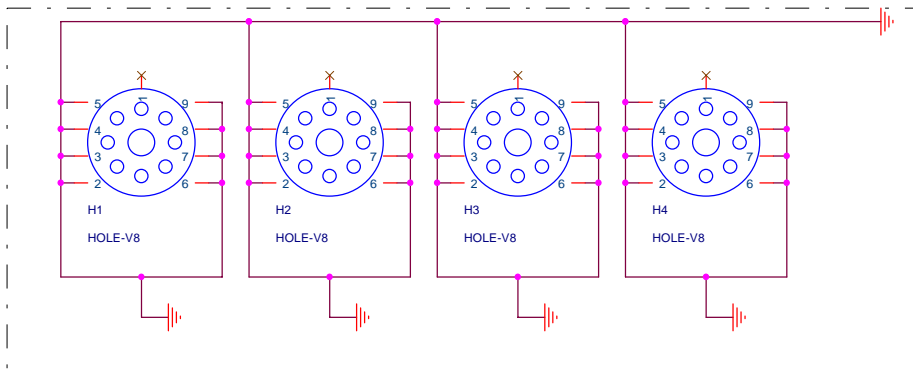

Optical Points



<b>Beng Corporation</b>			
Project Code	Model Name	OEM/ODM Model Name	
99.L8372.001	Q7T3-FP767S	NA	
Title			
INTERFACE BOARD			
Size	PCB P/N	PCB Rev.	Document Number
<Size>	48.L8301.S11	S11	99.L8372.000-C2-204-004
Date:	Tuesday, February 11, 2003	Sheet	1 of 5
Prepared By	Reviewed By	Approved By	
ANGEL HU	JAMSON LIU	DAVEN WU	

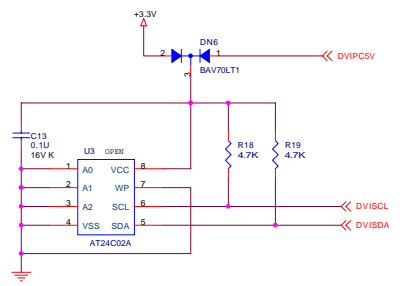
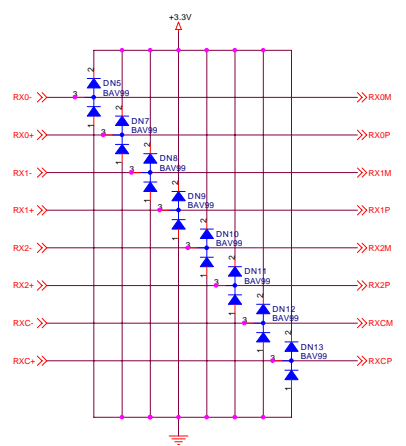
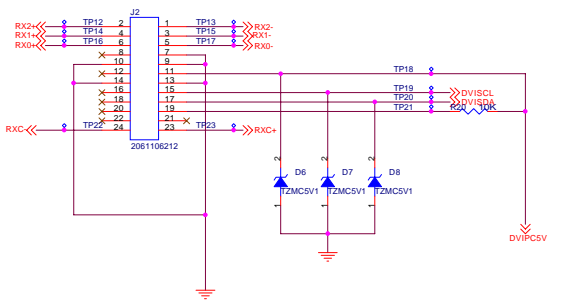
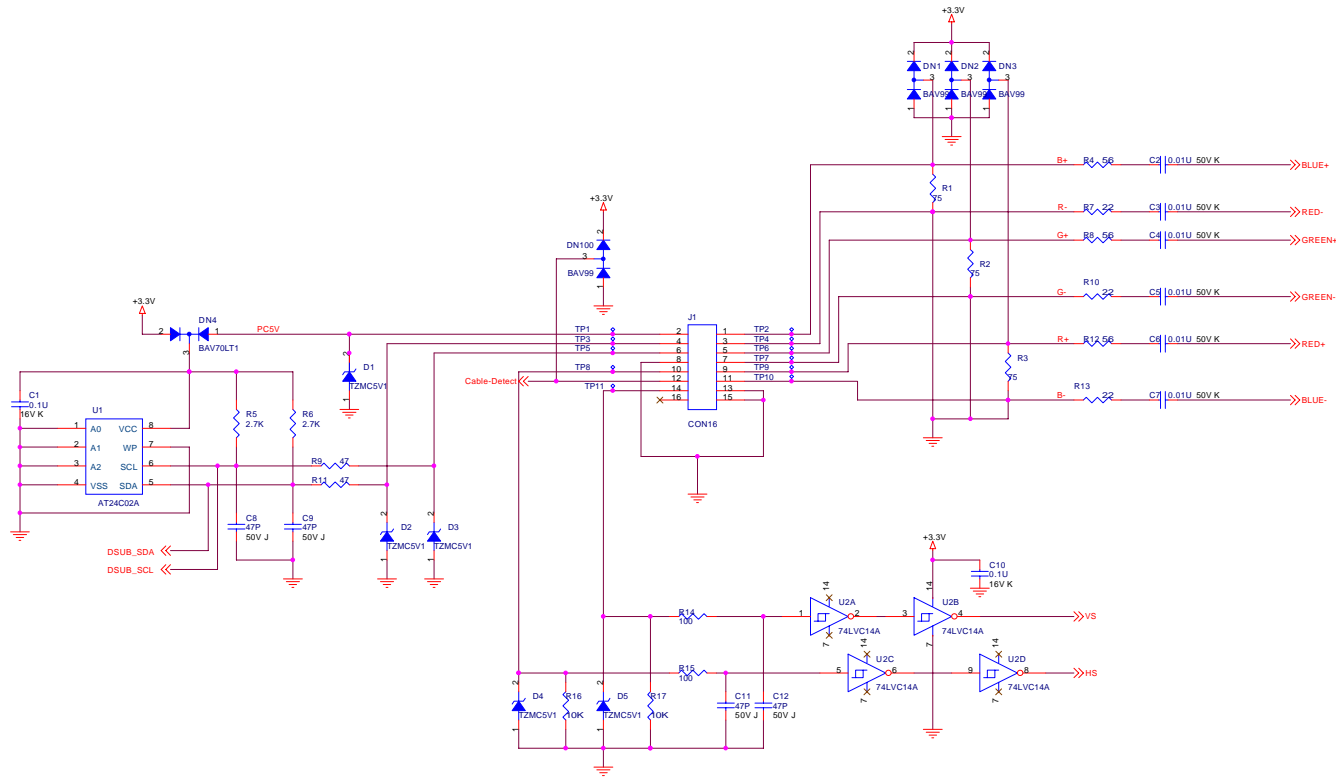

<b>Benq Corporation</b>			
Project Code	Model Name	GEM/ODM Model Name	
99.L8372.001	Q7T3-FP767S	NA	
Title			
INTERFACE BOARD			
Size	PCB P/N	PCB Rev.	Document Number
<Size>	48.L8301.S11	S11	99.L8372.000-C2-204-004
Date:	Tuesday, February 11, 2003	Sheet	2 of 5
Prepared By	ANGEL HU	Reviewed By	JAMSON LIU
		Approved By	DAVEN WU

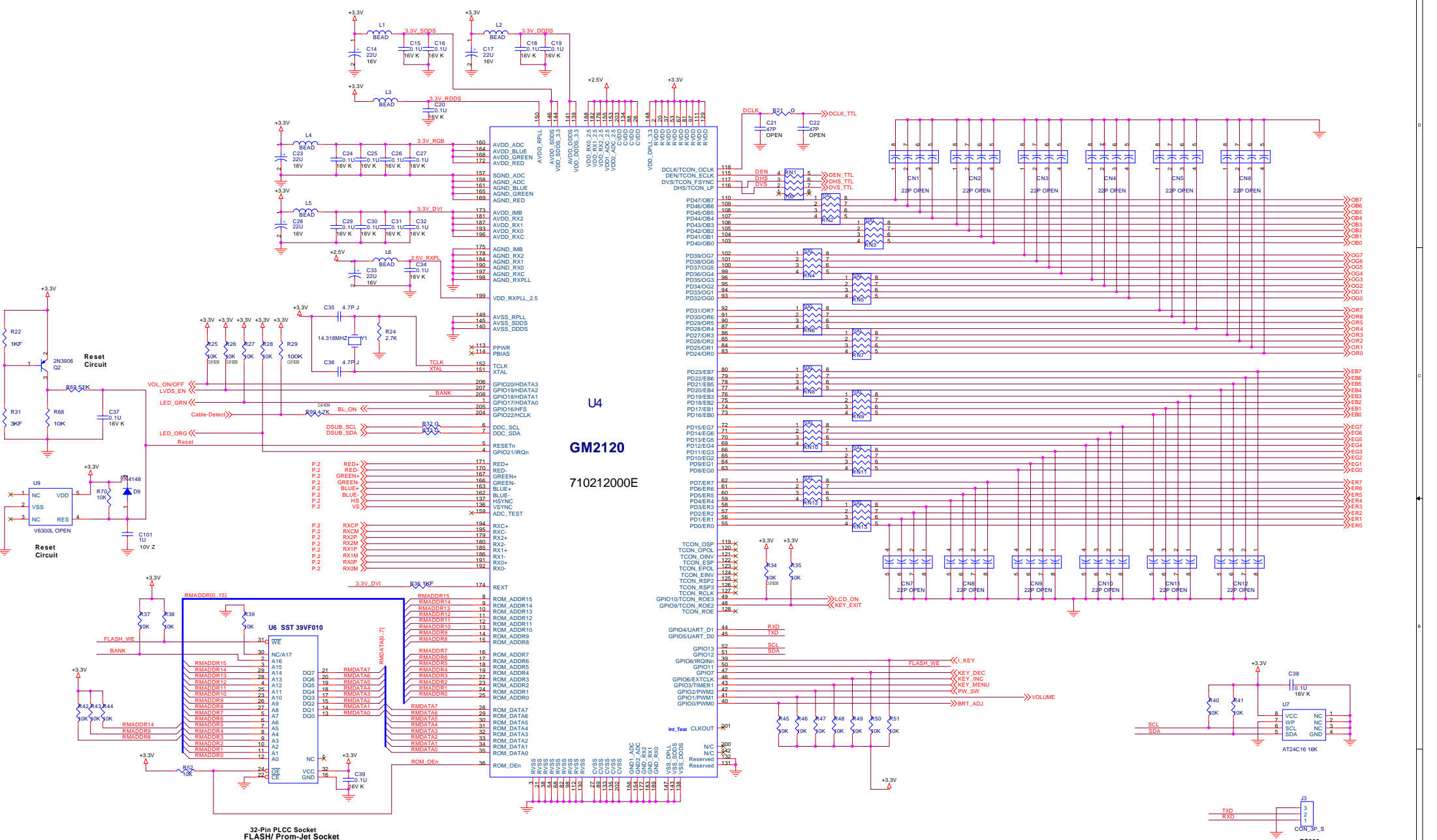

32-Pin PLCC Socket  
FLASH/ Prom-Jet Socket

**BOOTSTRAP SIGNALS**

ADDRESS	NAME	SET	DESCRIPTION
ROM_ADDR(4:0)	USER_BITS(4:0)	x	Available for reading from a status register
ROM_ADDR5	Reserved	x	If using 6-wire host protocol, program this bit to 0
ROM_ADDR6	SCLPOL	x	Determines polarity of HCLK signal
ROM_ADDR7	HOST_PROTOCOL	0	If using 6-wire host protocol, program this bit to 1
ROM_ADDR8	HOST_PORT_EN	1	GPIO(22:16) is on "Host Port" pins
ROM_ADDR9	OCM_START	1	1 = OCM becomes active after OCM_CLK is stable
ROM_ADDR(12:10)	USER_BITS(7:5)	x	Available for reading from a status register
ROM_ADDR13	OSC_SEL	0	0 = XTAL and TCLK pins are connected
ROM_ADDR14	OCM_ROM_CFG(1)	1	1 = All 48K of ROM is in external ROM

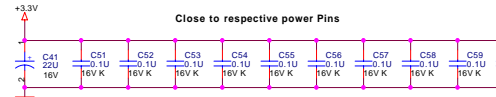
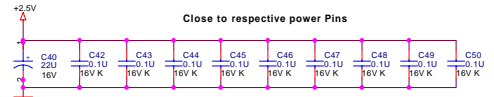

**Benq Corporation**

Project Code	Model Name	GEM/ODM Model Name
99.L8372.001	Q7T3-FP767S	NA

**INTERFACE BOARD**

Title	99.L8372.001	Document Number	99.L8372.001-C2-204-004	Rev.	0
Size	PCB P/N	PCB Rev.	S11	Sheet	3 of 5
Date:	Tuesday, February 11, 2003	Released By:	JAMSON LIU	Approved By:	DAVEN WU
Prepared By:	ANGEL HU	Released By:	JAMSON LIU	Approved By:	DAVEN WU

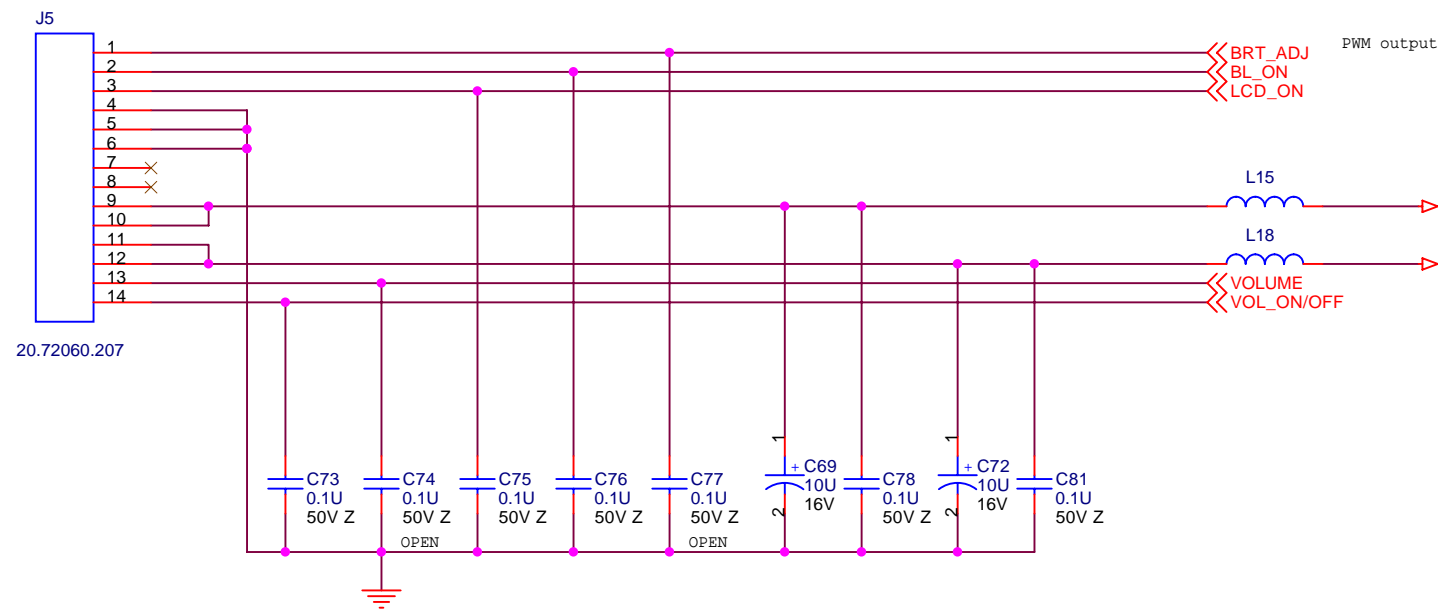
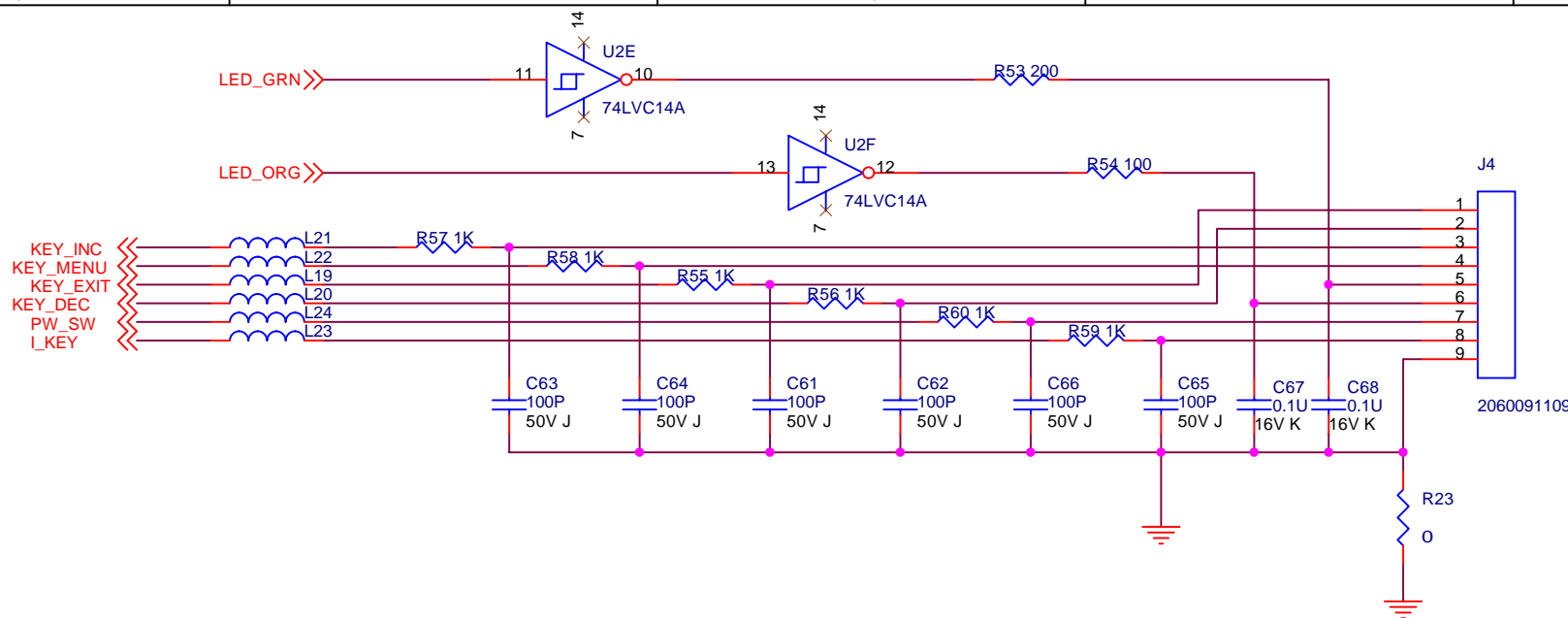

PWM output first, it must be "H" when no work.

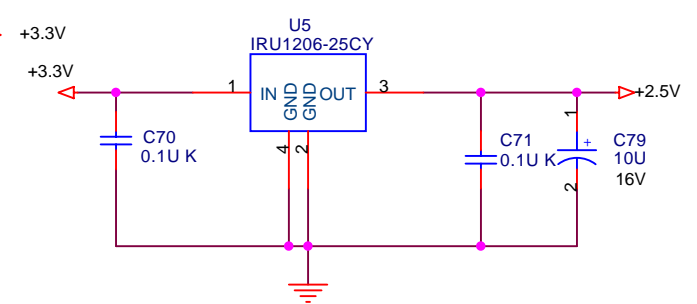

<b>Benq Corporation</b>				
Project Code		Model Name		OEM/ODM Model Name
99.L8372.001		Q7T3-FP767S		NA
Title INTERFACE BOARD				
Size	PCB P/N	PCB Rev.	Document Number	Rev.
<Size>	48.L8301.S11	S11	99.L8372.000-C2-204-004	0
Date: Tuesday, February 11, 2003			Sheet 4 of 5	
Prepared By		Reviewed By		Approved By
ANGEL HU		JAMSON LIU		DAVEN WU

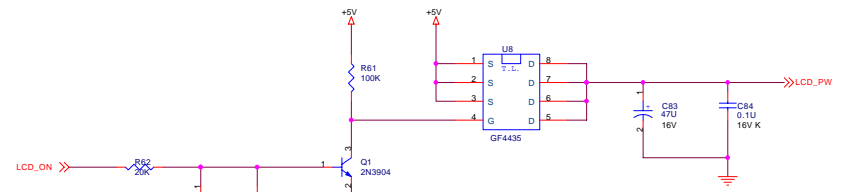
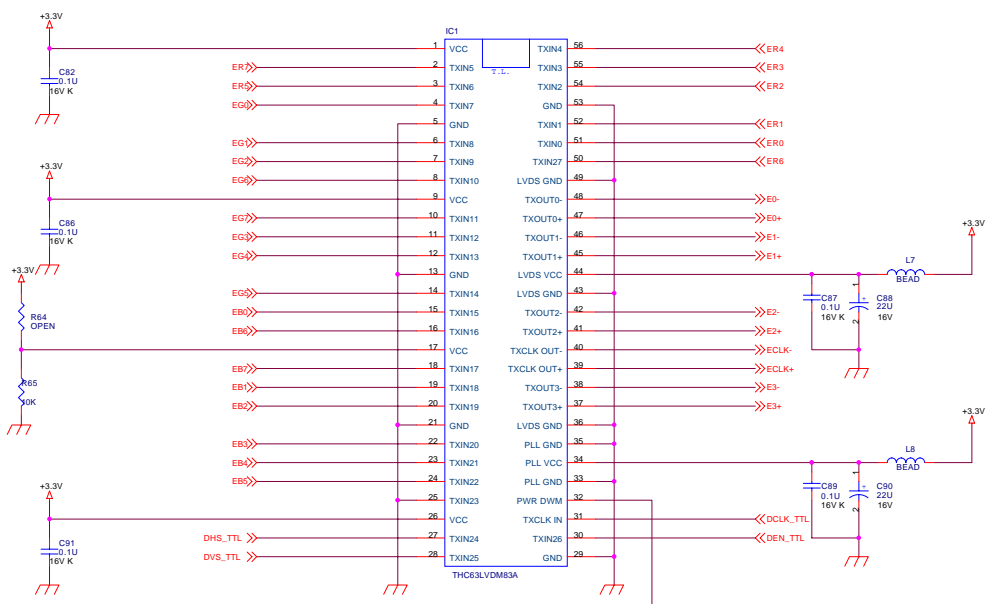

"L" Falling edge trigger  
 "H" Rising edge trigger

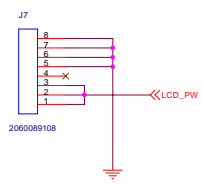
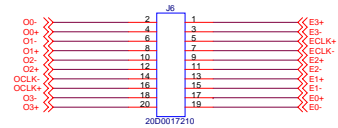
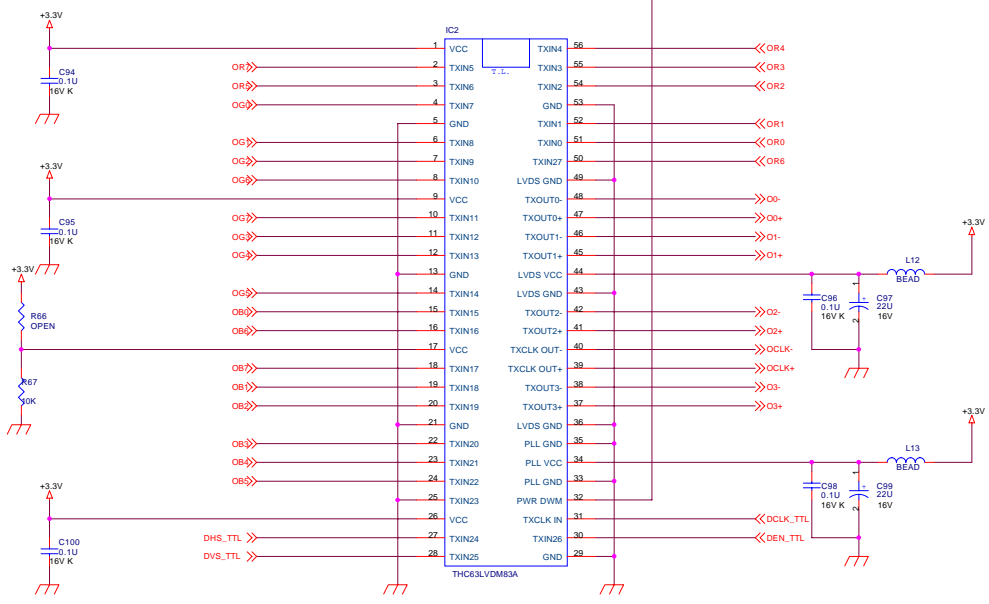

<b>Benq Corporation</b>			
Project Code	Model Name	GEM/ODM Model Name	
99.L8372.001	Q7T3-FP767S	NA	
Title: INTERFACE BOARD			
Size	PCB P/N	PCB Rev.	Document Number
<Size>	48.L8301.S11	S11	99.L8372.000-C2-204-004
Date:	Tuesday, February 11, 2003	Sheet	5 of 5
Prepared By:	ANGEL HU	Reviewed By:	JAMSON LIU
		Approved By:	DAVEN WU

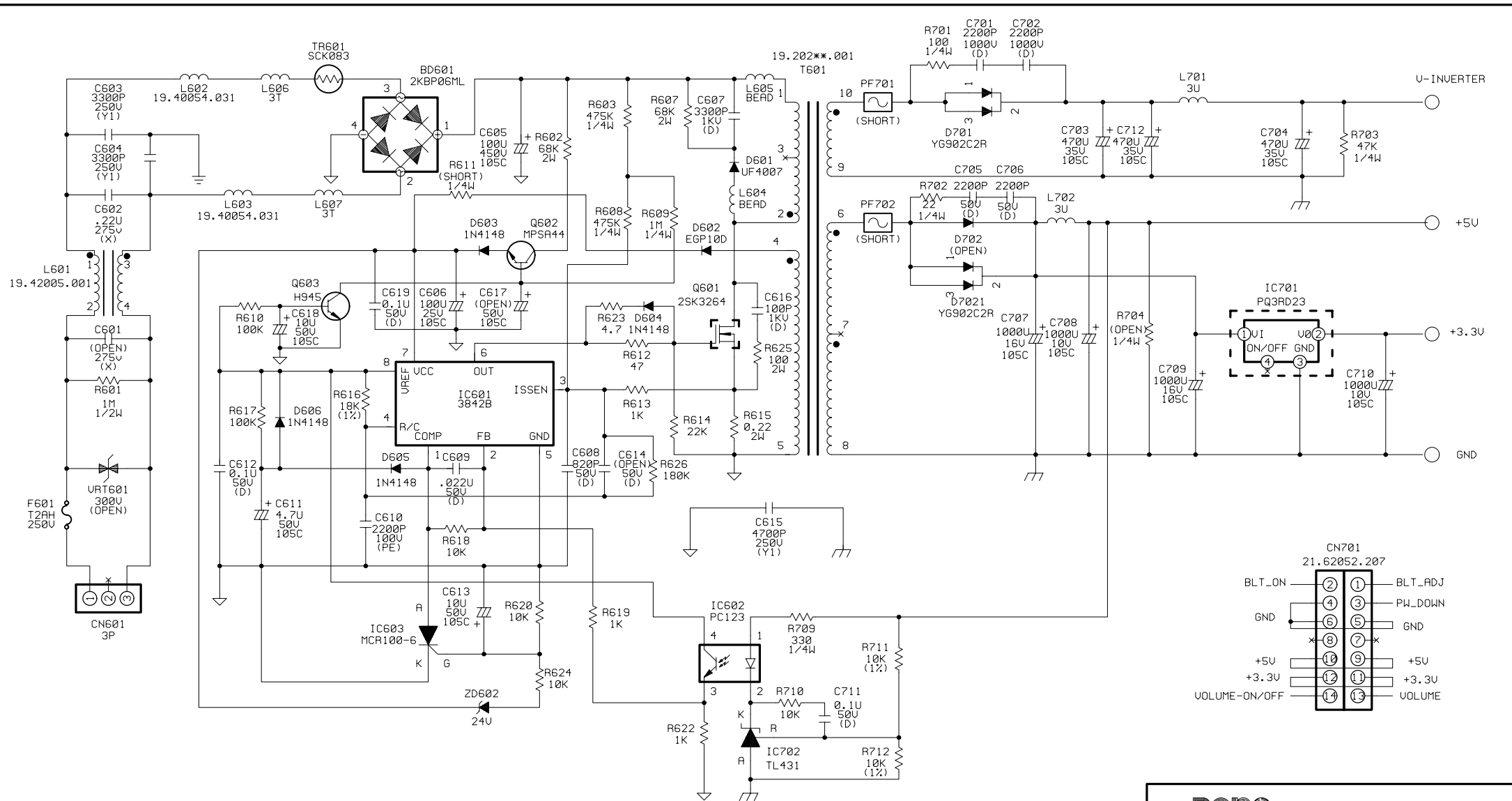

Q7T3-FP767 POWER BOARD SCHEMATICS

SIZE A4	L8302S11.SCH	Project Code. 99.L8372.001	REV. 0
DATE : 2/11/2003	Sheet 1 OF 2		
Doc.No. 99.L8372.000-C2-204-005			
Prepared By ANGEL HU 2/11/2003	Reviewed By GEORGE SHEU 2/11/2003	Approved By H.J. WONG 2/11/2003	

- NOTES:
- Resistor values are in ohm,K=1,000 ohm,M=1,000,000 ohm
  - All resistors are 1/8 watt,5% except where otherwise indicated
  - $\text{---} \text{---} \text{---}$  Represents PCB common ground.

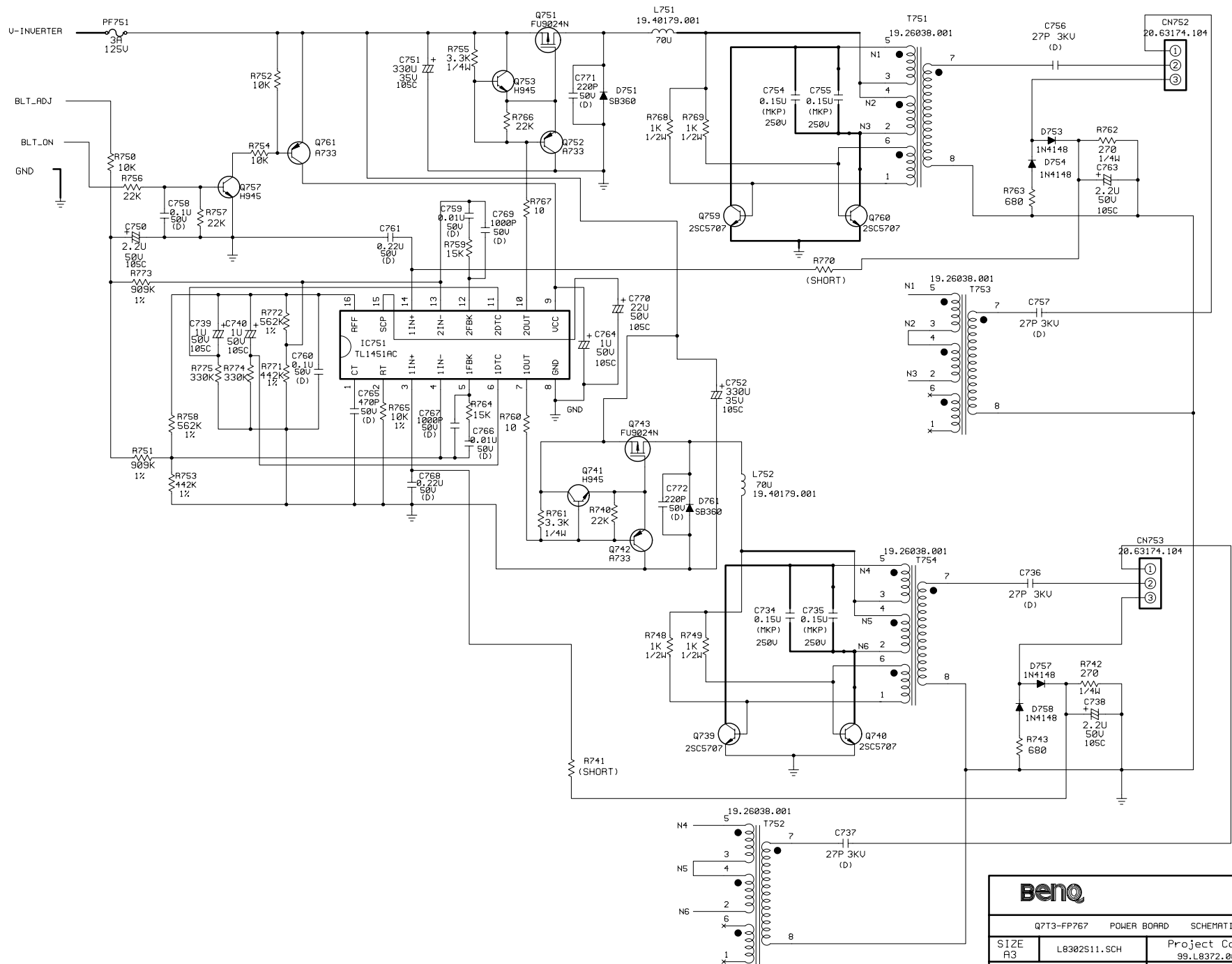

NOTES: 1. Resistor values are in ohm, K=1,000 ohm, M=1,000,000 ohm  
 2. All resistors are 1/8 watt, 5% except where otherwise indicated  
 3.  $\nabla$   $\nabla$   $\nabla$  Represents PCB common ground.

<b>BenQ</b>			
Q7T3-FP767 POWER BOARD SCHEMATICS			
SIZE A3	L8302S11.SCH	Project Code. 99.L8372.001	REV. 0
DATE : 2/11/2003	Sheet 2 OF 2		
Doc. No. 99.L8372.000-C2-204-005			
Prepared By ANGEL HU 2/11/2003	Reviewed By GEORGE SHEU 2/11/2003	Approved By H. J. WONG 2/11/2003	