



Applicable Country & Regions: Europe

Service Manual for BenQ:

LCD G2020HDA

(D-SUB+ Black Bezel)



Product Service Manual – Level 1~2

Version: 2nd
Date:09-03-2009

Notice:

For RO to input specific “Legal Requirement” in specific NS regarding to responsibility and liability statements.

Please check BenQ’s eSupport web site, <http://esupport.benq.com>, to ensure that you have the most recent version of this manual.

First Edition (April, 2009)

© Copyright BenQ Corporation 2009. All Right Reserved.

Content Index

Abbreviations & Acronyms	3
1. About this Manual	5
1.1 <i>Important</i>	5
1.2 <i>Trademark</i>	5
2. Introduction	5
2.1 <i>RoHS (2002/95/EC) Requirements – Applied to all countries require RoHS</i>	5
2.2 <i>Safety Notice</i>	6
2.3 <i>Compliance Statement</i>	6
3. General Description	7
4. Related service information	8
5. Product Overview	8
5.1 <i>Monitor Specifications</i>	8
5.2 <i>Packing</i>	10
Level 1 Cosmetic / Appearance / Alignment Service	12
<i>Visual Inspection & Cleaning</i>	12
<i>Software/Firmware Upgrade Process</i>	12
<i>DDC instruction</i>	15
<i>Adjustment / Alignment Procedure</i>	21
Level 2 Circuit Board and Standard Parts Replacement	30
<i>Product Exploded View</i>	30
<i>Six angles' view</i>	31
<i>Product Disassembly</i>	32
<i>Block Diagram</i>	36
<i>Schematic Diagram</i>	38
<i>Troubleshooting Guide</i>	46
<i>PCB LAYOUT</i>	54
Appendix 1 – Screw List / Torque	56

Abbreviations & Acronyms

A	
ADC	Analog to Digital Converter
AFC	Automatic Frequency Control: control signal used to tune to the correct frequency
B	
BenQ	BenQ Corporation
BTSC	Broadcast Television System Committee
C	
CPU	Central Process Unit
CVBS	Composite Video Blanking and Synchronization
D	
DLP	Digital Light Processing / Texas Instruments®
DMD	Digital Micromirror Device
DRAM	Dynamic RAM
DVI	Digital Video Interface
DVI-I	Digital Video Interface-Integrated
E	
EEPROM	Electrically Erasable and Programmable Read Only Memory
F	
FLASH	FLASH memory
G	
G-TXT	Green Teletext
H	
HDMI	High Definition Multimedia Interface, digital audio and video interface
HP	Head Phone
I	
I ² C	Integrated IC bus
L	
LED	Light Emitting Diode
LVDS	Low Voltage Differential Signal, data transmission system for high
M	
MOSFET	Metal Oxide Semiconductor Field Effect Transistor
N	

NC	Not Connected
NVM	Non Volatile Memory: IC containing TV related data (for example, options)
O	
OSD	On Screen Display
P	
PC	Personal Computer
PCB	Printed Circuit Board (or PWB)
R	
RC	Remote Control transmitter
RGB	Red, Green and Blue. The primary color signals for TV. By mixing levels of R, G and B, all colors (Y/C) are
ROM	Read Only Memory
S	
SDA	Data signal on I ² C bus
SDRAM	Synchronous DRAM
SW	Sub Woofer / Software
T	
THD	Total Harmonic Distortion
V	
VGA	Video Graphics Array
Y	
YPbPr	Component video (Y= Luminance, Pb/ Pr= Color difference signals B-Y and R-Y, other amplitudes w.r.t. to YUV)
Y/C	Video related signals: Y consists of luminance signal, blanking level and sync; C consists of color signal.

1. About this Manual

The purpose of Service Manual is to provide a guide line to engineers to repair different models. The appearance and capability is introduced in this Service Manual. It is better for repair engineer to have a rough idea of this model through reading the Service Manual. Please do pay attention to the item part of the disassembly when repair the machine and also do the protection of panel any time. When repairing the circuit board, please follow the requirement of RoHS and refer to the circuit diagram and repairing process that attached in the Service Manual. The method of firmware updated, the way of using the menu and some information that may be used when repairing are also attached in the Service Manual that provide repair engineer various choice.

1.1 Important

Only trained service personnel who are familiar with this BenQ Product shall perform service or maintenance to it. Before performing any maintenance or service, the engineer MUST read the "Important Safety Information".

1.2 Trademark



2. Introduction

This section contains general service information, please read through carefully. It should be stored for easy access place.

2.1 RoHS (2002/95/EC) Requirements – Applied to all countries require RoHS.

The RoHS (Restriction of Hazardous Substance in Electrical and Electronic Equipment Directive) is a legal requirement by EU (European Union) for the global electronics industry which sold in EU and some counties also require this requirement. Any electrical and electronics products launched in the market after June 2006 should meet this RoHS requirements. Products launched in the market before June 2006 are not required to compliant with RoHS parts. If the original parts are not RoHS complaints, the replacement parts can be non ROHS complaints, but if the original parts are RoHS compliant, the replacement parts MUST be RoHS complaints.

If the product service or maintenance require replacing any parts, please confirming the RoHS requirement before replace them.

2.2 Safety Notice

1. Make sure your working environment is dry and clean, and meets all government safety requirements.
2. Ensure that other persons are safe while you are servicing the product.
3. DO NOT perform any action that may cause a hazard to the customer or make the product unsafe.
4. Use proper safety devices to ensure your personal safety.
5. Always use approved tools and test equipment for servicing.
6. Never assume the product's power is disconnected from the mains power supply. Check that it is disconnected before opening the product's cabinet.
7. Modules containing electrical components are sensitive to electrostatic discharge (ESD). Follow ESD safety procedures while handling these parts.
8. Some products contain more than one battery. Do not disassemble any battery, or expose it to high temperatures such as throwing into fire, otherwise it may explode.
9. Refer to government requirements for battery recycling or disposal.

2.3 Compliance Statement

Caution: This Optical Storage Product contains a Laser device. Refer to the product specifications and your local Laser Safety Compliance Requirements.

3. General Description

This new LCD (Liquid Crystal Display) monitor BenQ G2020HDA offers numerous features and functions, for example:

- TFT display (Thin Film Transistor; active matrix)
- minimal space requirements thanks to slim casing
- optimum ergonomic characteristics (totally distortion-free, excellent picture definition and color purity right into the corners)
- high degree of brightness and good contrast
- high resolution (1600x900)
- presentation of up to 16.7 million colors (in conjunction with an appropriate graphics card)
- automatic scanning of horizontal frequencies from 24 to 83 kHz and refresh rates (vertical frequencies) from 50 to 76 Hz (absolutely flicker-free)
- freely adjustable color alignment for matching the screen colors to the colors of various input and output devices
- convenient operation via integrated OSD (On-Screen-display) menu
- VESA-DDC compatibility
- plug & play capability
- power management for reducing power consumption when the computer is not in use
- compliance with the recommendations in accordance with TCO'03

This operating manual contains important information you require to start up and run your LCD monitor.

This specification defines the requirements for the 20"W MICROPROCESSOR based Multi-mode supported high resolution color LCD monitor. This monitor can be directly connected to general 15-pin D-sub VGA connector, also supports VESA DPMS power management and plug & play function.

Additional information

Due to the nature of liquid crystal display (LCD) technology, the picture resolution is always fixed. For the best display performance, please set the display resolution to 1600x900 pixels with an aspect ratio of 16:9. This is called "Native Resolution" or maximal resolution – that is, the clearest picture. Lower resolutions are displayed on a full screen through an interpolation circuit. Image blurring across pixel boundaries can occur with the interpolated resolution depending upon the image type and its initial resolution.

4. Related service information

This Service Manual contains general information. There are 2 levels of service:

Level 1: Cosmetic / Appearance / Alignment Service

Level 2: Circuit Board or Standard Parts Replacement

Service Web Site

eSupport URL: <http://esupport.benq.com>

5. Product Overview

5.1 Monitor Specifications

		G2020HDA
Display	Panel model	SEC/LG/AUO/ CMO/CPT
	Panel Type (TN / VA / IPS)	TN
	Panel Size	20"W (2 lamp)
	Display Area	442.8x249.2mm
	Native. Resolution	1600 x 900
	Pixel Pitch	0.2768x0.2768
	Brightness (Typ.)	250 nits
	Contrast Ratio (Typ.) / DCR (Min.)	1000:1 (Panel) /40000:1 (DCR); Min :20000:1
	Viewing Angle (H/V), CR \geq 10	160/160
	Display Colors	16.7M (6bit+Hi-FRC)
	Response Time	5ms (Tr+Tf)
	GtG response Time	N/A
	NTSC ratio	72%
Video	BenQ Senseye™ Technology	Yes
	BenQ Senseye™ Preset Modes	5 Modes (by hotkey) Standard / Movie / Dynamic / Photo / s-RGB
	Color Temperature Selection	Normal (6500°K) / Reddish (5800°K) / Bluish (9300°K) / User Mode
	Hor. Frequency (KHz)	24kz~83Kz
	Ver. Frequency (Hz)	50Hz~76Hz
	Video Bandwidth (MHz)	165Mhz

Audio	Speakers (built-in)	NA
Input/Output	PC Video Input	D-Sub
	Audio line in	NA
	Earphone Jack	NA
Power Supply	Voltage Rating	AC: 100~240V (Built-in)
	Power-On Mode	28W
	Standby Mode	<1W
	Power Off Mode	<0.5W
Mechanical Design	Chassis Colors	Glossy black
	Carton	Brown Carton with at least C flute
	Power LED	Green (ON)/ Amber (Standby)
	Tilt (Up / Down)	20° ~ -5°
	VESA Wall Mount	100 x 100mm
	Kensington Lock	Yes
	Container Loading (40')	>1600
Container Loading (20')	>800	
Multi-language Support	OSD	17 Languages (English / Francais / Deutsch / Italiano / Espanol / Polish / Czech / Hungarian / Serbo-croatian / Romanian / Netherlands / Russian / Swedish / Protuguese / Japanese / Chinese / S-Chinese)
Other feature	Vista	Vista Basic
Accessories		VGA cable, power cord, warranty card, quick start guide, CD manual
Regulation Approvals		Refer to the worksheet "RFQ-Regulatory"

5.2 Packing

When packing the monitor into the carton, please follow the pictures as below.



Using the EPE bag to pack the monitor without base



Using the EPS to pack the monitor

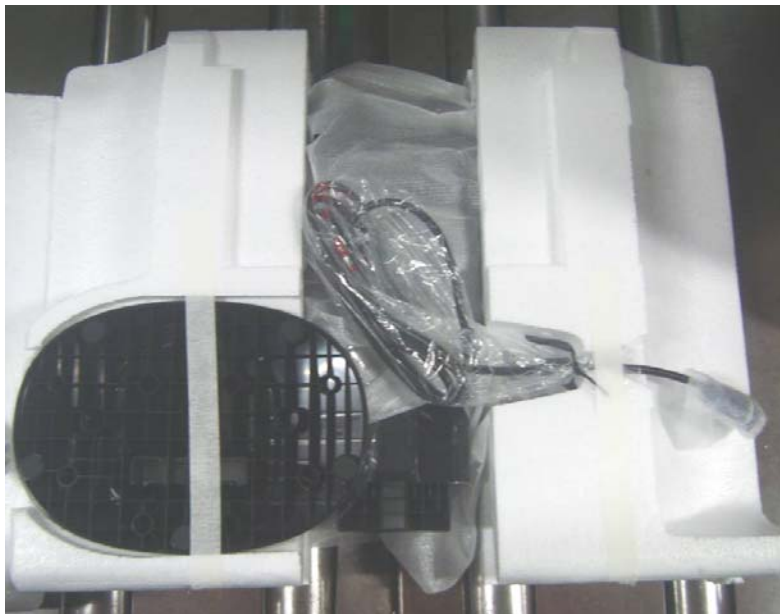

Putting the base and D-SUB cable in the position as the picture shows above.

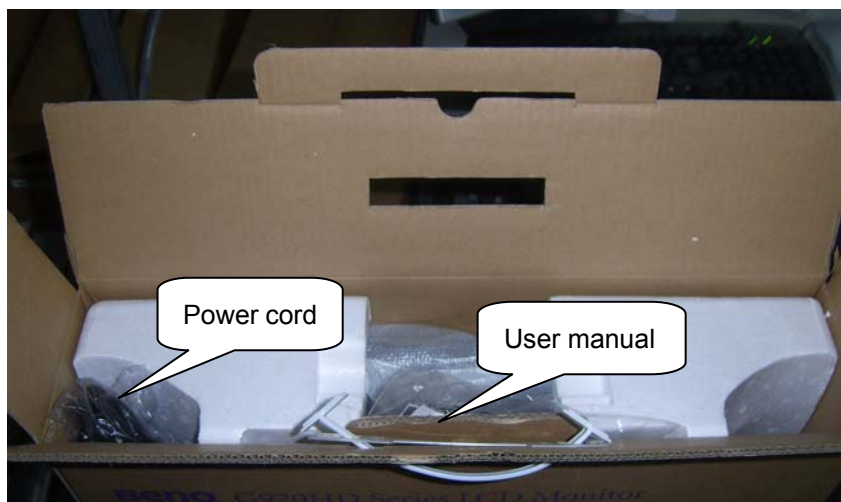

Putting the monitor and accessories into the carton

Level 1 Cosmetic / Appearance / Alignment Service

Visual Inspection & Cleaning

- Cleaning. Always unplug your monitor from the wall outlet before cleaning. Clean the LCD monitor surface with a lint-free, non-abrasive cloth. Avoid using any liquid, aerosol or glass cleaners.
- Slots and openings on the back or top of the cabinet are for ventilation. They must not be blocked or covered. Your monitor should never be placed near or over a radiator or heat source, or in a built-in installation unless proper ventilation is provided.
- Never push objects or spill liquid of any kind into this product.

Software/Firmware Upgrade Process

1. When do the part, need the tools as follow:

- a. An i486 (or above) personal computer or compatible.
- b. Microsoft operation system Windows 95/98/2000/XP.
- c. "PORT95NT.exe" program
- d. Software ISP SN Alignment kits

The kit contents:

- a. ISP BOARD x1
- b. Printer cable x1
- c. VGA cable x1

2. Install the "PORT95NT.exe", and restart the computer.

Note: After installation, you must restart the PC to take the setup to effect.

3. Connect the ISP board as follow:

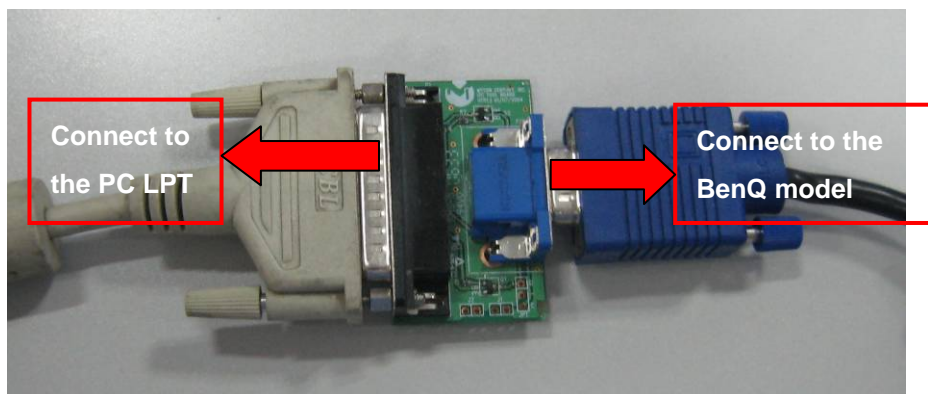



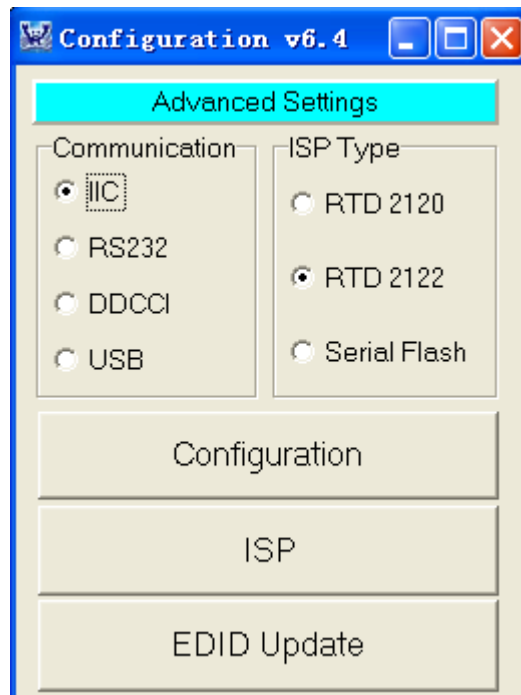

4. The process of ISP write is as follows.

a. Double-click  , running the program as follows:

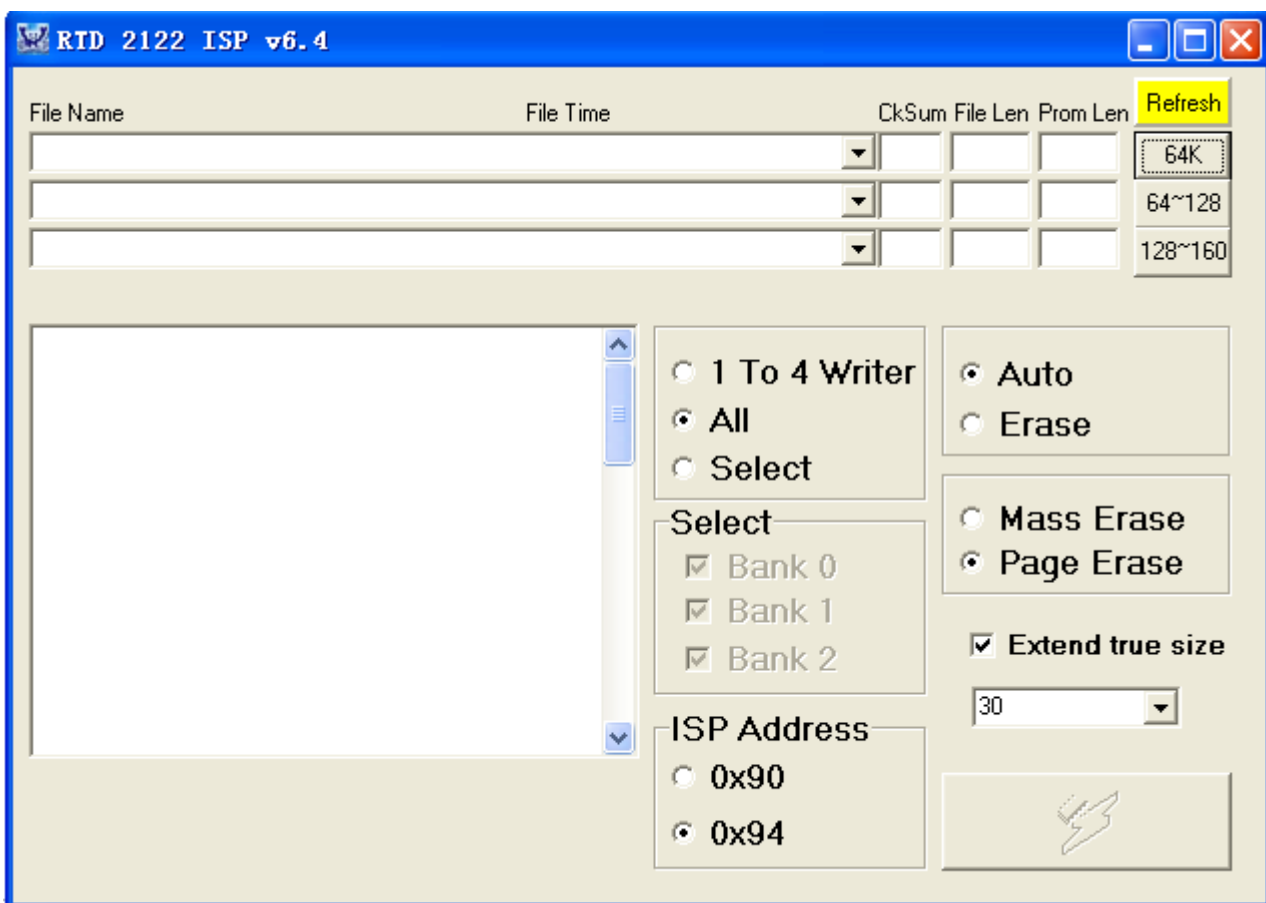

b. Choose **RTD 2122** , click **ISP** , running the program as follows:



- c. Click  icon, search the program" BenQ_G2020HDA_2045LH_SEC_V004.H00", and click **open**:
- d. Click  icon, search the program" BenQ_G2020HDA_2045LH_SEC_V004.H01", and click **open**:
- e. Click  icon, search the program" BenQ_G2020HDA_2045LH_SEC_V004_EXTEND", and click **open**:

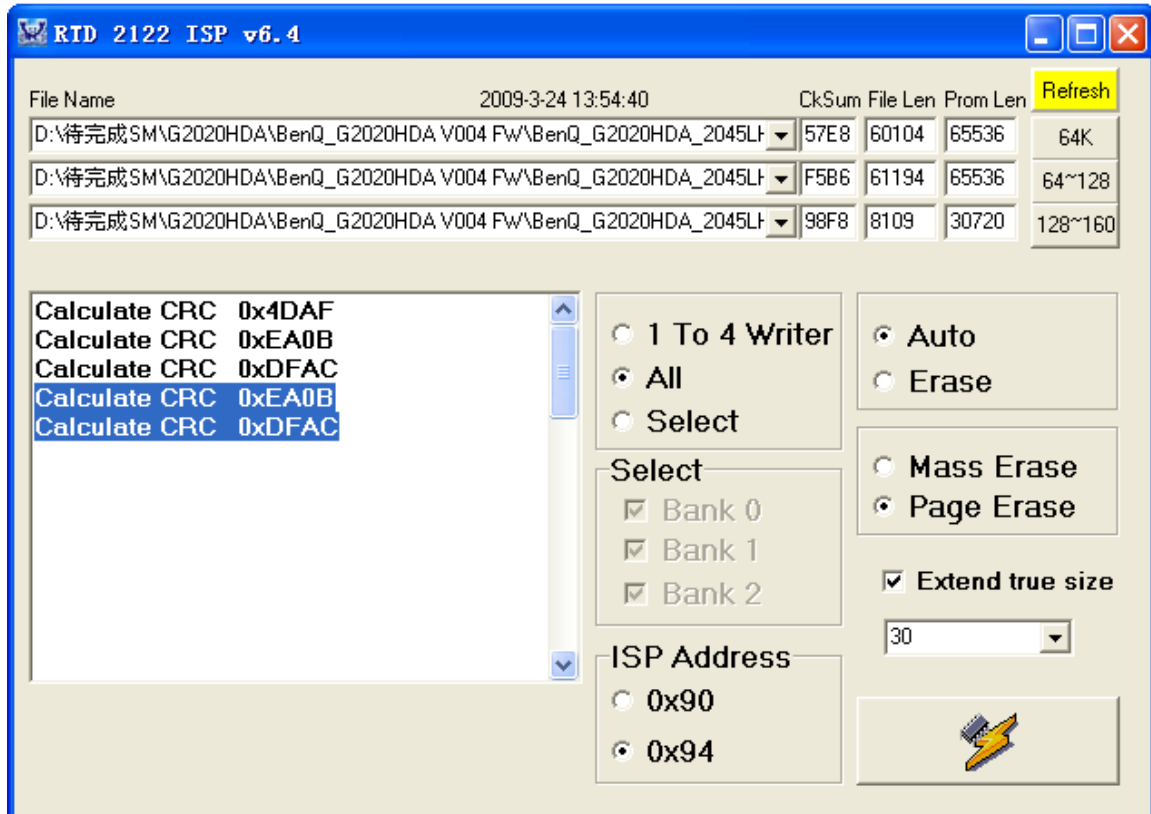

- f. Click  icon, until appear the follow Fig, writer completed.

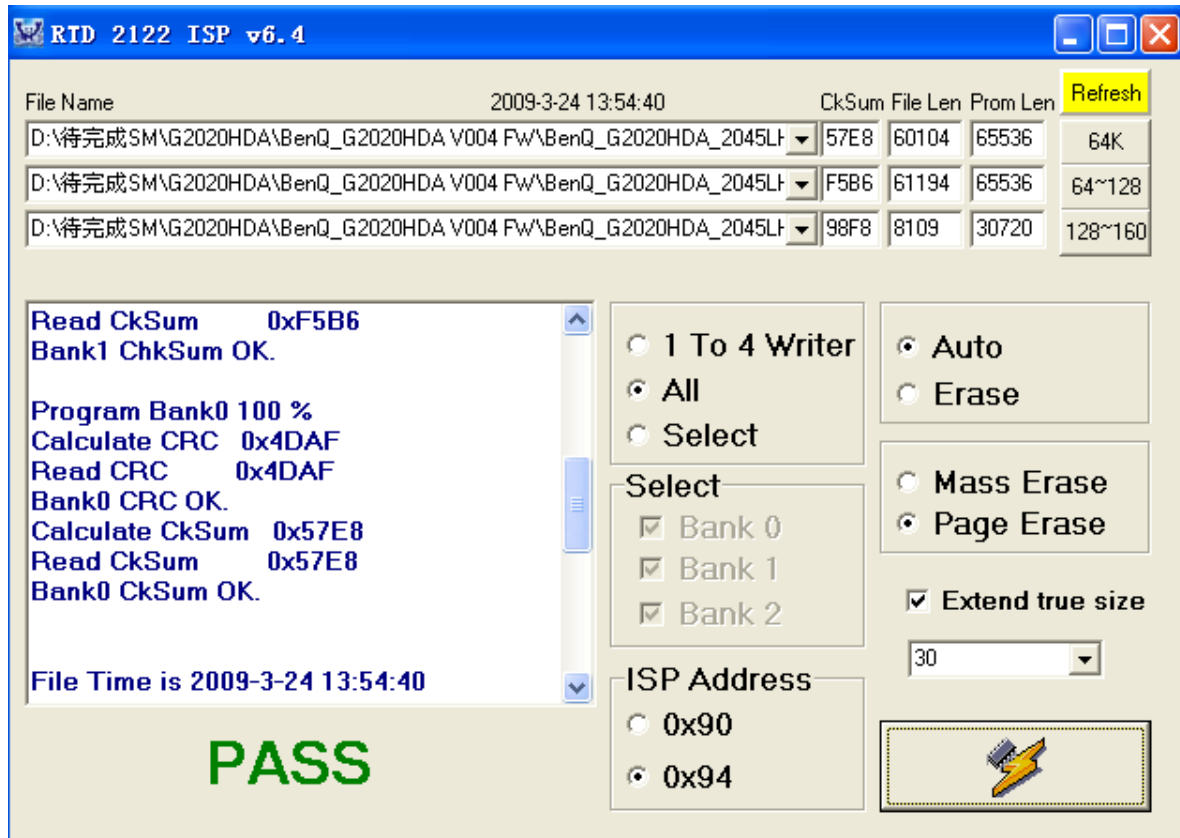

DDC instruction

General

DDC Data Re-programming

In case the main EEPROM with Software DDC which store all factory settings were replaced because a defect repaired monitor' the serial numbers have to be re-programmed.

It is advised to re- soldered the main EEPROM with Software DDC from the old board onto the new board if circuit board have been replaced, in this case the DDC data does not need to be re-programmed.

Additional information about DDC (Display Data Channel) may be obtained from Video Electronics Standards Association (VESA). Extended Display Identification Data (EDID) information may be also obtained from VESA.

1. When does the part, need the tools as follow:

- a. An i486 (or above) personal computer or compatible.
- b. Microsoft operation system Windows 95/98/2000/XP.
- c. "PORT95NT.exe, TPVDDC.exe" program.
- d. EDID BOARD (x1), Printer cable(x1), VGA cable (x1), Power cord (x 2), 12V DC power source.

2. Install the "PORT95NT.EXE", and restart the computer.

The process of installing "PORT95NT" has been specified in, so it will not be specified again. If you have any problem, please read it.

3. Connect the DDC Board as follow:

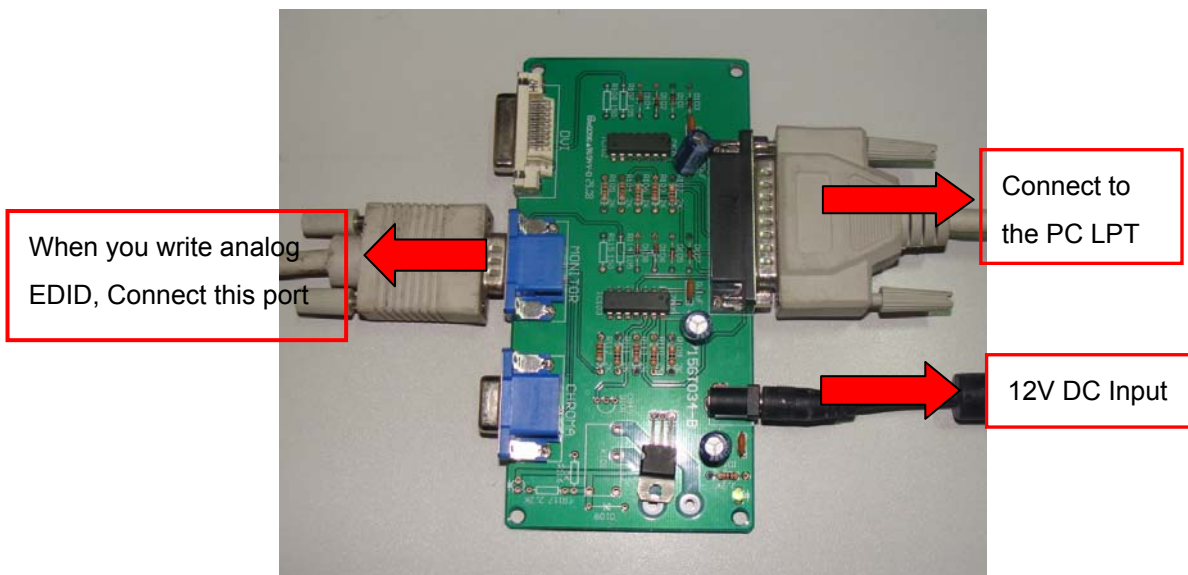

Note:

- 1. The monitor must be power on.
- 2. Turn off the monitor, keep pressing the "MENU" + "ENTER" buttons, and turn on the monitor, then when we press the AUTO button, the factory OSD will be at the left top of the panel as below, set the WP "Off ".

4. The process of ISP write is as follow:



a. Double-click  , appear as follow:

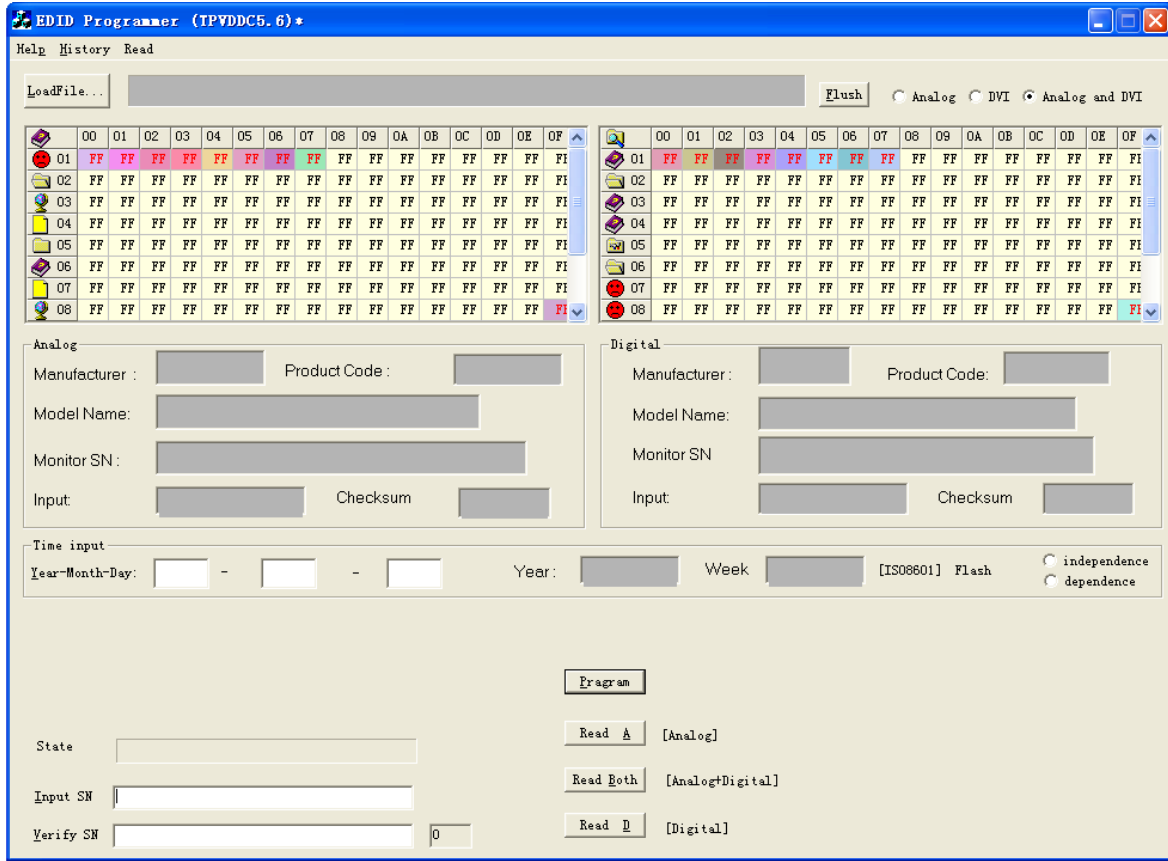

b. Choose "Analog " and then click "Loadfile", it will show the picture as follow:

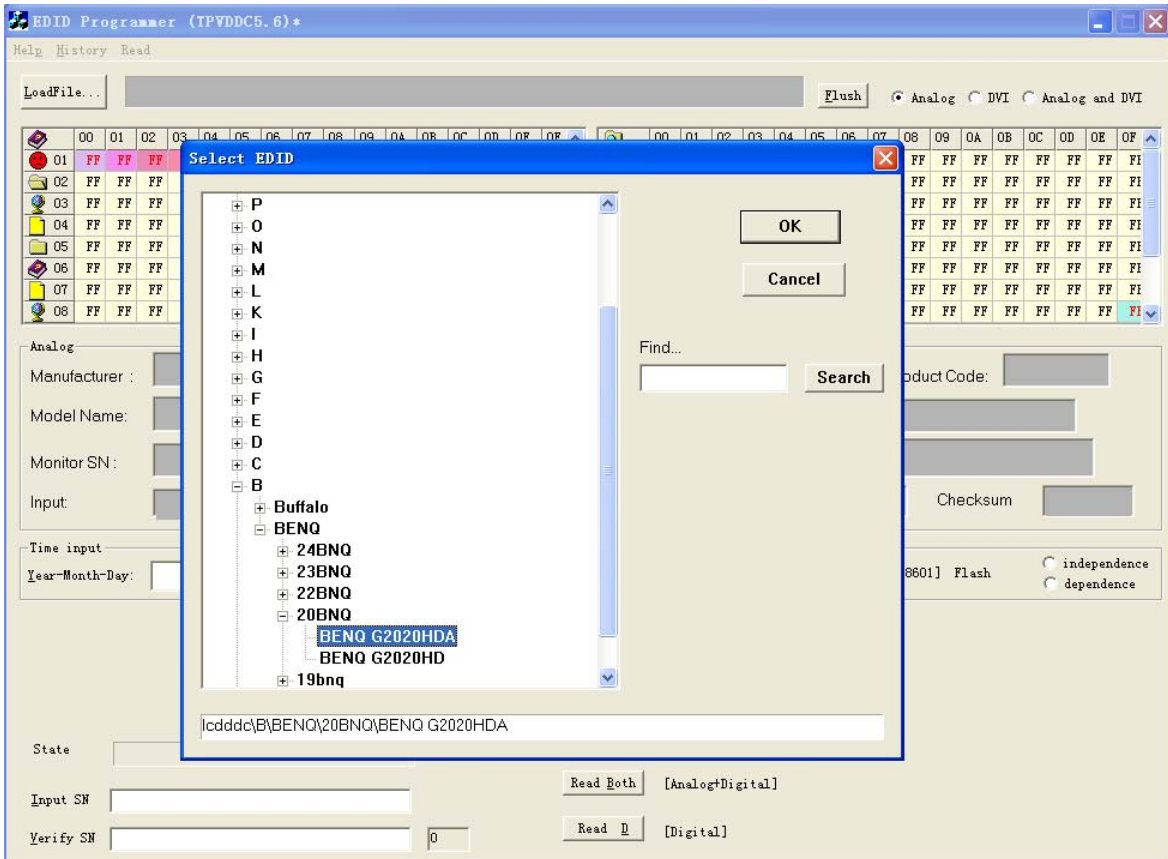

c. Click "OK", it will show the picture as follow:

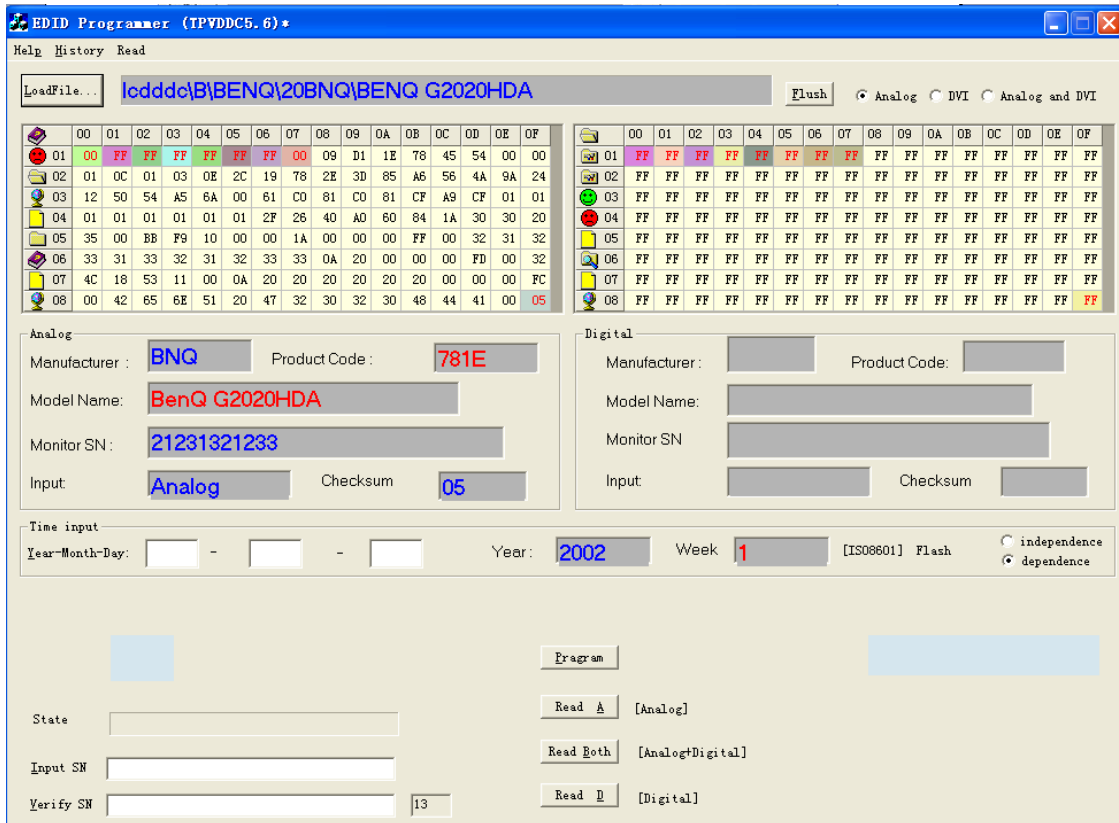

d. Input the date in "Year-Month-Day" box, Key in the same 13 numbers in the Input SN and Verify SN, then click "Program", when the analog DDC Write complete, it will show the picture as follow:

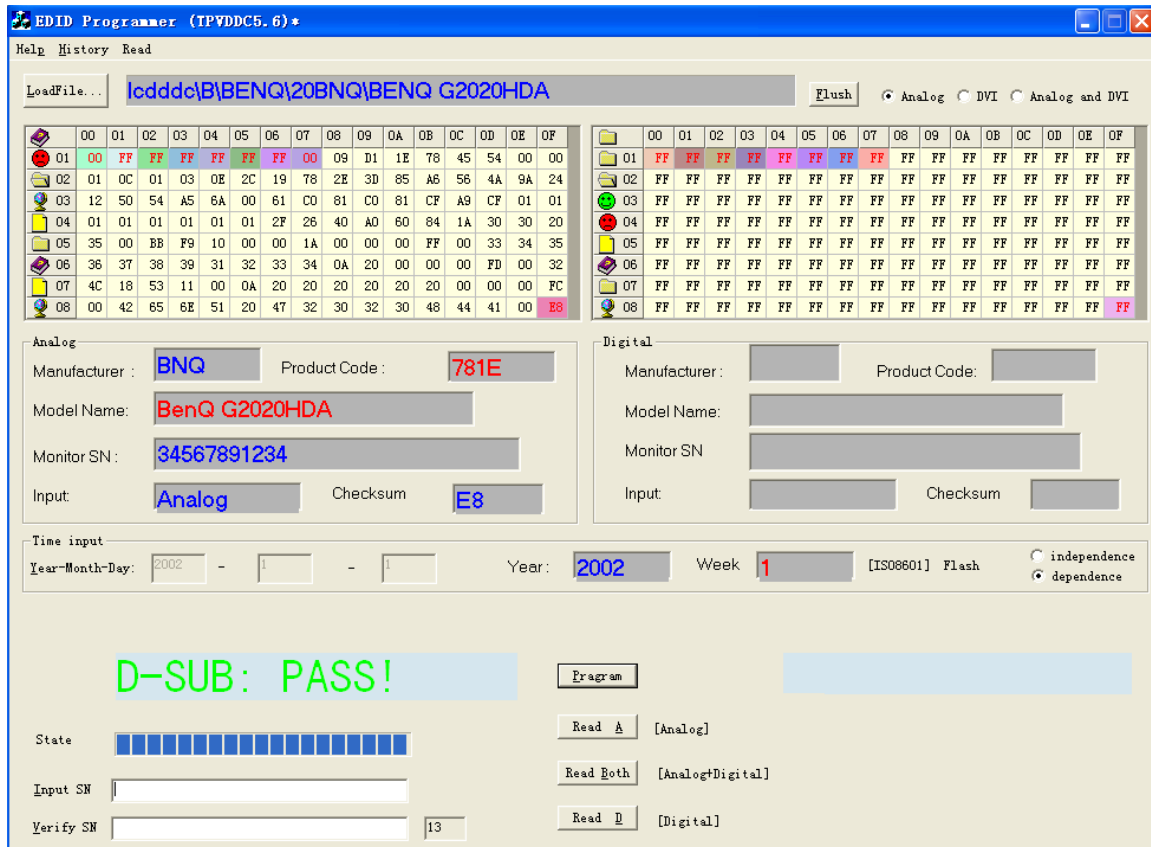

G2020HDA EDID

128 bytes EDID Data (Hex):

x0 x1 x2 x3 x4 x5 x6 x7 x8 x9 xA xB xC xD xE xF

```

0:  00 FF FF FF FF FF FF 00 09 D1 1E 78 45 54 00 00
10: 01 0C 01 03 0E 2C 19 78 2E 3D 85 A6 56 4A 9A 24
20: 12 50 54 A5 6A 00 61 C0 81 C0 81 CF A9 CF 01 01
30: 01 01 01 01 01 01 2F 26 40 A0 60 84 1A 30 30 20
40: 35 00 BB F9 10 00 00 1A 00 00 00 FF 00 32 31 32
50: 33 31 33 32 31 32 33 33 0A 20 00 00 00 FD 00 32
60: 4C 18 53 11 00 0A 20 20 20 20 20 20 00 00 00 FC
70: 00 42 65 6E 51 20 47 32 30 32 30 48 44 41 00 05

```

Decoded EDID data

<---Header--->

Header: 00 FF FF FF FF FF FF 00

<-x-Header-x->

<---Vendor/Product Identification--->

```

ID Manufacturer Name:  BNQ
ID Product Code:      781E
ID Serial Number:     45540000
Week of Manufacture:  1
Year of Manufacture:  2002

```

<-x-Vendor/Product Identification-x->

<---EDID Structure Version/Revision--->

```

EDID Version#:        01
EDID Revision#:       03

```

<-x-EDID Structure Version/Revision-x->

<---Basic Display Parameters/Features--->

```

Video i/p definition:  Analog
Signal Level Standard: 0.700V/0.300V (1.000Vpp)
Setup:                 Blank-to-Black not expected
Separate Sync Support: Yes

```

Composite Sync Support: Yes
 Sync. on green video supported: Yes
 Serration of the Vsync.Pulse is not required.
 Max. H. Image Size: 44cm.
 Max. V. Image Size: 25cm.
 Display Gamma: 2.2
 DPMS Features, Stand-by: No.
 DPMS Features, Suspend: No.
 DPMS Features, Active off: Yes.
 Display Type: R.G.B color display.
 Standard Default Color Space: Primary color space.
 Preferred Timing Mode: In First Detailed Timing.
 GTF supported: No.

<---Basic Display Parameters/Features--->

<---Color Characteristics--->

Red x: 0.6484375000
 Red y: 0.3388671875
 Green x: 0.2929687500
 Green y: 0.6025390625
 Blue x: 0.1425781250
 Blue y: 0.0703125000
 White x: 0.3125000000
 White y: 0.3291015625

<-x-Color Characteristics-x->

<---Established Timings--->

Established Timings 1: A5

-720x400 @70Hz VGA, IBM
 -640x480 @60Hz VGA, IBM
 -640x480 @75Hz VESA
 -800x600 @60Hz VESA

Established Timings 2: 6A

-800x600 @75Hz VESA
 -832x624 @75Hz Apple,Mac II
 -1024x768 @60Hz VESA
 -1024x768 @75Hz VESA

Established Timings 3: 00

<-x-Established Timings-x->

<---Standard Timing Identification--->

-1024x576@60 Hz

-1280x720@60 Hz

-1280x720@75 Hz

-1600x900@75 Hz

<-x-Standard Timing Identification-x->

<---Detailed Timing Descriptions--->

Detailed Timing: 1600x900 @ 60Hz

<-x-Detailed Timing Descriptions-x->

<---Detailed Timing Descriptions--->

Detailed Timing:FF (Monitor SN) '21231321233'

Detailed Timing:FD (Monitor limits)

Min. V. rate: 50Hz

Max. V. rate: 76Hz

Min. H. rate: 24 KHz

Max. H. rate: 83 KHz

Max. Pixel Clock: 170MHz

Detailed Timing: FC (Monitor Name) 'BenQ G2020HDA '

<-x-Detailed Timing Descriptions-x->

Extension Flag: 00

Checksum: 05

Adjustment / Alignment Procedure

Adjusting the Picture

You can use the OSD (On Screen Display) menu to adjust all the settings on your monitor.

Press the **MENU** key to display the following main OSD menu.

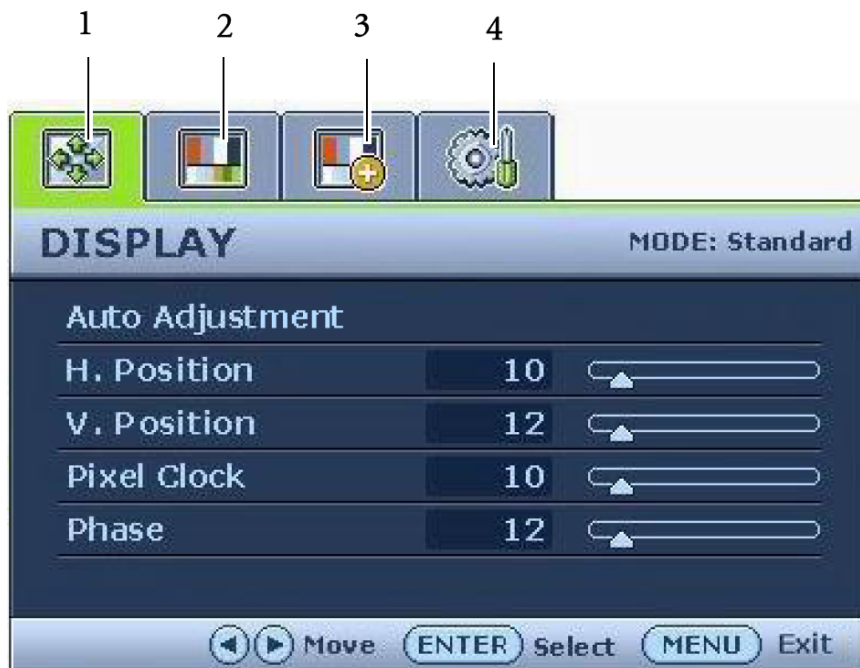

There are four main OSD menus:

1. Display
2. Picture
3. Picture Advanced
4. System

Use the ◀ or ▶ keys to highlight a menu item, and press the **ENTER** key to enter the Menu item settings. The OSD menu languages may differ from the product supplied to your region.

Display menu

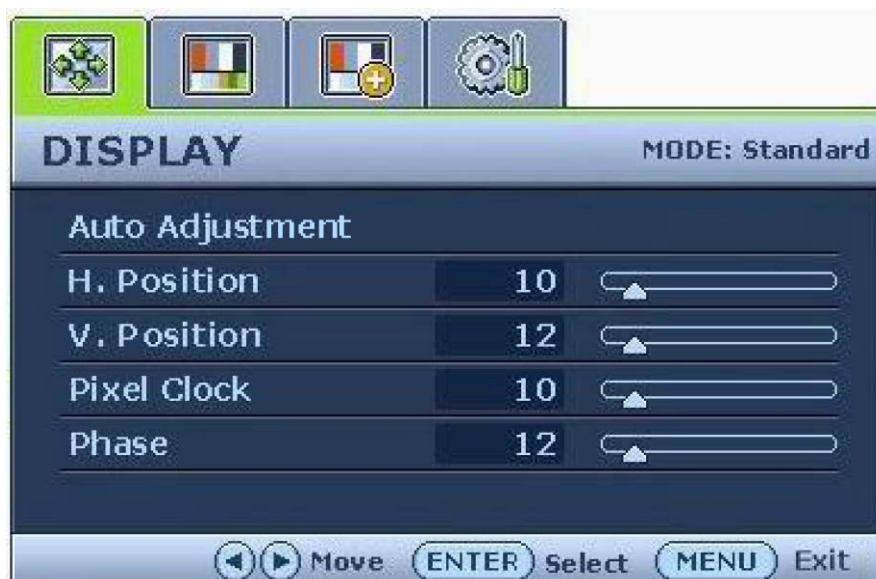

















1. Press the **MENU** key to display the main menu.
2. Press the ◀ or ▶ keys to select **DISPLAY** and then press the **ENTER** key to enter the menu.
3. Press the ◀ or ▶ keys to move the highlight to a menu item and then press the **ENTER** key to select that item.
4. Press the ◀ or ▶ keys to make adjustments or selections.
5. To return to the previous menu, press the **MENU** key.

Item	Function	Operation	Range
Auto Adjustment	Optimizes and adjusts the screen settings automatically for you. The AUTO key is a 'hot-key' for this function.  When you connect a digital video output using a digital (DVI) cable to your monitor, the AUTO key and the Auto Adjustment function will be disabled.	Press the ENTER key to select this option and make adjustment.	
H. Position	Adjusts the horizontal position of the screen image.	Press the ◀ or ▶ keys to adjust the value.	0 to 100
V. Position	Adjusts the vertical position of the screen image.		0 to 100
Pixel Clock	Adjusts the pixel clock frequency timing to synchronize with the analog input video signal. Not applicable to a digital input signal.		0 to 100
Phase	Adjusts the pixel clock phase timing to synchronize with the analog input video signal. Not applicable to a digital input signal.		0 to 63

Picture menu



1. Press the **MENU** key to display the main menu.
2. Press the ◀ or ▶ keys to select **PICTURE** and then press the **ENTER** key to enter the menu.
3. Press the ◀ or ▶ keys to move the highlight to a menu item and then press the **ENTER** key to select that item.
4. Press the ◀ or ▶ keys to make adjustments or selections.
5. To return to the previous menu, press the **MENU** button.

Item	Function	Operation	Range
Brightness	Adjusts the balance between light and dark shades.  The function is not available for use when Dynamic Contrast is on	Press the  key to increase the brightness and press the  key to decrease the brightness.	0 to 100
Contrast	Adjusts the degree of difference between darkness and lightness.  The function is not available for use when Dynamic Contrast is on.	Press the  key to increase the contrast and press the  key to decrease the contrast.	0 to 100
Sharpness	Adjusts the clarity and visibility of the edges of the subjects in the image.	Press the  key to improve the crispness of the display and press the  key to have softness effect on the display.	1 to 5
Color - Press ENTER to enter the Color menu.			
Normal	Allows video and still photographs to be viewed with natural coloring. This is the factory default color.	Press the  or  keys to select this option.	0 to 100
Bluish	Applies a cool tint to the image and is factory pre-set to the PC industry standard white color.		0 to 63
Reddish	Applies a warm tint to the image and is factory pre-set to the news print standard white color.		
User Mode	Tailors the image color tint. The blend of the Red, Green and Blue primary colors can be altered to change the color tint of the image. The default start setting is 50. Decreasing one or more of the colors will reduce their respective influence on the color tint of the image. e.g. if you reduce the Blue level the image will gradually take on a yellowish tint. If you reduce Green, the image will become a magenta tint.	Press the  or  keys and the ENTER key to select Red, Green, or Blue. Then use Press the  or  keys to make the color adjustments.	Red (0 to 100) Green (0 to 100) Blue (0 to 100)
Reset Color	Resets the User Mode custom color settings to the factory defaults.	Press the  or  keys to change the settings.	YES NO

Press **MENU** to leave the Color menu.

<p>Dynamic Contrast</p>	<p>The function will increase the level of contrast to provide sharper and more detailed image quality.</p> <p> Activating</p> <p>Dynamic Contrast will disable Brightness and Contrast controls.</p>	<p>Press the ENTER key to select this option. Press the ◀ or ▶ keys to change the settings.</p>	<p>0 to 5</p>
-------------------------	---	---	---------------

Picture advanced menu



1. Press the MENU key to display the main menu.
2. Press the ◀ or ▶ keys to select **PICTURE ADVANCED** and then press the ENTER key to enter the menu.
3. Press the ◀ or ▶ keys to move the highlight to a menu item and then press the ENTER key to select that item.
4. Press the ◀ or ▶ keys to make adjustments or selections.
5. To return to the previous menu, press the MENU button.



Item	Function	Operation	Range
<p>Picture Mode</p>	<p>Selects a picture mode that best suits the type of images shown on the screen.</p> <ul style="list-style-type: none"> • Standard - for basic PC application. • Movie - for viewing videos. • Dynamics - for viewing landscape-specific videos and playing games. • Photo - for viewing still images. • sRGB - for better color matching representation with the peripheral devices, such as printers, DSCs, etc. 	<p>Press the ◀ or ▶ keys to change the settings.</p>	<ul style="list-style-type: none"> • Standard • Movie • Dynamics • Photo • sRGB

<p>Senseye Demo (available when the Picture Mode is set to Photo, Dynamics, or Movie)</p>	<p>Displays the preview of screen images under the selected mode from the selected mode from Picture Mode. The screen will be divided into two windows; the left window demonstrates images of Standard mode, while the right window presents the images under the specified mode.</p>	<p>Press the ◀ or ▶ keys to change the settings.</p>	<ul style="list-style-type: none"> • ON • OFF
<p>Display Mode</p>	<p>This feature is provided to allow aspect ratio's other than 16:9 to be displayed without geometric distortion.</p> <ul style="list-style-type: none"> • Full - Scales the input image to fill the screen. Ideal for 16:9 aspect images. • Aspect - The input image is displayed without geometric distortion filling as much of the display as possible. <p> Aspect is not available when the video content is in a 16:9 aspect ratio.</p>	<p>Press the ◀ or ▶ keys to change the settings.</p>	<ul style="list-style-type: none"> • Full • Aspect

System menu



1. Press the MENU key to display the main menu.
2. Press the ◀ or ▶ keys to select **SYSTEM** and then press the ENTER key to enter the menu.
3. Press the ◀ or ▶ keys to move the highlight to a menu item and then press the ENTER key to select that item.
4. Press the ◀ or ▶ keys to make adjustments or selections.
5. To return to the previous menu, press the MENU button

Item	Function	Operation	Range
Input	Selects the D-sub (analog) input. Use this to change the input to that appropriate to your video cable connection type.  Analog-only models do not have the Input function.	Press the ◀ or ▶ keys to change the settings.	<ul style="list-style-type: none"> • D-sub • DVI
OSD Settings - Press ENTER to enter the OSD Settings menu.			
Language	Sets the OSD menu Language.	Press the ◀ or ▶ keys to change the settings.  The language options displayed on your OSD may differ from those shown on the right, depending on the product supplied in your region.	<ul style="list-style-type: none"> • English • French • German • Italian • Spanish • Polish/ Japanese • Czech/ Traditional Chinese • Hungarian/ Simplified Chinese • Serbo-Croatian • Romanian • Dutch • Russian • Swedish • Portuguese
H. Position	Adjusts the horizontal position of the OSD menu.	Press the ◀ or ▶ keys to change the settings.	0 to 100
V. Position	Adjusts the vertical position of the OSD menu.		0 to 100
Display Time	Adjusts the display the OSD menu.		<ul style="list-style-type: none"> • 5 Sec. • 10 Sec. • 15 Sec. • 20 Sec. • 25 Sec. • 30 Sec.

<p>OSD Lock</p>	<p>Prevents all the monitor settings from being accidentally changed. When this function is activated, the OSD controls and hotkey operations will be disabled.</p>	<p>Press the ◀ or ▶ keys to change the settings.</p> <p>🔒 To unlock the OSD controls when the OSD is preset to be locked, press and hold the "MENU" key for 15 seconds to enter the "OSD Lock" option and make changes.</p> <p>Alternatively, you may use the ◀ or ▶ keys to select "NO" in the "OSD Lock" submenu from the "OSD Settings" menu, and all OSD controls will be accessible.</p>	<ul style="list-style-type: none"> • YES • NO
<p>Press MENU to leave the OSD Settings menu.</p>			
<p>DDC/CI*</p>	<p>Allows the monitor settings to be set through the software on the PC.</p>	<p>Press the ENTER key to select this option.</p> <p>Press the ◀ or ▶ keys to change the settings.</p>	<ul style="list-style-type: none"> • ON • OFF
<p>Information</p>	<p>Displays the current monitor property settings.</p>	<p>Press the ENTER key to select this option.</p>	
<p>Reset All</p>	<p>Resets all mode, color and geometry settings to the factory default values.</p>	<p>Press the ◀ or ▶ keys to change the settings.</p>	<ul style="list-style-type: none"> • YES • NO

*DDC/CI, short for Display Data Channel/Command Interface, which was developed by Video Electronics Standards Association (VESA). DDC/CI capability allows monitor controls to be sent via the software for remote diagnostics.

Display timing table

Pixel Format	Hor.-f(kHz)	Hor. -p	Ver.-f (Hz)	Ver. -P	Pixel Clk (MHz)	Source
640 x 480	31.47	-	59.94	-	25.175	VGA
640 x 480	37.50	-	75.00	-	31.500	VGA
720 x 400	31.47	-	70.08	+	28.321	VGA
800 x 600	37.88	+	60.32	+	40.000	VESA
800 x 600	46.88	+	75.00	+	49.500	VESA
832 x 624	49.72	-	74.55	-	57.283	MAC
1024 x 768	48.36	-	60.00	-	65.000	VESA
1024 x 768	60.02	+	75.03	+	78.750	VESA
1152 X 864	67.50	+	75	+	108	VESA
1152 x 870	68.68	-	75.06	-	100.000	MAC
1152 x 900	61.80	±	65.96	±	92.978	SUN
1280 x 768	47.396	+	60.0	-	68.25	CVT
1280x800	49.702	-	59.81	+	83.5	CVT-8
1280x720	44.77	-	59.86	+	74.5	
1280 x 960	60.00	±	60.00	±	108.000	VESA
1280 x 1024	63.98	+	60.02	+	108.000	VESA
1280 x 1024	79.98	+	75.02	+	135.000	VESA
1360x768	47.70	+	60.01	+	85.5	VESA
1366x768	47.76	-	59.85	+	85.5	
1440 x 900	70.60	-	75	+	136.75	
1600 x 900	55.54	+	60	+	97.75	VESA

Factory OSD Menu

Turn off the monitor, keep pressing the "MENU" buttons, and turn on the monitor, then when we press the MENU button, the factory OSD will be at the left top of the panel as below.

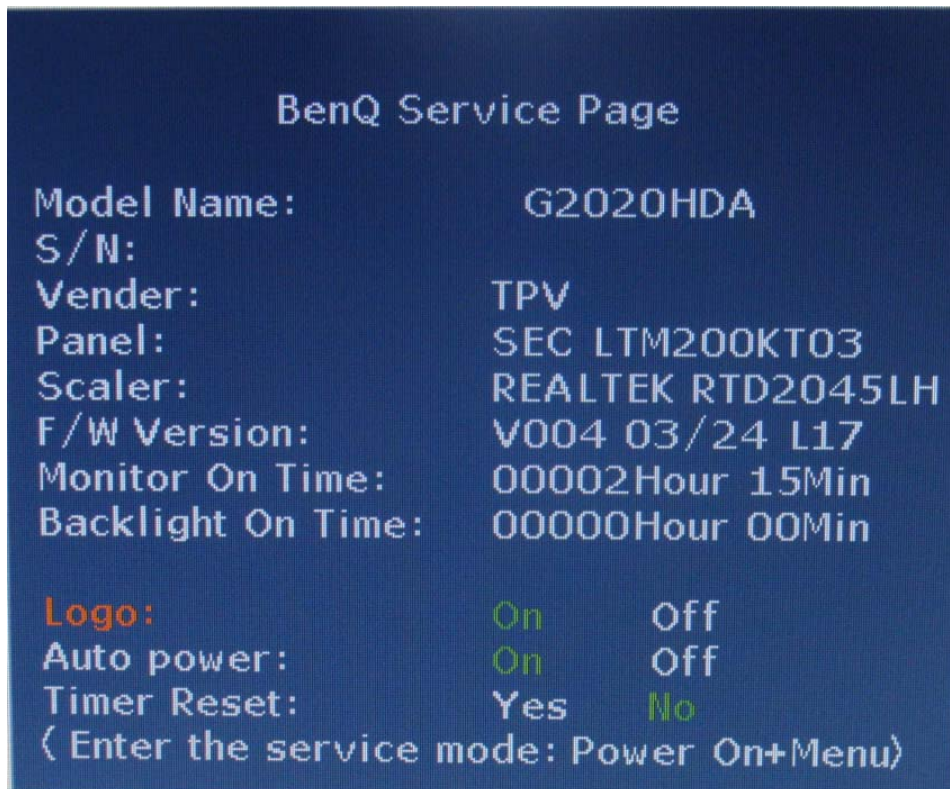
**BenQ Service Page**

1. Trigger method: Press "Menu" key and Power on.
2. Press the Menu key will display the service page
3. Press menu key will close the service page.
4. Power off will quit the service mode
5. At the service mode, the key function is same as normal OSD define.
6. The timer can only reset at the service mode by "Timer Reset". And need to have a warning message to double confirm the reset function. The timer should record up to 99999 hours
7. Add BenQ logo on/off item, the default is "on"
8. Add the auto power on item, the default is "off"
9. Add the timer reset warning message, when select the timer reset item, then the warning message will display and need to confirm it again and the default is "No".
10. Panel type define need to have the panel version
11. F/W version need to define the dual or analog model.

Level 2 Circuit Board and Standard Parts Replacement

Product Exploded View

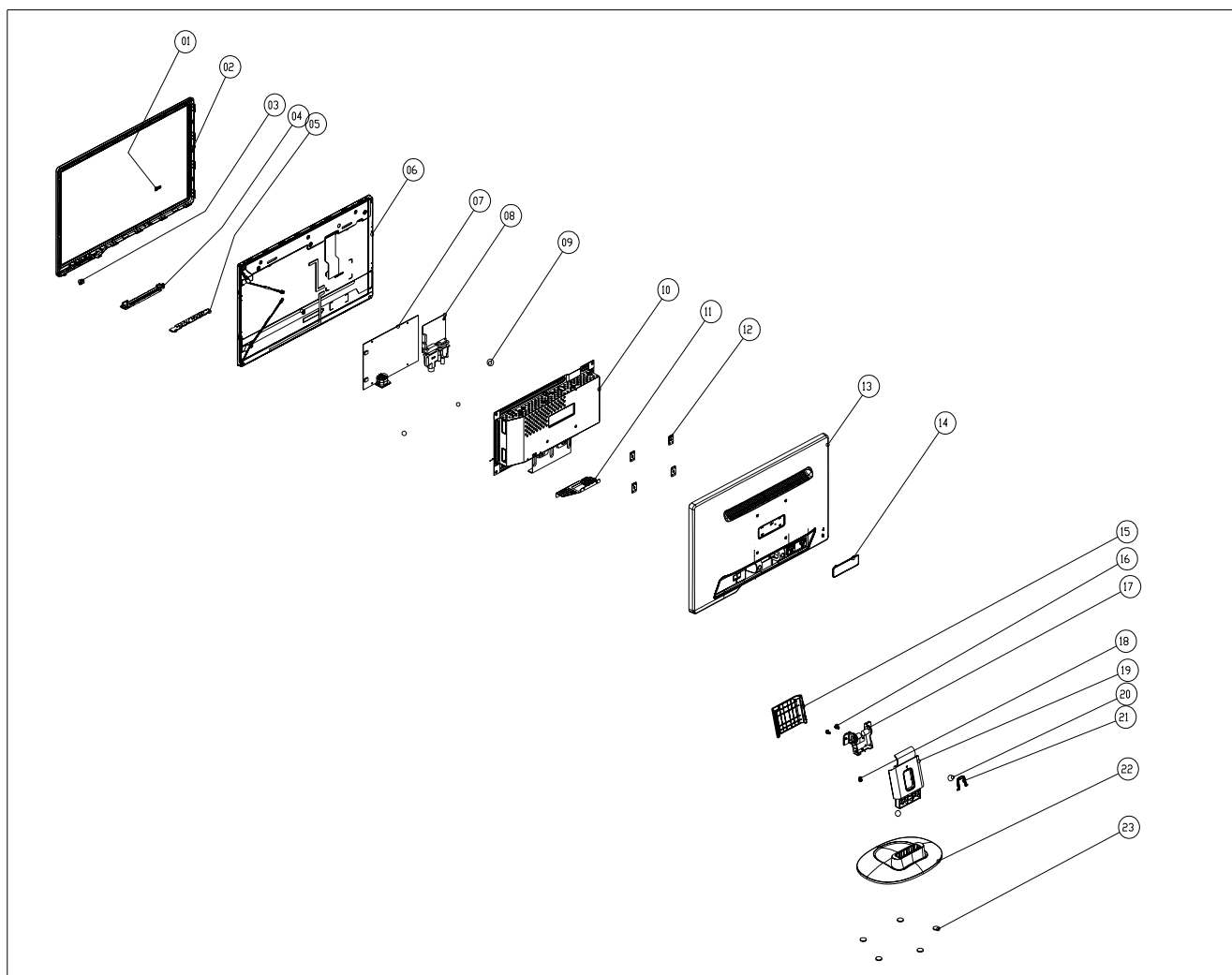

NO	PART NO	QTY	UNIT	DESCRIPTION	REMARK
1	Q23G3178881 1A	1	PCS	LOGO	
2	A34G1308ADPB1B0130	1	PCS	BEZEL 20"	
3	Q33G0288 2 1C0100	1	PCS	LENS	
4	Q33G0287ADP 1L0100	1	PCS	KEYPAD	
5	KEPC8QJ4	1	PCS	KEY BOARD	
6	750GLS200KT312N000	1	PCS	PANEL	
7	PWPC9A21VYD5	1	PCS	POWER BOARD	
8	756GQ9CB RK001	1	PCS	MAIN BOARD (CBPC9RKBFQD)	
9	0M1G1030 6120	5	PCS	SCREW M3X6	PB/MB &MAINFRAME
10	A15G0778 S1 4	1	PCS	MAINFRAME	

11	A85G0174101	1	PCS	AC SHIELD	
12	P15G8299 3	4	PCS	BKT-VESA	
13	A34G1309ADP 2B0130	1	PCS	REAR COVER 20"	
14	Q33G0289ADPA1L0100	1	PCS	LOGO COVER	
15	Q34G0545ADP 1B0100	1	PCS	STAND FRONT	
16	AQ1G1740 12120	2	PCS	SCREW	STAND & HINGE
17	Q37G0125021	1	PCS	HINGE	
18	0M1G1740 8 47 CR3	1	PCS	SCREW FOR GROUND 42-D000649	STAND & HINGE
19	Q34G0546ADP 1B0130	1	PCS	STAND_BACK	
20	AM1G1740 12 47 CR3	2	PCS	SCREW	HINGE & REAR COVER
21	A33G0251ADP 1L0100	1	PCS	CABLE CLIP	
22	Q34G0547ADP 1B0133	1	PCS	BASE	
23	Q12G6082 1	5	PCS	FOOT PAD	

Six angles' view

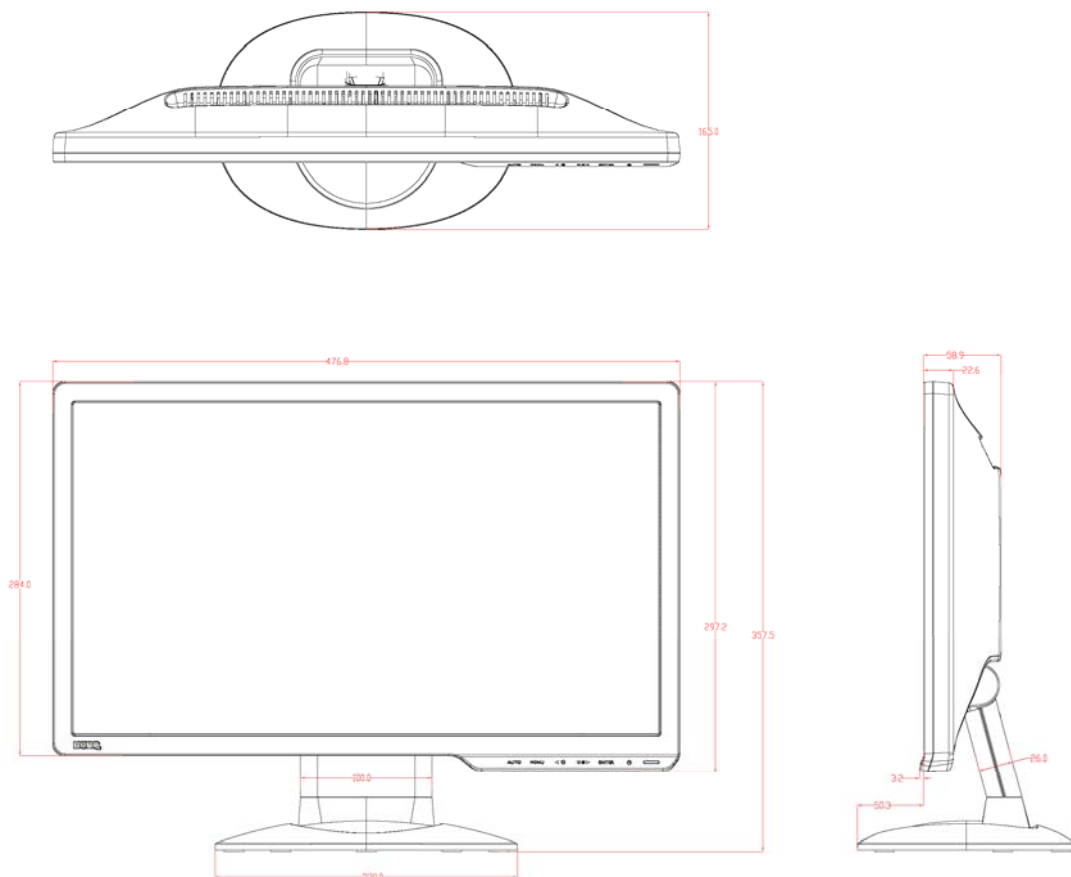

Product Disassembly**1). Remove the stand-base ASS'Y**

Place the monitor face down on a smooth surface. Be careful to avoid scratch and injury during the process of uninstall. And then remove the two screws as below to remove the stand-base ASS'Y.

**Fig1****2). Remove the Bezel**

Remove the bezel as follow:





3). Remove the rear cover



4). Remove the Panel

Disconnect the Lamp Connections and LVDS Cable connection.

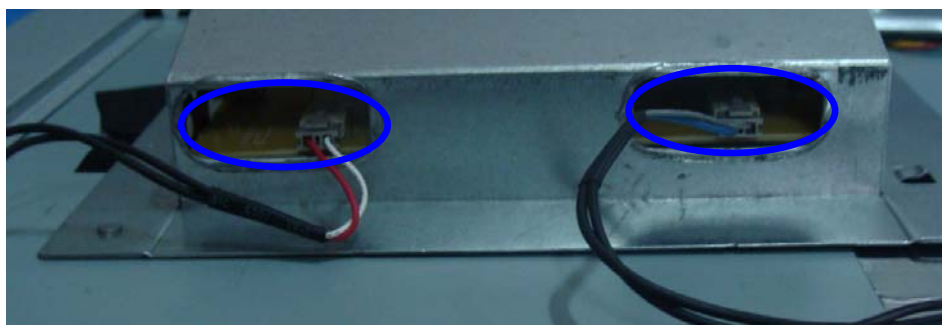

5).Remove the Main Board and Power Board

Remove the AC shielding, and remove the screws in red and disconnect the all connections in blue, at last you can get the Main Board and Power Board as follow.

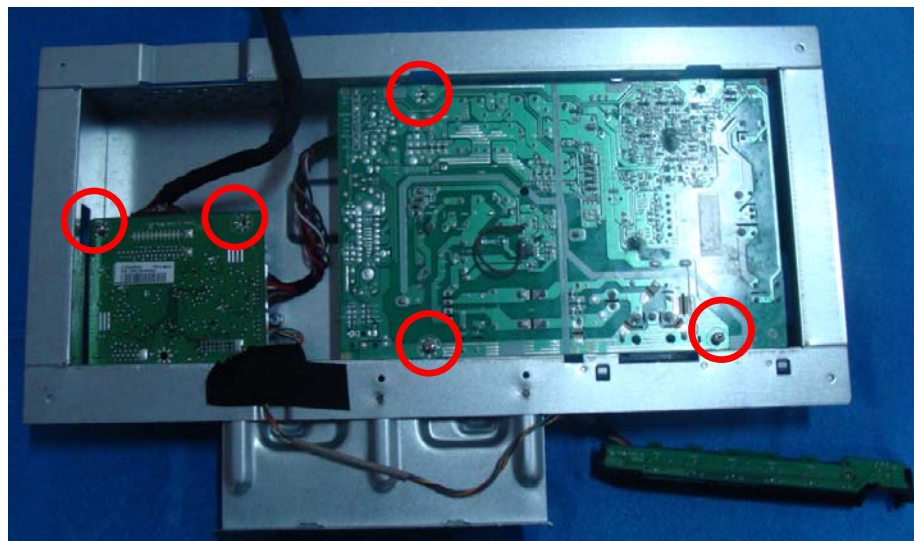

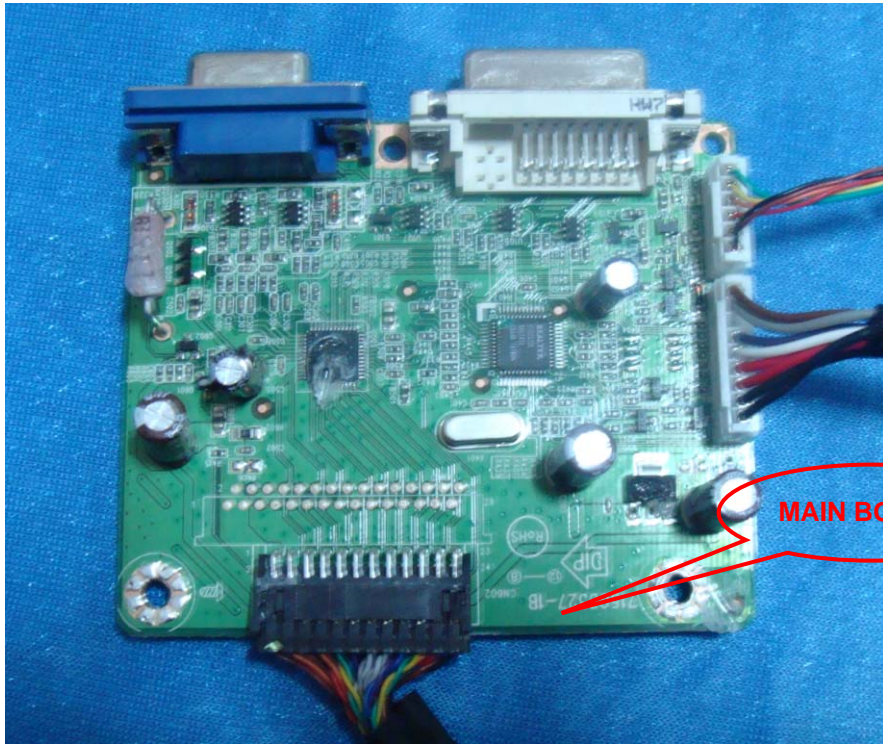

Block Diagram

Main Board

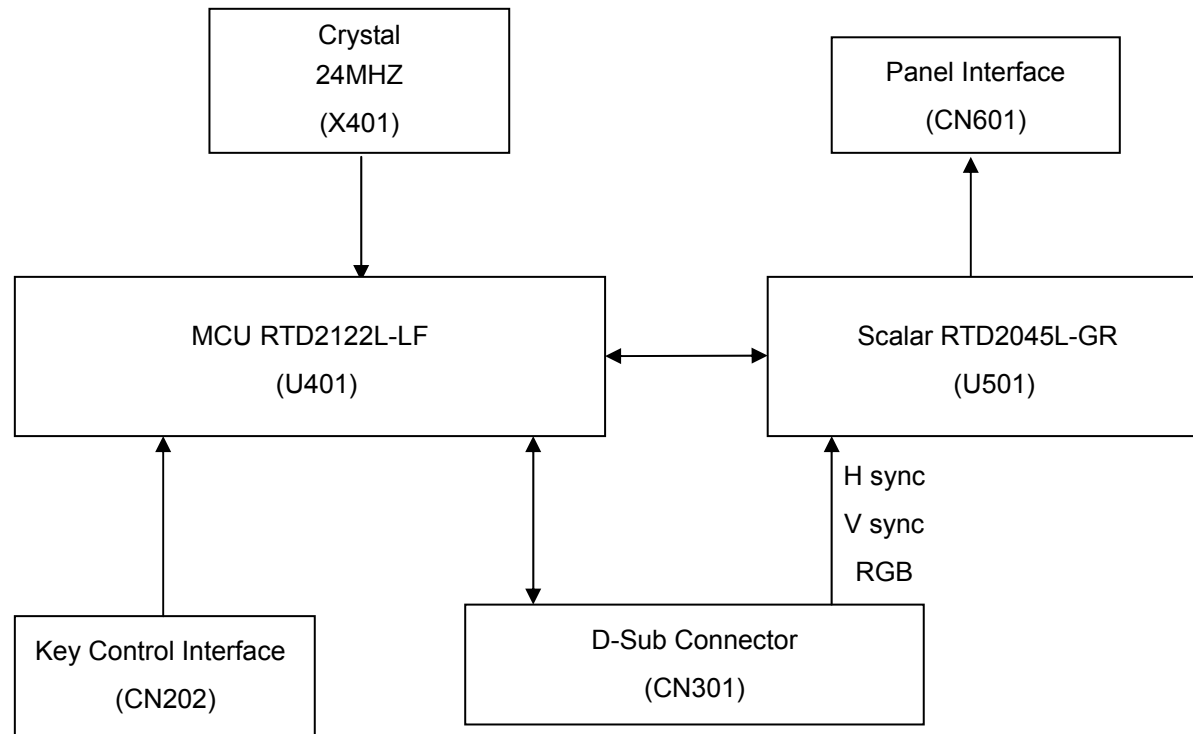

Power Board

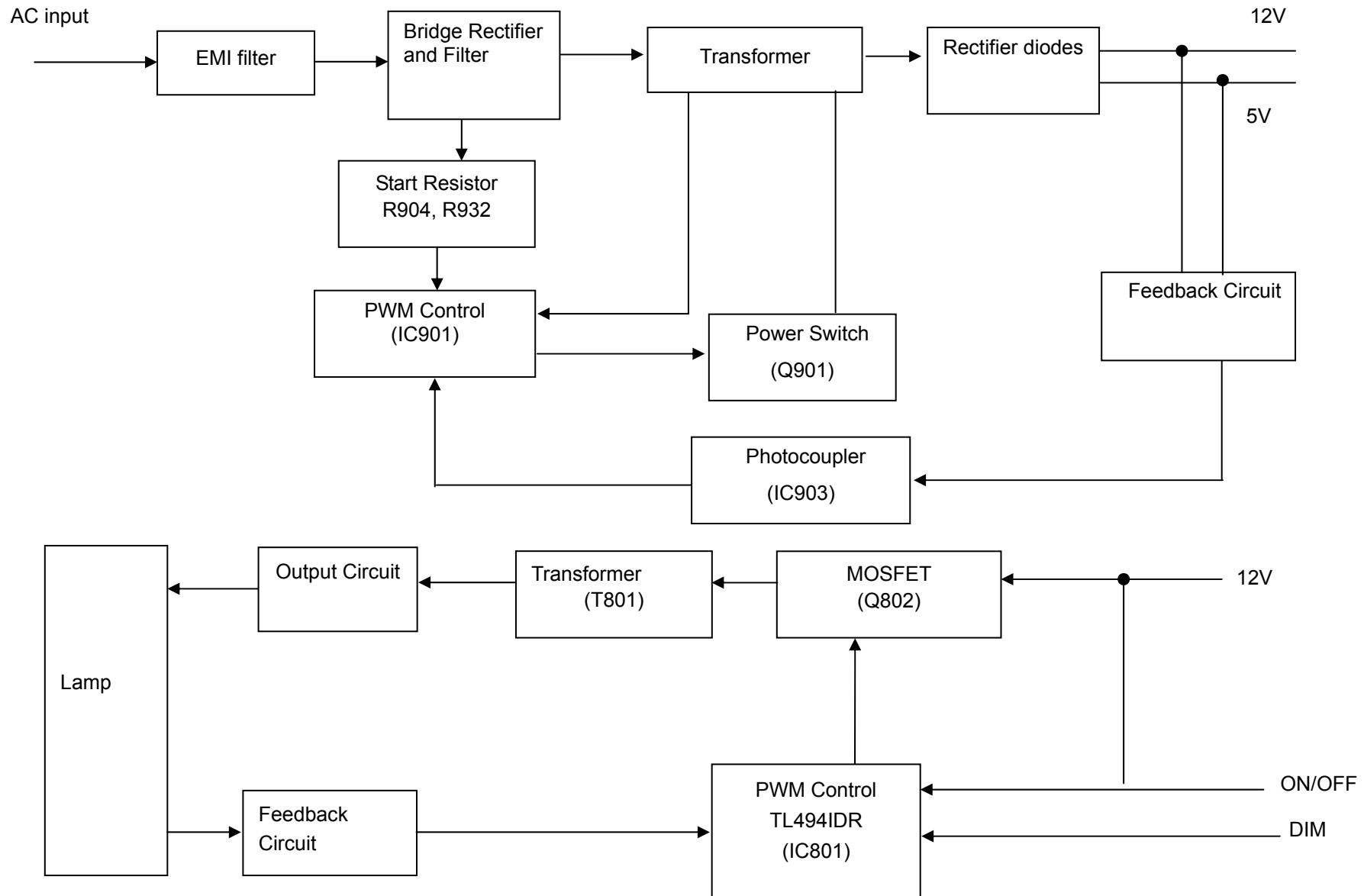

Schematic Diagram

Main Board

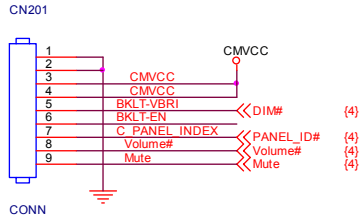

Panel ID(3.3V PWM)
Back light Dimming(3.3V PWM)

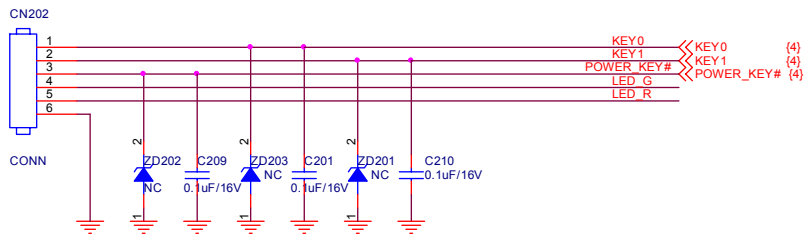
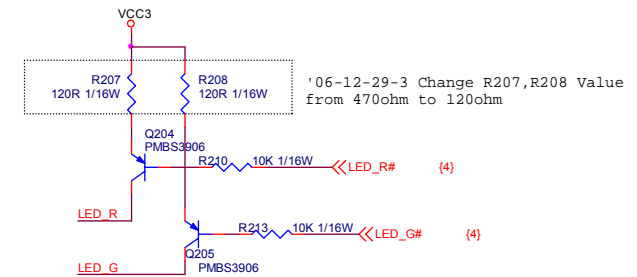
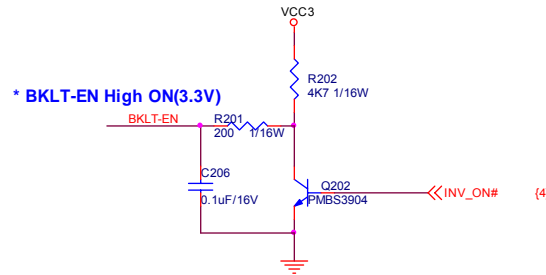
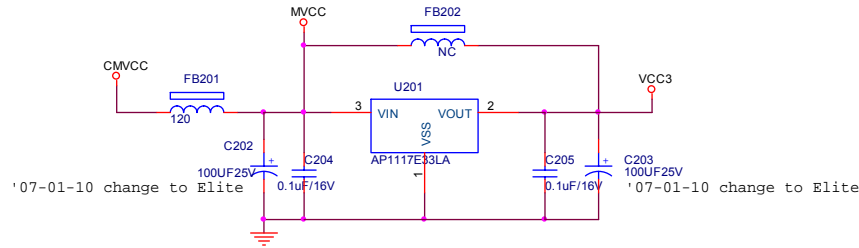

Near to Connect

TPV (Top Victory Electronics Co., Ltd.)	OEM MODEL	BenQ G2020HDA	Size	B	
話筒瓜擲	G2498-2A-AO-X-15-090209	TPV MODEL	TA9SRKN8FWBQNN	Rev	1.0
Key Component	3.POWER	PCB NAME	715G2498-2A-AO	修簽	<修簽>
Date	Monday, February 09, 2009	Sheet	3 of 7		

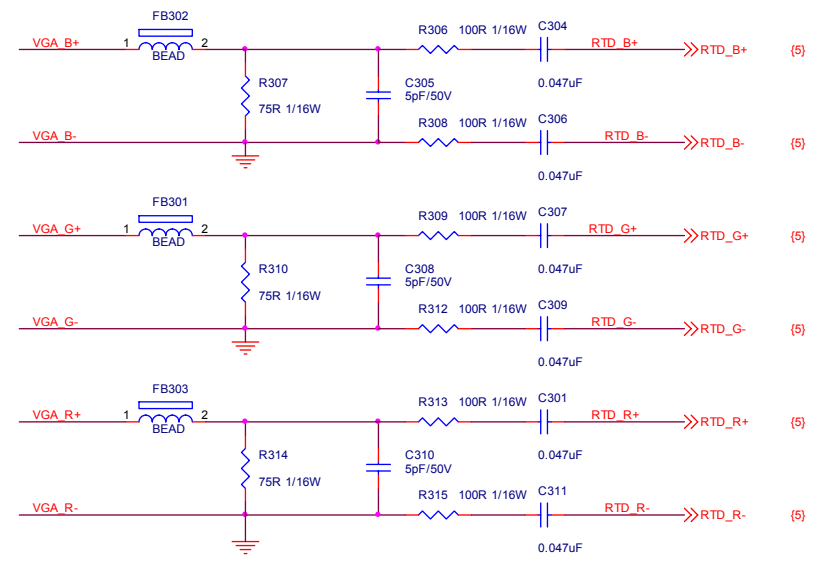
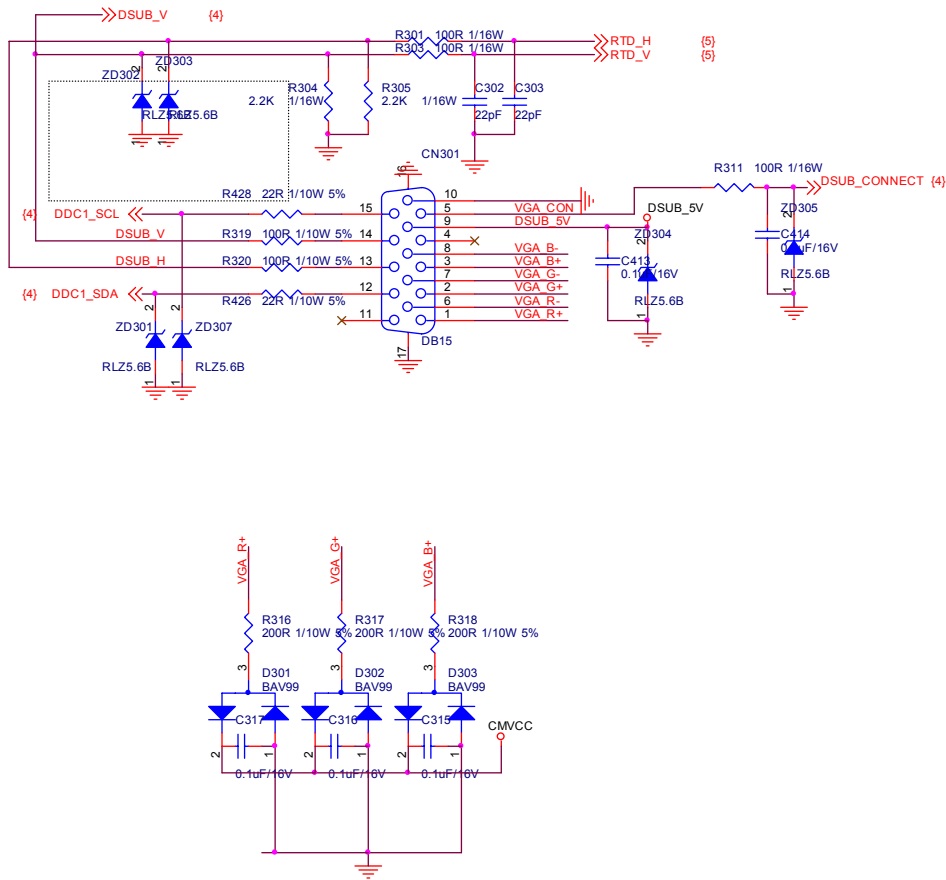

TPV (Top Victory Electronics Co., Ltd.)	OEM MODEL	BenQ G2020HDA	Size	B
结商瓜瓣版 G2498-2A-AO-X-15-090209	TPV MODEL	TA9SRKN8FWBQNN	Rev	1.0
Key Component 4.INPUT	PCB NAME	715G2498-2A-AO	陈豪	<陈豪>
Date Monday, February 09, 2009	Sheet	4 of 7		

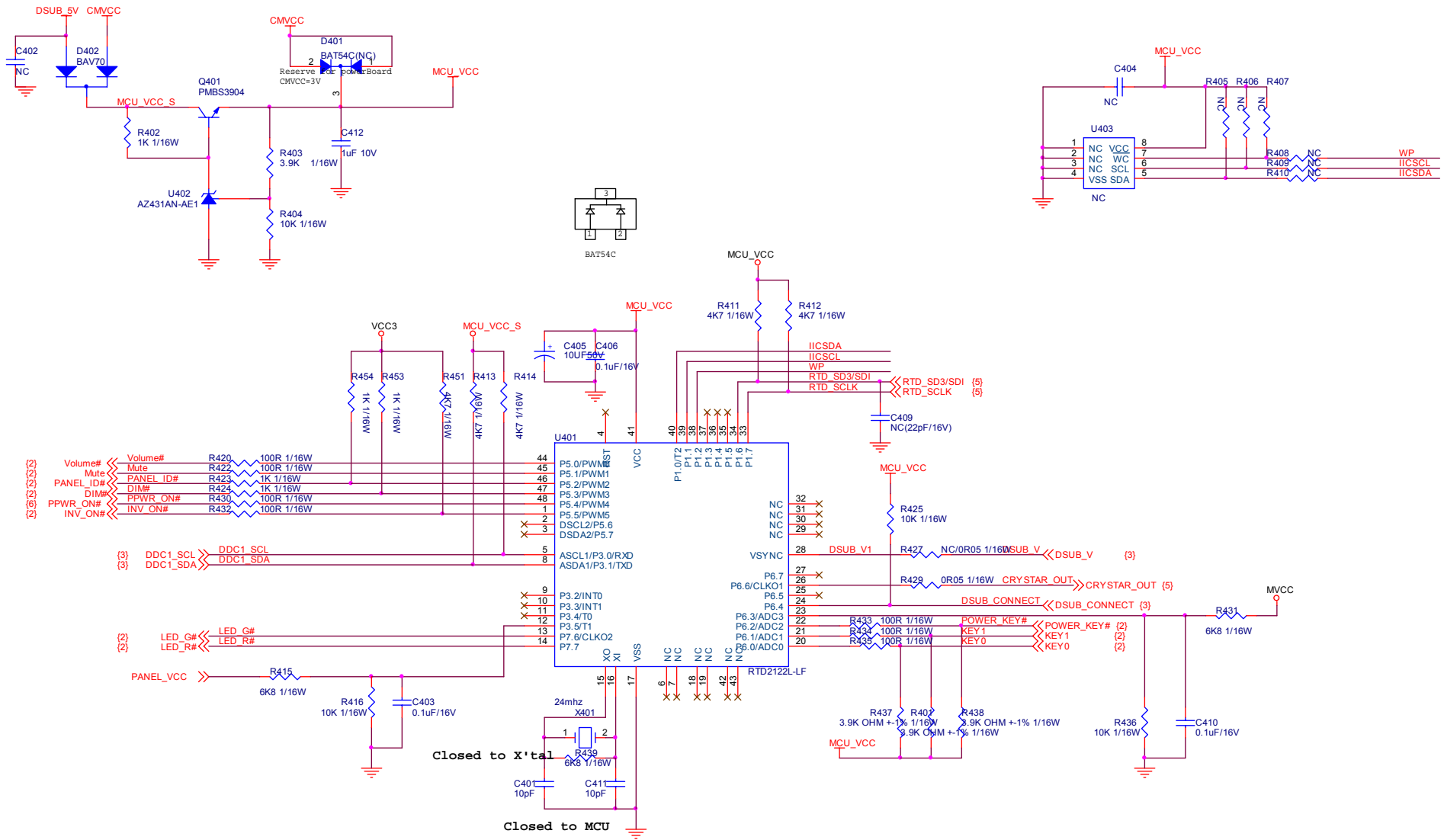

TPV (Top Victory Electronics Co., Ltd.)	OEM MODEL	BenQ G2020HDA	Size	B
話筒瓜網廠	G2498-2A-AO-X-15-090209	TPV MODEL	TA9SRKN8FWBQNN	Rev
Key Component	5.MCU/RTD2122	PCB NAME	715G2498-2A-AO	修簽
Date	Monday, February 09, 2009	Sheet	5 of 7	<修簽>

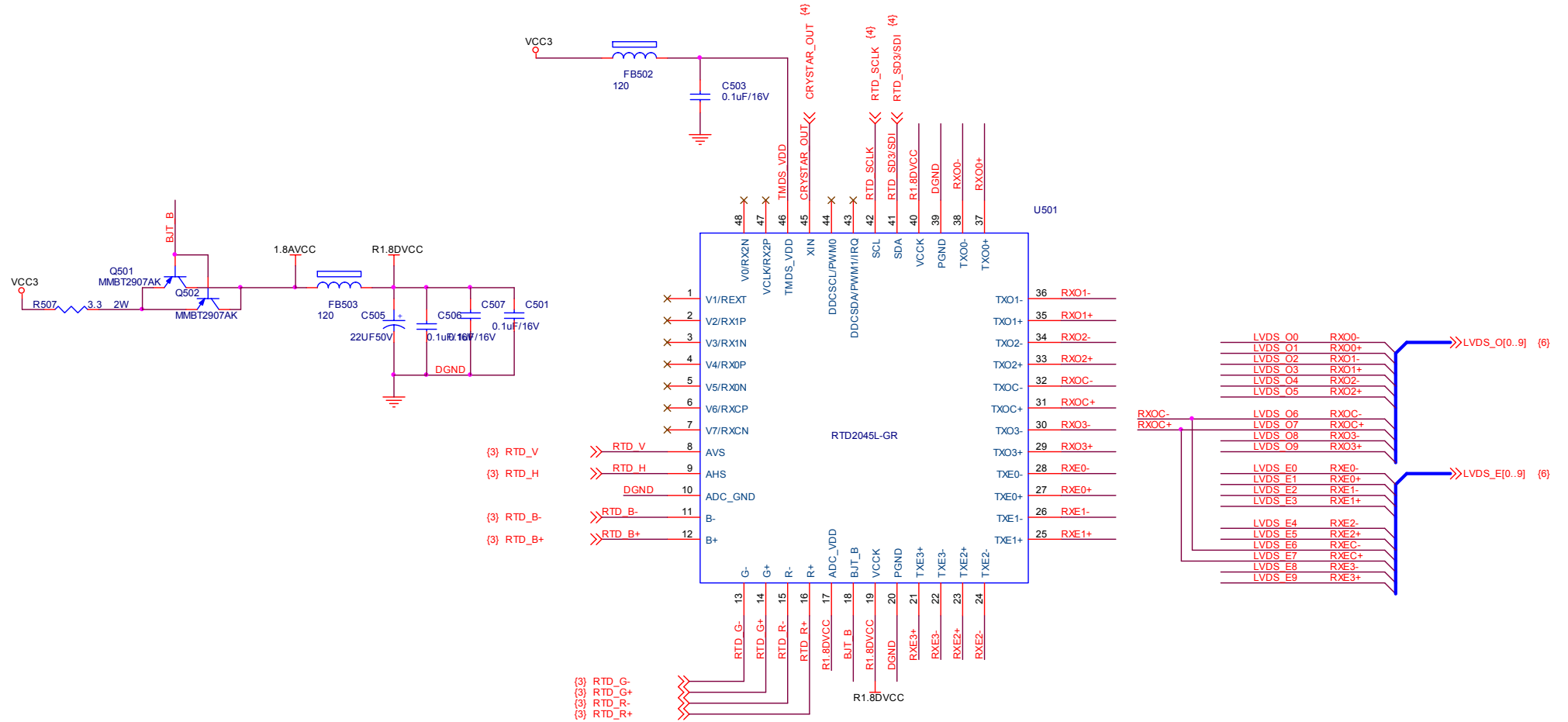

TPV (Top Victory Electronics Co., Ltd.)	OEM MODEL	BenQ G2020HDA	Size	B
紙隔爪網膜	G2498-2A-AO-X-15-090209	TPV MODEL	TA9SRKN8FWBQNN	Rev 1.0
Key Component	6.RTD2035L	PCB NAME	715G2498-2A-AO	称差 <称差>
Date	Monday, February 09, 2009	Sheet	6 of 7	

LVDS Panel (Normal Type)

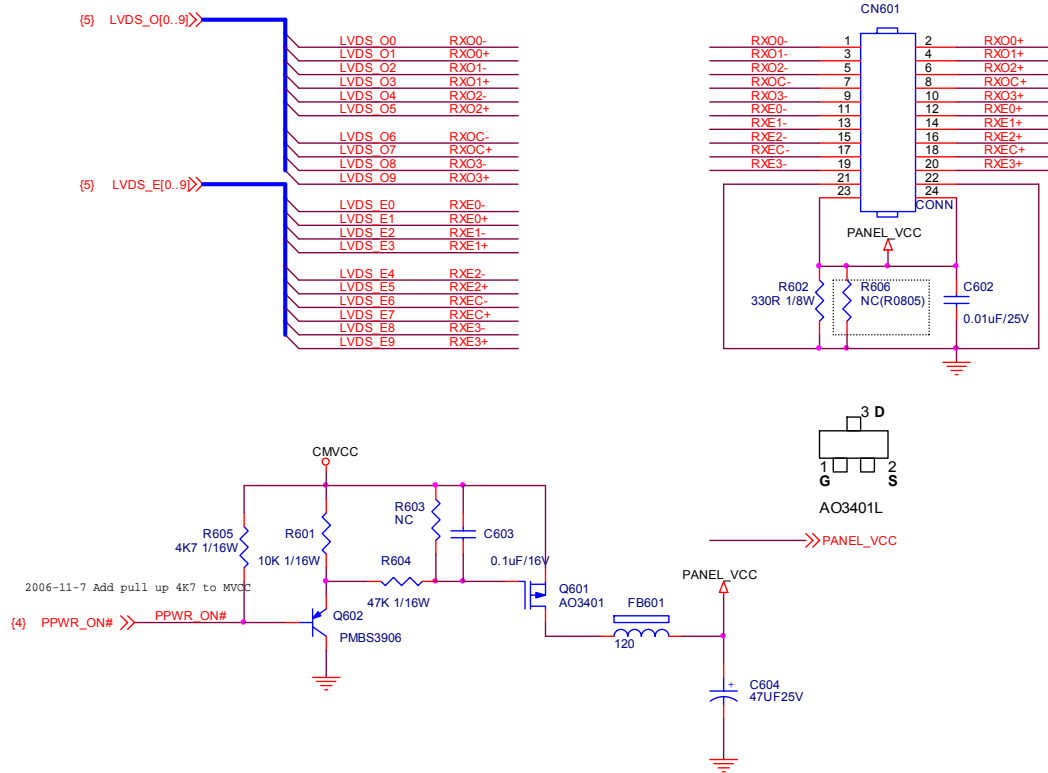

TPV (Top Victory Electronics Co., Ltd.)	OEM MODEL	BenQ G2020HDA	Size	A	
話隔瓜網廠	G2498-2A-AO-X-15-090209	TPV MODEL	TA9SRKN8FWBQNN	Rev	1.0
Key Component	7_OUTPUT	PCB NAME	715G2498-2A-AO	稱參	<稱參>
Date	Monday, February 09, 2009	Sheet	7 of 7		

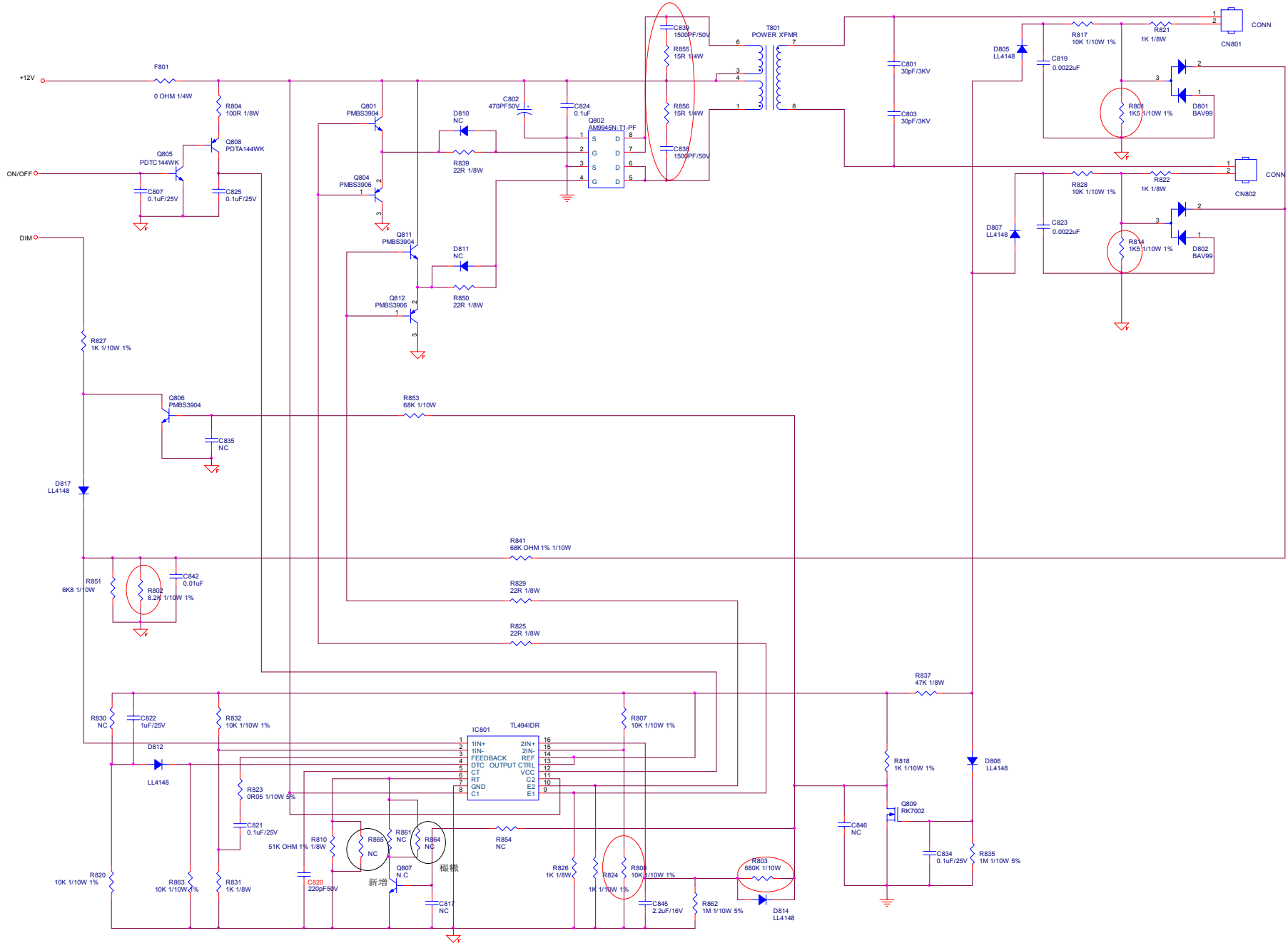

Key Board

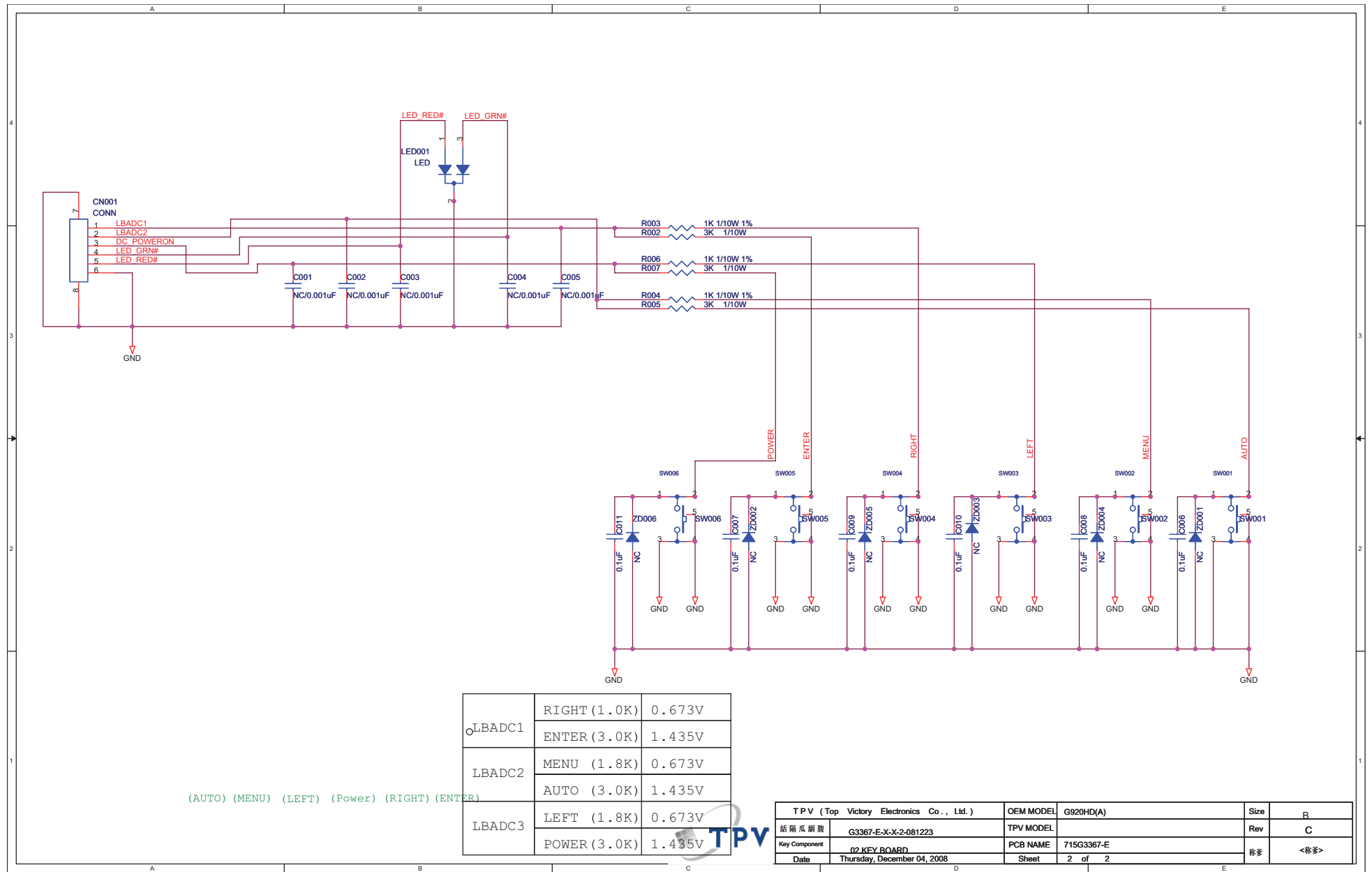

Troubleshooting Guide

Equipments and Tools Requirement

1. Voltmeter.
2. Oscilloscope.
3. Pattern Generator.
4. DDC Tool with and Compatible Computer.
5. Alignment Tool.
6. LCD Color Analyzer.
7. Service Manual.
8. User Manual.

Frequently asked questions (FAQ)

① The image is blurred:

☞ Read the instructions on the link "**Adjusting the Screen Resolution**" on the CD, and then select the correct resolution, refresh rate and make adjustments based on these instructions.

☞ How do you use a VGA extension cable?

Remove the extension cable for the test. Is the image now in focus? If not, optimize the image by working through the instructions in the "**Adjusting the refresh rate**" section on the link "**Adjusting the Screen Resolution**". It is normal for blurring to occur due to conduction losses in extension cables. You can minimize these losses by using an extension cable with better conduction quality or with a built-in booster.

☞ Does the blurring only occur at resolutions lower than the native (maximum) resolution?

Read the instructions on the link "**Adjusting the Screen Resolution**" on the CD. Select the native resolution.

① Pixel errors can be seen:

☞ One of several pixels is permanently black, one or more pixels are permanently white, one or more pixels are permanently red, green, blue or another color.

- Clean the LCD screen.
- Cycle power on-off.

These pixels are permanently on or off and that is a natural defect that occurs in LCD technology.

① The image has a faulty coloration:

☞ It has a yellow, blue or pink appearance.

Select MENU > PICTURE > Color > Reset Color, and then choose "YES" in the "Caution" message box to reset the color settings to the factory defaults.

If the image is still not correct and the OSD also has faulty coloration, this means one of the three primary colors is missing in the signal input. Now check the signal cable connectors. If any pin is bent or broken off, please contact your dealer to get necessary support.

① No image can be seen:

☞ Is the prompt on the display illuminated in green?

If the LED is illuminated in green and there is a message "Out of Range" on the screen, this means you are using a display mode that this monitor does not support, please change the setting to one of the supported mode. Please read the "**Preset display modes**" section from the link "**Adjusting the Screen Resolution**".

- ① Faint shadow from the static image displayed is visible on the screen:
- Activate the power management function to let your computer and monitor go into a low power "sleep" mode when not actively in use.
 - Use a screensaver to prevent the occurrence of image retention.
- ② Is the prompt on the display illuminated in orange?
- If the LED is illuminated in orange, the power management mode is active. Press any button on the computer keyboard or move the mouse. If that does not help, check the signal cable connectors. If any pin is bent or broken off, please contact your dealer to get necessary support.
- 🗨️ Is the prompt on the display not illuminated at all?
- Check the power supply mains socket, the external power supply and the mains switch.
- ③ The image is distorted, flashes or flickers:
- 🗨️ Read the instructions on the link "**Adjusting the Screen Resolution**" on the CD, and then select the correct resolution, refresh rate and make adjustments based on these instructions.
- 🗨️ You are running the monitor at its native resolution, but the image is still distorted.
- Images from different input sources may appear distorted or stretched on the monitor running at its native resolution. To have the optimal display performance of each type of input sources, you can use the "Display Mode" function to set a proper aspect ratio for the input sources.
- ④ The image is displaced in one direction:
- 🗨️ Read the instructions on the link "**Adjusting the Screen Resolution**" on the CD, and then select the correct resolution, refresh rate and make adjustments based on these instructions.
- ⑤ The OSD controls are inaccessible:
- To unlock the OSD controls when the OSD is preset to be locked, press and hold the "MENU" key for 15 seconds to enter the "OSD Lock" option and make changes.
 - Alternatively, you may use the ◀ or ▶ keys to select "NO" in the "OSD Lock" submenu from the "OSD Settings" menu (under SYSTEM), and all OSD controls will be accessible.

If your problems remain after checking this manual, please contact your place of purchase or e-mail us at:

Support@BenQ.com

Main Board

(1) No Power

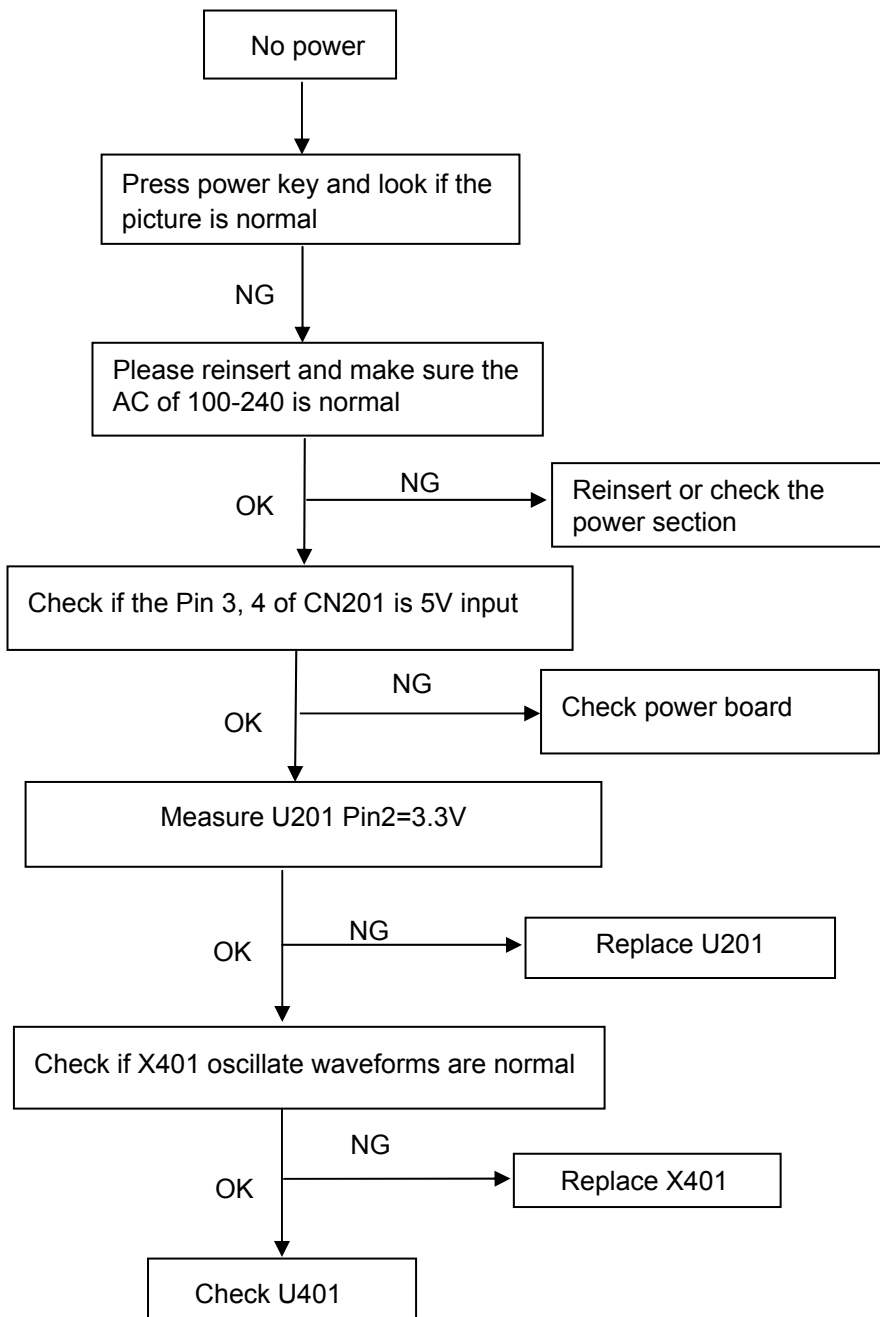

(2) No picture

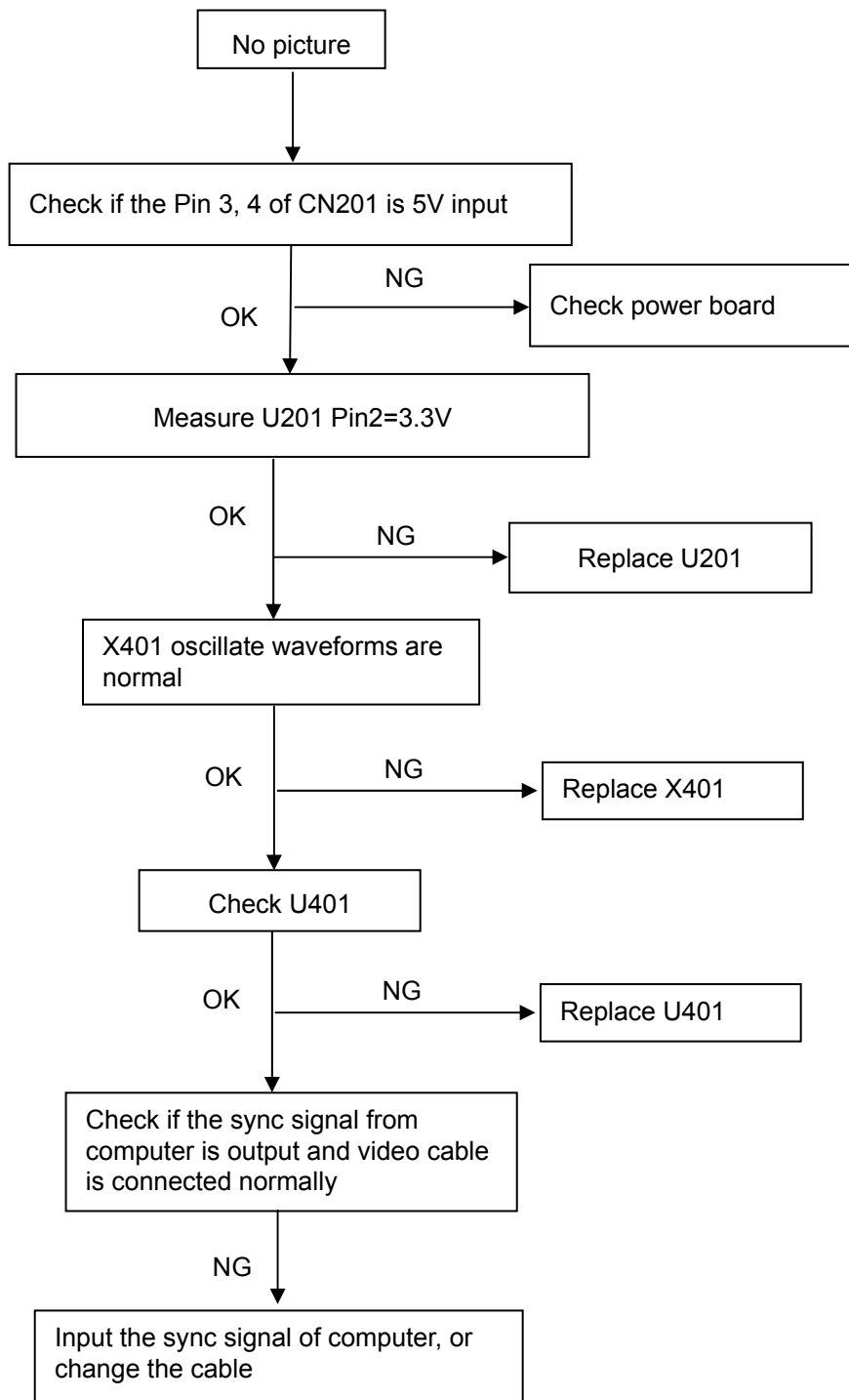

(3) White screen

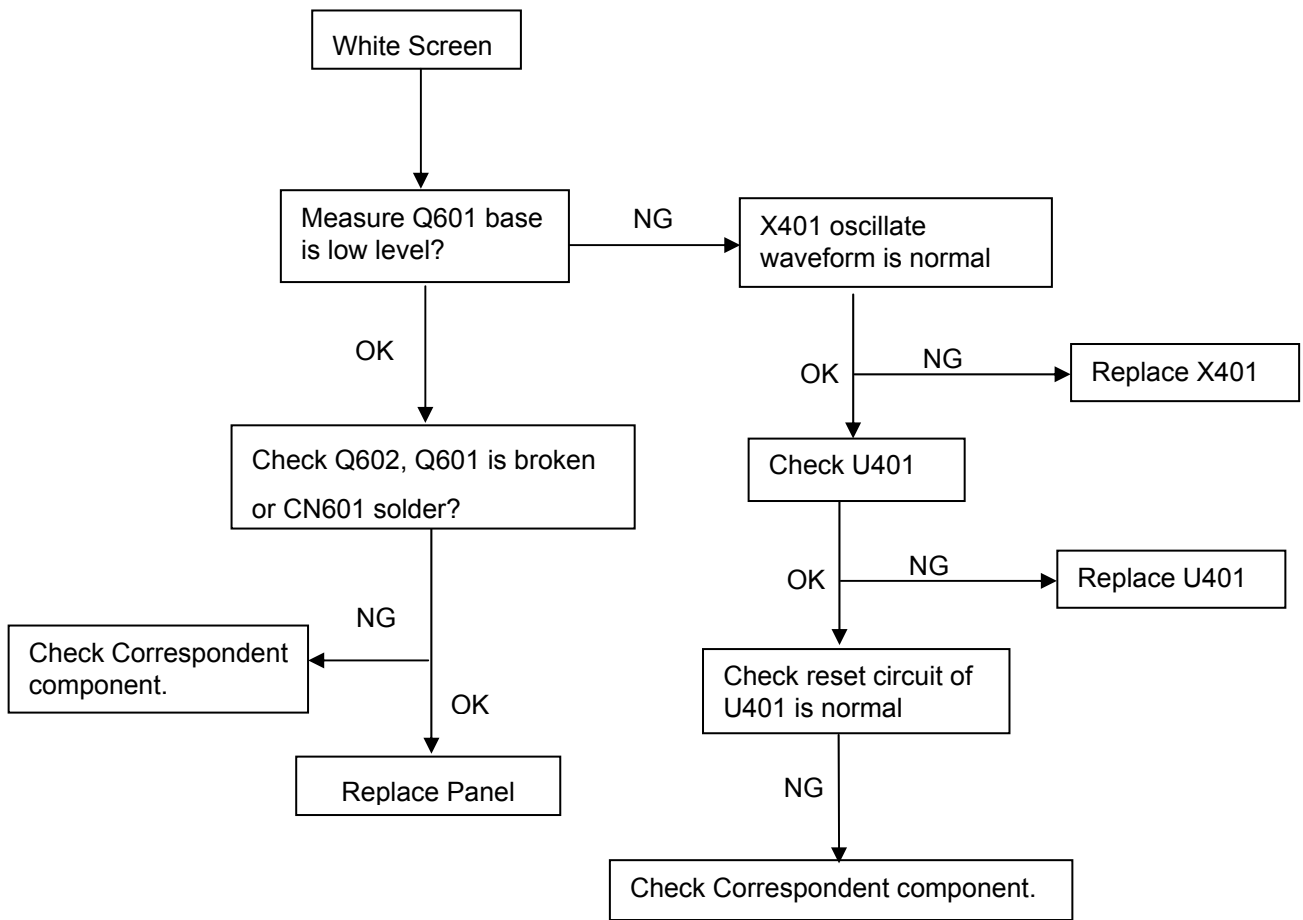

Power Board

No power

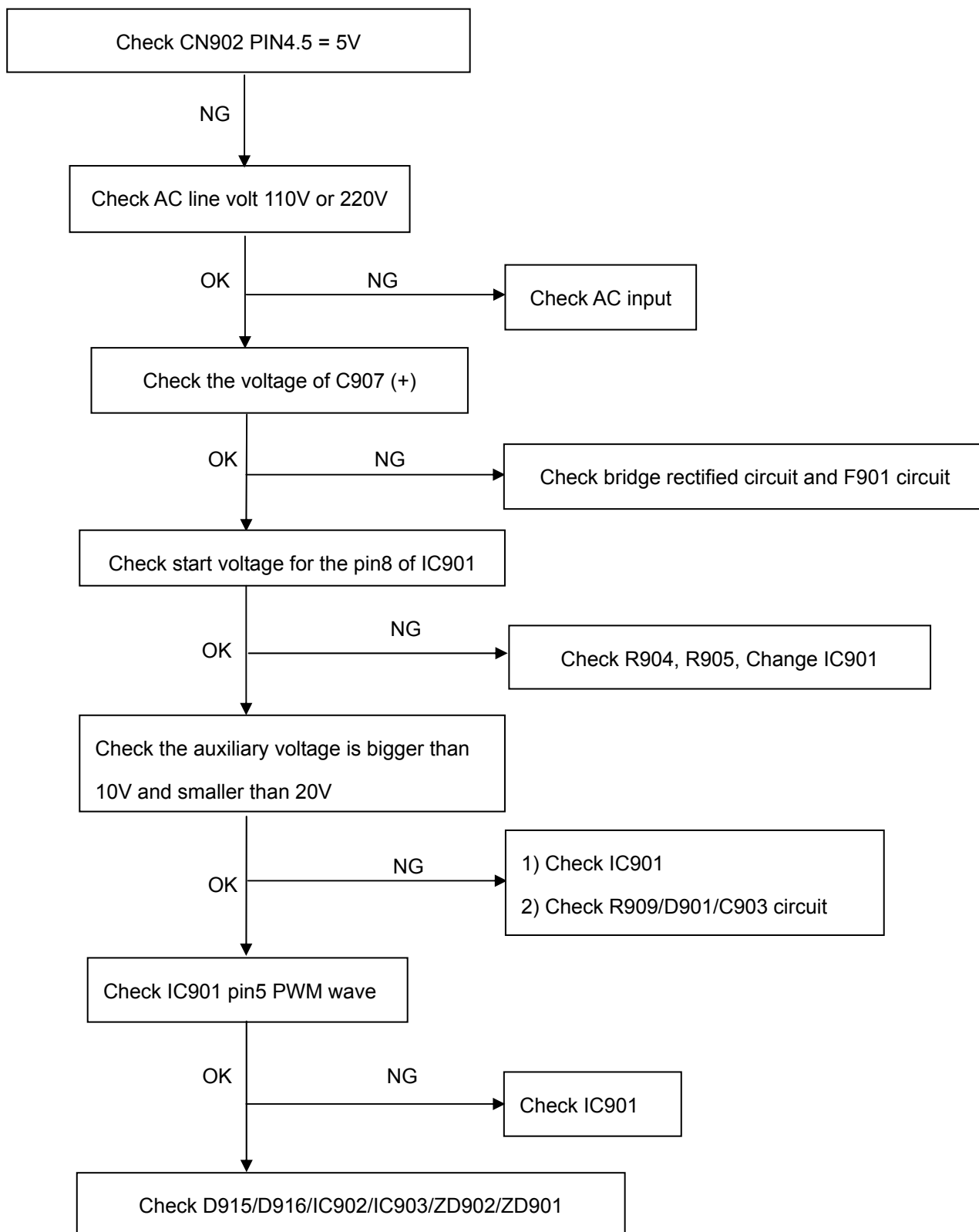

W / LED, No Backlight

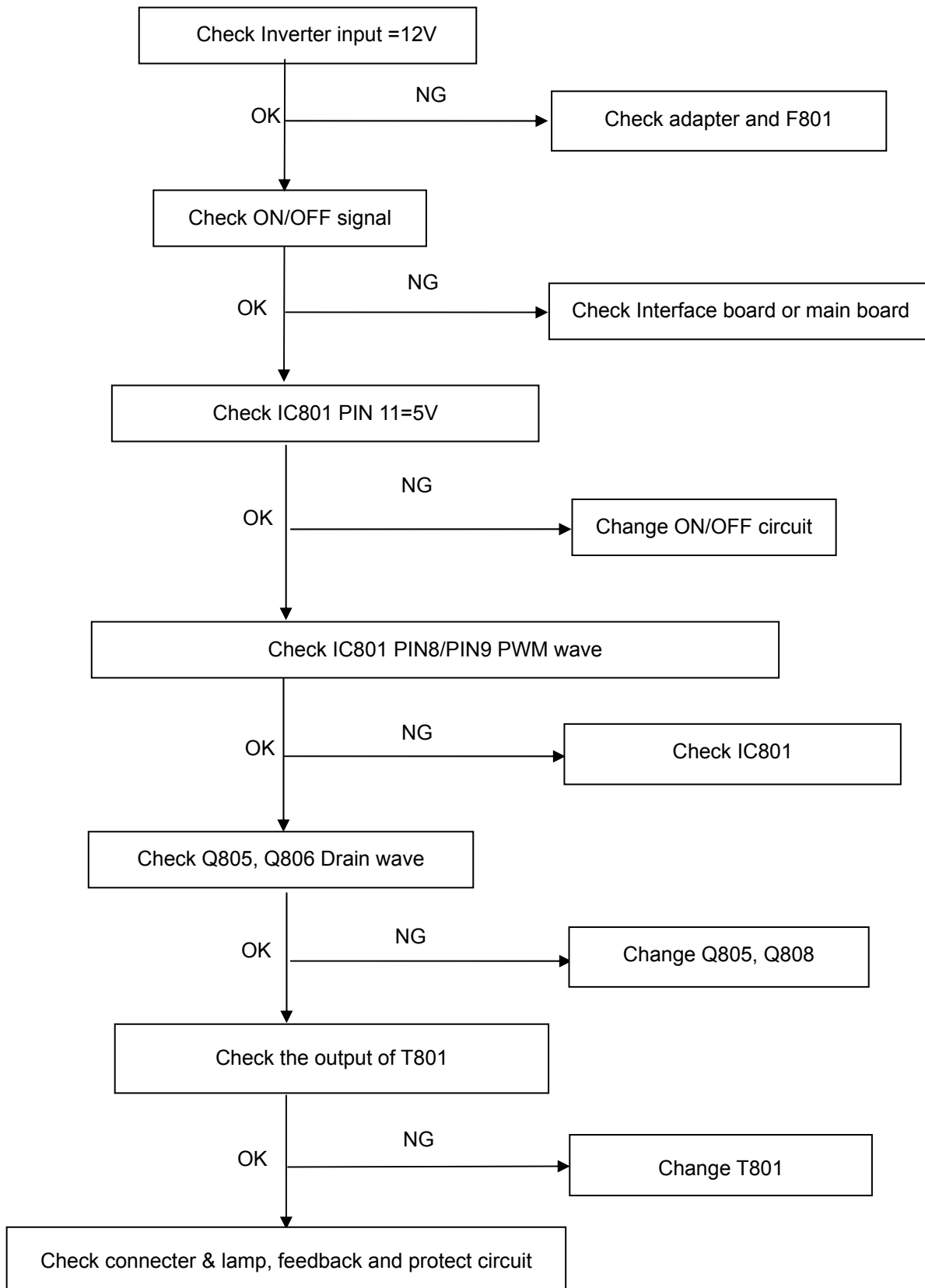

Key Board

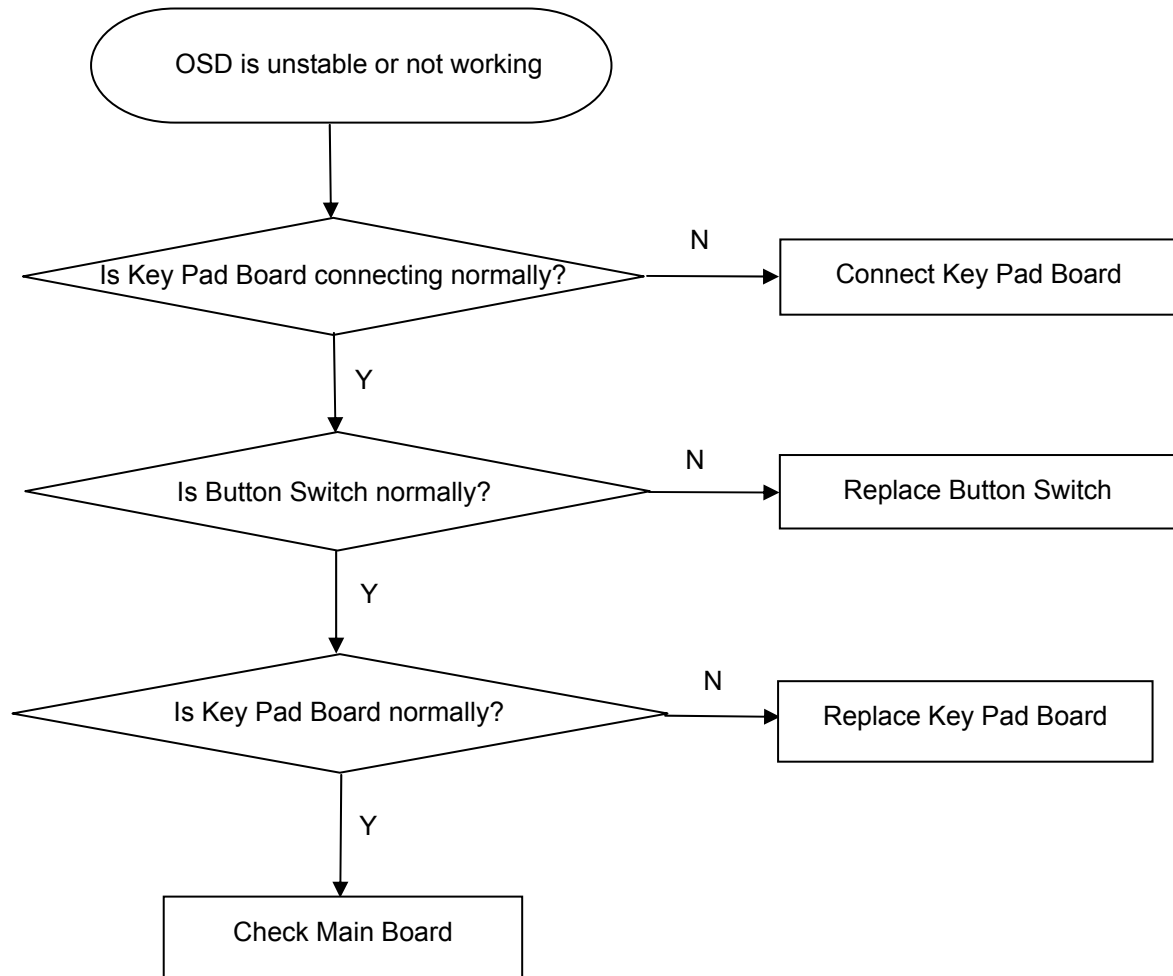

PCB LAYOUT

Main Board

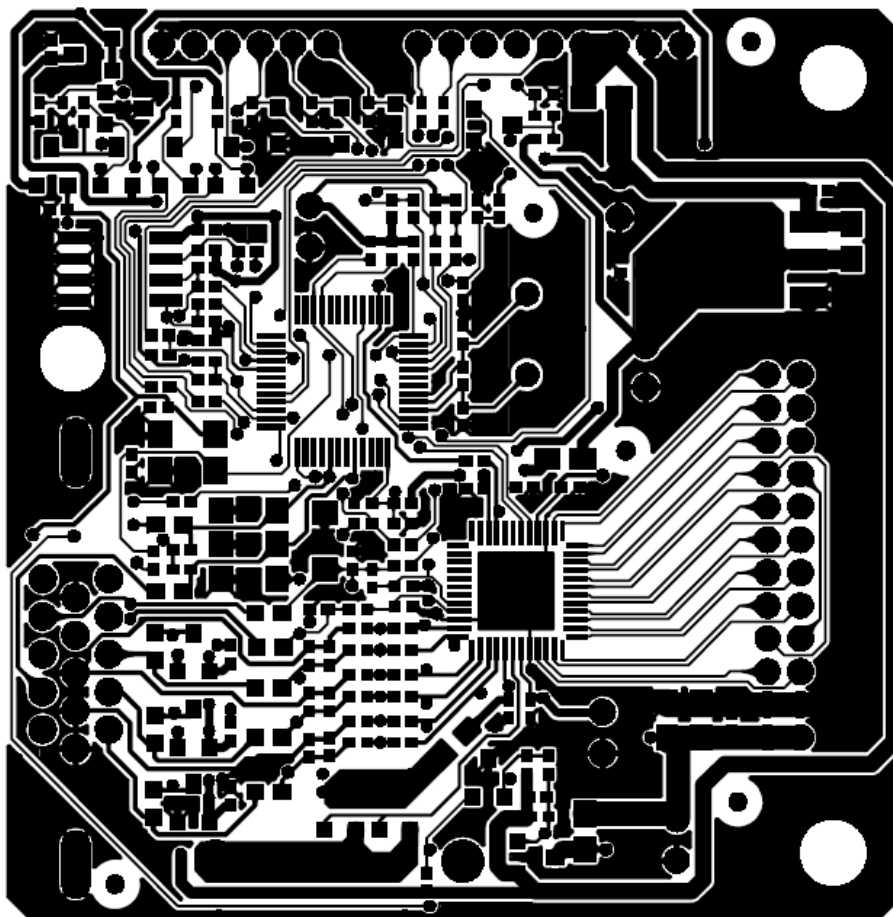
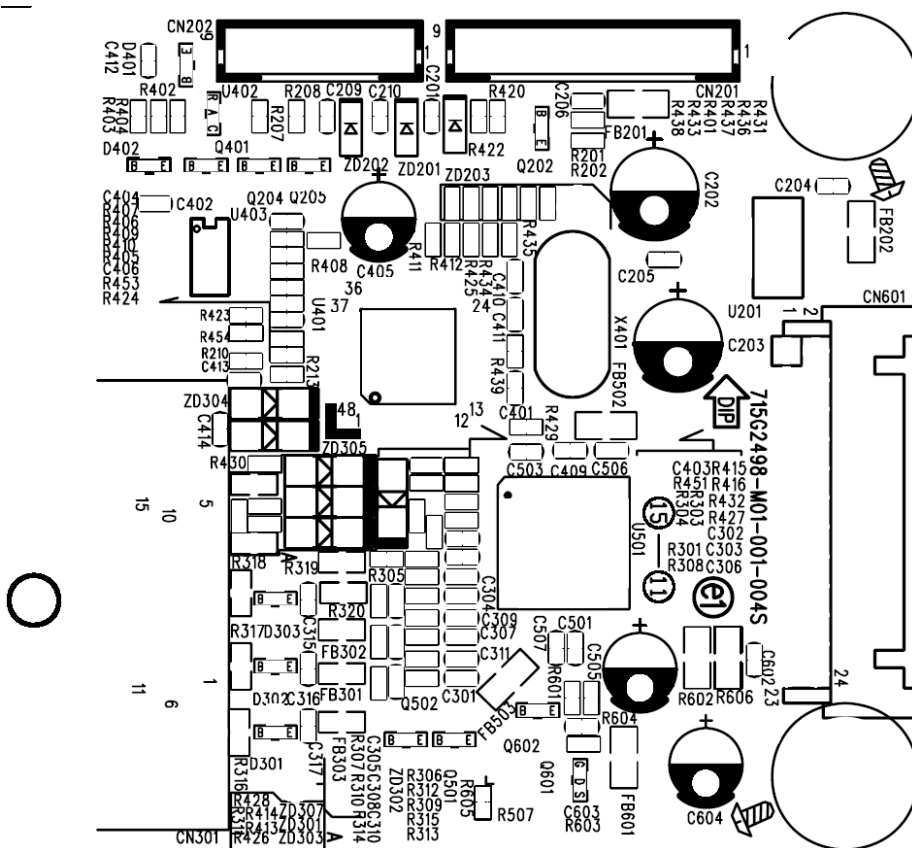

Appendix 1 – Screw List / Torque

(TA9SRKMBFWBQNN)

Part No.	Type	Description	Quantity	Torque
0M1G1030 6120	M3*6	FOR POWER BOARDS & MAIN FRAME	3	6±1KGF.CM
0M1G1030 6120	M3*6	FOR MAIN BOARDS & MAIN FRAME	2	6±1KGF.CM
0M1G1740 8 47 CR3	Q4*8	FOR HINGE & STAND	1	6±2KGF. CM
AQ1G1740 12120	M4*12	FOR HINGE & STAND	2	6±2KGF. CM
AM1G1740 12 47 CR3	M4*12	HINGE & REAR COVER	2	12±2KGF. CM
0M1G1730 8120	M3*8	FOR HEAT SINK	1	~
0M1G1730 8120	M3*8	FOR HEAT SINK	1	~