

Service
Service
Service

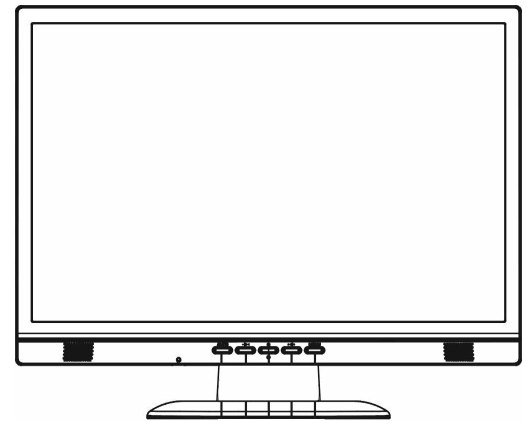

Service Manual

Horizontal Frequency
30 kHz-80 kHz

TABLE OF CONTENTS

Description	Page	Description	Page
Table Of Contents	1	6. Schematic	19
Revision List	2	6.1 Main Board	19
Important Safety Notice	3	6.2 Power Board	24
1. Monitor Specification	4	6.3 Key Board	26
2. LCD Monitor Description	5	6.4 Audio Board	27
3. Operation Instruction	6	7. PCB Layout	28
3.1 General Instructions	6	7.1 Main Board	28
3.2 Control Button	6	7.2 Power Board	31
3.3 Adjusting the Picture	8	7.3 Audio Board	33
4. Input/Output Specification	10	7.4 Keypad Board	33
4.1 Input Signal Connector	10	8. Maintainability	34
4.2 Factory Preset Display Modes	11	8.1. Equipments and Tools Requirement	34
4.3 Panel Specification	12	8.2. Trouble Shooting	35
5. Block Diagram	15	9. White-Balance, Luminance adjustment	41
5.1 Software Flow Chart	15	10. Monitor Exploded View	42
5.2 Electrical Block Diagram	17	11. BOM List	43

SAFETY NOTICE

ANY PERSON ATTEMPTING TO SERVICE THIS CHASSIS MUST FAMILIARIZE HIMSELF WITH THE CHASSIS AND BE AWARE OF THE NECESSARY SAFETY PRECAUTIONS TO BE USED WHEN SERVICING ELECTRONIC EQUIPMENT CONTAINING HIGH VOLTAGES.

CAUTION: USE A SEPARATE ISOLATION TRANSFORMER FOR THIS UNIT WHEN SERVICING

Important Safety Notice

Proper service and repair is important to the safe, reliable operation of all AOC Company Equipment. The service procedures recommended by AOC and described in this service manual are effective methods of performing service operations. Some of these service operations require the use of tools specially designed for the purpose. The special tools should be used when and as recommended.

It is important to note that this manual contains various CAUTIONS and NOTICES which should be carefully read in order to minimize the risk of personal injury to service personnel. The possibility exists that improper service methods may damage the equipment. It is also important to understand that these CAUTIONS and NOTICES ARE NOT EXHAUSTIVE. AOC could not possibly know, evaluate and advise the service trade of all conceivable ways in which service might be done or of the possible hazardous consequences of each way. Consequently, AOC has not undertaken any such broad evaluation. Accordingly, a servicer who uses a service procedure or tool which is not recommended by AOC must first satisfy himself thoroughly that neither his safety nor the safe operation of the equipment will be jeopardized by the service method selected.

Hereafter throughout this manual, AOC Company will be referred to as AOC.

WARNING

Use of substitute replacement parts, which do not have the same, specified safety characteristics may create shock, fire, or other hazards.

Under no circumstances should the original design be modified or altered without written permission from AOC. AOC assumes no liability, express or implied, arising out of any unauthorized modification of design.

Servicer assumes all liability.

FOR PRODUCTS CONTAINING LASER:

DANGER-Invisible laser radiation when open AVOID DIRECT EXPOSURE TO BEAM.

CAUTION-Use of controls or adjustments or performance of procedures other than those specified herein may result in hazardous radiation exposure.

CAUTION -The use of optical instruments with this product will increase eye hazard.

TO ENSURE THE CONTINUED RELIABILITY OF THIS PRODUCT, USE ONLY ORIGINAL MANUFACTURER'S REPLACEMENT PARTS, WHICH ARE LISTED WITH THEIR PART NUMBERS IN THE PARTS LIST SECTION OF THIS SERVICE MANUAL.

Take care during handling the LCD module with backlight unit

-Must mount the module using mounting holes arranged in four corners.

-Do not press on the panel, edge of the frame strongly or electric shock as this will result in damage to the screen.

-Do not scratch or press on the panel with any sharp objects, such as pencil or pen as this may result in damage to the panel.

-Protect the module from the ESD as it may damage the electronic circuit (C-MOS).

-Make certain that treatment person's body is grounded through wristband.

-Do not leave the module in high temperature and in areas of high humidity for a long time.

-Avoid contact with water as it may a short circuit within the module.

-If the surface of panel becomes dirty, please wipe it off with a soft material. (Cleaning with a dirty or rough cloth may damage the panel.)

1. Monitor Specifications

LCD Panel	Driving system	TFT Color LCD
	Size	48cm(19.0")
	Pixel pitch	0.2835mm(H) × 0.2835mm(V)
Input	Video	R,G,B Analog Interface
	Separate Sync.	H/V TTL
	H-Frequency	30kHz – 80kHz
	V-Frequency	55-75Hz
Display Colors		16.2M Colors
Dot Clock		135MHz
Max. Resolution		1440 × 900 @60Hz
Plug & Play		VESA DDC2B™
EPA ENERGY STAR®	ON Mode	≤36W
	OFF Mode	≤1W
Input Connector		15-pin D-Sub
Input Video Signal		Analog:0.7Vp-p(standard), 75 OHM, Positive
Maximum Screen Size		Horizontal : 408.24mm Vertical : 255.15mm
Power Source		100~240VAC,50~60Hz
Environmental Considerations		Operating Temp: 5° to 50°C Storage Temp.: -20° to 60°C Operating Humidity: 10% to 85%
Dimension		425 (W)×418 (H)×207 (D)mm
Weight (N. W.)		5.9kg Unit (net)
Power Consumption(Maximum)		36 Watts
Audio Output		Rated Power 1.5 W rms (Per channel)
Regulatory Compliance		FCC, UL, CUL, TUV-S

2. LCD Monitor Description

The LCD MONITOR will contain a main board, a power board, an audio board and a key board which house the flat panel control logic, brightness control logic and DDC.

The power board will provide AC to DC Inverter voltage to drive the backlight of panel and the main board chips each voltage.

Monitor Block Diagram

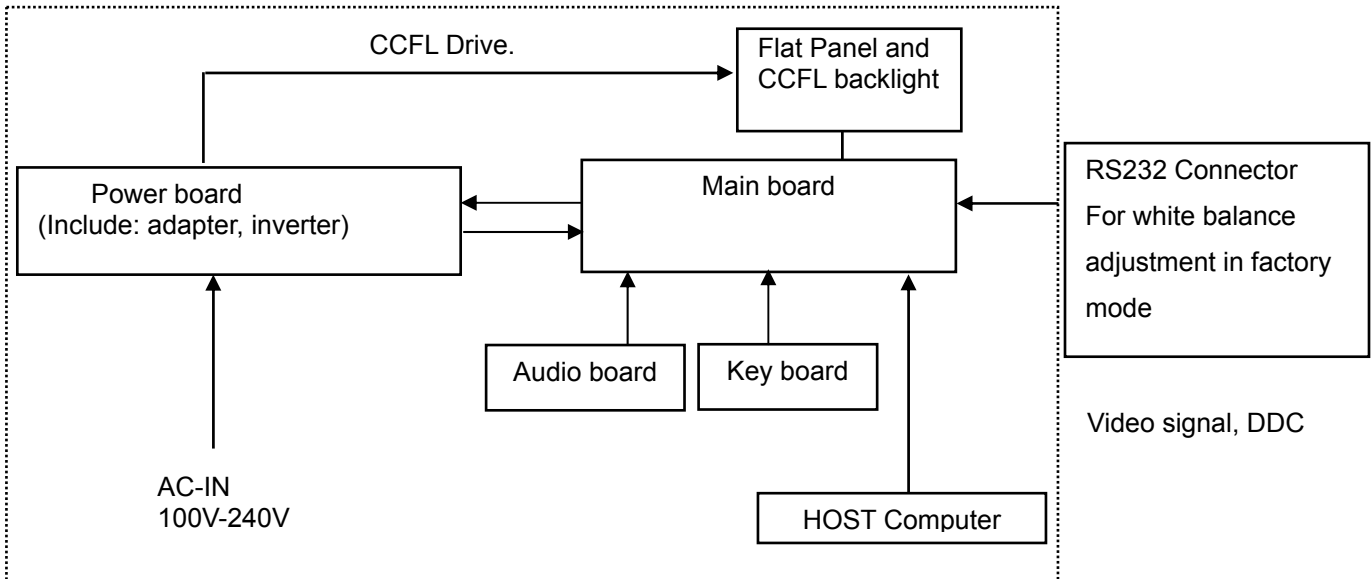

3. Operating Instructions

3.1 General Instructions

Press the power button to turn the monitor on or off. The control buttons are located in the front of the monitor.

By changing these settings, the picture can be adjusted to your personal preferences.

- The power cord should be connected.
- Connect the video cable from the monitor to the video card.
- Press the power button to turn on the monitor, the power indicator will light up.

3.2 Control Buttons

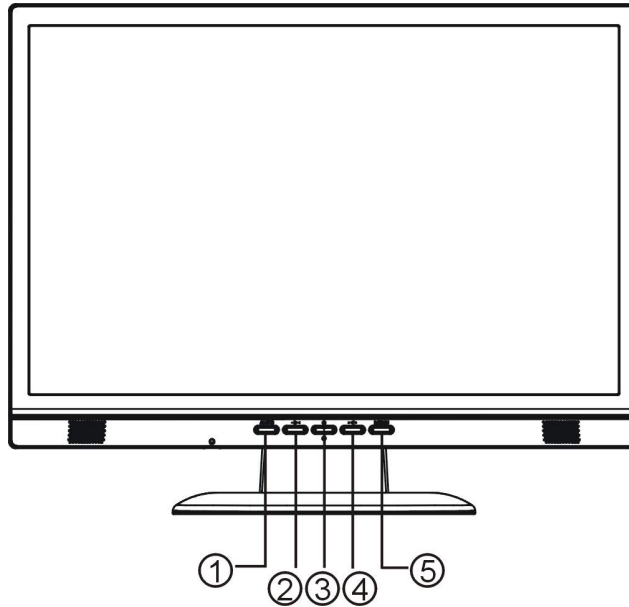

EXTERNAL CONTROLS

1.	Auto Adjust Key/Exit	4.	> / Volume
2.	< / Volume	5.	MENU/ENTER
3.	Power Key/ LED		

FRONT PANEL CONTROL**• Power Button / Power Indicator:**

Press this button to turn the monitor ON or OFF.

Green — Power On mode.

Orange — Off mode.

• MENU / ENTER:

Activate OSD menu when OSD is OFF or activate/de-activate adjustment function when OSD is ON or Exit OSD menu when in Volume Adjust OSD status.

• > /Volume:

Activates the volume control when the OSD is OFF or navigate through adjustment icons when OSD is ON or adjust a function when function is activated.

• < /Volume:

Activates the volume control when the OSD is OFF or navigate through adjustment icons when OSD is ON or adjust a function when function is activated.

• Auto Adjust button / Exit:

1. When OSD menu is in active status, this button will act as EXIT-KEY (EXIT OSD menu).
2. When OSD menu is in off status, press this button for 2 seconds to activate the Auto Adjustment function.

The Auto Adjustment function is used to set the HPos, VPos, Clock and Focus.

OSD Lock Function: To lock the OSD, press and hold the MENU button while the monitor is off and then press power button to turn the monitor on. To un-lock the OSD - press and hold the MENU button while the monitor is off and then press power button to turn the monitor on.

NOTES

- Do not install the monitor in a location near heat sources such as radiators or air ducts, or in a place subject to direct sunlight, or excessive dust or mechanical vibration or shock.
- Save the original shipping carton and packing materials, as they will come in handy if you ever have to ship your monitor.
- For maximum protection, repackage your monitor as it was originally packed at the factory.
- To maintain the cleanness of your LCD display, wipe it periodically with clean and soft cloth. The screen may be damaged by any liquid splash.
- To keep the monitor looking new, periodically clean it with a soft cloth. Stubborn stains may be removed with a cloth lightly dampened with a mild detergent solution. Never use strong solvents such as thinner, benzene, or abrasive cleaners, since these will damage the cabinet. As a safety precaution, always unplug the monitor before cleaning it.

3.3 Adjusting the Picture





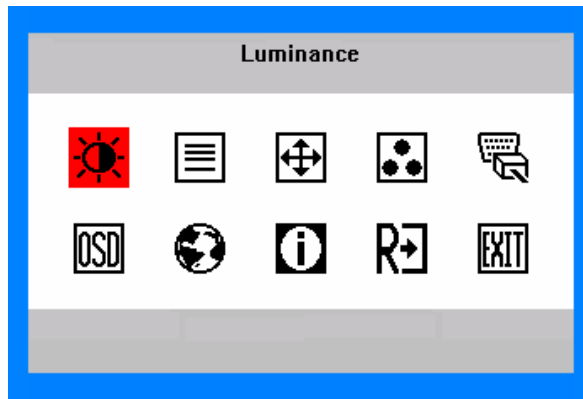



Adjustment steps:

1. Press the MENU-button to activate the OSD window.
2. Press < or > to navigate through the functions. Once the desired function is highlighted, press the MENU-button to activate it. If the function selected has a sub-menu, press < or > again to navigate through the sub-menu functions. Once the desired function is highlighted, press MENU-button to activate it.
3. Press < or > to change the settings of the selected function.
4. To exit and save, select the exit function. If you want to adjust any other function, repeat steps 2-3.



The OSD Message

Main Menu Item	Main Menu Icon	Sub Menu Item	Sub Menu Icon	Description
Luminance		Contrast		Contrast from Digital-register.
		Brightness		Backlight Adjustment
Image Setup		Focus		Adjust Picture Phase to reduce Horizontal-Line noise
		Clock		Adjust picture Clock to reduce Vertical-Line noise.
Image Position		H. Position		Adjust the horizontal position of the picture.
		V. Position		Adjust the vertical position of the picture.
Color Temp.		Warm	N/A	Recall Warm Color Temperature from EEPROM.
		Cool	N/A	Recall Cool Color Temperature from EEPROM.
		sRGB	N/A	Recall sRGB Temperature from EEPROM.
		User / Red	R	Red Gain from Digital-register.
		User / Green	G	Green Gain Digital-register.
		User / Blue	B	Blue Gain from Digital-register.

Main Menu Item	Main Menu Icon	Sub Menu Item	Sub Menu Icon	Description
Input Select		Analog	N/A	Select input signal from analog source (D-Sub).
		Digital	N/A	Select input signal from digital source (DVI).
OSD Setup		H. Position		Adjust the horizontal position of the OSD.
		V. Position		Adjust the vertical position of the OSD.
		OSD Timeout		Adjust the OSD timeout.
Language		Language	N/A	Set OSD language
Information		Information	N/A	Show the resolution, H/V frequency and input port of current input timing.
Reset		Yes	N/A	Clear each old status of Auto-configuration.
		No	N/A	Do not execute reset, return to main menu.
Exit		N/A	N/A	Exit OSD

4. Input/Output Specification

4.1 Input Signal Connector

Pin No.	Description	Pin No.	Description
1.	Red	9.	+5V
2.	Green	10.	Detect Cable
3.	Blue	11.	Ground
4.	Ground	12.	DDC-Serial Data
5.	Ground	13.	H-Sync
6.	R-Ground	14.	V-Sync
7.	G-Ground	15.	DDC-Serial Clock
8.	B-Ground		

15 - Pin Color Display Signal Cable

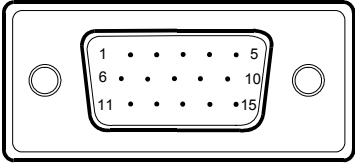

Pin No.	Description	Pin No.	Description
1.	TMDS Data 2-	13.	TMDS Data 3+
2.	TMDS Data 2+	14.	+5V Power
3.	TMDS Data 2/4 Shield	15.	Ground(for+5V)
4.	TMDS Data 4-	16.	Hot Plug Detect
5.	TMDS Data 4+	17.	TMDS Data 0-
6.	DDC Clock	18.	TMDS Data 0+
7.	DDC Data	19.	TMDS Data 0/5 Shield
8.	N.C.	20.	TMDS Data 5-
9.	TMDS Data 1-	21.	TMDS Data 5+
10.	TMDS Data 1+	22.	TMDS Clock Shield
11.	TMDS Data 1/3 Shield	23.	TMDS Clock +
12.	TMDS Data 3-	24.	TMDS Clock -

24 - Pin Color Display Signal Cable

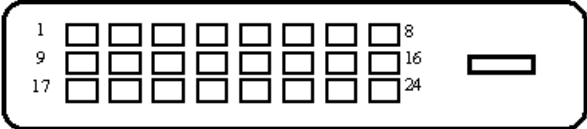

4.2 Factory Preset Display Modes

Standard	Resolution	Horizontal Frequency	Vertical Frequency
Dos-mode	720 x 400	31.47kHz	70.0Hz
VGA	640 × 480	31.47kHz	60.0Hz
	640 × 480	37.50kHz	75.0Hz
SVGA	800 × 600	37.879kHz	60.0Hz
	800 × 600	46.875kHz	75.0Hz
XGA	1024 × 768	48.363kHz	60.0Hz
	1024 × 768	56.476kHz	70.0Hz
	1024 × 768	60.021kHz	75.0Hz
SXGA	1280 × 1024	64.000kHz	60.0Hz
	1280 × 1024	80.000kHz	75.0Hz
WXGA+	1440×900	55.935 kHz	60.0 Hz

4.3 Panel Specification

HannStar Display model HSD190MGW1-A00 is a color active matrix thin film transistor (TFT) liquid crystal display (LCD) that uses amorphous silicon TFT as a switching device. This model is composed of a TFT LCD panel, the voltage reference, common voltage, DC-DC converter, column, and row driver circuit. This TFT LCD has a 19-inch diagonally measured active display area with WXGA+ resolution (900 vertical by 1440 horizontal pixel array).

4.3.1 Display Characteristics

Item	Specification		Unit
Outline dimension	428x278x18.5 (typ.)		mm
Display area	408.24 (H) x255.15 (V)		mm
Number of Pixel	1440(H) x 900(V)		Pixels
Pixel pitch	0.2835(H) x 0.2835(V)		mm
Pixel arrangement	RGB Vertical stripe		
Display color	16.2M (6-bit+FRC)		
Display mode	Normally white		
Surface treatment	Antiglare, Hard-Coating (3H)		
Weight	2200		G
Back-light	4-CCFLs, Top & bottom edge side		
Input signal	2-ch LVDS		
Power consumption	Logic system	2.7	W
	B/L system	22	W
Optimum viewing direction	6 o'clock		

4.3.2 Optical Characteristics

Item		Symbol	Condition	Min.	Typ.	Max.	Unit	
Contrast		CR	$\theta = 0^\circ$ $\phi = 0^\circ$ Normal viewing angle	450	700	--		
Response time	Rising	TR		--	1.5	3	msec	
	Falling	TF		--	3.5	7		
White luminance (center of screen)		Y_L			240	300	--	cd/m ²
White luminance (center of screen)		Y_L			280	350	--	cd/m ²
Color chromaticity (CIE1931)	Red	R_x			0.640	0.643	0.646	
		R_y			0.322	0.325	0.328	
	Green	G_x			0.292	0.295	0.298	
		G_y			0.613	0.616	0.619	
	Blue	B_x			0.140	0.143	0.146	
		B_y		0.078	0.081	0.084		
	White	W_x		0.280	0.310	0.340		
		W_y		0.300	0.330	0.360		
Viewing angle	Hor.	θ_L	CR>10	65	75	--		
		θ_R		65	75	--		
	Ver.	θ_H		65	75	--		
		θ_L		55	65	--		
Viewing angle	Hor.	θ_L	CR>5	75	85	--		
		θ_R		75	85	--		
	Ver.	θ_H		75	85	--		
		θ_L		65	75	--		
Brightness uniformity		B_{UNI}	$\theta = 0^\circ$ $\phi = 0^\circ$	--	75	--	%	

4.3.3 Parameter guide line for CCFL Inverter

TFT LCD Module:

Item	Symbol	Min.	Max.	Unit.
Power supply Voltage	VDD	-0.3	6.0	V(DC)

Back Light Unit:

Item	Symbol	Min.	Max.	Unit
Lamp current	I_L	3.0	9.0	MA
Lamp frequency	f_L	45	80	KHz

5. Block Diagram

5.1 Software Flow Chat

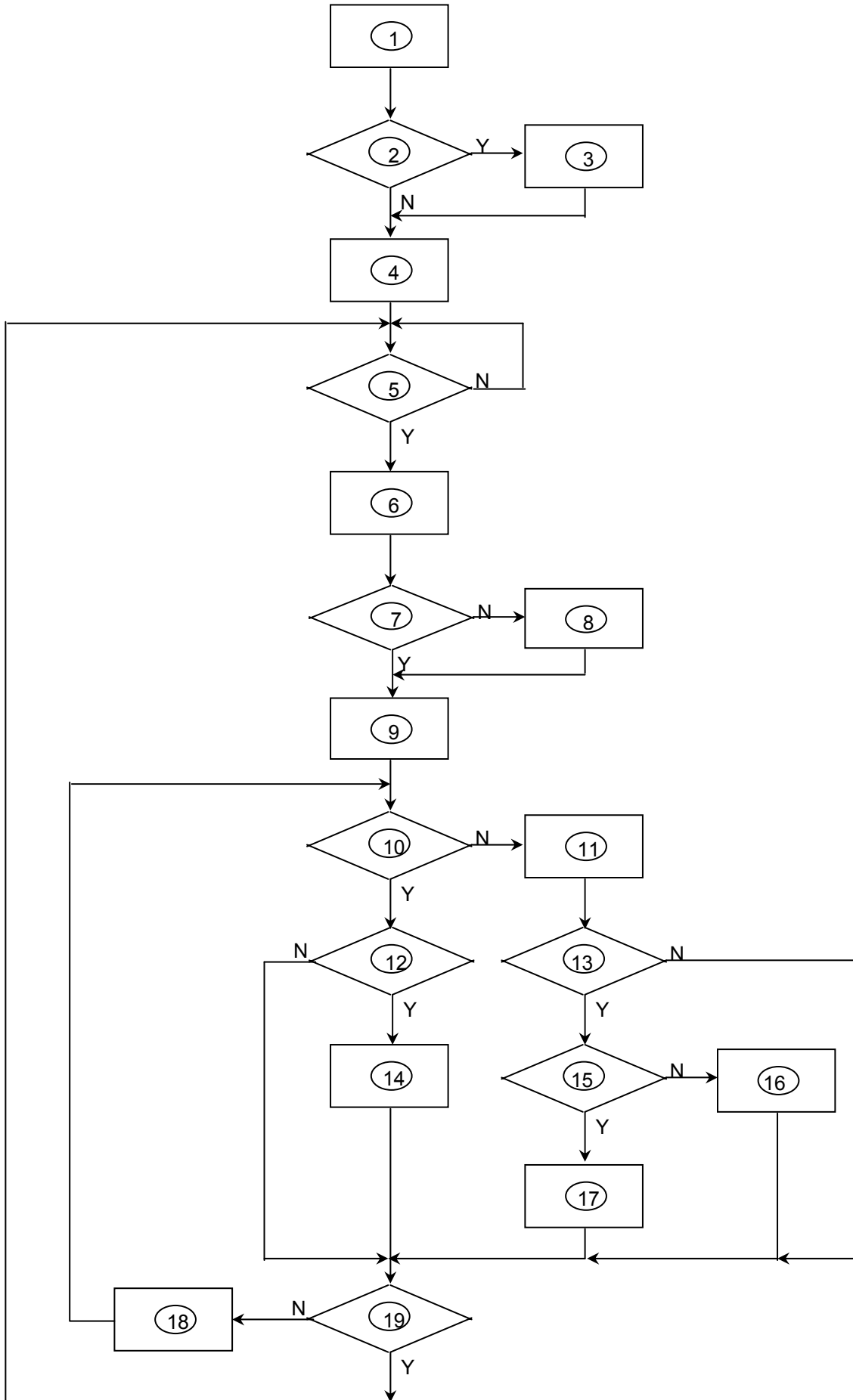

- 1) MCU initialize.
- 2) Is the EPROM blank?
- 3) Program the EPROM by default values.
- 4) Get the PWM value of brightness from EPROM.
- 5) Is the power key pressed?
- 6) Clear all global flags.
- 7) Are the AUTO and SELECT keys pressed?
- 8) Enter factory mode.
- 9) Save the power key status into EPROM.
Turn on the LED and set it to green color.
Scalar initializes.
- 10) In standby mode?
- 11) Update the lifetime of back light.
- 12) Check the analog port, are there any signals coming?
- 13) Does the scalar send out an interrupt request?
- 14) Wake up the scalar.
- 15) Are there any signals coming from analog port?
- 16) Display "No connection Check Signal Cable" message. And go into standby mode after the message disappear.
- 17) Program the scalar to be able to show the coming mode.
- 18) Process the OSD display.
- 19) Read the keyboard. Is the power key pressed?

5.2 Electric Block Diagram

5.2.1 Main Board

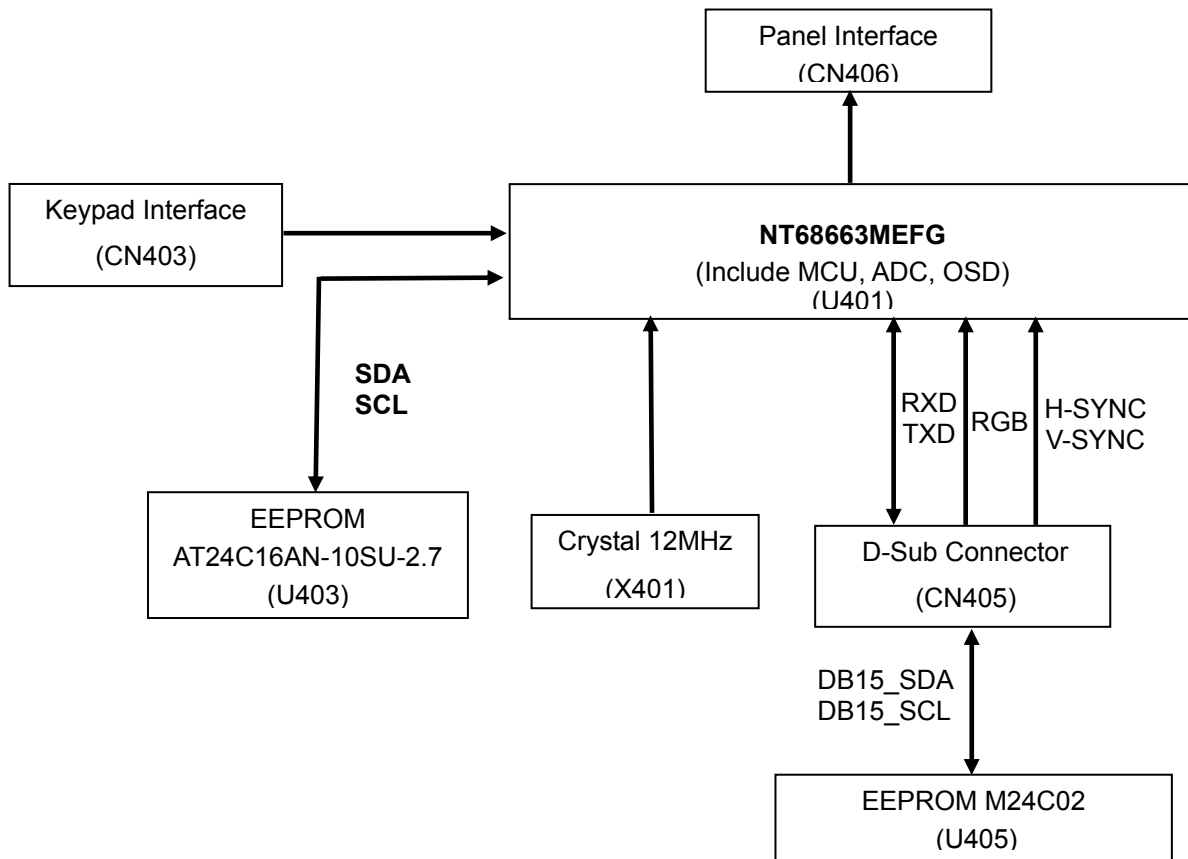

5.2.2 Inverter / Power Board

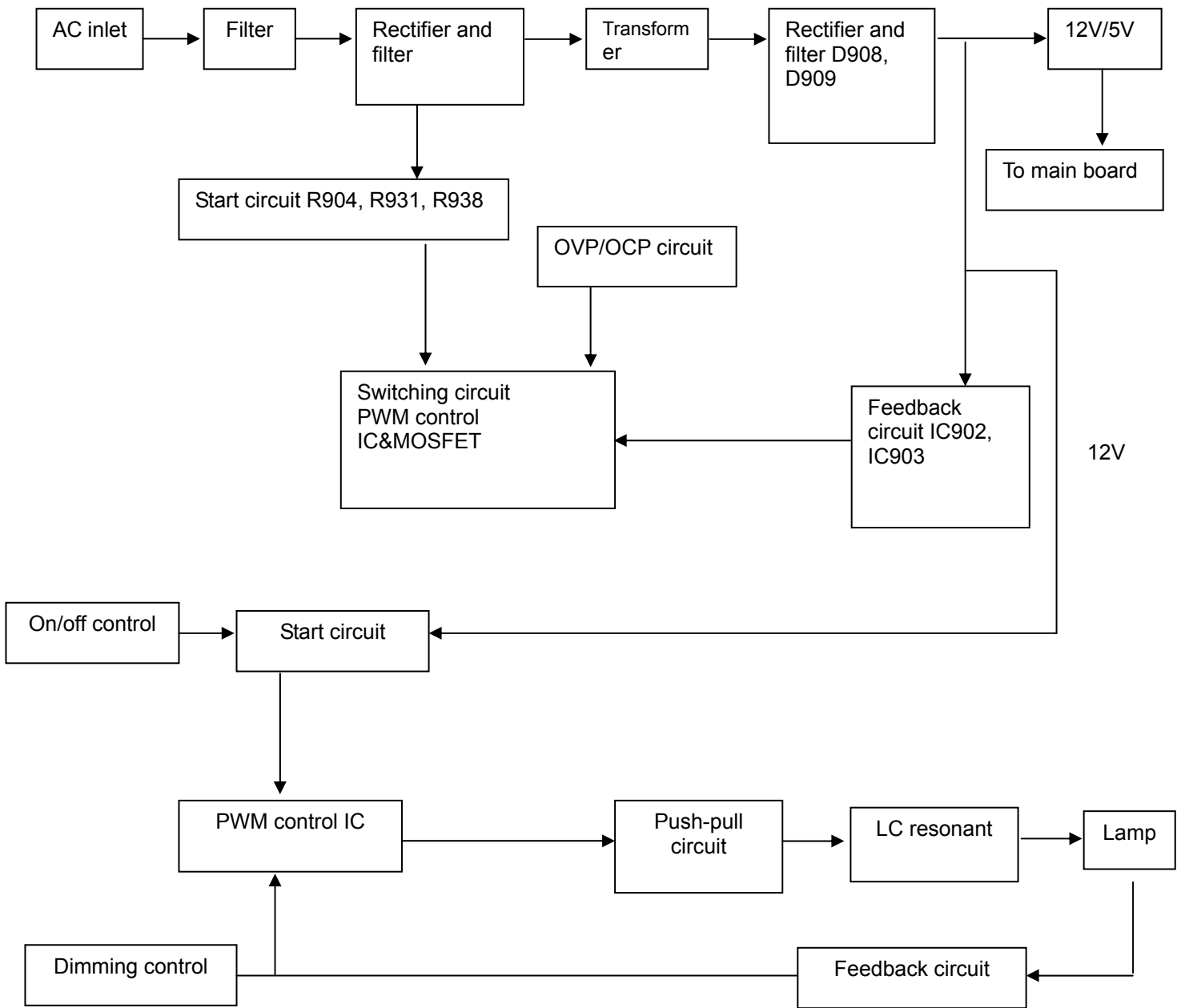

6. Schematic

6.1 Main Board

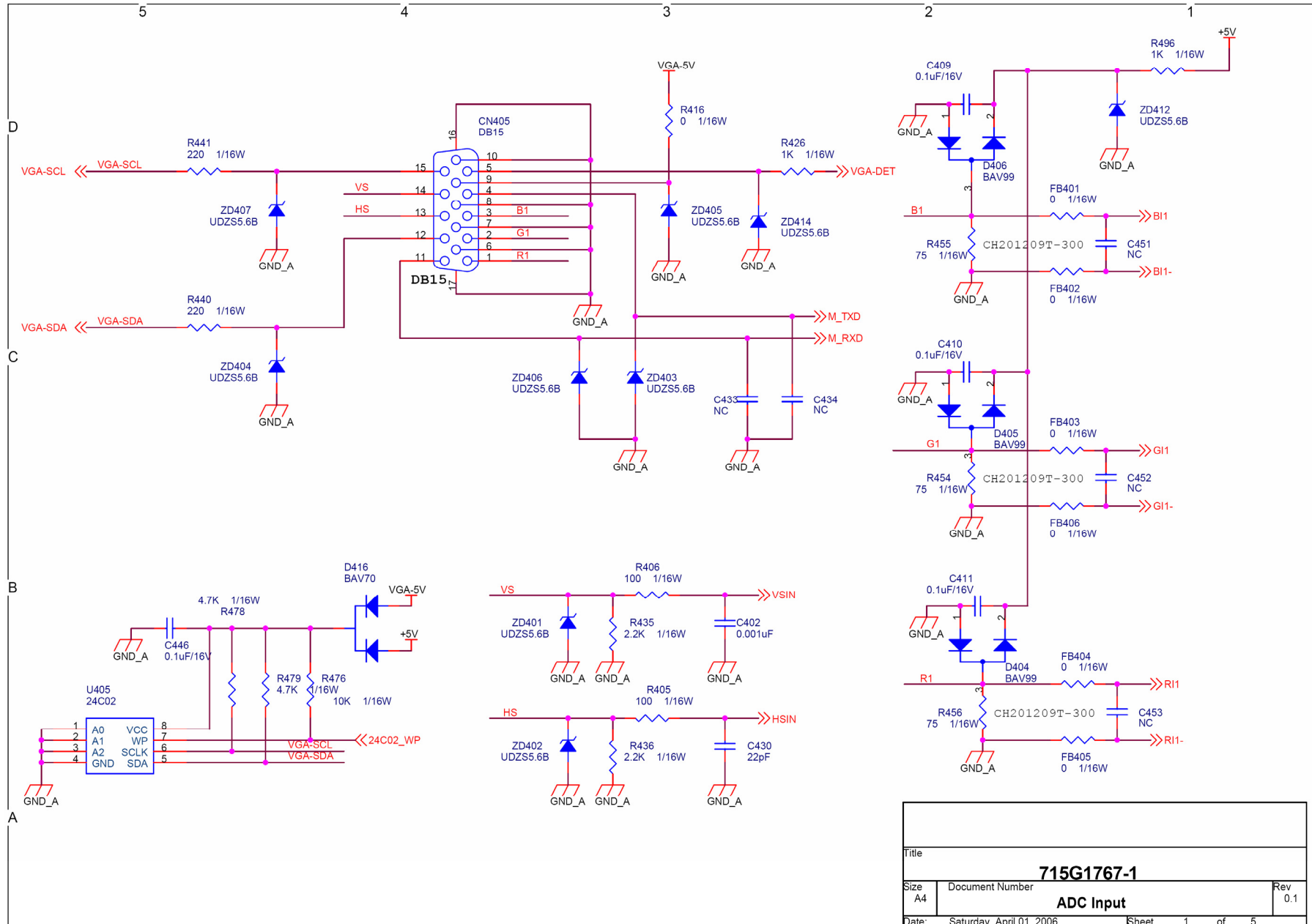

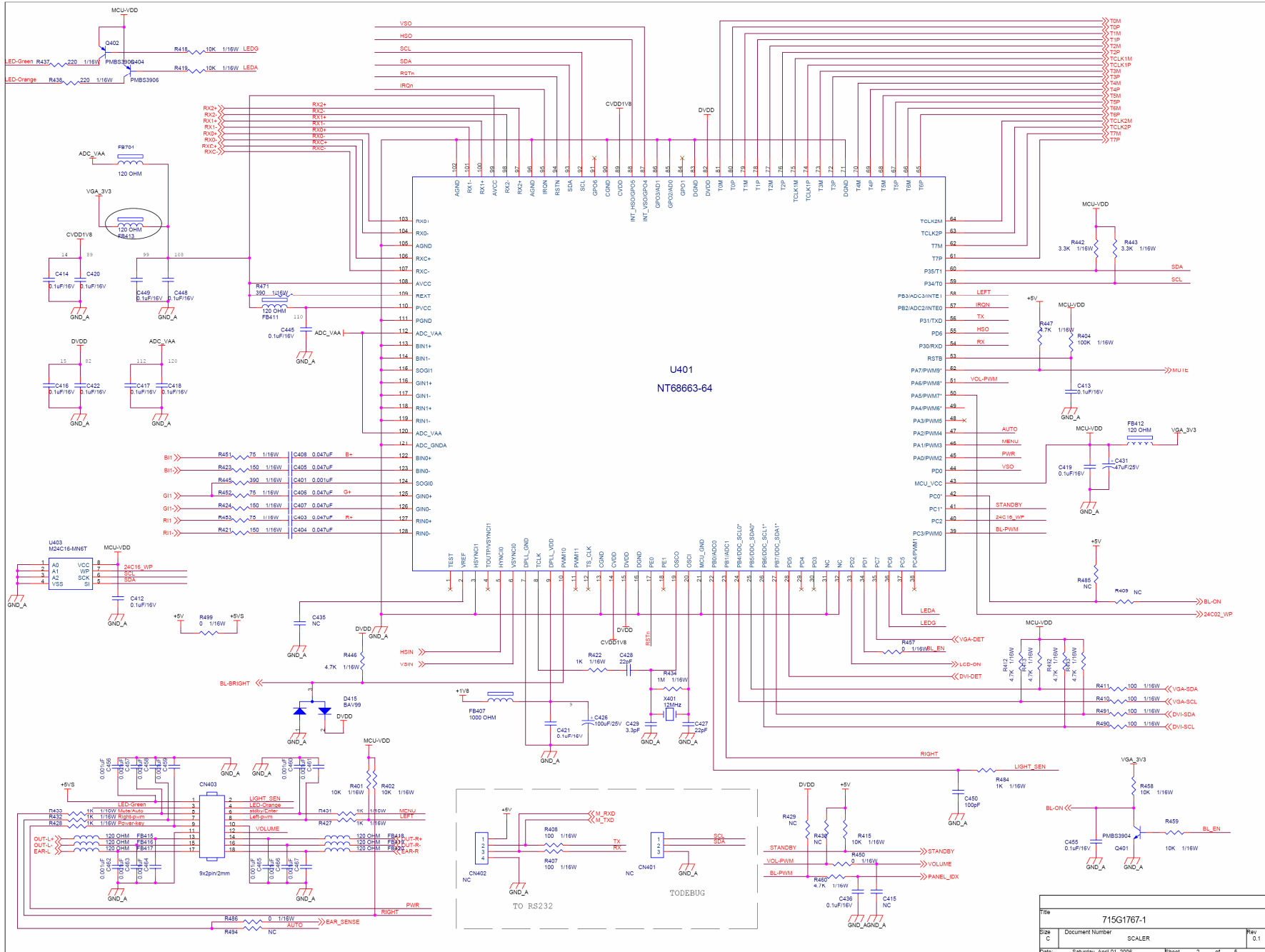

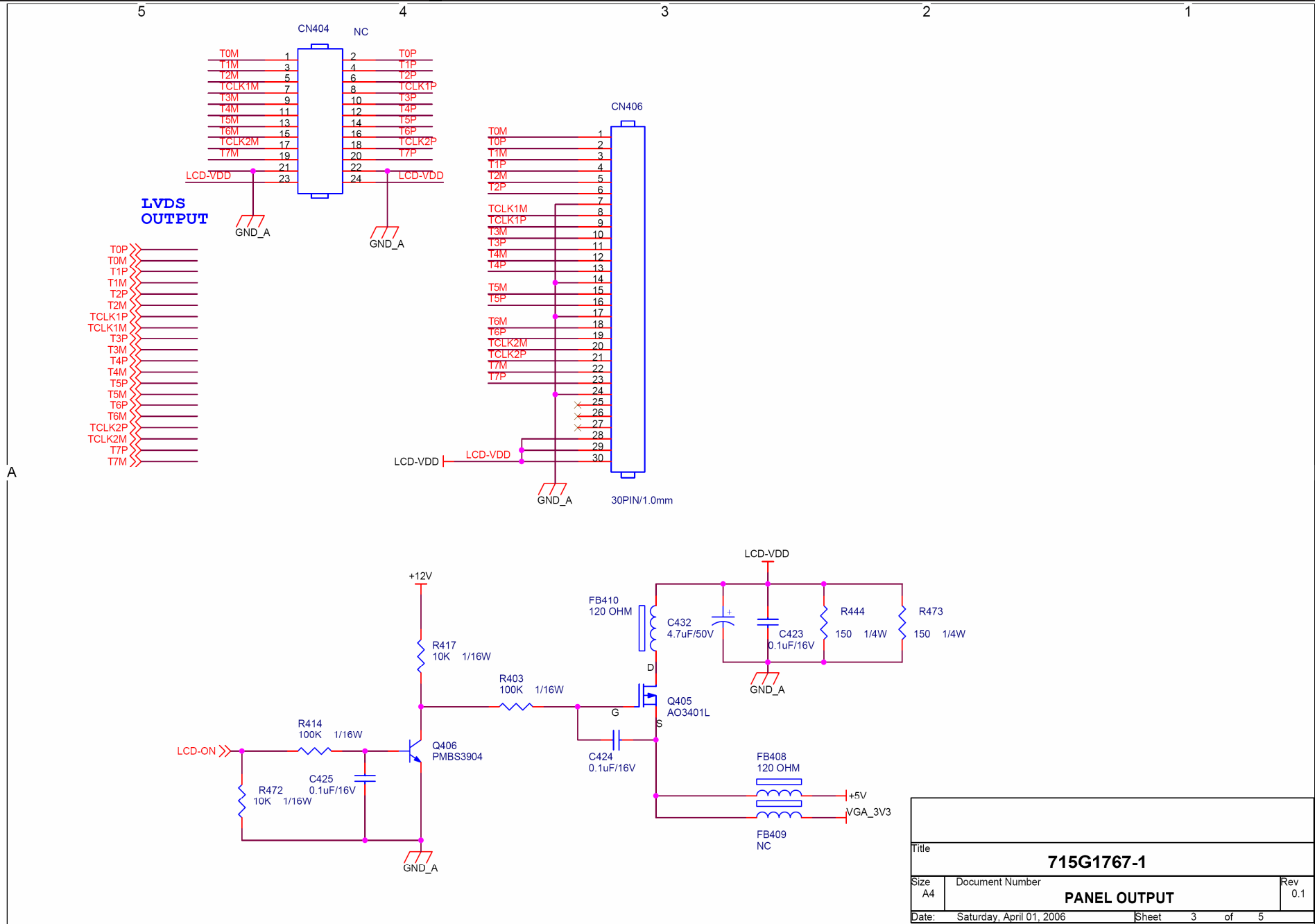

Title		
715G1767-1		
Size	Document Number	Rev
A4	PANEL OUTPUT	0.1
Date:	Saturday, April 01, 2006	Sheet 3 of 5

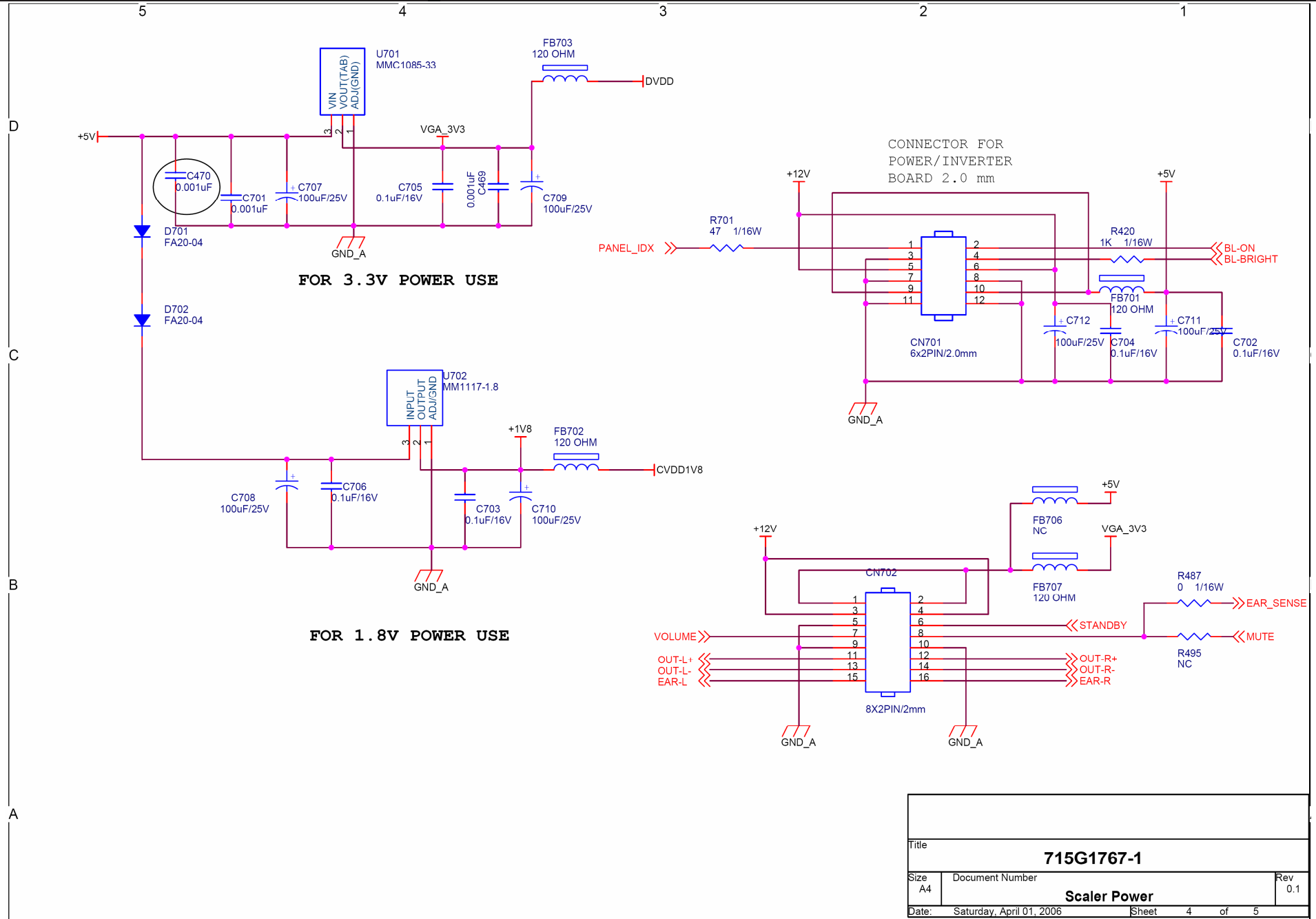

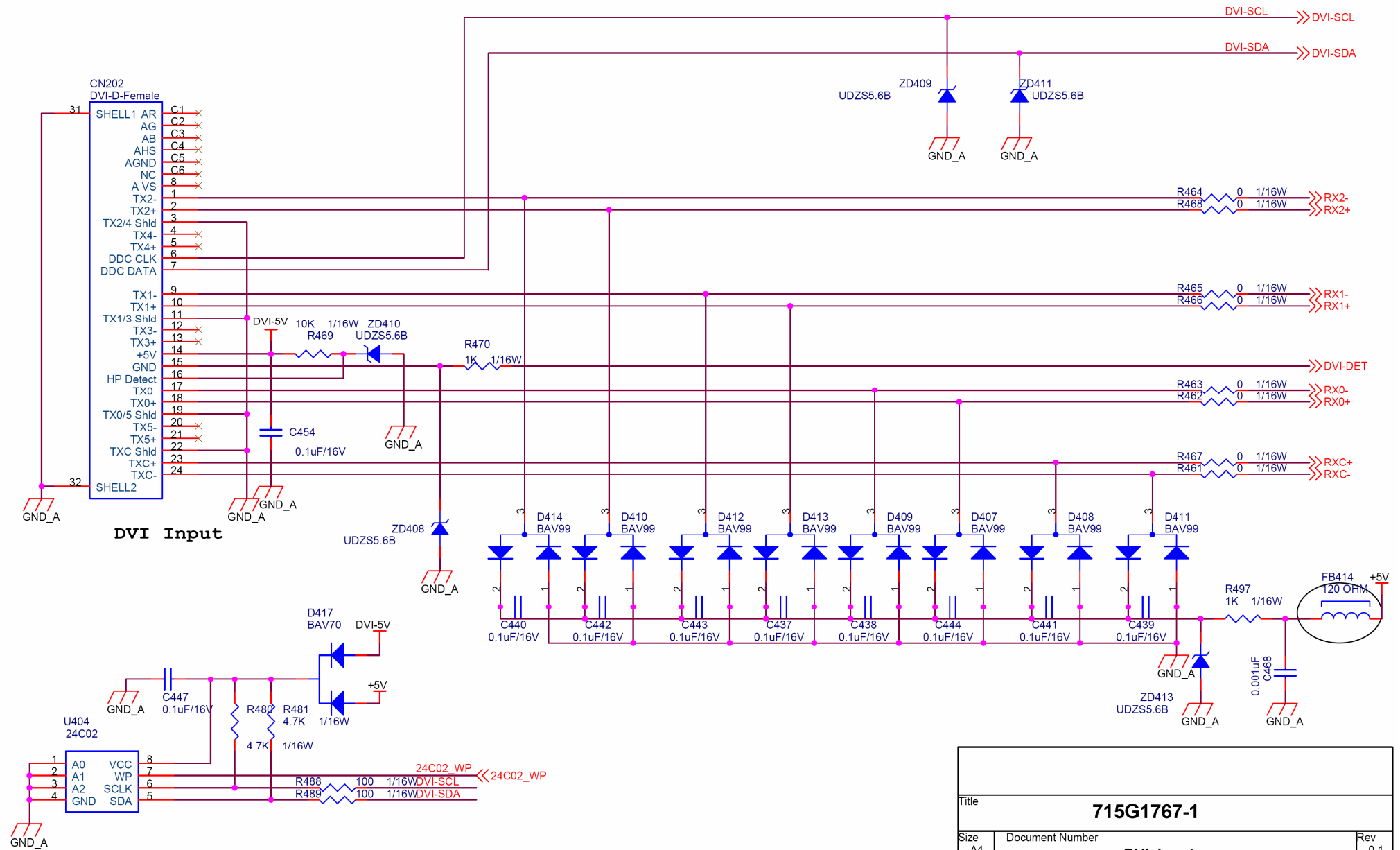

Title		
715G1767-1		
Size	Document Number	Rev
A4	DVI Input	0.1
Date:	Saturday, April 01, 2006	Sheet 5 of 5

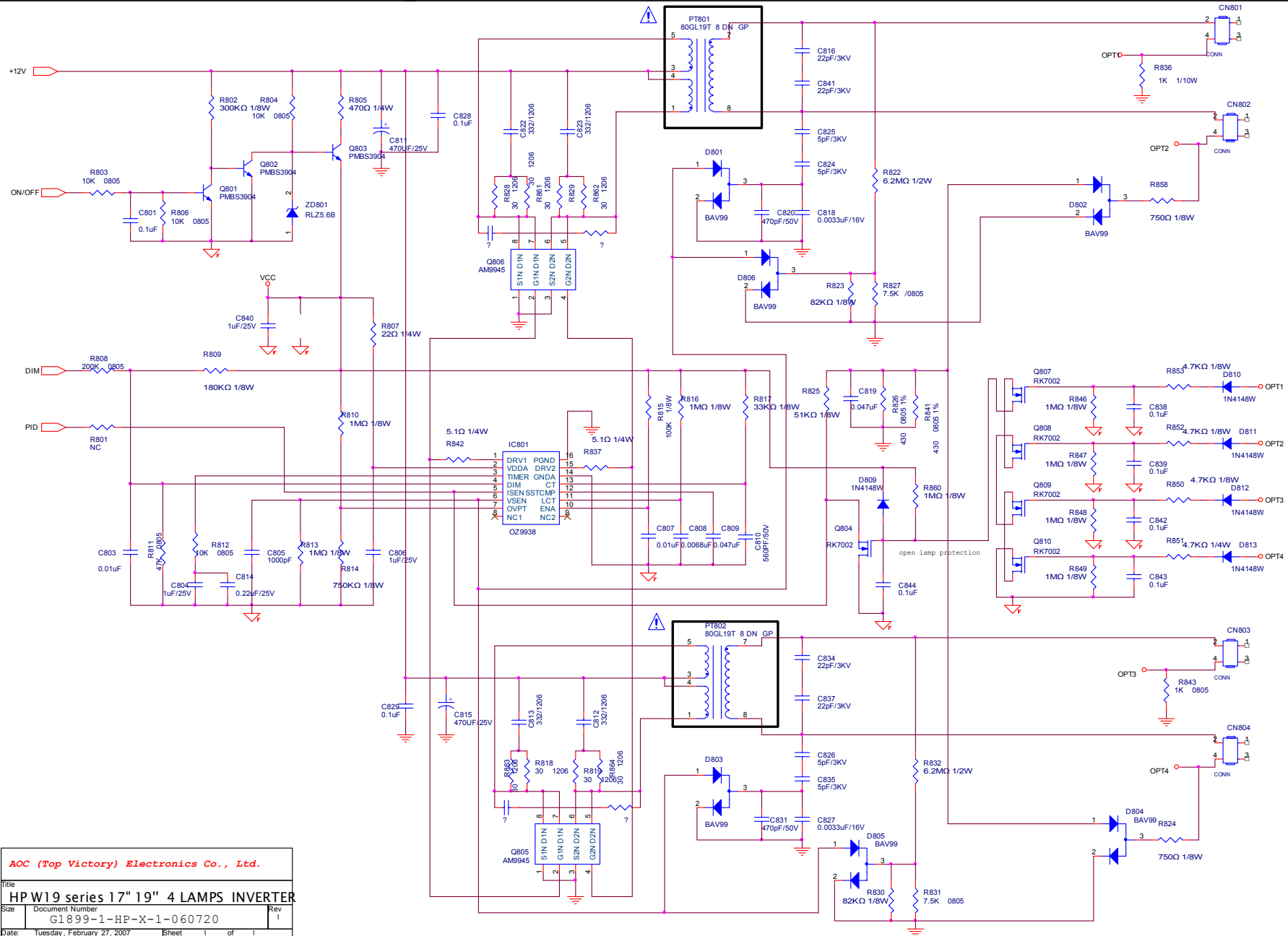

AOC (Top Victory) Electronics Co., Ltd.		
Title HP W19 series 17" 19" 4 LAMPS INVERTER		
Size	Document Number G1899-1-HP-X-1-060720	Rev 1
Date: Tuesday, February 27, 2007	Sheet	1 of 1

6.3 Key Board

ESD by jc chen
2006/5/11

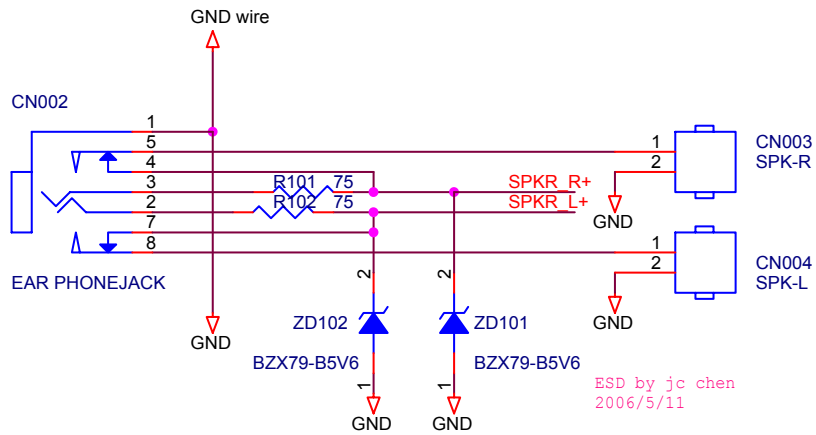

ESD by jc chen
2006/5/11

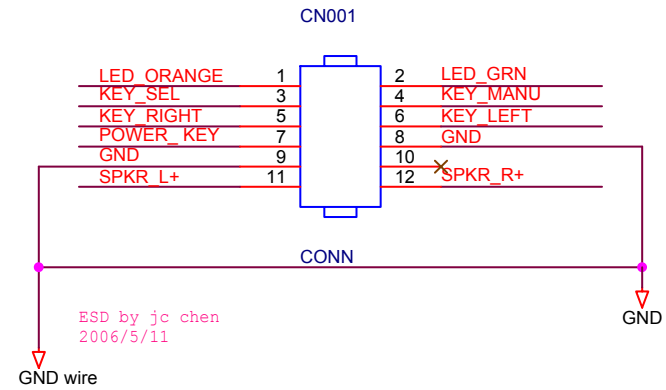
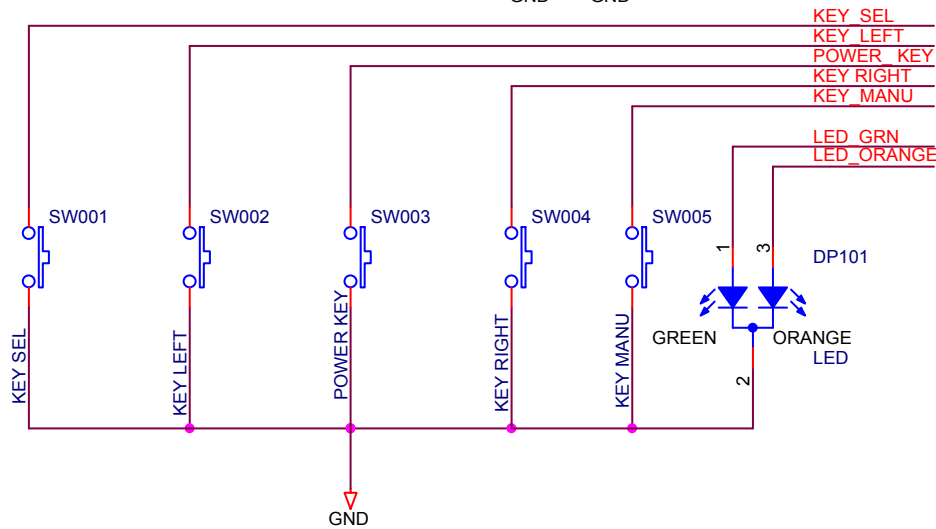

ESD by jc chen
2006/5/11

<i>AOC (Top Victory) Electronics Co., Ltd.</i>		
Title		
Size A	Document Number 715G2127-1	Rev c
Date: Tuesday, June 13, 2006	Sheet 1 of 1	

6.4 Audio Board

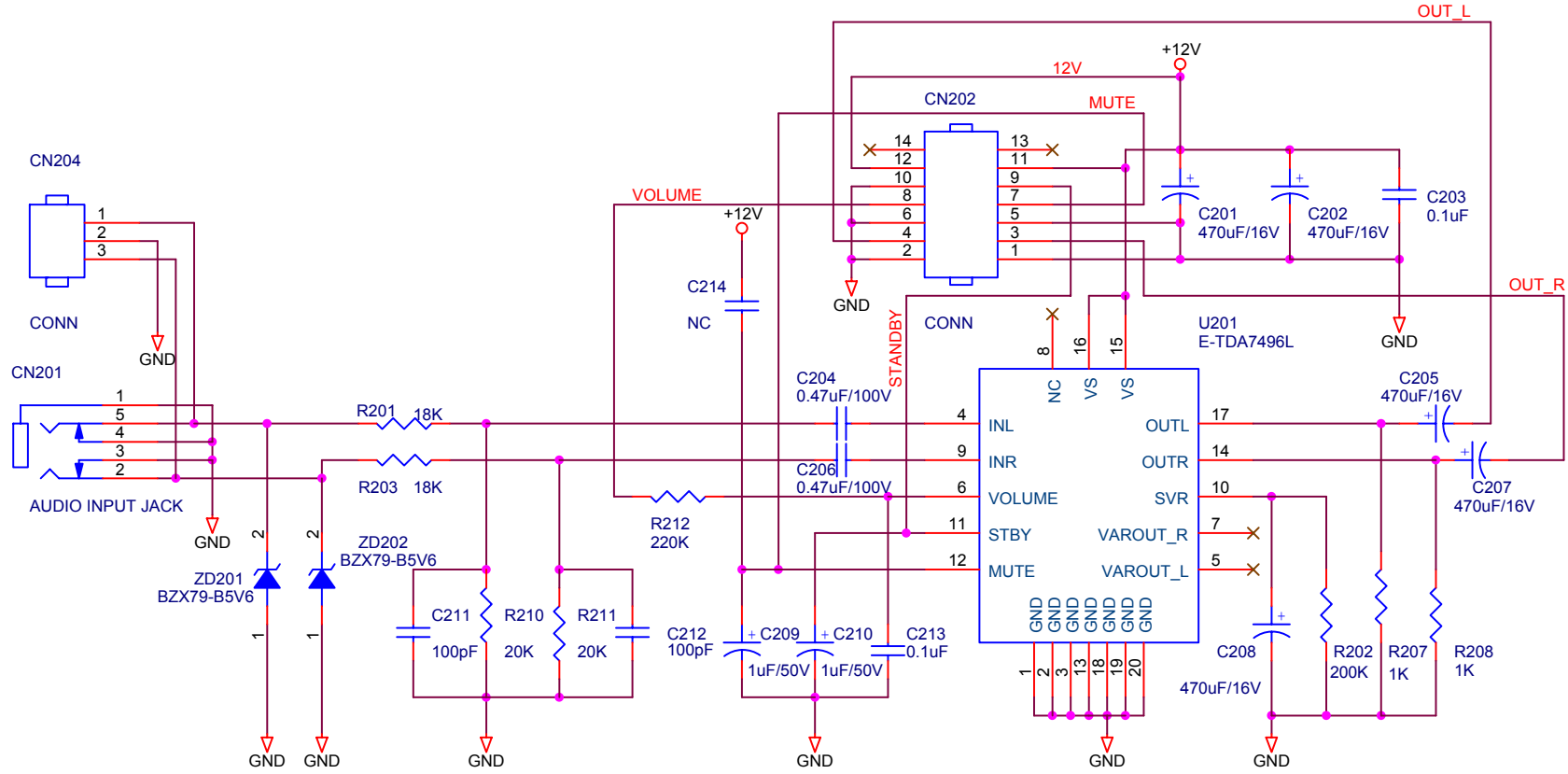

Title		
Size	Document Number	Rev
A	<Doc> 715G2128-1	1
Date:	Tuesday, June 13, 2006	Sheet 1 of 1

7. PCB Layout

7.1 Main Board

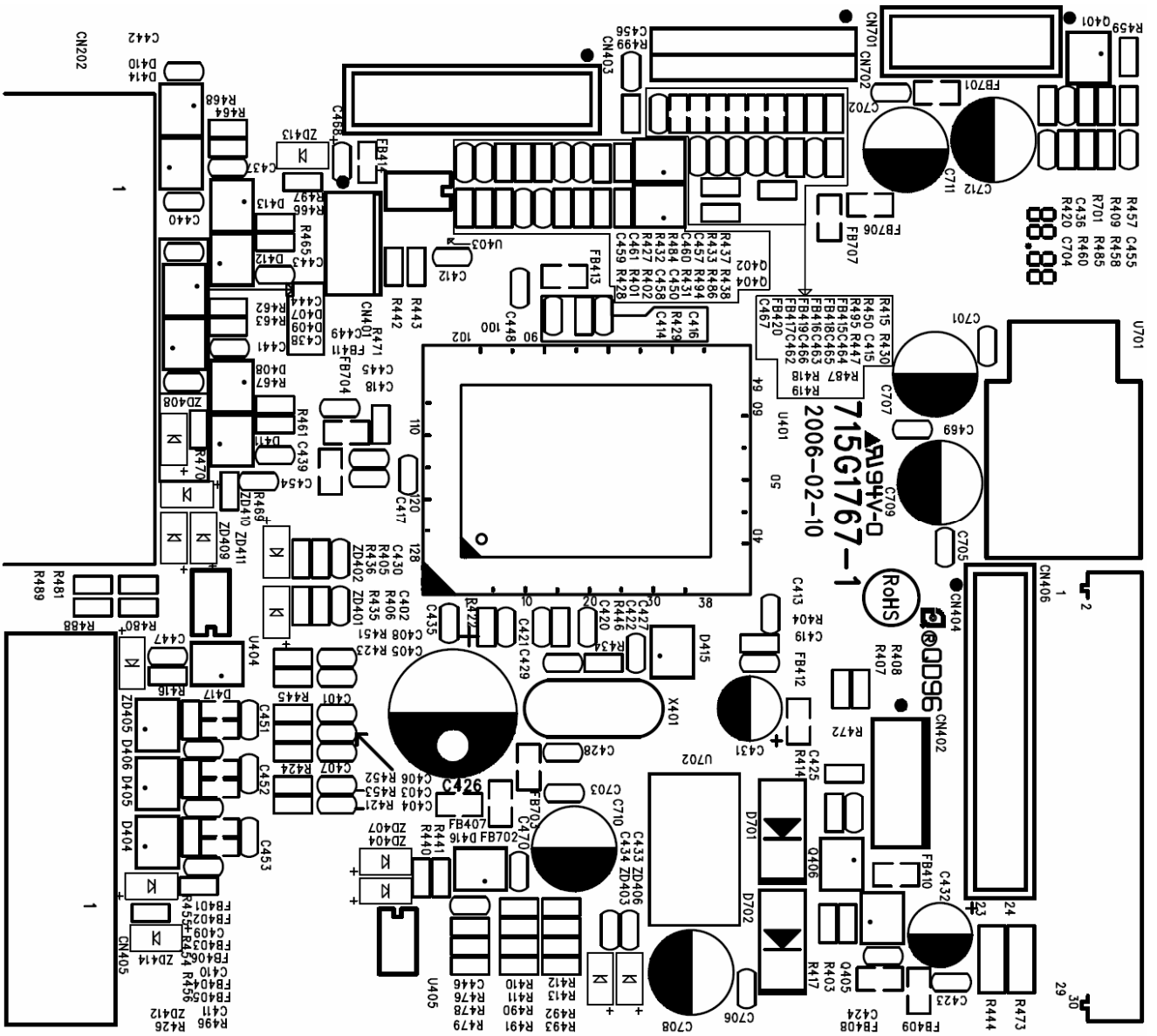

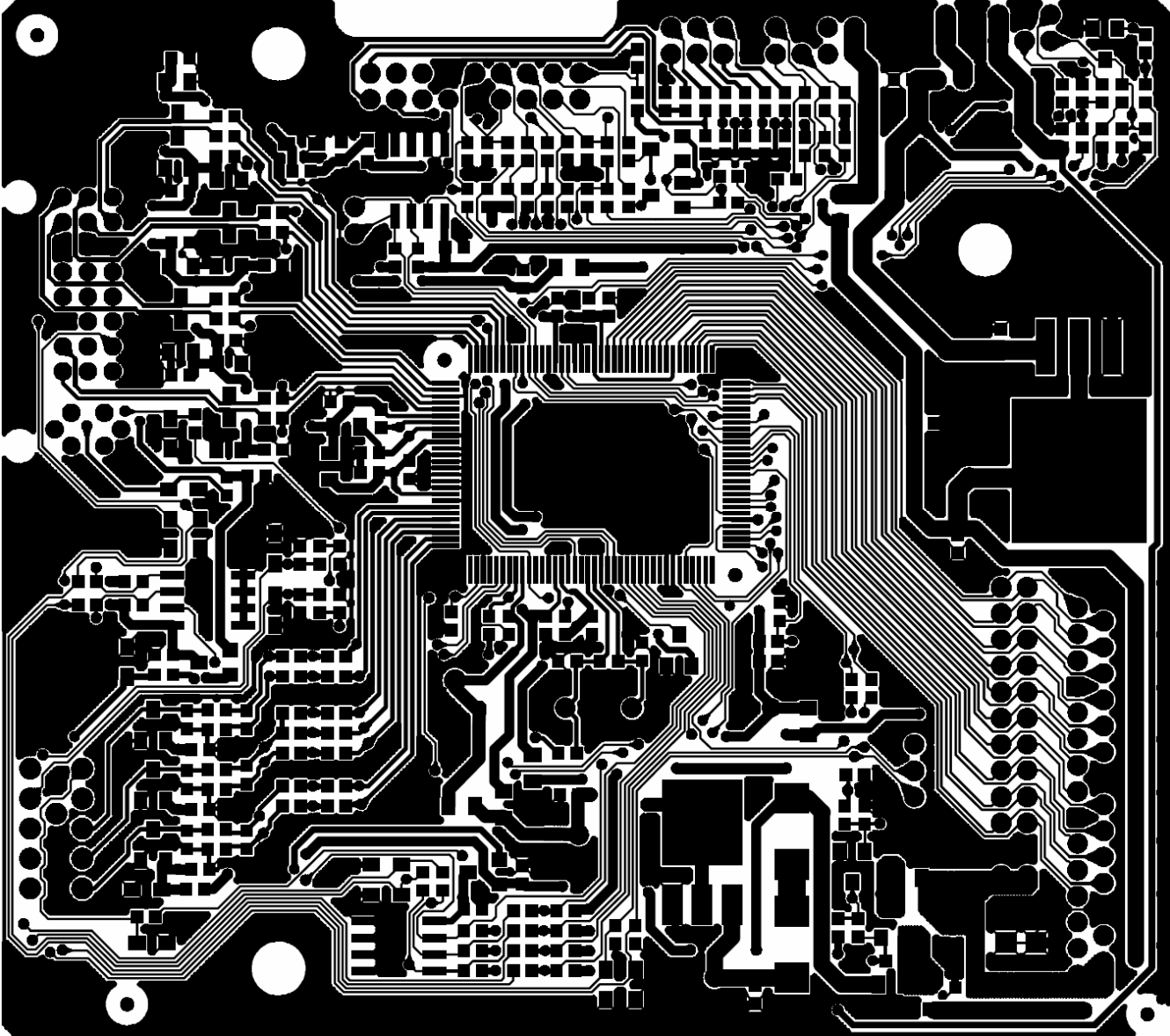

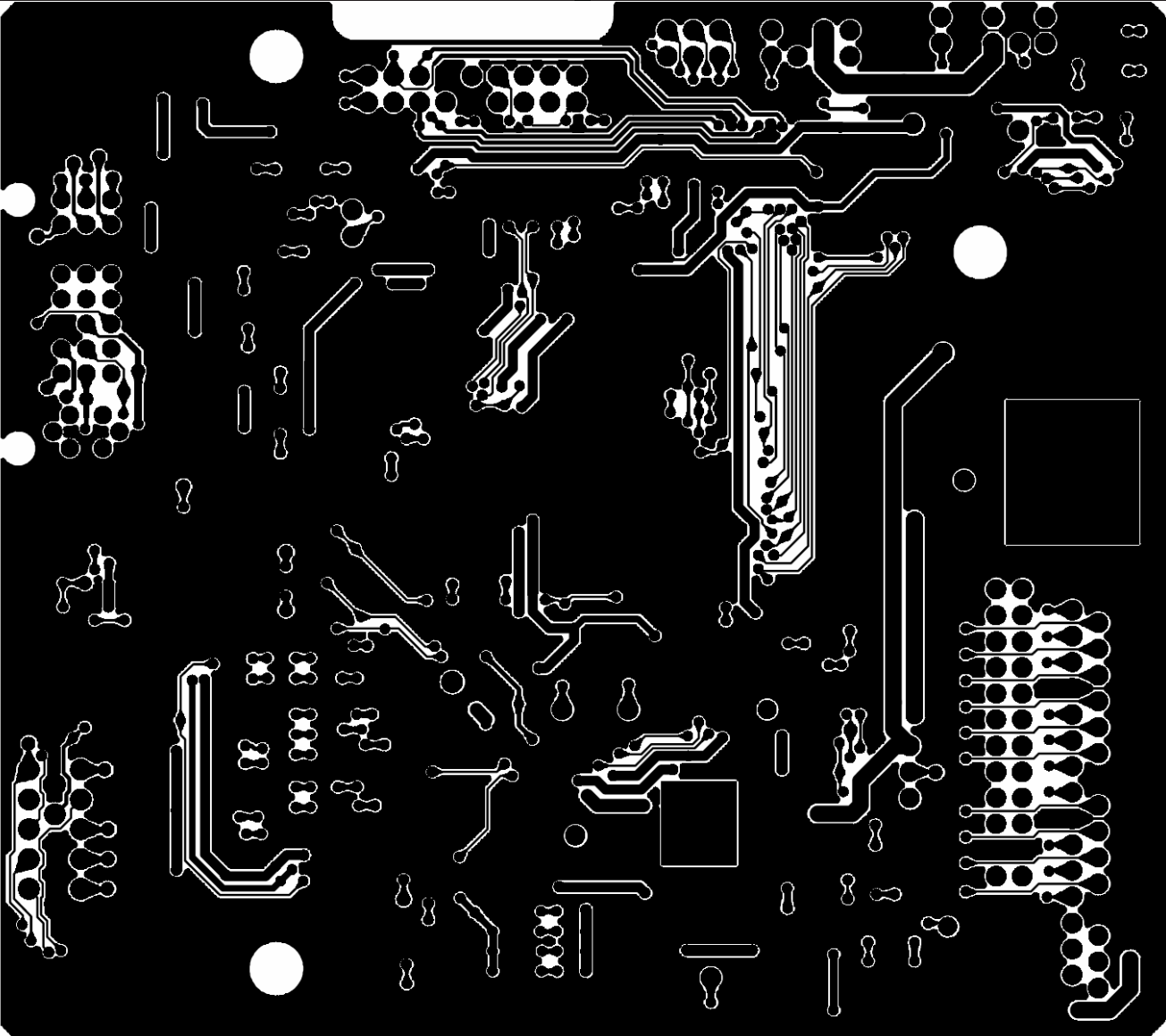

7.2 Power Board

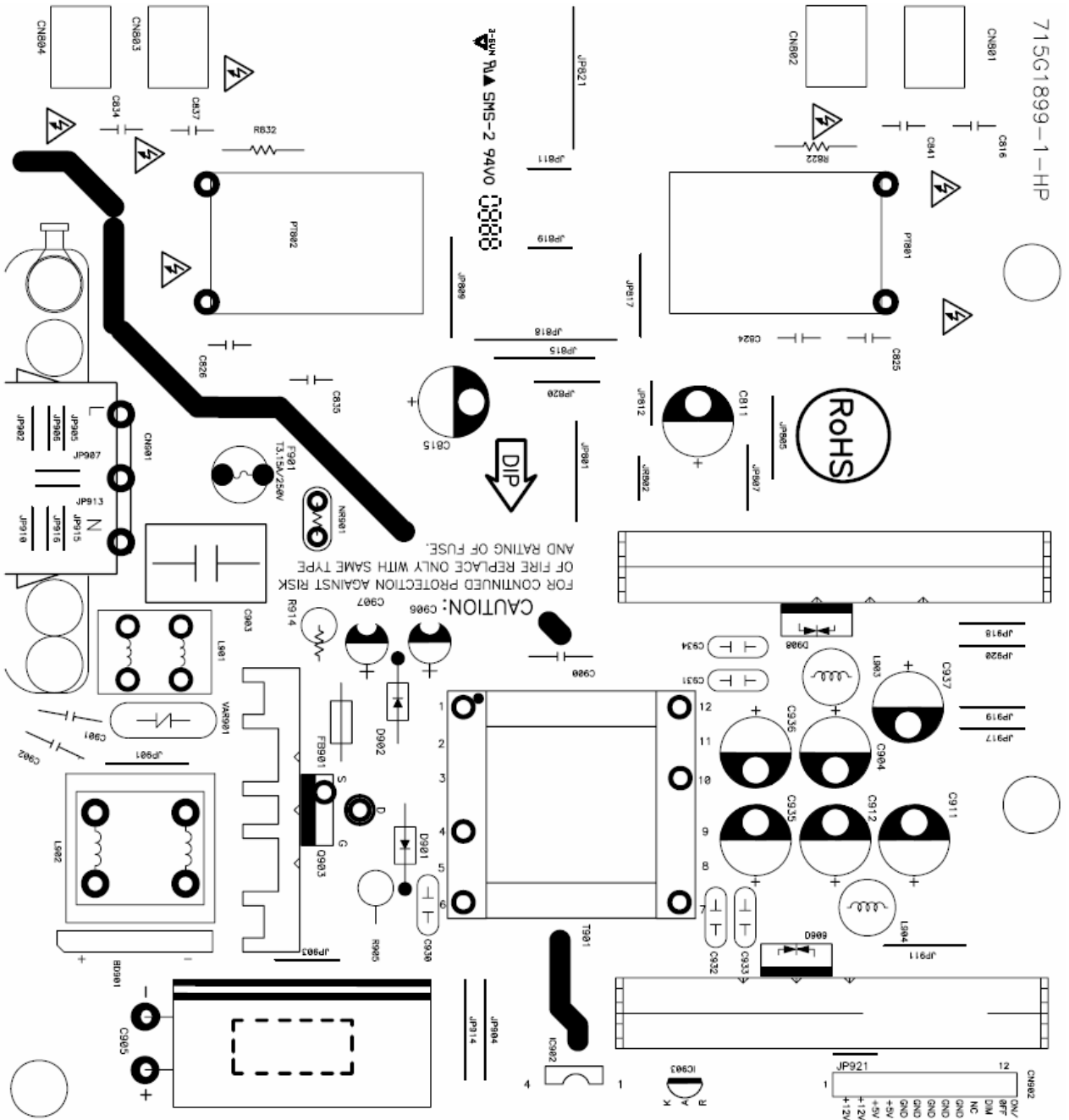

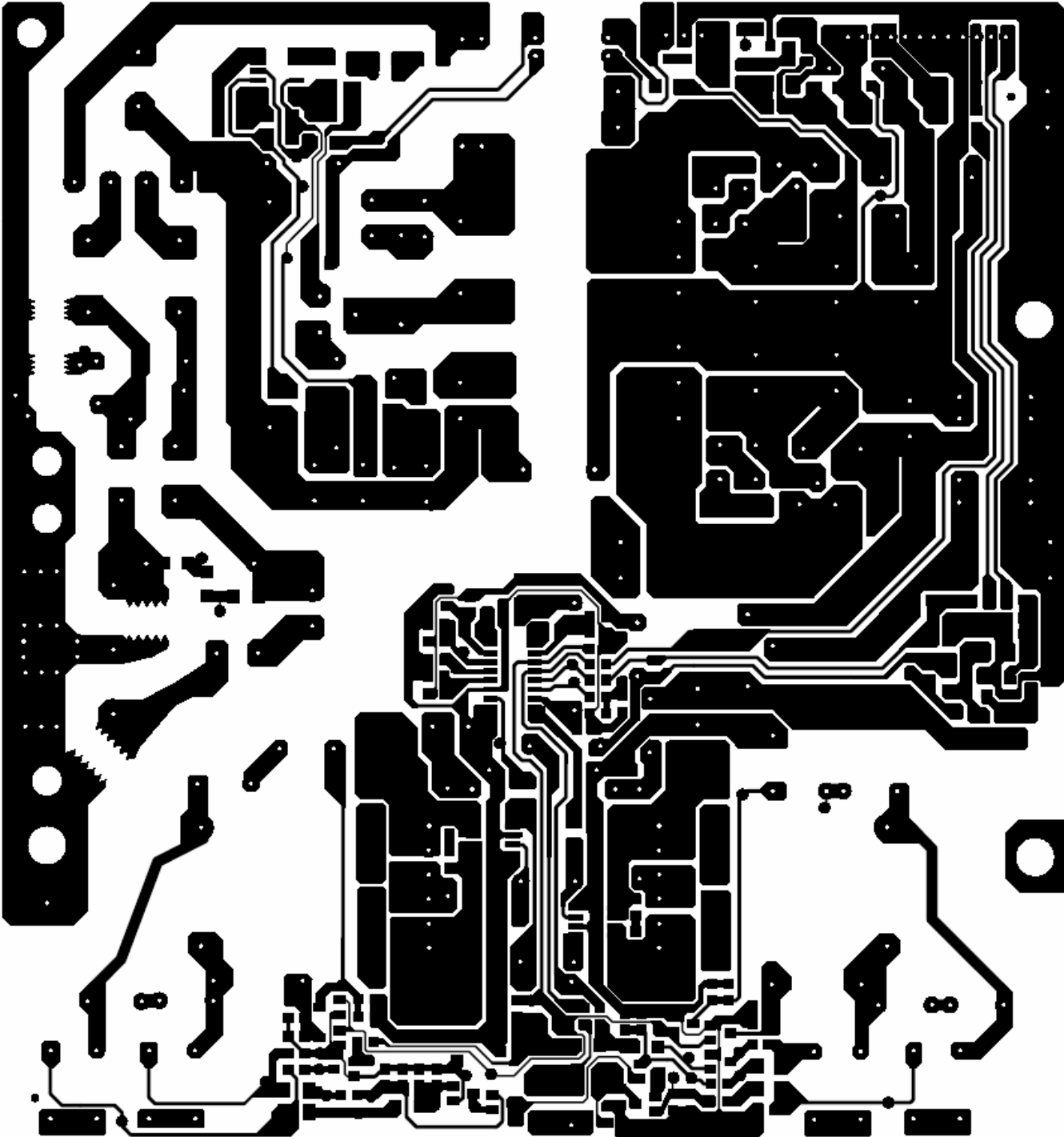

7.3 Key Board

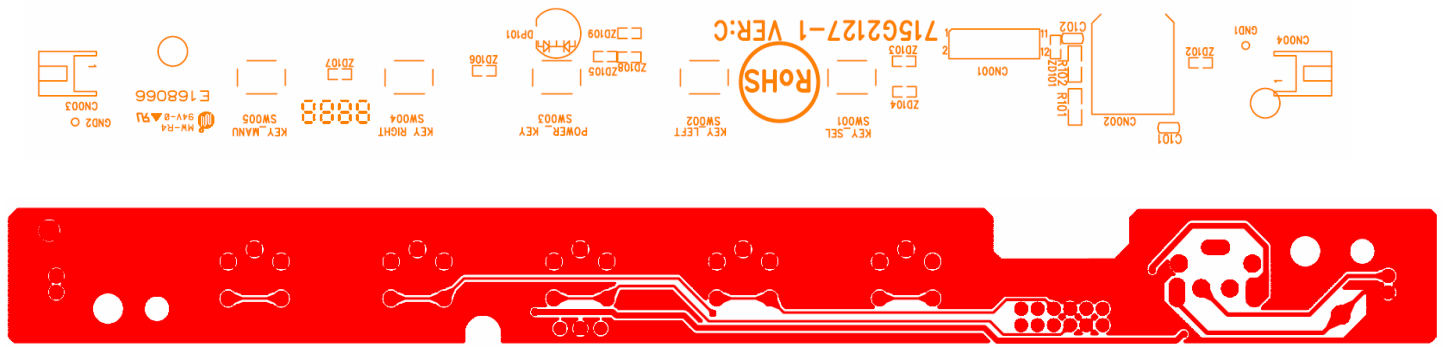

7.4 Audio Board

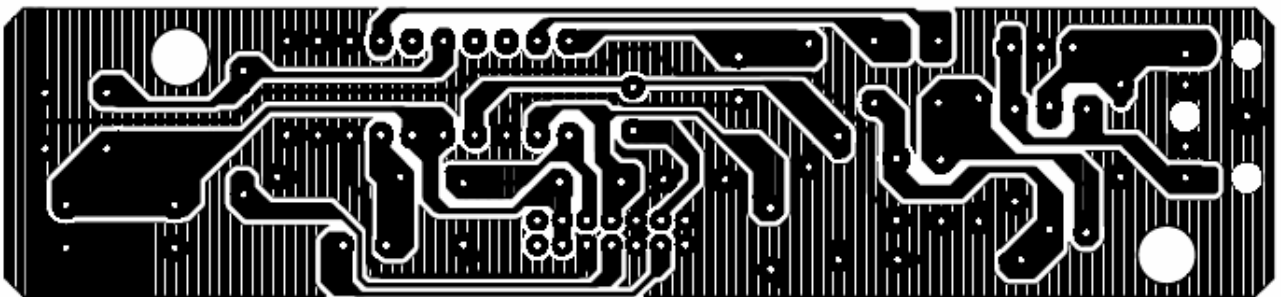
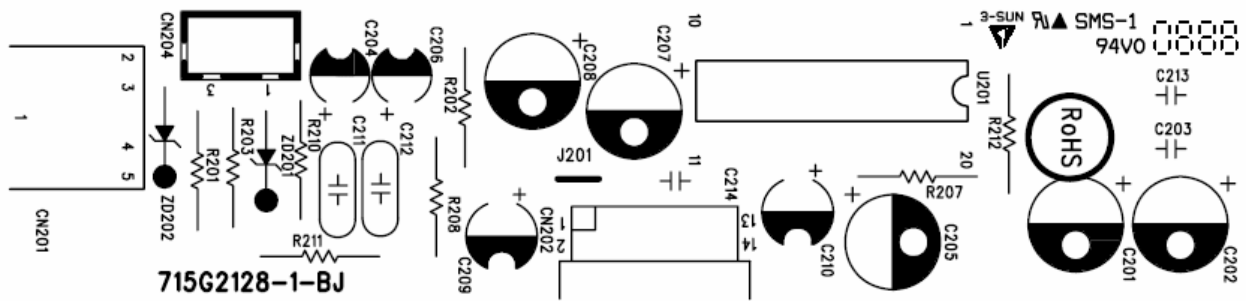

8. Maintainability

8.1 Equipments and Tools Requirement

1. Voltmeter.
2. Oscilloscope.
3. Pattern Generator.
4. DDC Tool with an IBM Compatible Computer.
5. Alignment Tool.
6. LCD Color Analyzer.
7. Service Manual.
8. User Manual.

8.2 Trouble Shooting

8.2.1 Main Board

(1) No Power

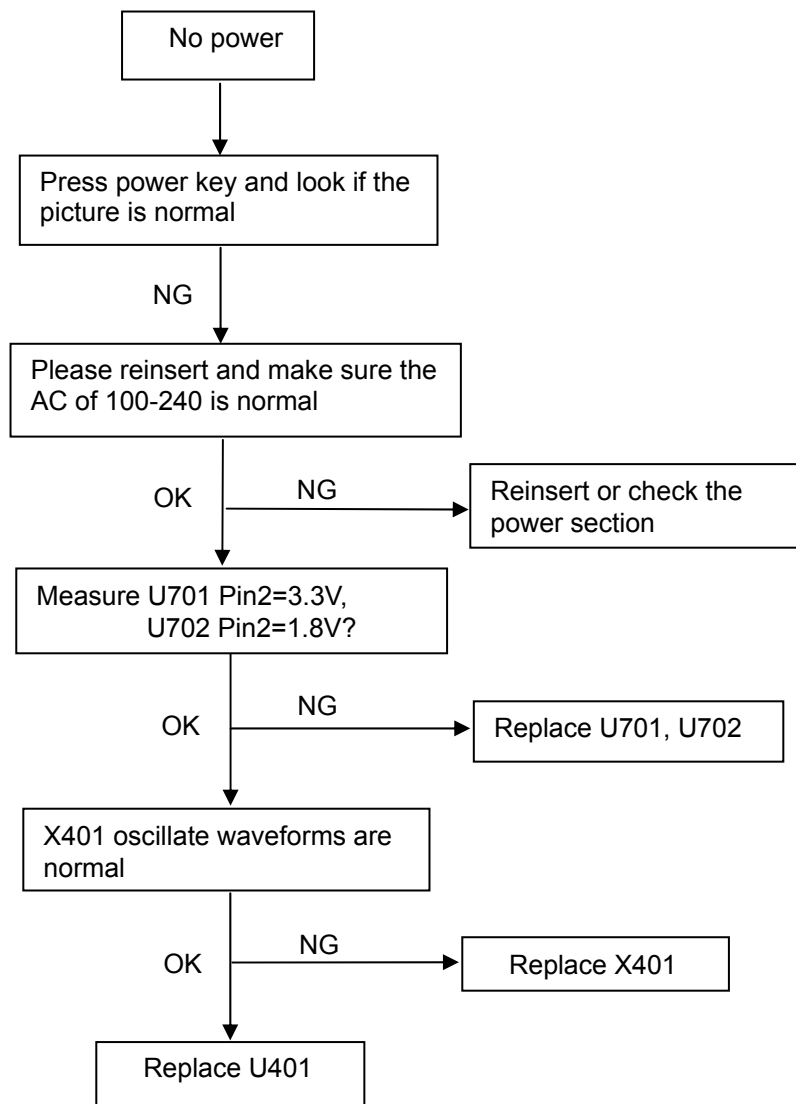

(2). No Picture

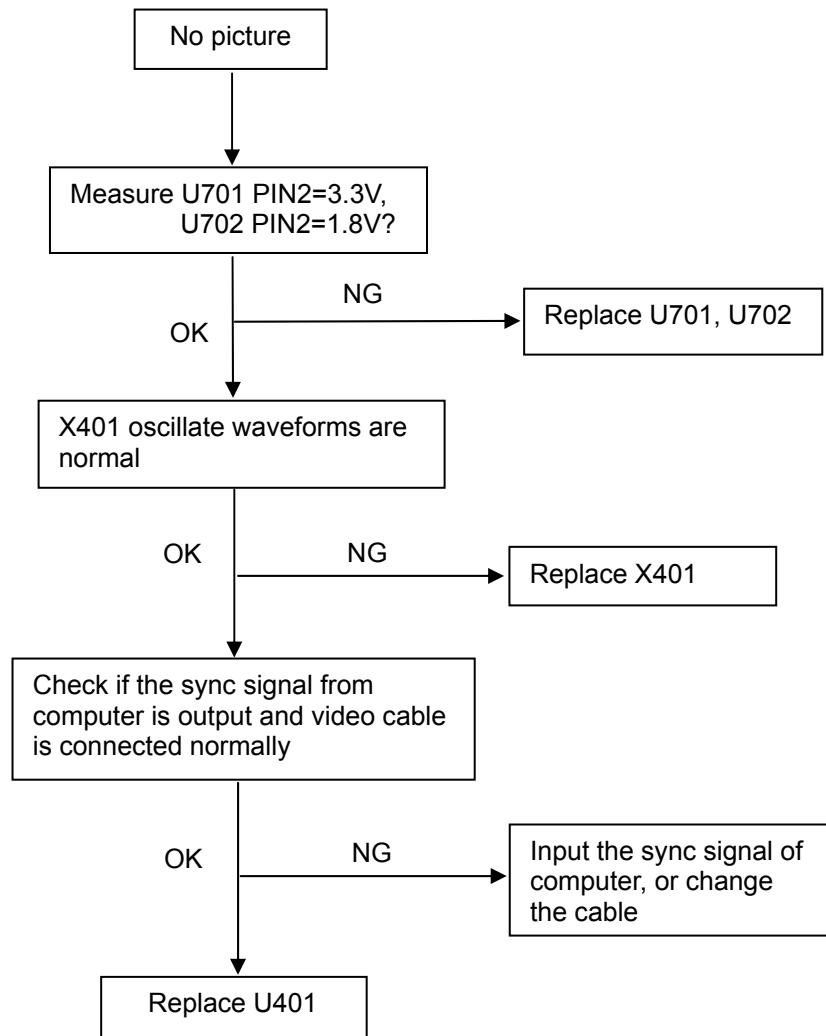

(3). White screen

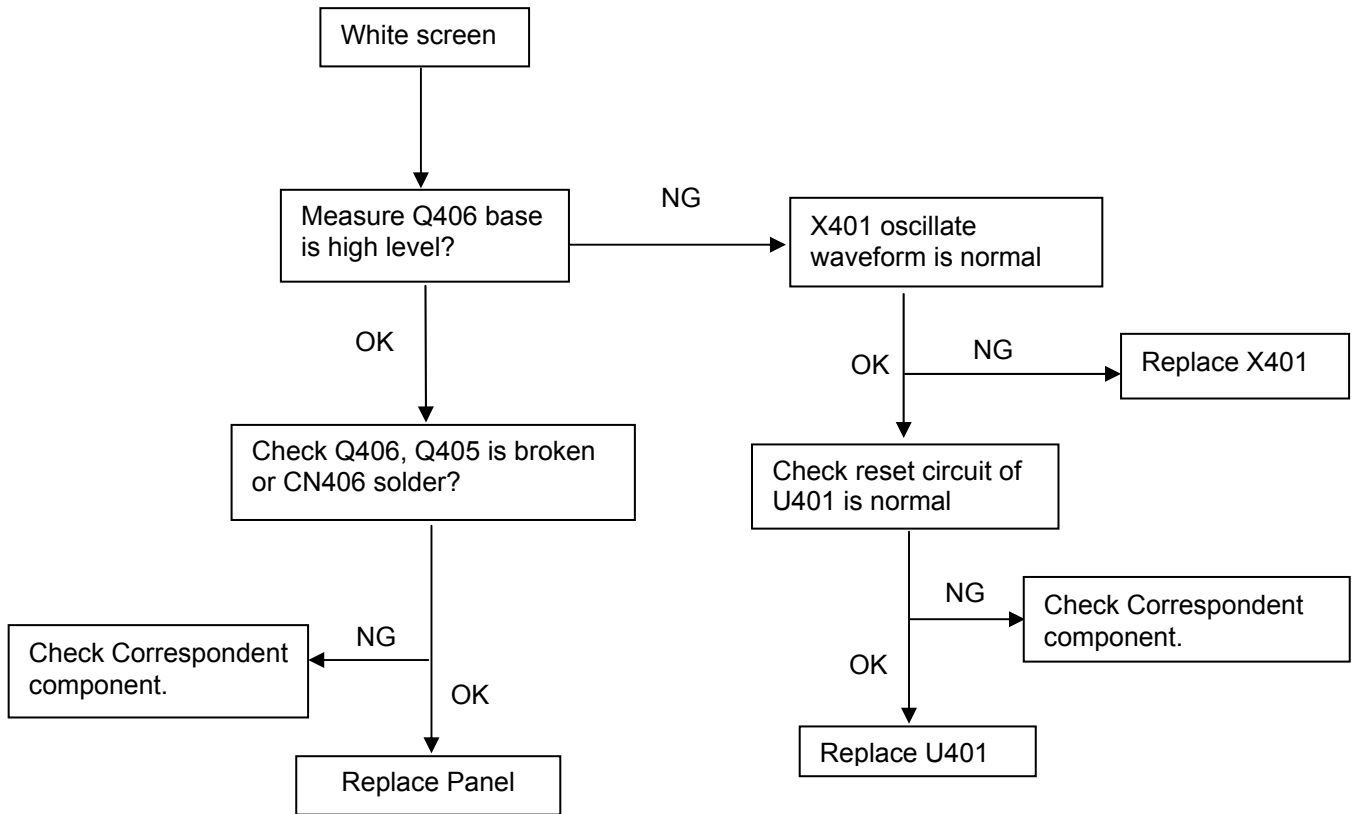

8.2.2 Power Board

1. No Power

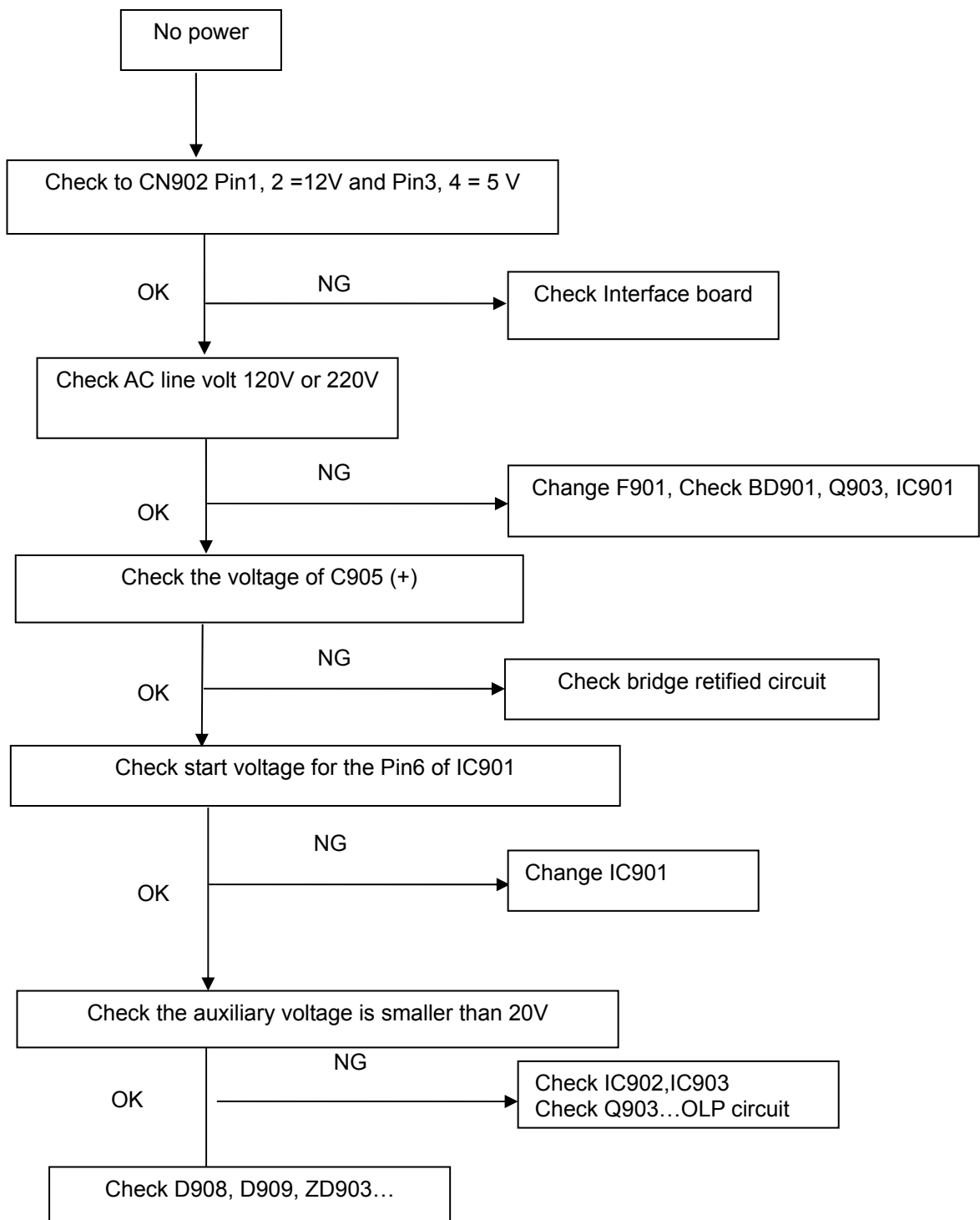

2. W/LED No Backlight

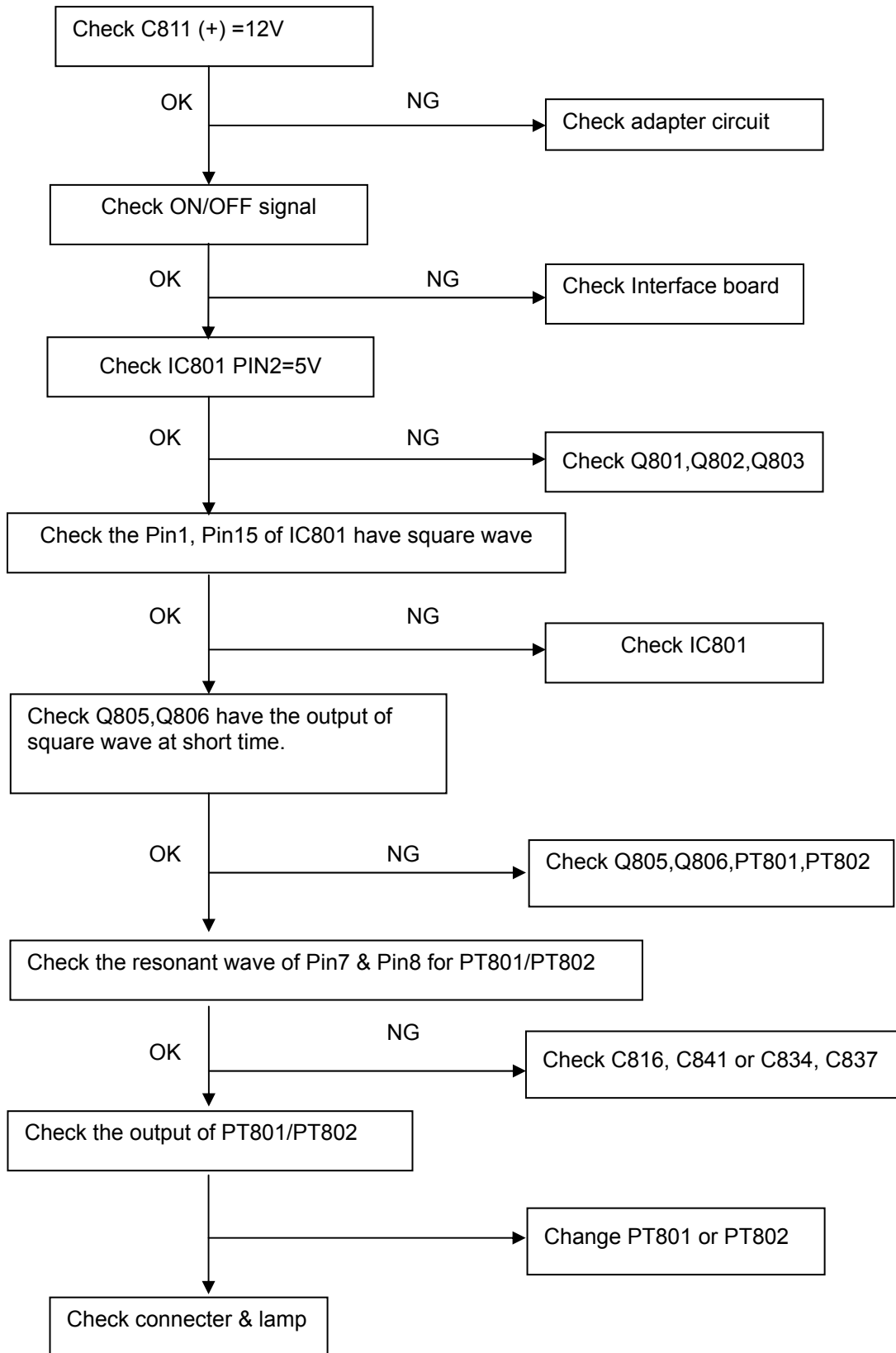

8.2.3 Key Board

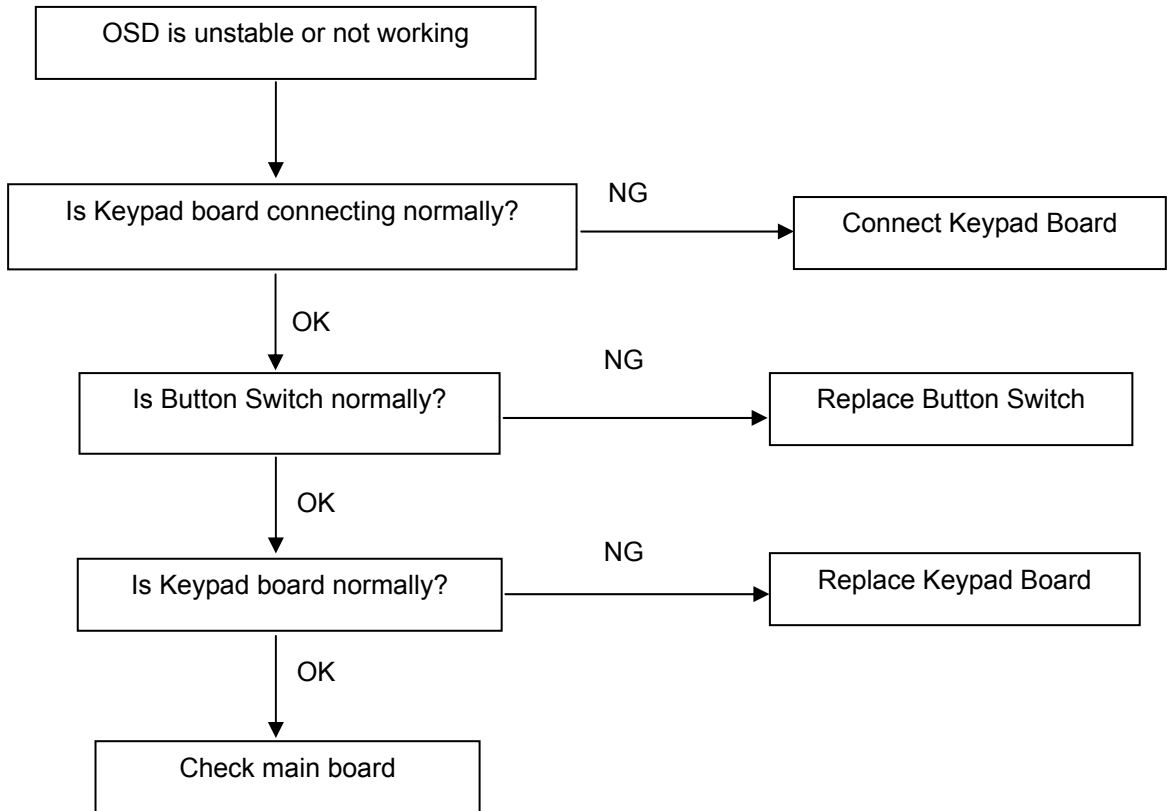

9. White- Balance, Luminance Adjustment

Approximately 30 minutes should be allowed for warm up before proceeding White-Balance adjustment.

1. How to do the Chroma-7120 MEM. Channel setting

A. Reference to chroma 7120 user guide

B. Use "SC" key and "NEXT" key to modify xyY value and use "ID" key to modify the TEXT description Following is the procedure to do white-balance adjust

2. Setting the color temp. you want

A. MEM.CHANNEL 3 cool (7800K color):

7800K color temp. parameter is $x = 296 \pm 20$, $y = 311 \pm 20$, $Y = 180 \text{ cd/m}^2$.

B. MEM.CHANNEL 4 warm (6500K color):

6500K color temp. parameter is $x = 313 \pm 20$, $y = 329 \pm 20$, $Y = 180 \text{ cd/m}^2$.

3. Into factory mode

Turn on power, press the MENU button, pull out the power cord, and then plug the power cord. Then the factory OSD will be at the left top of the panel.

4. Bias adjustment:

Set the **Contrast**  to 50; Adjust the **Brightness**  to 80.

5. Gain adjustment:

Move cursor to "-F-" and press MENU key

A. Adjust 7800K color-temperature

1. Switch the Chroma-7120 to **RGB-Mode** (with press "MODE" button)
2. Switch the MEM. Channel to Channel 3 (with up or down arrow on chroma 7120)
3. The LCD-indicator on chroma 7120 will show $x = 296 \pm 20$, $y = 311 \pm 20$, $Y = 180 \text{ cd/m}^2$
4. Adjust the RED of color1 on factory window until chroma 7120 indicator reached the value $R=100$
5. Adjust the GREEN of color1 on factory window until chroma 7120 indicator reached the value $G=100$
6. Adjust the BLUE of color1 on factory window until chroma 7120 indicator reached the value $B=100$
7. Repeat above procedure (item 4,5,6) until chroma 7120 RGB value meet the tolerance $=100 \pm 2$

B. Adjust 6500K color-temperature

1. Switch the chroma-7120 to **RGB-Mode** (with press "MODE" button)
2. Switch the MEM.channel to Channel 4 (with up or down arrow on chroma 7120)
3. The LCD-indicator on chroma 7120 will show $x = 313 \pm 20$, $y = 329 \pm 20$, $Y = 180 \text{ cd/m}^2$
4. Adjust the RED of color3 on factory window until chroma 7120 indicator reached the value $R=100$
5. Adjust the GREEN of color3 on factory window until chroma 7120 indicator reached the value $G=100$
6. Adjust the BLUE of color3 on factory window until chroma 7120 indicator reached the value $B=100$
7. Repeat above procedure (item 4,5,6) until chroma 7120 RGB value meet the tolerance $=100 \pm 2$

Turn the Power-button off to quit from factory mode.

10. Monitor Exploded View

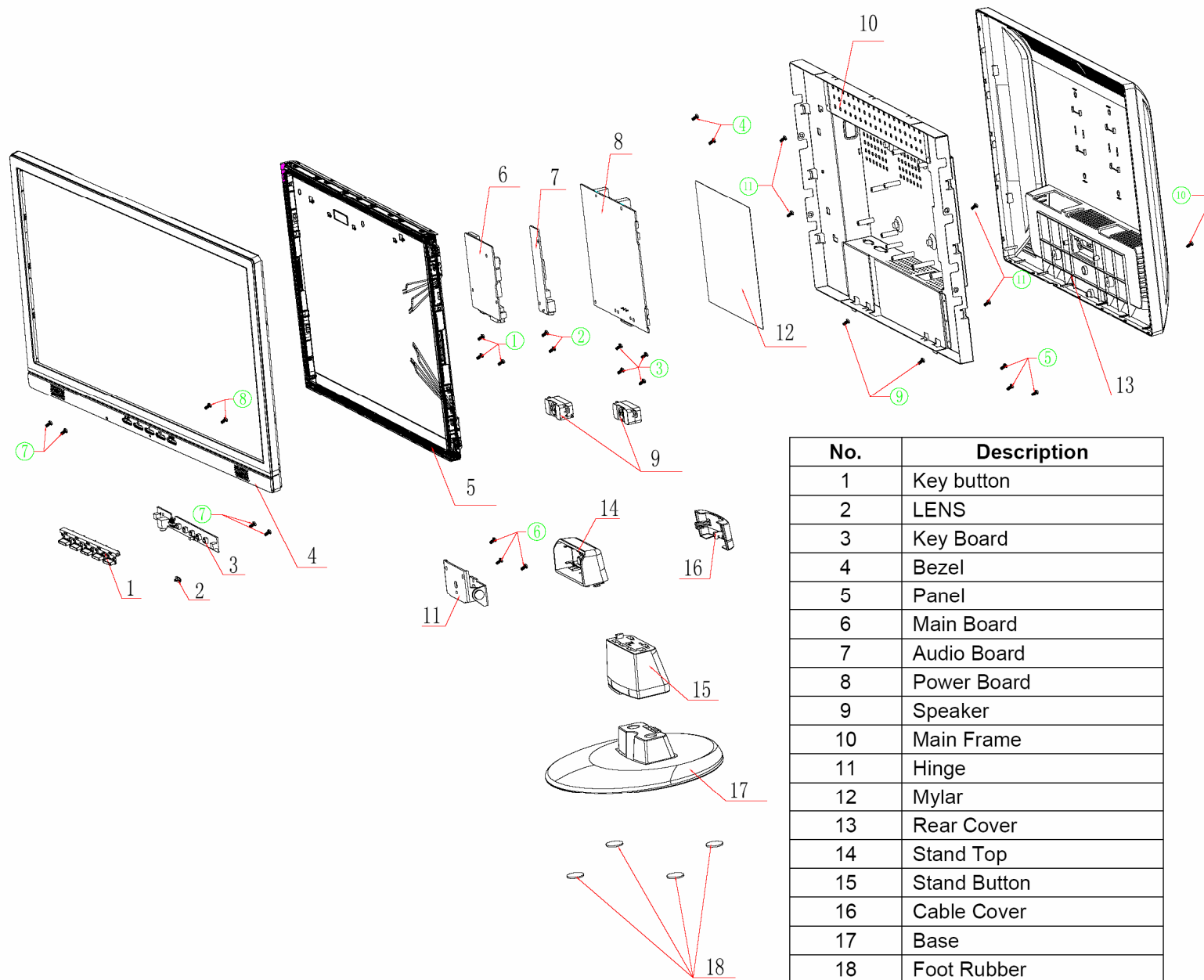

No.	Description
1	Key button
2	LENS
3	Key Board
4	Bezel
5	Panel
6	Main Board
7	Audio Board
8	Power Board
9	Speaker
10	Main Frame
11	Hinge
12	Mylar
13	Rear Cover
14	Stand Top
15	Stand Button
16	Cable Cover
17	Base
18	Foot Rubber

11. BOM List**T96HNNNQWCA08P**

Location	Part No.	Description
	026G 800504 3	BARCODE LABEL
	040G 154501 1	HI-POT GND LABEL
	041G780061591A	WARRANTY CARD
	044G6000 4 6B	PAPER BOARD
	044G6000757 1A	CARTON
	044G6002615 1A	PAPER BOARD
	044G6002695 3A	PAPER BOARD
	045G 76 28CK2	PE BAG
	045G 77500	BARCODE RIBBON
	045G 77501	BARCODE RIBBON
	045G 88525 B	PE BAG
	045G 88609 21	EPE COVER
	052G 1174 2A	3M 69#
	052G 1185	MIDDLE TAPE
	052G 1185 1	BIG TAPE
	052G 1186	SMALL TAPE
	052G 1191	GLASS CLOTH
	052G 1192	GLASS CLOTH
	052G 1207 A	ALUMINIUM TAPE
E078L	078G 322501 L	SPEAKER
E078L	078G 322501 KL	SPEAKER
E078L	078G 322501 YL	SPK 8OHM 1.5W SU
E078R	078G 322502 R	SPEAKER
E078R	078G 322502 KR	SPK 8OHM 1.5W KUAIDA
E078R	078G 322502 YR	SPK 8OHM 1.5W SU
	089G 173 56 4B	AUDIO CABLE
E089A	089G 715GAA D2	SIGNAL CABLE D-SUB GREATLAND
E089A	089G 715HAA D2	SIGNAL CABLE
	089G1745GAADVI	SIGNAL CABLE
	089G179J30H557	FFC CABLE
	089G402A15NIS1	POWER CORD
	095G8014 14671 D	WIRE HARNESS
	095G801416XH04	WIRE HARNESS
	0M1G 340 8225 CR3	SCREW
	0M1G1140 6128 CR3	SCREW
	0M1G1730 6128 CR3	SCREW
	0M1G1730 6128 CR3	SCREW
	0M1G1730 6128 CR3	SCREW
	0M1G2430 5225 CR3	SCREW
	0Q1G 330 8120	SCREW 3X8MM
	0Q1G 330 8120	SCREW 3X8MM
	0Q1G 330 12 47 CR3	SCREW
	705GQ9K0F34050	19" LCD BEZEL ASS'Y
	0Q1G1030 8128 CR3	SCREW
	A33G0072 GM 1L	KEY PAD
	A33G0074 1 1C	POWER LENS

	A34G0052 A5A3L	BEZEL(19")
	705GQ9K0P34050	19" LCD STAND COVER-BASE ASS'Y
	012G 394 3	RUBBER FOOT
	A34G0053 GM 1L	STAND TOP
	A34G0054 A5 1L	STAND BOTTOM
	A34G0097 A5 1L 20	BASE
	AQ1G1740 12120	SCREW
	Q37G0041 1	HINGE
E750L	750GLH90GW111N	PANEL LCD 19" MGW1 A00 HSD
E750L	750GLH90GW112N	PANEL LCD HSD190MGW1 A00 HSD
M01	A15G0032 3CKD	MAIN FRAME
	A33G0030 GM 1L 32	CABLE COVER
	A34G0051 GMA1L	REAR COVER(19")
	AUPC6QA6QP8	AUDIO BOARD
CN202	033G8027 14	WAFER 14P 2.0MM DIP DUAL ROW
U201	056G 616 1	IC E-TDA7496L ST
C204	067G 70478 9T	0.47UF +-20% 100V
C206	067G 70478 9T	0.47UF +-20% 100V
C210	067G 2151007NT	KY50VB10M-TP5 5*11.5
C201	067G215B471 3N GP	KY16VB470M-L 8*15MM
C202	067G215B471 3N GP	KY16VB470M-L 8*15MM
C205	067G215B471 3N GP	KY16VB470M-L 8*15MM
C207	067G215B471 3N GP	KY16VB470M-L 8*15MM
C208	067G215B471 3N GP	KY16VB470M-L 8*15MM
CN201	088G 30229C	PHONE JACK
CN201	088G 30229T TN	PHONE JACK 5PIN BLUE
	090G6059 1	HEAT SINK
R207	061G 60210252T	CFR 1K OHM +-5% 1/6W
R208	061G 60210252T	CFR 1K OHM +-5% 1/6W
R201	061G 60218352T	18KOHM 5% 1/6
R203	061G 60218352T	18KOHM 5% 1/6
R211	061G 60220352T	CFR 20K OHM+-5% 1/6W
R210	061G 60220352T	CFR 20K OHM+-5% 1/6W
R202	061G 60220452T	200KOHM 5% 1/6W
R212	061G 60222452T	220KOHM 5% 1/6W
C211	065G 444101 5T	100 PF 10% 50V Y5P
C212	065G 444101 5T	100 PF 10% 50V Y5P
C214	065G 450104 7T	0.1UF +80-20% 50V Y5V
C213	065G 450104 7T	0.1UF +80-20% 50V Y5V
C203	065G 450104 7T	0.1UF +80-20% 50V Y5V
	715G2128 1 BJ	AUDIO BOARD PCB
	CBPC6HNNNNQP8	CONVERSION BOARD FOR 19"
CN406	033G801930F H	FPC CONN. 1.0MM 30P
CN701	033G8027 12	WAFER 2*6P 2.0MM R/A
CN702	033G8027 14	WAFER 14P 2.0MM DIP DUAL ROW
CN403	033G8027 16	WAFER 16PIN 2.0MM DIP
	040G 457624 1B	LABEL-CPU
	040G 45762412B	CBPC LABEL
C707	067G215L101 4N	KY25VB100M-L 6.3*11
C708	067G215L101 4N	KY25VB100M-L 6.3*11
C709	067G215L101 4N	KY25VB100M-L 6.3*11

C710	067G215L101 4N	KY25VB100M-L 6.3*11
C711	067G215L101 4N	KY25VB100M-L 6.3*11
C712	067G215L101 4N	KY25VB100M-L 6.3*11
C426	067G215L471 3N	KY16VB470M-L 10*12.5
C431	067G215V470 4N	KY25VB47-M-CC3.0 5*11MM
C432	067G215Y479 7N	LOW ESR EC 4.7 UF 50V NC
CN405	088G 35315F H	D-SUB 15PIN
CN405	088G 35315F HJ	SOC SUBD H 15P F
CN202	088G 35424F H	DVI CONNECTOR 24PIN
X401	093G 22 51	CRYSTAL 12MHZ HC-49US ARG6-120
U401	056G 562913 G	IC NT68663MEFG-64/G NOVATEK
U701	056G 563 7	IC AIC1084-33PMTR-R AIC
U701	056G 563 21	AP1084K33LA
U702	056G 563 31	AI1117D-1.8-EI
U403	056G1133 24	AT24C16AN-10SU-2.7
U405	056G1133 34	M24C02-WMN6TP
U404	056G1133 34	M24C02-WMN6TP
Q406	057G 417 4	PMBS3904/PHILIPS-SMT(04)
Q401	057G 417 4	PMBS3904/PHILIPS-SMT(04)
Q404	057G 417 13 T	KEC 2N3906S-RTK/PS
Q402	057G 417 13 T	KEC 2N3906S-RTK/PS
Q405	057G 763 1	A03401 SOT23 BY AOS(A1)
FB402	061G0603000	RST CHIPR 0 OHM +-5% 1/10W
FB405	061G0603000	RST CHIPR 0 OHM +-5% 1/10W
FB406	061G0603000	RST CHIPR 0 OHM +-5% 1/10W
R410	061G0603000	RST CHIPR 0 OHM +-5% 1/10W
R411	061G0603000	RST CHIPR 0 OHM +-5% 1/10W
R416	061G0603000	RST CHIPR 0 OHM +-5% 1/10W
R450	061G0603000	RST CHIPR 0 OHM +-5% 1/10W
R457	061G0603000	RST CHIPR 0 OHM +-5% 1/10W
R461	061G0603000	RST CHIPR 0 OHM +-5% 1/10W
R462	061G0603000	RST CHIPR 0 OHM +-5% 1/10W
R463	061G0603000	RST CHIPR 0 OHM +-5% 1/10W
R464	061G0603000	RST CHIPR 0 OHM +-5% 1/10W
R465	061G0603000	RST CHIPR 0 OHM +-5% 1/10W
R466	061G0603000	RST CHIPR 0 OHM +-5% 1/10W
R467	061G0603000	RST CHIPR 0 OHM +-5% 1/10W
R468	061G0603000	RST CHIPR 0 OHM +-5% 1/10W
R499	061G0603000	RST CHIPR 0 OHM +-5% 1/10W
R495	061G0603000	RST CHIPR 0 OHM +-5% 1/10W
R494	061G0603000	RST CHIPR 0 OHM +-5% 1/10W
R491	061G0603000	RST CHIPR 0 OHM +-5% 1/10W
R490	061G0603000	RST CHIPR 0 OHM +-5% 1/10W
R440	061G0603101	RST CHIPR 100 OHM +-5% 1/10W
R441	061G0603101	RST CHIPR 100 OHM +-5% 1/10W
R451	061G0603101	RST CHIPR 100 OHM +-5% 1/10W
R452	061G0603101	RST CHIPR 100 OHM +-5% 1/10W
R453	061G0603101	RST CHIPR 100 OHM +-5% 1/10W
R488	061G0603101	RST CHIPR 100 OHM +-5% 1/10W
R489	061G0603101	RST CHIPR 100 OHM +-5% 1/10W
R405	061G0603101	RST CHIPR 100 OHM +-5% 1/10W

R406	061G0603101	RST CHIPR 100 OHM +-5% 1/10W
R407	061G0603101	RST CHIPR 100 OHM +-5% 1/10W
R408	061G0603101	RST CHIPR 100 OHM +-5% 1/10W
R497	061G0603102	RST CHIP 1K 1/10W 5%
R496	061G0603102	RST CHIP 1K 1/10W 5%
R484	061G0603102	RST CHIP 1K 1/10W 5%
R420	061G0603102	RST CHIP 1K 1/10W 5%
R422	061G0603102	RST CHIP 1K 1/10W 5%
R426	061G0603102	RST CHIP 1K 1/10W 5%
R427	061G0603102	RST CHIP 1K 1/10W 5%
R428	061G0603102	RST CHIP 1K 1/10W 5%
R431	061G0603102	RST CHIP 1K 1/10W 5%
R432	061G0603102	RST CHIP 1K 1/10W 5%
R433	061G0603102	RST CHIP 1K 1/10W 5%
R470	061G0603102	RST CHIP 1K 1/10W 5%
R401	061G0603103	RST CHIPR 10 KOHM +-5% 1/10W
R476	061G0603103	RST CHIPR 10 KOHM +-5% 1/10W
R472	061G0603103	RST CHIPR 10 KOHM +-5% 1/10W
R469	061G0603103	RST CHIPR 10 KOHM +-5% 1/10W
R459	061G0603103	RST CHIPR 10 KOHM +-5% 1/10W
R458	061G0603103	RST CHIPR 10 KOHM +-5% 1/10W
R446	061G0603103	RST CHIPR 10 KOHM +-5% 1/10W
R430	061G0603103	RST CHIPR 10 KOHM +-5% 1/10W
R419	061G0603103	RST CHIPR 10 KOHM +-5% 1/10W
R418	061G0603103	RST CHIPR 10 KOHM +-5% 1/10W
R417	061G0603103	RST CHIPR 10 KOHM +-5% 1/10W
R415	061G0603103	RST CHIPR 10 KOHM +-5% 1/10W
R402	061G0603103	RST CHIPR 10 KOHM +-5% 1/10W
R414	061G0603104	RST CHIPR 100 KOHM +-5% 1/10W
R404	061G0603104	RST CHIPR 100 KOHM +-5% 1/10W
R403	061G0603104	RST CHIPR 100 KOHM +-5% 1/10W
R434	061G0603105	RST CHIPR 1 MOHM +-5% 1/10W
R424	061G0603151	RST CHIPR 150 OHM +-5% 1/10W
R423	061G0603151	RST CHIPR 150 OHM +-5% 1/10W
R421	061G0603151	RST CHIPR 150 OHM +-5% 1/10W
R436	061G0603222	RST CHIPR 2.2 KOHM +-5% 1/10W
R435	061G0603222	RST CHIPR 2.2 KOHM +-5% 1/10W
R438	061G0603332	RST CHIPR 3.3 KOHM +-5% 1/10W
R443	061G0603332	RST CHIPR 3.3 KOHM +-5% 1/10W
R442	061G0603332	RST CHIPR 3.3 KOHM +-5% 1/10W
R445	061G0603390 0F	RST CHIPR 390 OHM +-1% 1/10W
R471	061G0603390 0F	RST CHIPR 390 OHM +-1% 1/10W
R437	061G0603391	RST CHIPR 390 OHM +-5% 1/10W
R701	061G0603470	RST CHIPR 47 OHM +-5% 1/10W
R447	061G0603472	RST CHIPR 4.7KOHM +-5% 1/10W
R460	061G0603472	RST CHIPR 4.7KOHM +-5% 1/10W
R478	061G0603472	RST CHIPR 4.7KOHM +-5% 1/10W
R479	061G0603472	RST CHIPR 4.7KOHM +-5% 1/10W
R480	061G0603472	RST CHIPR 4.7KOHM +-5% 1/10W
R481	061G0603472	RST CHIPR 4.7KOHM +-5% 1/10W
R454	061G0603750	RST CHIPR 75 OHM +-5% 1/10W

R455	061G0603750	RST CHIPR 75 OHM +-5% 1/10W
R456	061G0603750	RST CHIPR 75 OHM +-5% 1/10W
R444	061G1206151	RST CHIPR 150 OHM +-5% 1/4W
R473	061G1206151	RST CHIPR 150 OHM +-5% 1/4W
C461	065G0603102 31	CHIP 1000PF 50V NPO
C458	065G0603102 31	CHIP 1000PF 50V NPO
C457	065G0603102 31	CHIP 1000PF 50V NPO
C456	065G0603102 31	CHIP 1000PF 50V NPO
C402	065G0603102 31	CHIP 1000PF 50V NPO
C464	065G0603102 31	CHIP 1000PF 50V NPO
C465	065G0603102 31	CHIP 1000PF 50V NPO
C466	065G0603102 31	CHIP 1000PF 50V NPO
C467	065G0603102 31	CHIP 1000PF 50V NPO
C468	065G0603102 31	CHIP 1000PF 50V NPO
C469	065G0603102 31	CHIP 1000PF 50V NPO
C470	065G0603102 31	CHIP 1000PF 50V NPO
C462	065G0603102 31	CHIP 1000PF 50V NPO
C463	065G0603102 31	CHIP 1000PF 50V NPO
C459	065G0603102 31	CHIP 1000PF 50V NPO
C460	065G0603102 31	CHIP 1000PF 50V NPO
C401	065G0603102 31	CHIP 1000PF 50V NPO
C441	065G0603104 12	CER2 0603 X7R 16V 100N P
C440	065G0603104 12	CER2 0603 X7R 16V 100N P
C439	065G0603104 12	CER2 0603 X7R 16V 100N P
C438	065G0603104 12	CER2 0603 X7R 16V 100N P
C437	065G0603104 12	CER2 0603 X7R 16V 100N P
C436	065G0603104 12	CER2 0603 X7R 16V 100N P
C425	065G0603104 12	CER2 0603 X7R 16V 100N P
C424	065G0603104 12	CER2 0603 X7R 16V 100N P
C423	065G0603104 12	CER2 0603 X7R 16V 100N P
C422	065G0603104 12	CER2 0603 X7R 16V 100N P
C421	065G0603104 12	CER2 0603 X7R 16V 100N P
C420	065G0603104 12	CER2 0603 X7R 16V 100N P
C701	065G0603104 12	CER2 0603 X7R 16V 100N P
C455	065G0603104 12	CER2 0603 X7R 16V 100N P
C454	065G0603104 12	CER2 0603 X7R 16V 100N P
C450	065G0603104 12	CER2 0603 X7R 16V 100N P
C449	065G0603104 12	CER2 0603 X7R 16V 100N P
C448	065G0603104 12	CER2 0603 X7R 16V 100N P
C447	065G0603104 12	CER2 0603 X7R 16V 100N P
C446	065G0603104 12	CER2 0603 X7R 16V 100N P
C445	065G0603104 12	CER2 0603 X7R 16V 100N P
C444	065G0603104 12	CER2 0603 X7R 16V 100N P
C443	065G0603104 12	CER2 0603 X7R 16V 100N P
C442	065G0603104 12	CER2 0603 X7R 16V 100N P
C419	065G0603104 12	CER2 0603 X7R 16V 100N P
C706	065G0603104 12	CER2 0603 X7R 16V 100N P
C705	065G0603104 12	CER2 0603 X7R 16V 100N P
C704	065G0603104 12	CER2 0603 X7R 16V 100N P
C703	065G0603104 12	CER2 0603 X7R 16V 100N P
C702	065G0603104 12	CER2 0603 X7R 16V 100N P

C409	065G0603104 12	CER2 0603 X7R 16V 100N P
C410	065G0603104 12	CER2 0603 X7R 16V 100N P
C411	065G0603104 12	CER2 0603 X7R 16V 100N P
C413	065G0603104 12	CER2 0603 X7R 16V 100N P
C414	065G0603104 12	CER2 0603 X7R 16V 100N P
C416	065G0603104 12	CER2 0603 X7R 16V 100N P
C417	065G0603104 12	CER2 0603 X7R 16V 100N P
C418	065G0603104 12	CER2 0603 X7R 16V 100N P
C430	065G0603220 31	CER1 0603 NP0 50V 22P PM
C428	065G0603220 31	CER1 0603 NP0 50V 22P PM
C427	065G0603220 31	CER1 0603 NP0 50V 22P PM
C412	065G0603224 17	CAP:CER 0.22UF-20%-80% 1
C429	065G0603339 31	CAP:CER 3.3+-0.5PF 50V SMT 060
C403	065G0603473 32	CHIP 0.047UF 50V X7R
C404	065G0603473 32	CHIP 0.047UF 50V X7R
C405	065G0603473 32	CHIP 0.047UF 50V X7R
C406	065G0603473 32	CHIP 0.047UF 50V X7R
C407	065G0603473 32	CHIP 0.047UF 50V X7R
C408	065G0603473 32	CHIP 0.047UF 50V X7R
FB407	071G 56D102	B201209D102TT
FB408	071G 56K121 M	CHIP BEAD
FB410	071G 56K121 M	CHIP BEAD
FB411	071G 56K121 M	CHIP BEAD
FB412	071G 56K121 M	CHIP BEAD
FB413	071G 56K121 M	CHIP BEAD
FB701	071G 56K121 M	CHIP BEAD
FB702	071G 56K121 M	CHIP BEAD
FB703	071G 56K121 M	CHIP BEAD
FB704	071G 56K121 M	CHIP BEAD
FB707	071G 56K121 M	CHIP BEAD
FB414	071G 59B121 K	CHIP BEAD 120 OHM 0603FBM-11-1
FB415	071G 59B121 K	CHIP BEAD 120 OHM 0603FBM-11-1
FB418	071G 59B121 K	CHIP BEAD 120 OHM 0603FBM-11-1
FB401	071G 59B300 K	BEAD 30
FB403	071G 59B300 K	BEAD 30
FB404	071G 59B300 K	BEAD 30
D415	093G 64 33	DIO SIG SM BAV99 (PHSE)R
D414	093G 64 33	DIO SIG SM BAV99 (PHSE)R
D413	093G 64 33	DIO SIG SM BAV99 (PHSE)R
D412	093G 64 33	DIO SIG SM BAV99 (PHSE)R
D411	093G 64 33	DIO SIG SM BAV99 (PHSE)R
D410	093G 64 33	DIO SIG SM BAV99 (PHSE)R
D409	093G 64 33	DIO SIG SM BAV99 (PHSE)R
D408	093G 64 33	DIO SIG SM BAV99 (PHSE)R
D407	093G 64 33	DIO SIG SM BAV99 (PHSE)R
D406	093G 64 33	DIO SIG SM BAV99 (PHSE)R
D405	093G 64 33	DIO SIG SM BAV99 (PHSE)R
D404	093G 64 33	DIO SIG SM BAV99 (PHSE)R
D416	093G 64 42 PP	BAV70 SOT-23
D417	093G 64 42 PP	BAV70 SOT-23
ZD401	093G 39P599 T	MM3Z5V6B

ZD402	093G 39P599 T	MM3Z5V6B
ZD403	093G 39P599 T	MM3Z5V6B
ZD404	093G 39P599 T	MM3Z5V6B
ZD405	093G 39P599 T	MM3Z5V6B
ZD406	093G 39P599 T	MM3Z5V6B
ZD407	093G 39P599 T	MM3Z5V6B
ZD408	093G 39P599 T	MM3Z5V6B
ZD409	093G 39P599 T	MM3Z5V6B
ZD410	093G 39P599 T	MM3Z5V6B
ZD411	093G 39P599 T	MM3Z5V6B
ZD412	093G 39P599 T	MM3Z5V6B
ZD413	093G 39P599 T	MM3Z5V6B
ZD414	093G 39P599 T	MM3Z5V6B
ZD401	093G 39S 34 T	UDZS5.6B
ZD402	093G 39S 34 T	UDZS5.6B
ZD403	093G 39S 34 T	UDZS5.6B
ZD404	093G 39S 34 T	UDZS5.6B
ZD405	093G 39S 34 T	UDZS5.6B
ZD406	093G 39S 34 T	UDZS5.6B
ZD407	093G 39S 34 T	UDZS5.6B
ZD408	093G 39S 34 T	UDZS5.6B
ZD409	093G 39S 34 T	UDZS5.6B
ZD410	093G 39S 34 T	UDZS5.6B
ZD411	093G 39S 34 T	UDZS5.6B
ZD412	093G 39S 34 T	UDZS5.6B
ZD413	093G 39S 34 T	UDZS5.6B
ZD414	093G 39S 34 T	UDZS5.6B
D702	093G2040 3F	FA20-04
D701	093G2040 3F	FA20-04
	715G1767 1	MAIN BOARD PCB
	KEPC6QA2P8	KEY BOARD
CN004	033G3802 2H	WAFER 2P RIGHT ANGLE
CN003	033G3802 2H	WAFER 2P RIGHT ANGLE
CN001	033G8027 12 H	PIN HEADER 2*6 R/A
	040G 581 26605	LABEL-P/N
SW001	077G 600 1 CJ	TACT SWITCH
SW002	077G 600 1 CJ	TACT SWITCH
SW003	077G 600 1 CJ	TACT SWITCH
SW004	077G 600 1 CJ	TACT SWITCH
SW005	077G 600 1 CJ	TACT SWITCH
DP101	081G 12 2 GP	GP36032ME/50-ZO
CN002	088G 30211K	PHONE JACK 5PIN
GND1	095G 900633	WIRE HARNESS
R101	061G0805102	CHIP 1KOHM 1/10W
R102	061G0805102	CHIP 1KOHM 1/10W
C101	065G0603271 31	CHIP 270PF 50V NPO
C102	065G0603271 31	CHIP 270PF 50V NPO
ZD109	093G 64 49 SU	DIODE ESD EGA 10603V05A1-B INPAQ
ZD101	093G 64 49 SU	DIODE ESD EGA 10603V05A1-B INPAQ
ZD102	093G 64 49 SU	DIODE ESD EGA 10603V05A1-B INPAQ
ZD103	093G 64 49 SU	DIODE ESD EGA 10603V05A1-B INPAQ

ZD104	093G 64 49 SU	DIODE ESD EGA 10603V05A1-B INPAQ
ZD105	093G 64 49 SU	DIODE ESD EGA 10603V05A1-B INPAQ
ZD106	093G 64 49 SU	DIODE ESD EGA 10603V05A1-B INPAQ
ZD107	093G 64 49 SU	DIODE ESD EGA 10603V05A1-B INPAQ
ZD108	093G 64 49 SU	DIODE ESD EGA 10603V05A1-B INPAQ
	715G2127 1	KEY BOARD PCB
	PWPC942MA1P	POWER BOARD
CN901	015G8033 1	BKT_AC INLET
CN804	033G8021 2D U	3.5MM WAFER
CN803	033G8021 2D U	3.5MM WAFER
CN802	033G8021 2D U	3.5MM WAFER
CN801	033G8021 2D U	3.5MM WAFER
CN804	033G8021 2E F	WAFER
CN803	033G8021 2E F	WAFER
CN802	033G8021 2E F	WAFER
CN801	033G8021 2E F	WAFER
	040G 45762420A	LABEL 25X6MM
IC902	056G 139 3A	PC123Y22FZOF
NR901	061G 58080 WT	8 OHM NCT
C816	065G 3J2206ET	22PF 5% SL 3KV TDK
C834	065G 3J2206ET	22PF 5% SL 3KV TDK
C837	065G 3J2206ET	22PF 5% SL 3KV TDK
C841	065G 3J2206ET	22PF 5% SL 3KV TDK
C825	065G 3J5096ET	5PF 5% SL 3KV
C826	065G 3J5096ET	5PF 5% SL 3KV
C835	065G 3J5096ET	5PF 5% SL 3KV
C824	065G 3J5096ET	5PF 5% SL 3KV
C901	065G306M1022BM	Y1.CAP.001UF 250VAC MURATA
C902	065G306M1022BM	Y1.CAP.001UF 250VAC MURATA
C900	065G306M2222BM	2200PF +-20% 250VAC
C937	067G215D471 4K	ED 470UF 25V
C936	067G215D471 4K	ED 470UF 25V
C935	067G215D471 4K	ED 470UF 25V
C912	067G215D471 4K	ED 470UF 25V
C911	067G215D471 4K	ED 470UF 25V
C904	067G215D471 4K	ED 470UF 25V
C811	067G215D471 4K	ED 470UF 25V
C815	067G215D471 4K	ED 470UF 25V
C811	067G215L471 4H	470UF 25V
C815	067G215L471 4H	470UF 25V
C904	067G215L471 4H	470UF 25V
C911	067G215L471 4H	470UF 25V
C912	067G215L471 4H	470UF 25V
C935	067G215L471 4H	470UF 25V
C936	067G215L471 4H	470UF 25V
C937	067G215L471 4H	470UF 25V
C905	067G215S10115H	100UF 450V 18*36 105 BY
C905	067G215S10115K	100UF 450V
C905	067G215Z10115K	ELCAP 100UF M 450V
C905	067G305T10115H	ELCAP 105°C 100UF M 450V
L902	073G 174 65 H	LINE FILTER

L902	073G 174 65 LS	LINE FILTER BY LISHIN
L904	073G 253 91 T	CHOKE
L903	073G 253 91 T	CHOKE
L903	073G 253 91 LS	CHOKE BY LI SHIN
L904	073G 253 91 LS	CHOKE BY LI SHIN
L901	073L 174 53 LG GP	CHOKE
L901	073L 174 53LSG GP	CHOKE BY LISHIN
T901	080GL17T 37 L GP	XFMR FOR POWER LITAI
T901	080GL17T 37 LS GP	XFMR FOR POWER LISHIN
PT802	080GL19T 8DN1	X'FMR DARFONTK.2006M.101
PT801	080GL19T 8DN1	X'FMR DARFONTK.2006M.101
F901	084G 55 7W	FUSE 3.15A 250V WICKMANN
BD901	093G 50460900	BRIDGE DIODE GBU408 LITEON
CN902	095G8014 12 65	HARNESS 12P-12P 100MM
	0M1G1730 6120 GP	M3*6 SCREW
	705GQ9K3 57001	Q903 ASS'Y
Q903	057G 667 21	STP10NK70ZFP
	AM1G1730 8120 GP	SCREW
	Q90G0035 1	HEAT SINK
	705GQ9K3 61001	R905 ASS'Y
R905	061G152M10458F	100K OHM 5% 2W
	096G 29 6	H.S. TUBE
	705GQ9K3 61002	R914 ASS'Y
R914	061G152M47858F	RST MOFR 0.47 OHM +-5% 2WS
	096G 29 6	H.S. TUBE
	705GQ9K3 87001	CN901 ASS'Y
	052G6025 12113	MYLAR
CN901	087G 501 27 RF GP	AC SOCKET
	705GQ9K3 93001	D908 ASS'Y
D908	093G 60252	SP20150
D908	093G 60281	DIODE SP20150R ITO-220 SECOS
	AM1G1730 8120 GP	SCREW
	Q90G0009 1	HEAT SINK
	705GQ9K3 93004	D909 ASS'Y
	090G6241 2 GP	HEAT SINK
D909	093G 60252	SP20150
D909	093G 60281	DIODE SP20150R ITO-220 SECOS
	AM1G1730 8120 GP	SCREW
IC901	056G 379 61	LD7575PS SOP-8
IC801	056G 608 10	0Z9938
Q801	057G 417 4	PMBS3904/PHILIPS-SMT(04)
Q802	057G 417 4	PMBS3904/PHILIPS-SMT(04)
Q803	057G 417 4	PMBS3904/PHILIPS-SMT(04)
Q804	057G 759 2	RK7002
Q807	057G 759 2	RK7002
Q808	057G 759 2	RK7002
Q809	057G 759 2	RK7002
Q810	057G 759 2	RK7002
Q805	057G 763 6	AO4828L
Q806	057G 763 6	AO4828L
Q805	057G 763 14	AM9945N

Q806	057G 763 14	AM9945N
JR801	061G0805000	0 OHM 1/10W
JR804	061G0805000	0 OHM 1/10W
JR805	061G0805000	0 OHM 1/10W
JR807	061G0805000	0 OHM 1/10W
R922	061G0805102	CHIP 1KOHM 1/10W
R921	061G0805102	CHIP 1KOHM 1/10W
R920	061G0805102	CHIP 1KOHM 1/10W
R843	061G0805102	CHIP 1KOHM 1/10W
R836	061G0805102	CHIP 1KOHM 1/10W
R912	061G0805103	10 KOHM 1/10W
R812	061G0805103	10 KOHM 1/10W
R806	061G0805103	10 KOHM 1/10W
R804	061G0805103	10 KOHM 1/10W
R803	061G0805103	10 KOHM 1/10W
R913	061G0805104	RST CHIP 100K 1/8W 5%
R815	061G0805104	RST CHIP 100K 1/8W 5%
R801	061G0805104	RST CHIP 100K 1/8W 5%
R810	061G0805105	1MOHM 1/10W
R813	061G0805105	1MOHM 1/10W
R816	061G0805105	1MOHM 1/10W
R846	061G0805105	1MOHM 1/10W
R847	061G0805105	1MOHM 1/10W
R848	061G0805105	1MOHM 1/10W
R849	061G0805105	1MOHM 1/10W
R860	061G0805105	1MOHM 1/10W
C808	061G0805184	RST CHIPR 180 KOHM +-5% 1/8W
R926	061G0805202	RST CHIP 2K 1/8W 5%
R924	061G0805240 1F	2.4KOHM 1/10W 1%
R802	061G0805304	RST CHIPR 300 KOHM +-5% 1/8W
R923	061G0805330 2F	33 KOHM 1/10W 1%
R925	061G0805360 1F	3.6KOHM 1/10W 1%
R817	061G0805393	RST CHIPR 39KOHM +-5% 1/8W
R850	061G0805472	RST CHIPR 4.7 KOHM +-5% 1/8W
R852	061G0805472	RST CHIPR 4.7 KOHM +-5% 1/8W
R853	061G0805472	RST CHIPR 4.7 KOHM +-5% 1/8W
R808	061G0805473	RST CHIPR 47 KOHM +-5% 1/8W
R826	061G0805510 0F	RST CHIPR 510 OHM +-1% 1/8W
R825	061G0805513	RST CHIPR 51 KOHM +-5% 1/8W
R841	061G0805560 0F	RST CHIPR 560 OHM +-1% 1/8W
R824	061G0805751	RST CHIPR 750 OHM +-5% 1/8W
R858	061G0805751	RST CHIPR 750 OHM +-5% 1/8W
R827	061G0805752	RST CHIPR 7.5 KOHM +-5% 1/8W
R831	061G0805752	RST CHIPR 7.5 KOHM +-5% 1/8W
R814	061G0805754	RST CHIPR 750 KOHM +-5% 1/8W
R830	061G0805823	RST CHIPR 82 KOHM +-5% 1/8W
R823	061G0805823	RST CHIPR 82 KOHM +-5% 1/8W
R928	061G1206000	0 OHM 1/8W
R932	061G1206000	0 OHM 1/8W
JR902	061G1206000	0 OHM 1/8W
JR901	061G1206000	0 OHM 1/8W

JR809	061G1206000	0 OHM 1/8W
JR806	061G1206000	0 OHM 1/8W
JR803	061G1206000	0 OHM 1/8W
R937	061G1206101	100 1206
R936	061G1206101	100 1206
R935	061G1206101	100 1206
R934	061G1206101	100 1206
R916	061G1206101	100 1206
R906	061G1206101	100 1206
R911	061G1206102	RST CHIPR 1 KOHM +-5% 1/4W
R927	061G1206103	10 KOHM 1/8W
R828	061G1206150	15 OHM 1/8W
R829	061G1206150	15 OHM 1/8W
R818	061G1206150	15 OHM 1/8W
R819	061G1206150	15 OHM 1/8W
R910	061G1206220	RST CHIPR 22 OHM +-5% 1/4W
R807	061G1206220	RST CHIPR 22 OHM +-5% 1/4W
R909	061G1206339	3.3 1206
R931	061G1206392	RST CHIPR 3.9KOHM +-5% 1/4W
R938	061G1206392	RST CHIPR 3.9KOHM +-5% 1/4W
R904	061G1206392	RST CHIPR 3.9KOHM +-5% 1/4W
R805	061G1206471	470 1206
R919	061G1206471	470 1206
R851	061G1206472	RST CHIPR 4.7 KOHM +-5% 1/4W
R842	061G1206519	RST CHIPR 5.1 OHM +-5% 1/4W
R837	061G1206519	RST CHIPR 5.1 OHM +-5% 1/4W
R901	061G1206684	RST CHIPR 680 KOHM +-5% 1/4W
R902	061G1206684	RST CHIPR 680 KOHM +-5% 1/4W
R903	061G1206684	RST CHIPR 680 KOHM +-5% 1/4W
C805	065G0805102 31	1000PF 50V NPO
C807	065G0805103 32	10NF/50V/0805/X7R
C842	065G0805104 32	CHIP 0.1U 50V X7R
C839	065G0805104 32	CHIP 0.1U 50V X7R
C838	065G0805104 32	CHIP 0.1U 50V X7R
C829	065G0805104 32	CHIP 0.1U 50V X7R
C828	065G0805104 32	CHIP 0.1U 50V X7R
C801	065G0805104 32	CHIP 0.1U 50V X7R
C843	065G0805104 32	CHIP 0.1U 50V X7R
C844	065G0805104 32	CHIP 0.1U 50V X7R
C916	065G0805104 32	CHIP 0.1U 50V X7R
C917	065G0805104 32	CHIP 0.1U 50V X7R
C918	065G0805104 32	CHIP 0.1U 50V X7R
C919	065G0805104 32	CHIP 0.1U 50V X7R
C804	065G0805105 22	CHIP 1UF 25V X7R 0805
C806	065G0805105 22	CHIP 1UF 25V X7R 0805
C840	065G0805105 22	CHIP 1UF 25V X7R 0805
C909	065G0805221 31	220PF 50V NPO
C809	065G0805223 32	CHIP 0.022UF 50V X7R 0805
C814	065G0805224 22	CAIP CAP 0.22 UF 25V X7R
C818	065G0805332 32	3200PF/25V/X7R
C827	065G0805332 32	3200PF/25V/X7R

C810	065G0805471 31	CHIP 470PF 50V NPO
C820	065G0805471 31	CHIP 470PF 50V NPO
C831	065G0805471 31	CHIP 470PF 50V NPO
C910	065G0805471 31	CHIP 470PF 50V NPO
C819	065G0805473 32	CHIP 0.047UF 50V X7R
C848	065G1206102 32	CHIP 1000PF/XTR +-5%
C847	065G1206102 32	CHIP 1000PF/XTR +-5%
C846	065G1206102 32	CHIP 1000PF/XTR +-5%
C845	065G1206102 32	CHIP 1000PF/XTR +-5%
C823	065G1206102 72	CHIP 1000PF 500V X7R
C822	065G1206102 72	CHIP 1000PF 500V X7R
C813	065G1206102 72	CHIP 1000PF 500V X7R
C812	065G1206102 72	CHIP 1000PF 500V X7R
C908	065G1206104 32	CHIP 0.1UF 25V X7R 1206
D806	093G 64 33	DIO SIG SM BAV99 (PHSE)R
D805	093G 64 33	DIO SIG SM BAV99 (PHSE)R
D804	093G 64 33	DIO SIG SM BAV99 (PHSE)R
D803	093G 64 33	DIO SIG SM BAV99 (PHSE)R
D802	093G 64 33	DIO SIG SM BAV99 (PHSE)R
D801	093G 64 33	DIO SIG SM BAV99 (PHSE)R
D904	093G 6432V	LL4148-GSO8
D903	093G 6432V	LL4148-GSO8
ZD905	093G 39S 12 T	RLZ20B LLDS
ZD801	093G 39S 24 T	RLZ 5.6B LLDS
ZD902	093G 39S 24 T	RLZ 5.6B LLDS
ZD903	093G 39S 38 T	PTZ 9.1B
ZD901	093G 39S 40 T	RLZ 13B LLDS
ZD904	093G 39S 44 T	RLZ18B LLDS
D809	093G 64S511SEM	IN4148W
D810	093G 64S511SEM	IN4148W
D811	093G 64S511SEM	IN4148W
D812	093G 64S511SEM	IN4148W
D813	093G 64S511SEM	IN4148W
CN901	006G 31500	EYELET
C905	006G 31502	1.5MM RIVET
F901	006G 31502	1.5MM RIVET
L901	006G 31502	1.5MM RIVET
L902	006G 31502	1.5MM RIVET
NR901	006G 31502	1.5MM RIVET
PT801	006G 31502	1.5MM RIVET
PT802	006G 31502	1.5MM RIVET
Q903	006G 31502	1.5MM RIVET
T901	006G 31502	1.5MM RIVET
IC903	056G 158 12	KIA431A-AT/P TO-92
R822	061G212Y625 KT	MGFR 6.2MOHM +-5% 1/2W
R832	061G212Y625 KT	MGFR 6.2MOHM +-5% 1/2W
C930	065G 2K152 1T GP	CERAMIC CAP
C933	065G 2K152 1T GP	CERAMIC CAP
C934	065G 2K152 1T GP	CERAMIC CAP
C906	067G 2151007NT	KY50VB10M-TP5 5*11.5
C907	067G 2151007NT	KY50VB10M-TP5 5*11.5

FB901	071G 55 29 GP	FERRITE BEAD
D901	093G 6026T52T	RECTIFIER DIODE FR107
D902	093G 6038T52T	FR103
	715G1899 1 HP	POWER BOARD PCB
L902	S73G17465V	TRANSFORMER ASS'Y
	034FPF20P01	BOBBIN
PT802	S80GL19T8V1	TRANSFORMER ASS'Y
	S80GL19T8V1Z	TRANSFORMER ASS'Y
	034FPE19P03	CASE EEL19
PT801	S80GL19T8V1	TRANSFORMER ASS'Y
	S80GL19T8V1Z	TRANSFORMER ASS'Y
	034FPE19P03	CASE EEL19
	Q40G 19N61526A	RATING LABEL
	Q41G900261518B	MANUAL
	Q44G9030 1	EPS(L)
	Q44G9030 2	EPS(R)
	Q44G9030624 1A	CARTON
	Q45G 88606 14	PE BAG FOR STAND
	Q45G 88606 16	PE BAG FOR CLAMP
	Q45G 88607 22	PE BAG FOR BASE
	Q45G 88607 23	PE BAG FOR MONITOR
	Q52G6025 13 40	MYLAR
M01	S15G00323	FP ASS'Y
	002F6365093 M4	RIVET
	002F6570100 M4	RIVET
	002F6365276 M3	RIVET
	002F6370276 M4	RIVET
	002F6365284 M3	RIVET
	002F6355204 M3	RIVET
	002F6370072 M4	RIVET
	002F6370148 M4	RIVET
	015F 008200	SGCC
	015F 008200 B1	SGCC
	015F 008200 A1	SGCC
	015F 008200 D1	SGCC