

acer

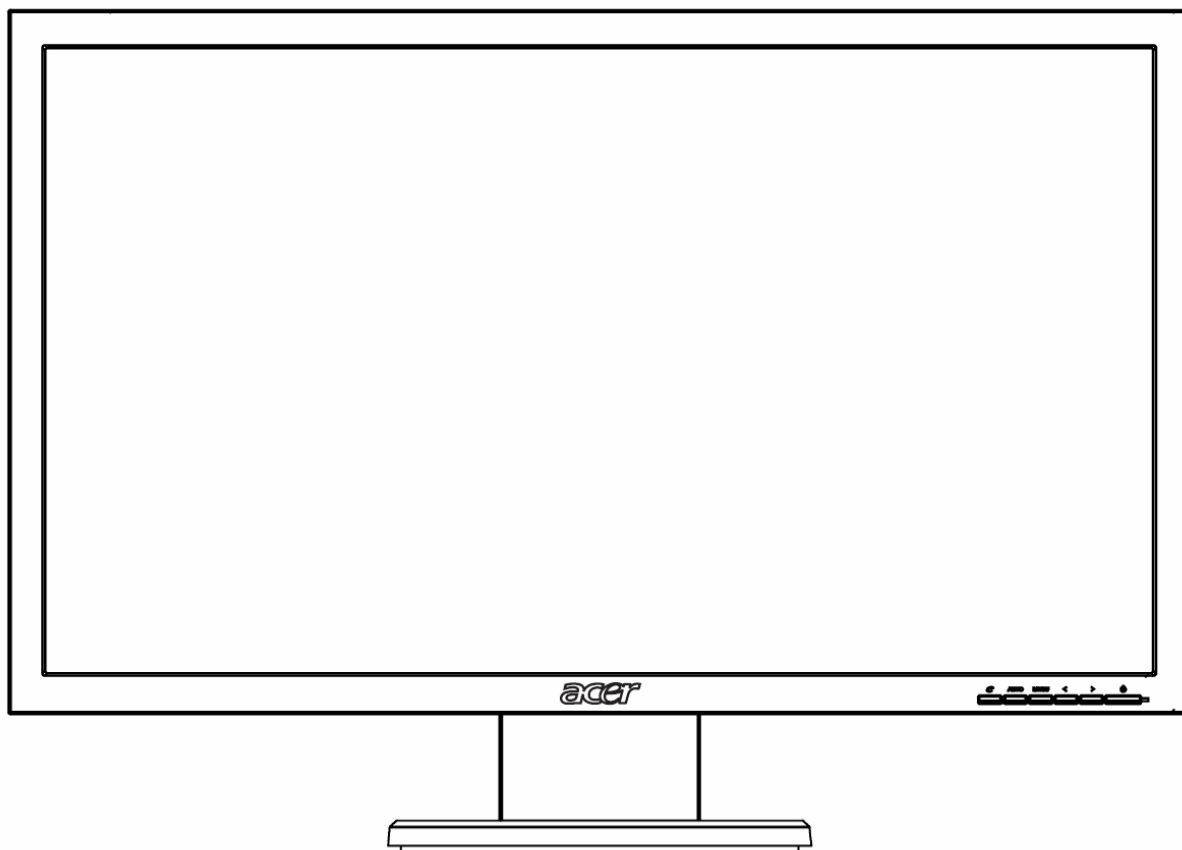

Acer V233H
Service Guide

Copyright

Copyright © 2003 by Acer Incorporated. All rights reserved. No part of this publication may be reproduced, Transmitted, transcribed, stored in a retrieval system, or translated into any language or computer language, in any form or by any means, electronic, mechanical, magnetic, optical, chemical, manual or otherwise, without the prior written permission of Acer Incorporated.

Disclaimer

The information in this guide is subject to change without notice. Acer Incorporated makes no representations or warranties, either expressed or implied, with respect to the contents hereof and specifically disclaims any warranties of merchantability or fitness for any particular purpose. Any Acer Incorporated software described in this manual is sold or licensed "as is". Should the programs prove defective following their purchase, the buyer (and not Acer Incorporated, its distributor, or its dealer) assumes the entire cost of all necessary servicing, repair, and any incidental or consequential damages resulting from any defect in the software.

Intel is a registered trademark of Intel Corporation.

Pentium and Pentium II/III are trademarks of Intel Corporation.

Other brand and product names are trademarks and/or registered trademarks of their respective holders.

Trademarks

Acer is a registered trademark of Acer Incorporated.

All other trademarks are property of their respective owners.

Conventions

The following conventions are used in this manual:

Screen messages	Denotes actual messages that appear on screen.
Note	Gives bits and pieces of additional information related to the current topic.
Warning	Alerts you to any damage that might result from doing or not doing specific actions.
Caution	Gives precautionary measures to avoid possible hardware or software problems.
Important	Remind you to do specific actions relevant to the accomplishment of procedures.

Preface

Before using this information and the product it supports, please read the following general information.

1. This Service Guide provides you with all technical information relating to the BASIC CONFIGURATION decided for Acer's "global" product offering. To better fit local market requirements and enhance product competitiveness, your regional office may have decided to extend the functionality of a machine (e.g. add-on card, modem, or extra memory capability). These LOCALIZED FEATURES will NOT be covered in this generic service guide. In such cases, please contact your regional offices or the responsible personnel/channel to provide you with further technical details.
2. Please note WHEN ORDERING FRU PARTS, that you should check the most up-to-date information available on your regional web or channel. If, for whatever reason, a part number change is made, it will not be noted in the printed Service Guide. For ACER-AUTHORIZED SERVICE PROVIDERS, your Acer office may have a DIFFERENT part number code to those given in the FRU list of this printed Service Guide. You MUST use the list provided by your regional Acer office to order FRU parts for repair and service of customer machines.

Warning: (For FCC Certified Models)

Note: This equipment has been tested and found to comply with the limits for a Class B digital device, pursuant to Part 15 of the FCC Rules. These limits are designed to provide reasonable protection against harmful interference in a residential installation. This equipment generates, uses and can radiate radio frequency energy, and if not installed and used in accordance with the instructions, may cause harmful interference to radio communications. However, there is no guarantee that interference will not occur in a particular installation. If this equipment does cause harmful interference to radio or television reception, which can be determined by turning the equipment off and on, the user is encouraged to try to correct the interference by one or more of the following measures:

1. Reorient or relocate the receiving antenna.
2. Increase the separation between the equipment and receiver.
3. Connect the equipment into an outlet on a circuit different from that to which the receiver is connected.
4. Consult the dealer or an experienced radio/TV technician for help.

Notice:

1. The changes or modifications not expressly approved by the party responsible for compliance could void the user's authority to operate the equipment.
2. Shielded interface cables and AC power cord, if any, must be used in order to comply with the emission limits.
3. The manufacturer is not responsible for any radio or TV interference caused by unauthorized modification to this equipment. It is the responsibility of the user to correct such interference.

As ENERGY STAR[®] Partner our company has determined that this product meets the ENERGY STAR[®] guidelines for energy efficiency.

Warning:

To prevent fire or shock hazard, do not expose the monitor to rain or moisture. Dangerous high voltages are present inside the monitor. Do not open the cabinet. Refer servicing to qualified personnel only.

Precautions

- Do not use the monitor near water, e.g. near a bathtub, washbowl, kitchen sink, laundry tub, swimming pool or in a wet basement.
- Do not place the monitor on an unstable trolley, stand, or table. If the monitor falls, it can injure a person and cause serious damage to the appliance. Use only a trolley or stand recommended by the manufacturer or sold with the monitor. If you mount the monitor on a wall or shelf, use a mounting kit approved by the manufacturer and follow the kit instructions.
- Slots and openings in the back and bottom of the cabinet are provided for ventilation. To ensure reliable operation of the monitor and to protect it from overheating, be sure these openings are not blocked or covered. Do not place the monitor on a bed, sofa, rug, or similar surface. Do not place the monitor near or over a radiator or heat register. Do not place the monitor in a bookcase or cabinet unless proper ventilation is provided.
- The monitor should be operated only from the type of power source indicated on the label. If you are not sure of the type of power supplied to your home, consult your dealer or local power company.
- The monitor is equipped with a three-pronged grounded plug, a plug with a third (grounding) pin. This plug will fit only into a grounded power outlet as a safety feature. If your outlet does not accommodate the three-wire plug, have an electrician install the correct outlet, or use an adapter to ground the appliance safely. Do not defeat the safety purpose of the grounded plug.
- Unplug the unit during a lightning storm or when it will not be used for long periods of time. This will protect the monitor from damage due to power surges.
- Do not overload power strips and extension cords. Overloading can result in fire or electric shock.
- Never push any object into the slot on the monitor cabinet. It could short circuit parts causing a fire or electric shock. Never spill liquids on the monitor.
- Do not attempt to service the monitor yourself; opening or removing covers can expose you to dangerous voltages and other hazards. Please refer all servicing to qualified service personnel
- To ensure satisfactory operation, use the monitor only with UL listed computers which have appropriate configured receptacles marked between 100 - 240V AC, Min. 5A.
- The wall socket shall be installed near the equipment and shall be easily accessible.

Special Notes on LCD Monitors

The following symptoms are normal with LCD monitor and do not indicate a problem.

Notes

- Due to the nature of the fluorescent light, the screen may flicker during initial use. Turn off the Power Switch and then turn it on again to make sure the flicker disappears.
- You may find slightly uneven brightness on the screen depending on the desktop pattern you use.
- The LCD screen has effective pixels of 99.99% or more. It may include blemishes of 0.01% or less such as a missing pixel or a pixel lit all of the time.
- Due to the nature of the LCD screen, an afterimage of the previous screen may remain after switching the image, when the same image is displayed for hours. In this case, the screen is recovered slowly by changing the image or turning off the Power Switch for hours.

Table Of Contents

Chapter 1	Monitor Features	7
	Introduction	7
	Electrical Requirements	8
	LCD Monitor General Specification	9
	LCD Panel Specification	10
	Factory Preset Timing	12
	Monitor Block Diagram	13
	Main Board Diagram	14
	Power Board Diagram	15
	Software Flow chart	16
	Main Board Layout	18
	Installation	19
Chapter 2	Operating Instructions	21
	User Controls	21
	Front Panel Controls	21
	eColor Management (OSD)	22
	How to Adjust a Setting	23
	How To Optimize The DOS-Mode	27
	Enter into the factory mode	27
Chapter 3	Machine Disassembly	28
Chapter 4	Troubleshooting	32
Chapter 5	Connector Information	38
Chapter 6	FRU (Field Replacement Unit) List	39
	Exploded Diagram	39
Chapter 7	Schematic Diagram	43

Introduction**Scope**

This short specification describes the electrical, optical and functional performance requirements for a 63.2cm (23.6") TFT LCD color monitor with VGA&DVI compatible interface.

Description

The LCD monitor is designed with the latest LCD technology to provide a performance oriented product with no radiation. This will alleviate the growing health concerns. It is also a space saving design, allowing more desktop space, and comparing to the traditional CRT monitor, it consumes less power and gets less weight in addition MTBF target is 50k hours or more.

Chart of V233H

Panel	LM230WF1-TLA3 GZ LGD
Signal Interface	D-Sub 15pin;DVI 24pin
Sync Type	Separate / Compatible
Color Temp User Adjust	Support
DDC	DDC2B
Speaker	Yes
Headphone Jack	Yes
Microphone Jack	No
USB Hub	No
Tilt / Swivel	Yes /No

Electrical Requirements of V233H

Standard Test Conditions

All tests shall be performed under the following conditions, unless otherwise specified.

Warm up time	> 30 min.
AC supply voltage	230V± 5%, 50± 3 Hz
Ambient temperature	20°C ± 5°C
Humidity	65% ± 20%
Display mode	1920 x 1080, 60 Hz, Pixel Clock: 148.5MHZ,all white
e-color mode	Set to "User" mode
Contrast control	Set to The value under user mode, which allows that the brightest two of 32 linear distributed gray-scales (0 ~ 700mv) can be distinguished.
Color temperature	6500°K
Brightness control	The value under user mode
Analog Input signal	700 mVss
Picture position and size	Factory preset value,
Viewing angle	90 ° H and V
Viewing distance	40 cm for LCD performance, 20 cm for LCD failures
Ambient illumination	Dark room < 1 cd/m2

Measurement systems

The units of measure stated in this document are listed below:

1 gamma = 1 nano tesla

1 tesla = 10,000 gauss

cm = in x 2.54

Lb = kg x 2.2

Degrees F = [°C x 1.8] + 32

Degrees C = [°F - 32]/1.8

$u' = 4x/(-2x + 12y + 3)$

$v' = 9y/(-2x + 12y + 3)$

$x = (27u'/4)/[(9u'/2) - 12v' + 9]$

$y = (3v')/[(9u'/2) - 12v' + 9]$

nits = cd/(m2) = Ft-L x 3.426

lux = foot-candle x 10.76

LCD Monitor General Specification

Model name	V233H	
LCD Panel	Driving system	TFT Color LCD
	Pixel pitch	0.265(H) x 0.265(V)
	Contrast Ratio	1000 : 1 (typ)
	Response time	5ms(Typ.). 8ms(max)
	Luminance of White	300 cd/m ² (Typ.)
Input	Separate Sync.	H/V TTL
	H-Frequency	30kHz – 83kHz
	V-Frequency	56-75Hz
Viewing angle	(H)88 (V) 85(Type)(CR>5)	
Display Colors	16.7M	
Display mode	1920 x 1080 @60Hz	
EPA ENERGY STAR®	ON Mode	< 65W
	OFF Mode	< 1W
Contrast control	Set to The value under user mode, which allows that the brightest two of 32 linear distributed gray-scales (0~ 700mv) can be distinguished.	
Power Source	100 V ~ 240 V, 50 ± 3Hz, 60 ± 3Hz	
Environmental Considerations	Operating Temp: 0° to 40°C Storage Temp: -20° to 60°C Operating Humidity: 15% to 90% Storage Humidity: 15% to 90% Operating Altitude: 12,000 feet Storage Altitude: 40,000 feet	
Peak surge current	< 55A peak at 240 VAC and cold starting	
Power line surge	No advance effects (no loss of information or defect)	

LCD Panel Specification of V233H

LM230WF1-TLA3 is a Color Active Matrix Liquid Crystal Display with an integral Cold Cathode Fluorescent Lamp(CCFL) backlight system. The matrix employs a-Si Thin Film Transistor as the active element. It is a transmissive type display operating in the normally white mode. It has a 23 inch diagonally measured active display area with FHD resolution (1080 vertical by 1920 horizontal pixel array) Each pixel is divided into Red,Green and Blue sub-pixels or dots which are arranged in vertical stripes. Gray scale or the brightness of the sub-pixel color is determined with a 8-bit gray scale signal for each dot, thus, presenting a palette of more than 16,7M colors with Advanced-FRC(Frame Rate Control).

General Specifications

Active screen size	23 inches(58.42cm) diagonal(Aspect ratio 16:9)
Outline Dimension	533.2(H) x 312.0(V) x 16.5(D) mm(Typ.)
Pixel Pitch	0.265 mm x 0.265 mm
Pixel Format	1920 horiz. By 1080 vert. Pixels RGB stripes arrangement
Interface	LVDS 2Port
Color depth	16.7M colors
Luminance, white	300 cd/m ² (Center 1Point, typ)
Viewing Angle (CR>10)	R/L 170(Typ.), U/D 160(Typ.)
Power Consumption	Total 30W (Typ.), (4.5W@V _{LCD} , 25.5W@I _{BL} =7.5mA)
Weight	2600g(typ.)
Display operating mode	Transmissive mode, normally White
Surface treatments	Hard coating(3H) & Anti-Glare treatment of the front polarizer

Block Diagram

TFT LCD Module

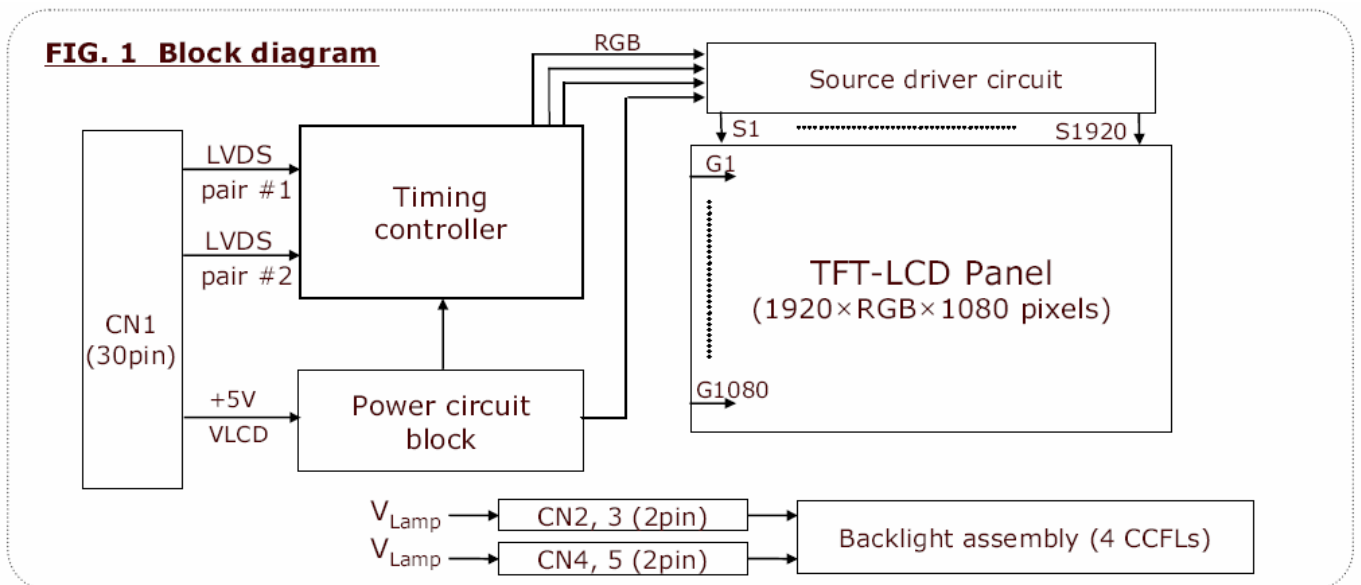

Electrical Characteristics

Parameter	Symbol	Values			Unit	Notes
		Min	Typ	Max		
MODULE :						
Power Supply Input Voltage	V_{LCD}	4.5	5.0	5.5	Vdc	
Permissive Power Input Ripple	V_{LCD}	-	-	0.4	V	3
Power Supply Input Current	$I_{LCD-MOSAIC}$	-	900	1100	mA	1
	$I_{LCD-BLACK}$	-	1050	1250	mA	2
Power Consumption	P_{LCD}	-	4.5	5.5	Watt	1
Inrush current	I_{RUSH}	-	-	3.0	A	4

Optical Specifications

Parameter	Symbol	Values			Units	Notes	
		Min	Typ	Max			
Contrast Ratio	CR	700	1000	-		1	
Surface Luminance, white	L_{WH}	250	300	-	cd/m ²	2	
Luminance Variation	δ_{WHITE} 9P	75			%	3	
Response Time	Rise Time	Tr_R	-	1.3	2.6	ms	4
	Decay Time	Tr_D	-	3.7	7.4	ms	4
Color Coordinates [CIE1931]	RED	R_x	Typ -0.03	0.644	Typ +0.03		
		R_y		0.336			
	GREEN	G_x		0.301			
		G_y		0.611			
	BLUE	B_x		0.146			
		B_y		0.070			
	WHITE	W_x		0.313			
		W_y		0.329			
Viewing Angle (CR>5)							
	x axis, right($\phi=0^\circ$)	θ_r	75	88		Degree	5
	x axis, left ($\phi=180^\circ$)	θ_l	75	88			
	y axis, up ($\phi=90^\circ$)	θ_u	70	85			
	y axis, down ($\phi=270^\circ$)	θ_d	70	85			
Viewing Angle (CR>10)							
	x axis, right($\phi=0^\circ$)	θ_r	70	85		Degree	5
	x axis, left ($\phi=180^\circ$)	θ_l	70	85			
	y axis, up ($\phi=90^\circ$)	θ_u	60	75			
	y axis, down ($\phi=270^\circ$)	θ_d	70	85			
Crosstalk				1.5	%	7	

Factory Preset Timing of V233H

Mode		Resolution		
1	Dos	720 x 400	70	Hz
2	VGA	640 x 480	60	Hz
3	VGA	640 x 480	67	Hz
4	SVGA	800 x 600	56	Hz
5	SVGA	800 x 600	60	Hz
6	XGA	1024 x 768	60	Hz
7	XGA	1024 x 768	70	Hz
8	SXGA	1280 x 1024	60	Hz
9	NA	1440 x 900	60	Hz
10	NA	1152x 864	75	Hz
11	UXGA	1920 x 1080	60	Hz
12	ACER	1280x 800	60	Hz

Monitor Block Diagram

The LCD MONITOR will contain a main board, a power board, and a key board which house the flat panel control logic, brightness control logic and DDC.

The power board will provide AC to DC Inverter voltage to drive the backlight of panel and the main board chips each voltage.

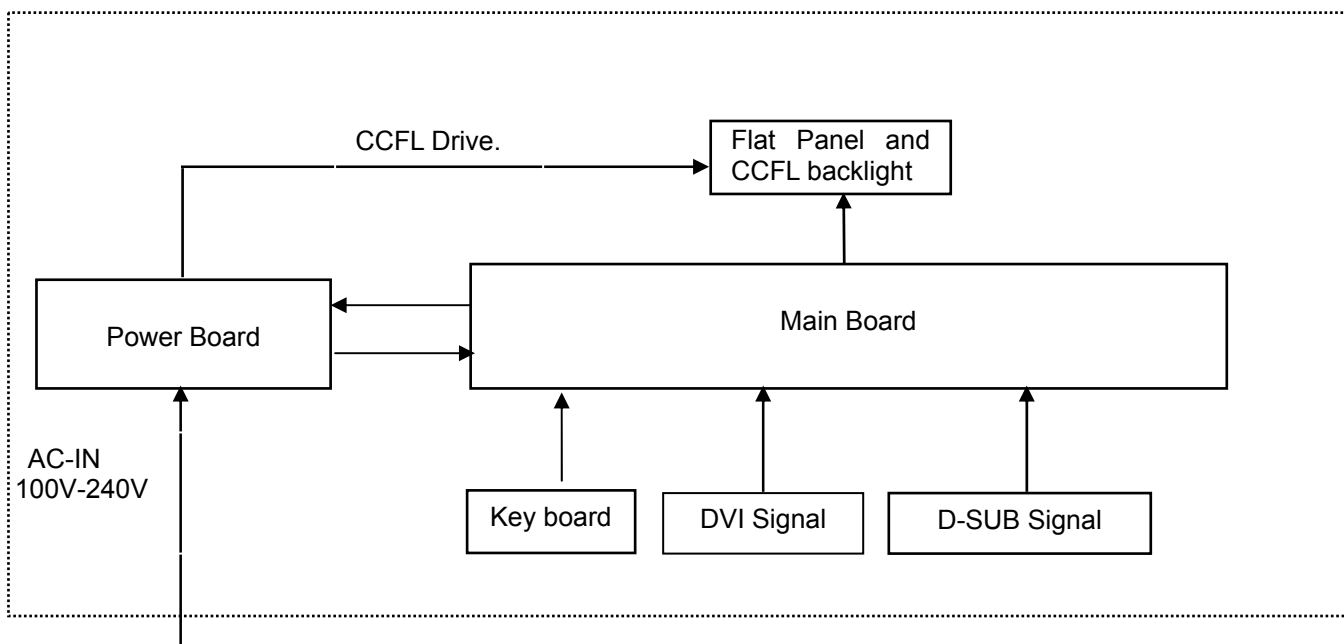

Main Board Diagram

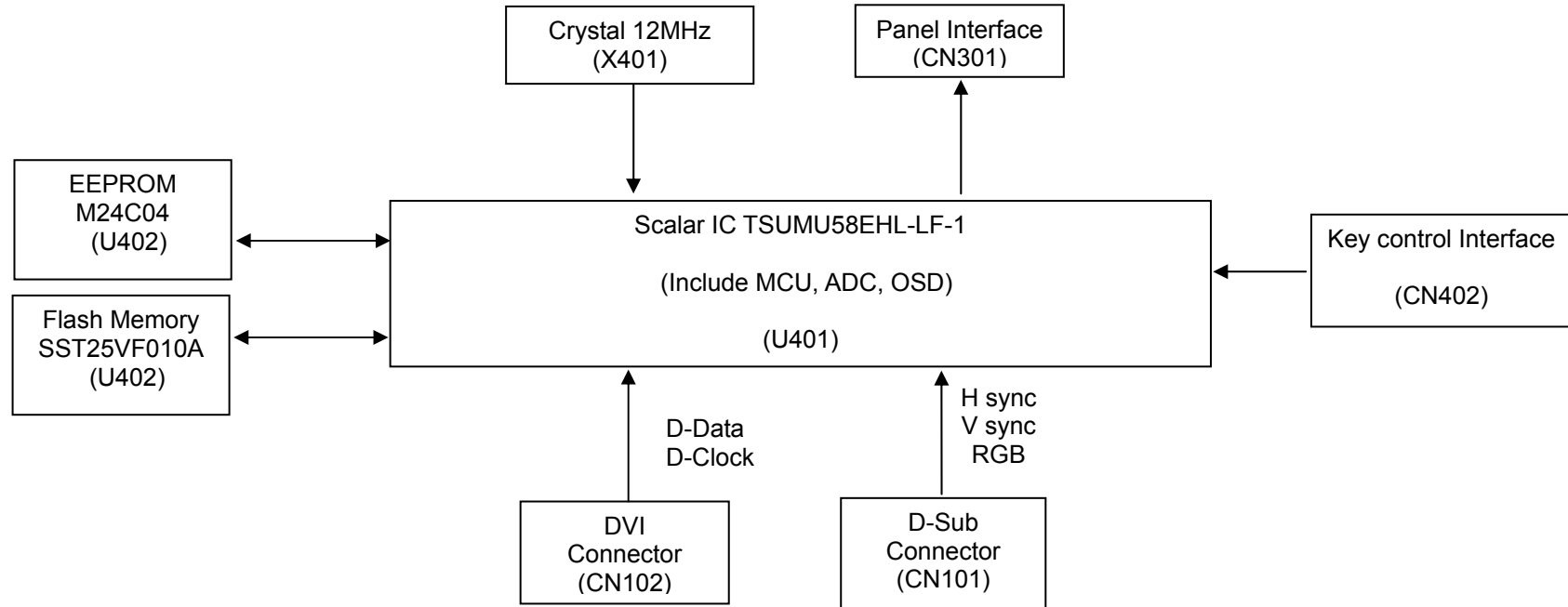

Power Board Diagram

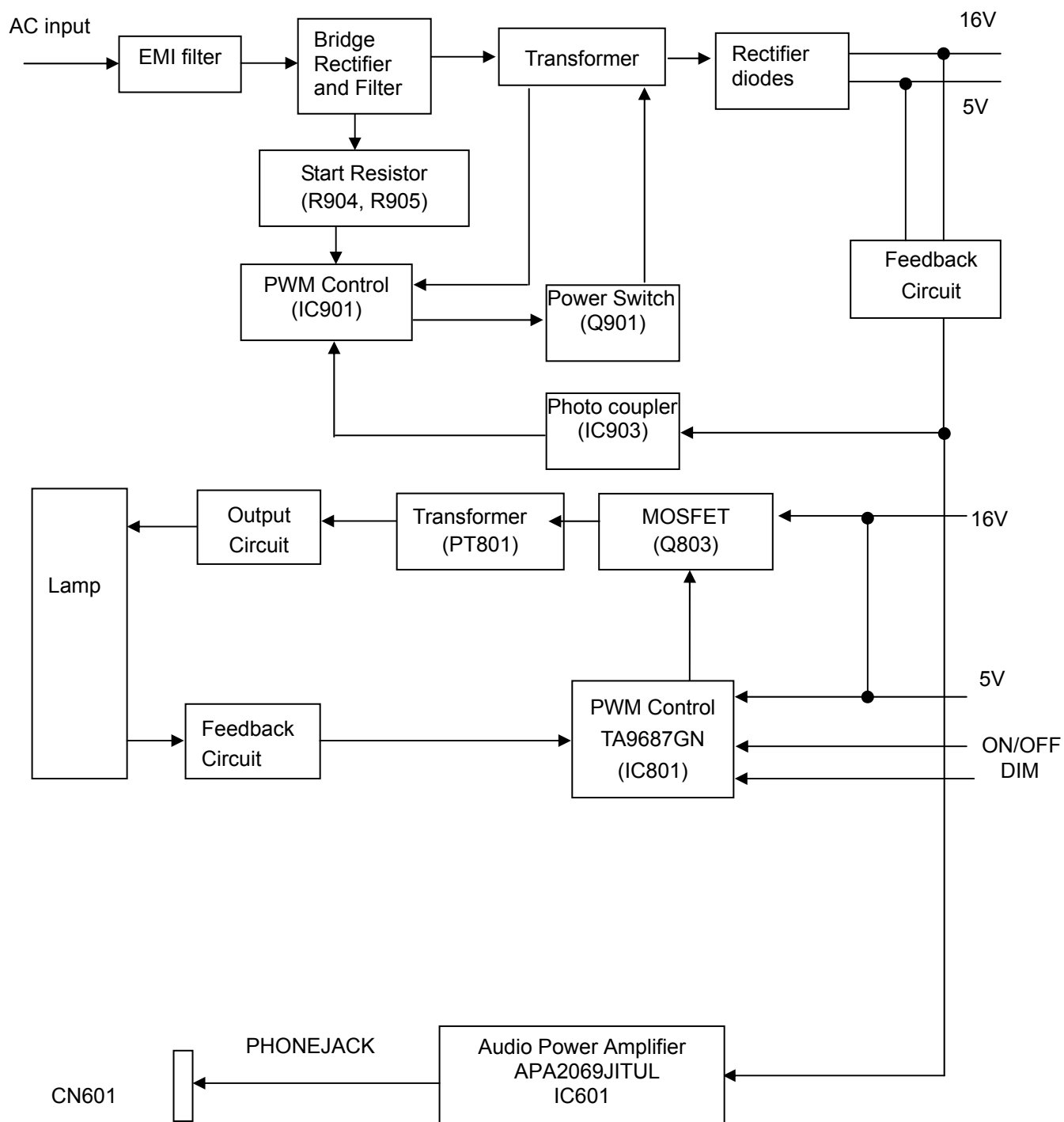

Software Flow Chart

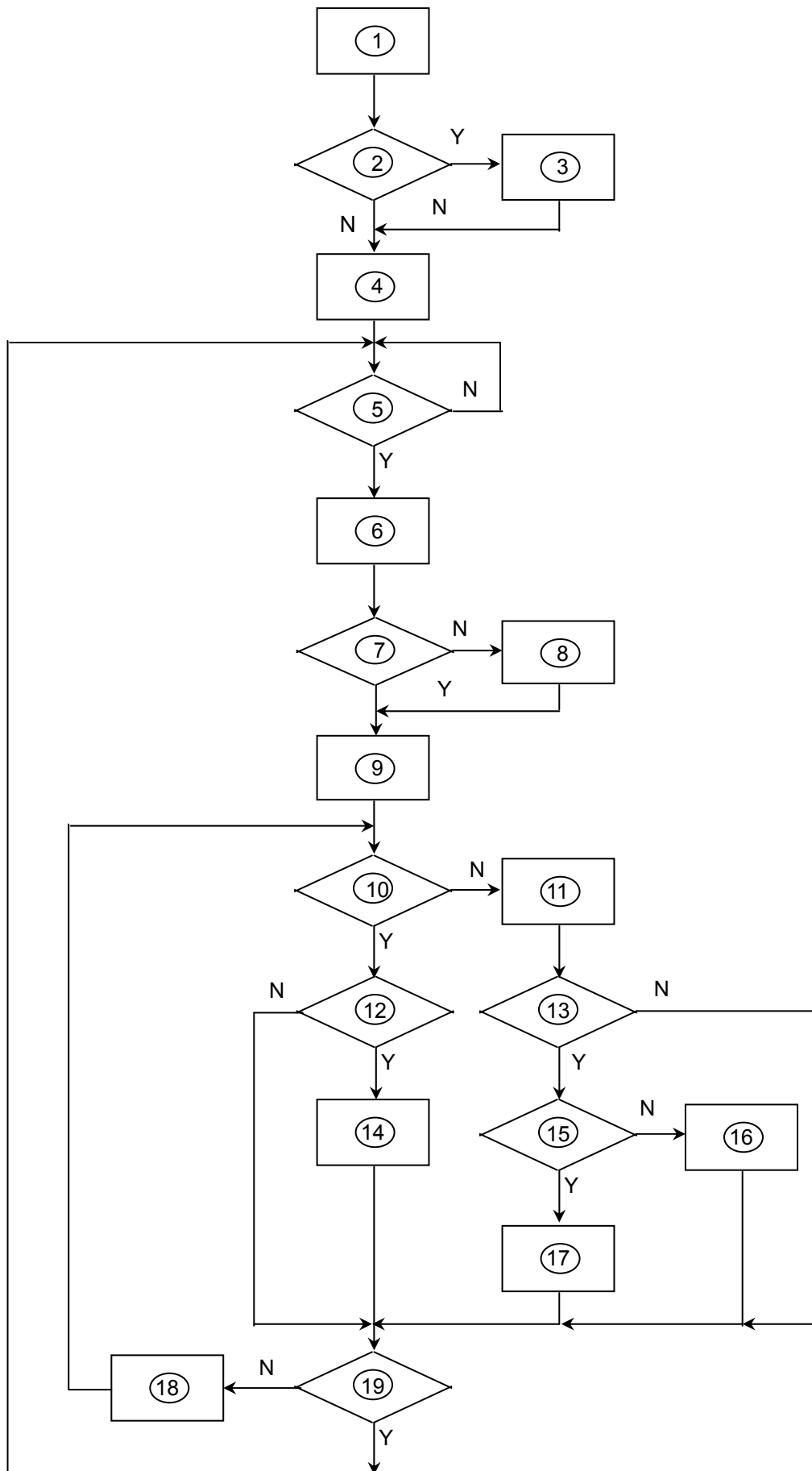

Remark:

1) MCU initializes.
2) Is the EEPROM blank?
3) Program the EEPROM by default values.
4) Get the PWM value of brightness from EEPROM.
5) Is the power key pressed?
6) Clear all global flags.
7) Are the AUTO and SELECT keys pressed?
8) Enter factory mode.
9) Save the power key status into EEPROM. Turn on the LED and set it to green color. Scalar initializes.
10) In standby mode?
11) Update the lifetime of back light.
12) Check the analog port, are there any signals coming?
13) Does the scalar send out an interrupt request?
14) Wake up the scalar.
15) Are there any signals coming from analog port?
16) Display "No connection Check Signal Cable" message. And go into standby mode after the message disappears.
17) Program the scalar to be able to show the coming mode.
18) Process the OSD display.
19) Read the keyboard. Is the power key pressed?

Main Board Layout

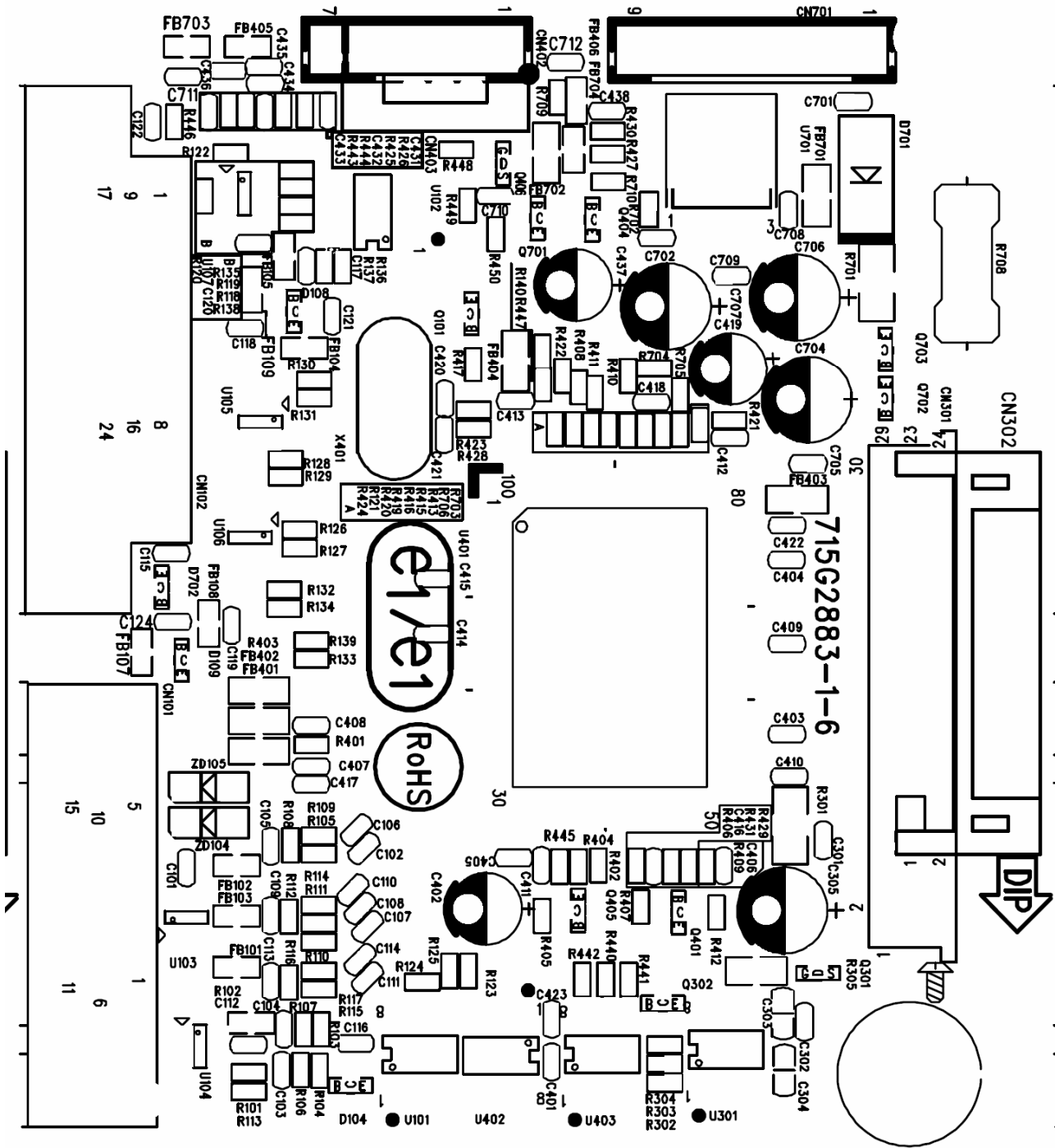

Symbol	Description	Symbol	Description
U401	IC TSUMU58EHL-LF-1	CN402	WAFER
U701	IC AP1117E33L-13	CN701	WAFER 9P RIGHT ANELE PITCH
U106	IC AZC099-04S SOT23-6L	CN301	CONNECTOR
U107	IC AZC099-04S SOT23-6L	X401	14.31818MHZ/32PF/49US0
U403	M24C04-WMN6TP SO8	CN101	D-SUB 15PIN VERTICAL CONN WITH SCREW
U402	SST25VF010A-33-4C-SAE	CN102	DVI 24PIN CONN F

Installation

To install the monitor to your host system, please follow the steps as given below:

Steps

1 Connect Video Cable

- a. Make sure both the monitor and computer are powered-OFF.
- b. Connect the VGA video cable to the computer.
- c. Connect the digital cable (only for dual-input models).
 - (1) Make sure both the monitor and computer are switched off.
 - (2) Connect one end of the 24-pin DVI cable to the back of the monitor and the other end to the computer's port.

2 Connect power cord

Connect the power cord to the monitor, then to a properly grounded AC outlet.

3 Turn on the monitor and computer

Turn on the monitor first, then the computer. This sequence is very important.

- 4 If the monitor still does not function properly, please refer to the troubleshooting section to diagnose the problem.

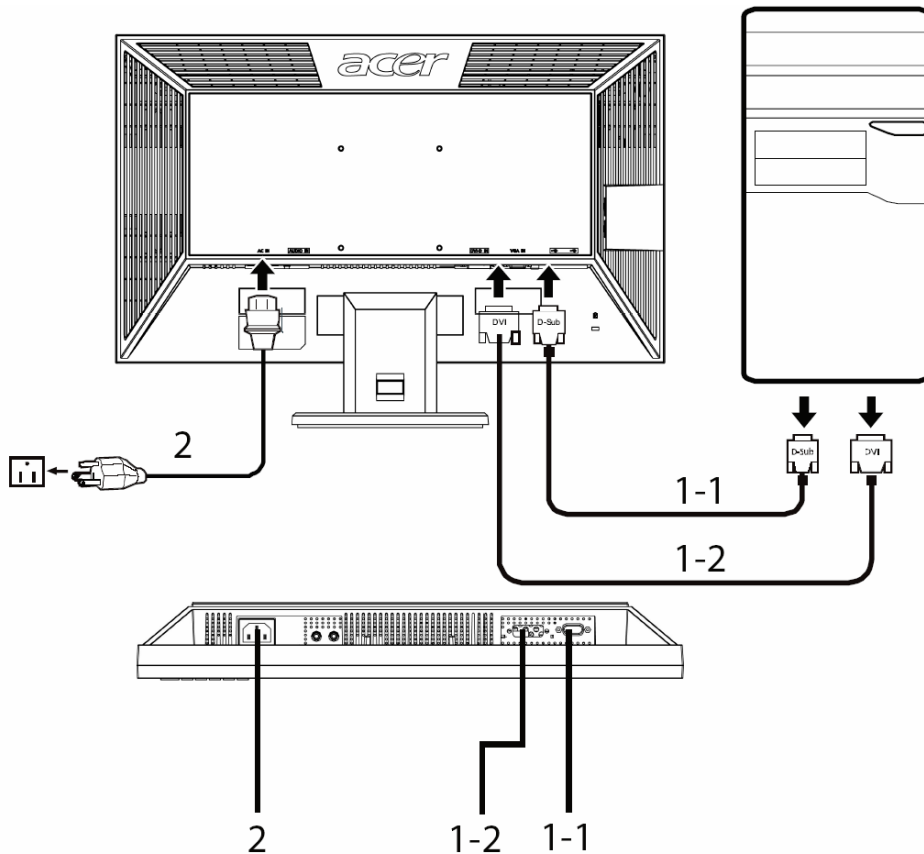

Attaching / Removing the Base

Attaching:

Align the release button on the bottom of the monitor with the corresponding slots on the bottom of the base.

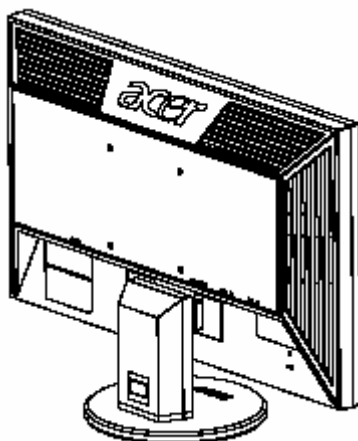

Removing:

Press the release button as indicated, then pull in the direction of the arrow to remove the base.

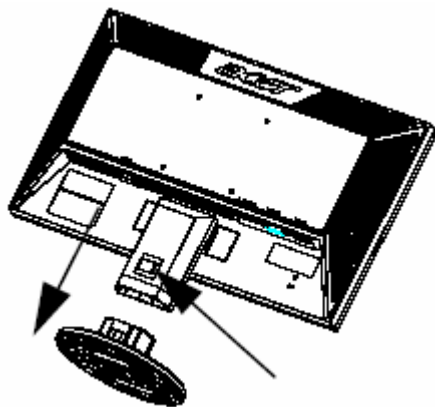

SCREEN POSITION ADJUSTMENT

To optimize the viewing position, you can adjust the monitor tilt by using both of your hands to hold the edges of the monitor as shown below. The monitor can be adjusted to 15 degrees up or 5 degrees down.

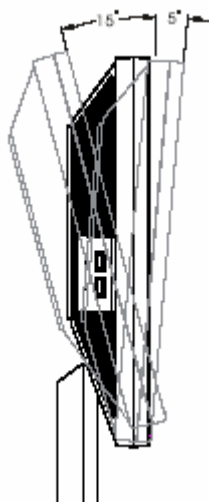

Press the power button to turn the monitor on or off. The other control buttons are located at front panel of the monitor. By changing these settings, the picture can be adjusted to your personal preferences.

- The power cord should be connected.
- Connect the video cable from the monitor to the video card.
- Press the power button to turn on the monitor position. The power indicator will light up.

User Controls

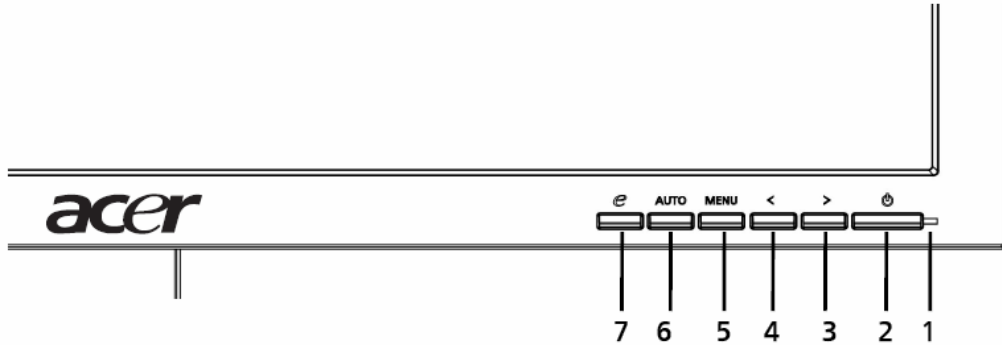

Front panel controls

1. Power LED	Lights up to indicate the power is turned on.
2. Power Switch:	Turn the power on or off.
3.4 < / >	Press < or > to navigate to the desired function, press Enter to select the function. Press < or > to change the settings of the current function.
4. Menu/Enter	Activate the OSD menu when the OSD is off or activate/deactivate the adjustment function when the OSD is on.
6. Auto adjust button/Exit:	a. When the OSD menu is active, this button will act as the exit key (exit OSD menu). b. When the OSD menu is inactive, press this button for two seconds to activate the Auto Adjustment function. The Auto Adjustment function is used to set the HPos, VPos, Clock and Focus.
7. e /Exit	a. When the OSD menu is active, this button will act as the exit key (exit OSD menu). b. When the OSD menu is inactive, press this button to select scenario mode.

eColor Management (OSD)

If selected to “Acer eColor Management” item, will appear the Acer eColor OSD (NOTE: In MENU OSD the “Acer eColor Management” item doesn’t have Multi-language selection, only English language)

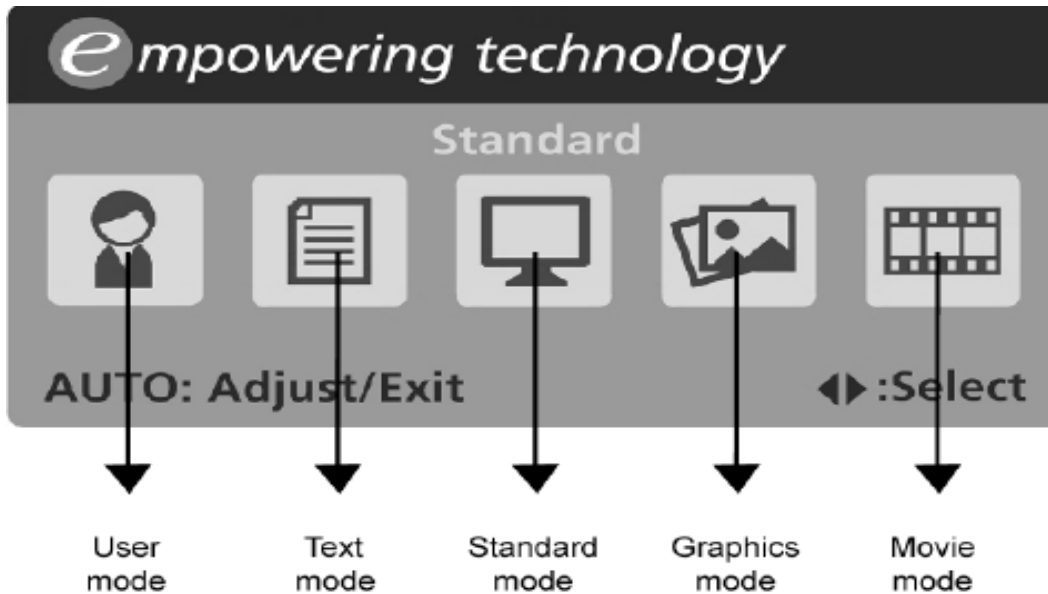

Acer eColor Management main menu, sub menu and description

Main Menu icon	Sub Menu icon	Sub Menu item	Description
	N/A	User mode	User defined. Settings can be fine-tuned to suit any situation
	N/A	Text mode	Optimal balance of brightness and contrast prevent eyestrain. The most comfortable way to read onscreen text
	N/A	Standard mode	Default Setting. Reflects native display capability
	N/A	Grahpic mode	Enhances colors and emphasize fine detail
	N/A	Movie mode	Displays scenes in clearest detail. Pictures and photographs appear in vibrant colors with sharp detail)

How to Adjust a Setting

1. Press the MENU-button to activate the OSD window.
2. Press < or > to select the desired function.
3. Press the MENU-button again to select the function that you want to adjust.
4. Press < or > to change the settings of the current function.
5. To exit and save, select the exit function. If you want to adjust any other function, repeat steps 2-4.

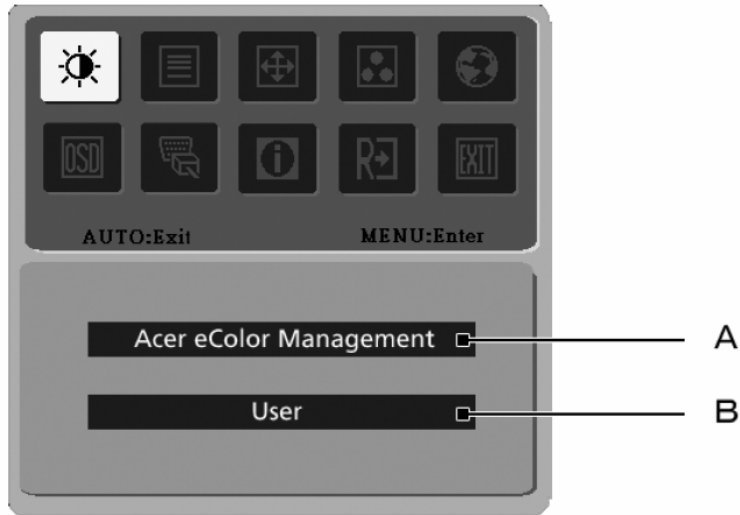

A. Acer eColor Management: If "Acer eColor Management" is selected, the Acer eColor Management OSD will appear.

B. User: If "User" is selected, the standard OSD will appear.



I. Only analog-input mode



II. Only digital-input mode

Acer eColor Management

Operation instructions



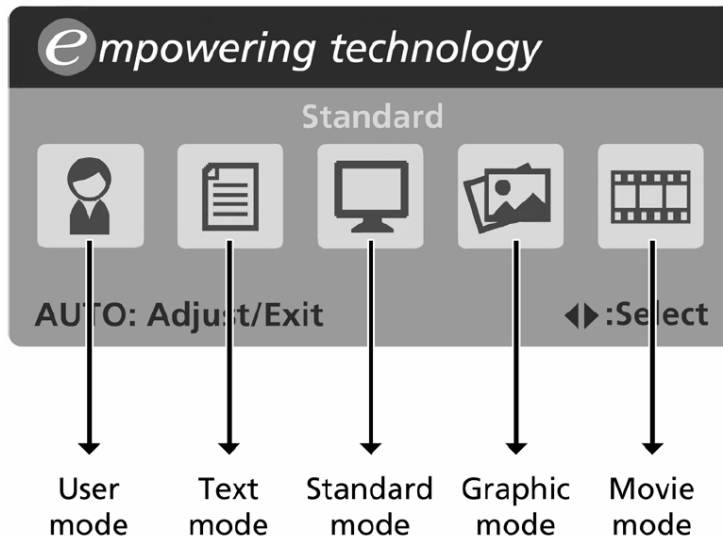











- 1 Press the Empowering Key to open the Acer eColor Management OSD and access the scenario modes.
- 2 Press "<" or ">" to select the mode.
- 3 Press the Auto-adjust button to confirm the mode and run Auto Adjust.











Features and benefits

Main menu icon	Sub menu item	Description
	User mode	User-defined. Settings can be fine-tuned to suit any situation.
	Text mode	Optimal balance of brightness and contrast to prevent eyestrain. The most comfortable way to read onscreen text.
	Standard mode	Default settings. Reflects native display capability.
	Graphic mode	Enhances colors and emphasizes fine detail. Pictures and photographs appear in vibrant colors with sharp detail.
	Movie mode	Displays scenes in clearest detail. Presents great visuals, even in unsuitably-lit environments.

USER main menu, sub menu and description

Main Menu icon	Sub Menu icon	Sub Menu item	Description
		Contrast	Adjust the contrast between the foreground and background of the screen image
		Brightness	Adjust the background brightness of the screen image
		ACM	ACM (Adaptive Contrast Management) ACM ON/OFF Switch, default "OFF"
		Focus	Adjust picture Focus (available in analog mode only)
		Clock	Adjust picture Clock (available in analog mode only)
		H. Position	Adjust the horizontal position. (available in Analog mode only)
		V. Position	Adjust the vertical position. (available in Analog mode only)
	N/A	Warm	Set the color temperature to warm white.
	N/A	Cool	Set the color temperature to cool white.
		User /Red	Adjusts Red/Green/Blue intensity.
		User /Green	
		User /Blue	

	N/A	English	Multi-language selection.
	N/A	繁體中文	
	N/A	Deutsch	
	N/A	Francais	
	N/A	Espanol	
	N/A	Italiano	
	N/A	简体中文	
	N/A	日本語	
	N/A	Suomi	EMEA version OSD only
	N/A	Nederlands	
N/A	Рысскнн		

		H. Position	Adjust the horizontal position of the OSD.
		V. Position	Adjust the vertical position of the OSD.
		OSD Timeout	Adjust the OSD timeout.
	N/A	Analog	Select input signal from analog (D-Sub)
	N/A	Digital (only Dual-Input Model)	Select input signal from digital(DVI) (only Dual-Input Model)
	N/A	DDC/CI	Turn ON/OFF DDC/CI support
	N/A	Information	Show the resolution, H/V frequency and input port of current input timing.
	N/A	Reset	Clear each old status of Auto-configuration and set the color temperature to Warm
	N/A	Exit	Save user adjustment and OSD disappear.

How to Optimize The DOS-Mode

Plug And Play

Plug & Play DDC2B Feature

This monitor is equipped with VESA DDC2B capabilities according to the VESA DDC STANDARD. It allows the monitor to inform the host system of its identity and, depending on the level of DDC used, communicate additional information about its display capabilities.

The DDC2B is a bi-directional data channel based on the I²C protocol. The host can request EDID information over the DDC2B channel.

This monitor will appear to be non-functional if there is no video input signal. In order for this monitor to operate properly, there must be a video input signal.

This monitor meets the Green monitor standards as set by the Video Electronics Standards Association (VESA) and/or the United States Environmental Protection Agency (EPA) and The Swedish Confederation Employees (NUTEK). This feature is designed to conserve electrical energy by reducing power consumption when there is no video-input signal present. When there is no video input signals this monitor, following a time-out period, will automatically switch to an OFF mode. This reduces the monitor's internal power supply consumption. After the video input signal is restored, full power is restored and the display is automatically redrawn. The appearance is similar to a "Screen Saver" feature except the display is completely off. Pressing a key on the keyboard, or clicking the mouse restores the display.

Using the Right Power Cord

The accessory power cord for the Northern American region is the wallet plug with NEMA 5-15 style and is UL listed and CSA labeled. The voltage rating for the power cord shall be 125 volts AC.

Supplied with units intended for connection to power outlet of personal computer: Please use a cord set consisting of a minimum No. 18 AWG, type SJT or SVT three conductors flexible cord. One end terminates with a grounding type attachment plug, rated 10A, 250V, and CEE-22 male configuration. The other end terminates with a molded-on type connector body, rated 10A, 250V, having standard CEE-22 female configuration.

Please note that power supply cord needs to use VDE 0602, 0625, 0821 approval power cord in European countries.

Enter into the factory mode:

Turn off the power, press the "e-color" and turn the power on. The factory OSD will be at the left top of the panel.

This chapter contains step-by-step procedures on how to disassemble the monitor-V233H for maintenance.

The tool for disassembly is as follows:

Screwdriver, Hexagonal screwdriver, Putty knife.

Disassembly Procedure

1. Lay the monitor on a flat, soft and clean surface.



2. Remove the two piece of cover hinge and the four screws remarked in red to remove the hinge assembly.

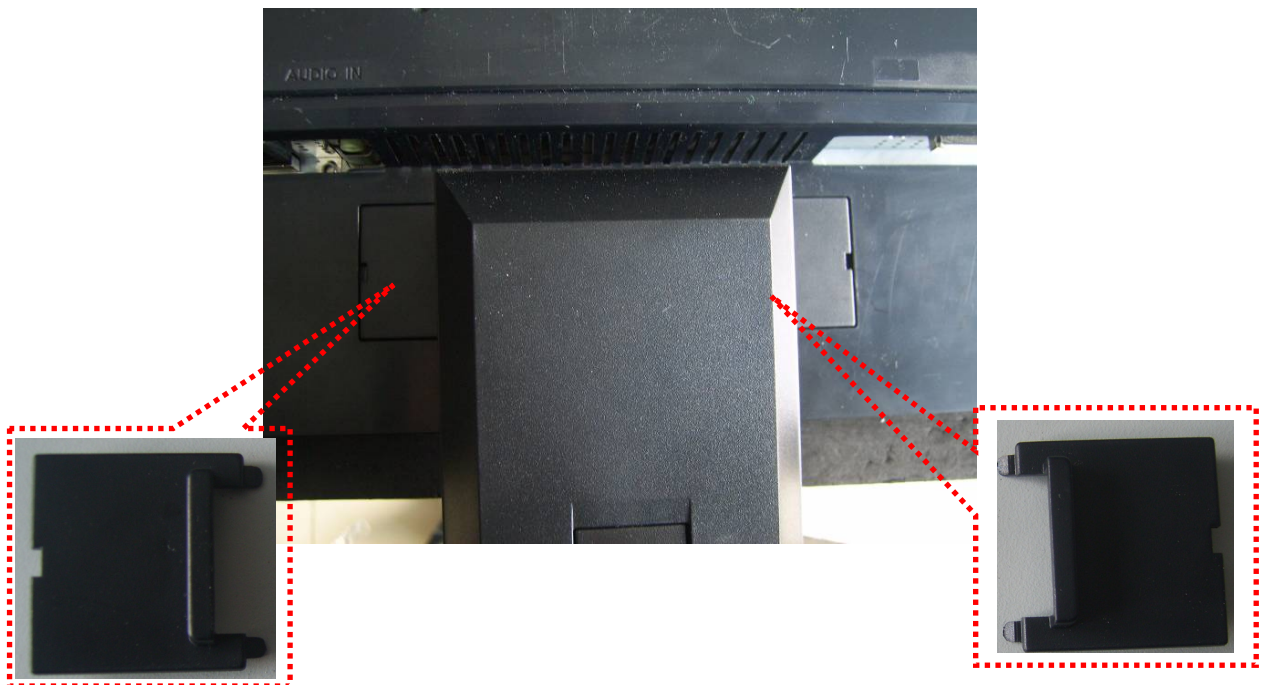



3.Remove the rear cover and bezel.

a.Turn over the monitor and take off the rear cover.Pry the monitor up then find out the hooks' position, use the tool (like the picture or other card) to insert into the gap of bezel and rear cover.



b.Disconnect the connector remarked in green.

PS: be careful to Disconnect the Key board connector, because the keyboard connector maybe damage.

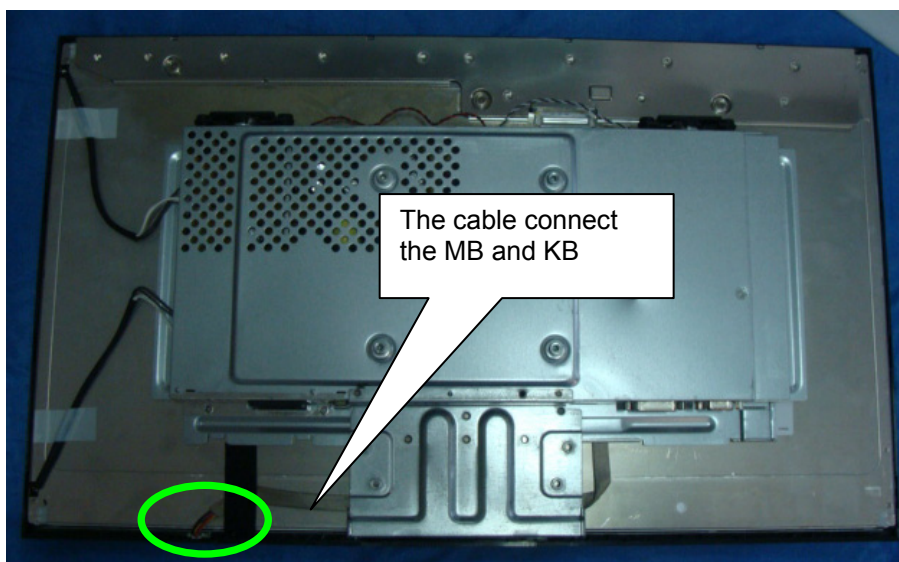

c.Remove the key board from the bezel

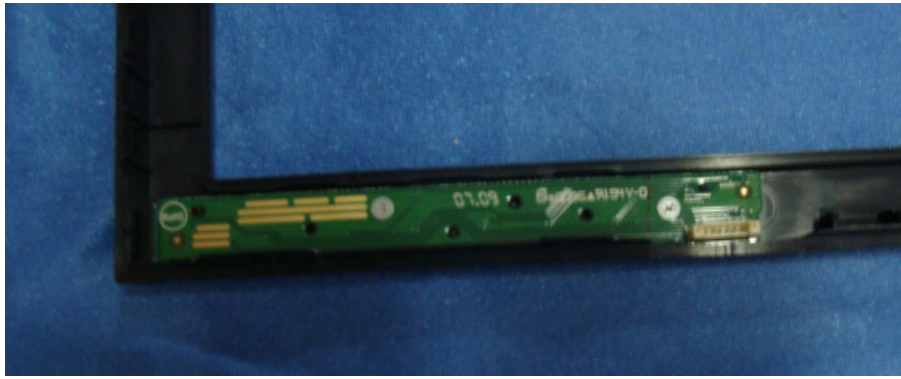

4. Remove the lamp connectors to remove the panel. Put attention to the LVDS cable.

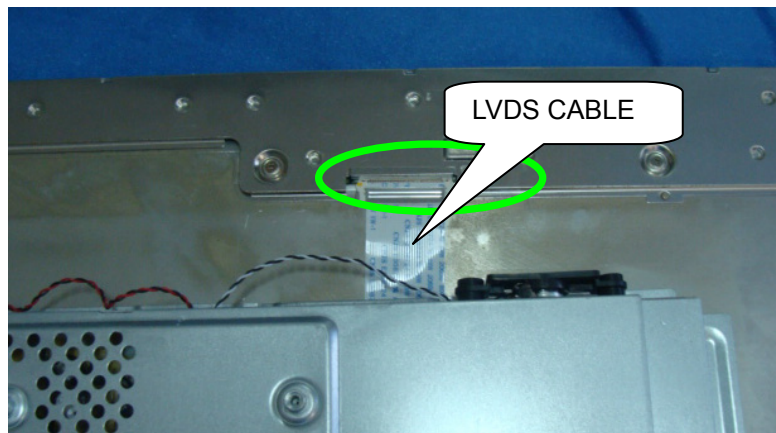
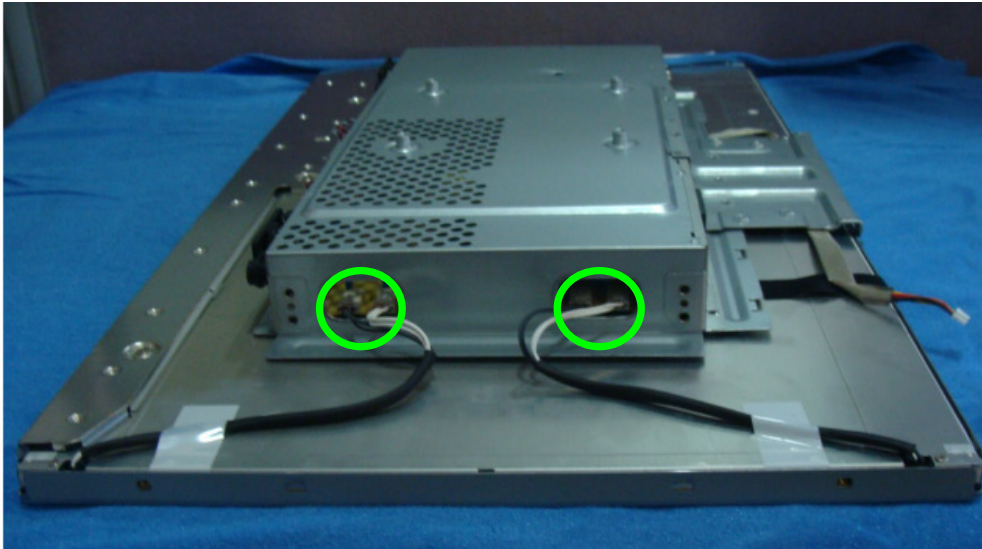

5. Remove the screws remarked in red.

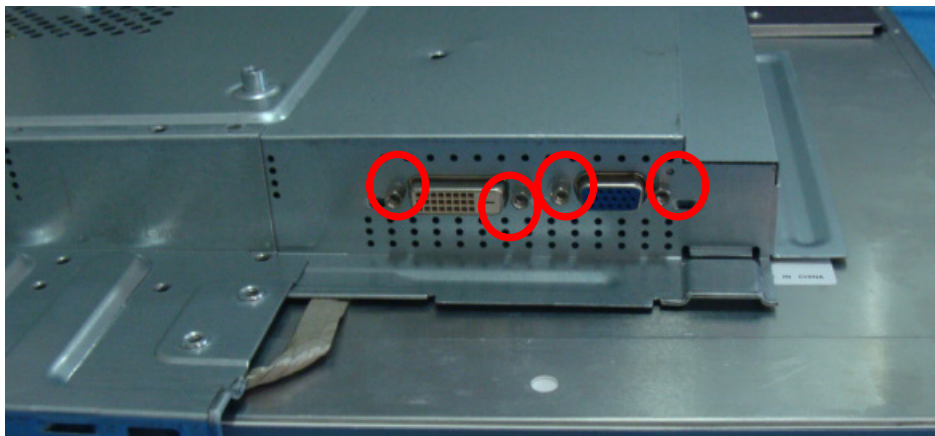

6. Remove the four screws remarked in red and disconnected remarked in green to remove the main board and power board.

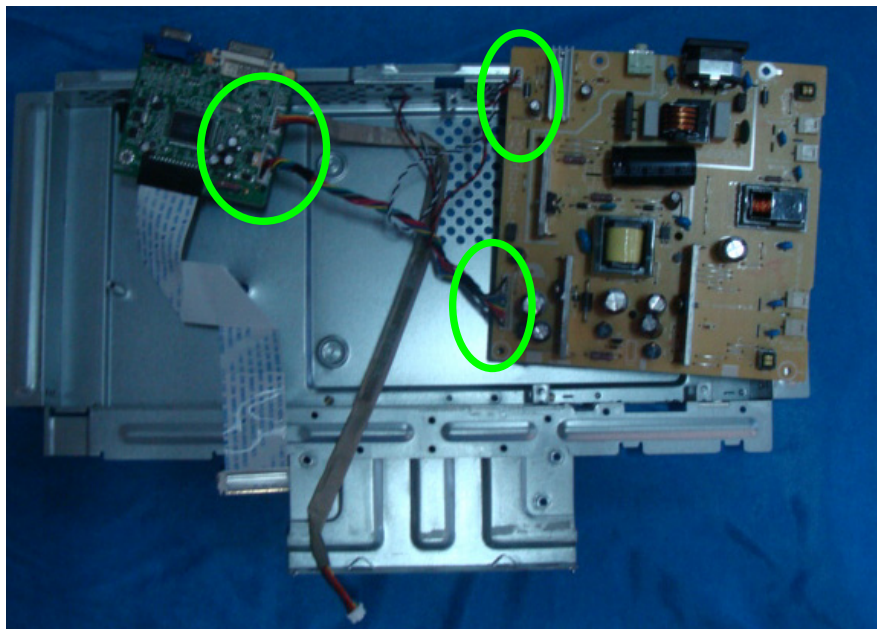
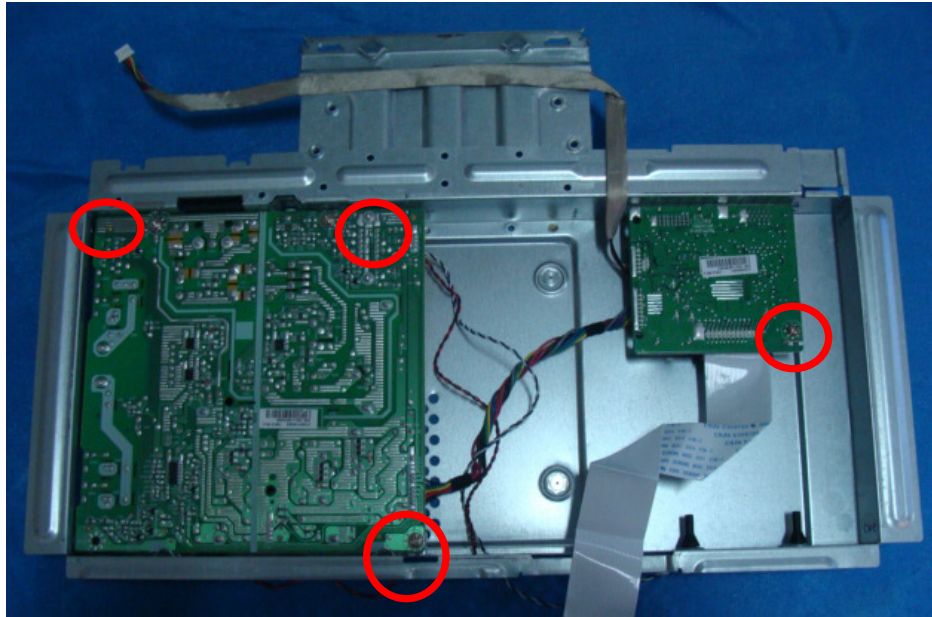

7. The panel

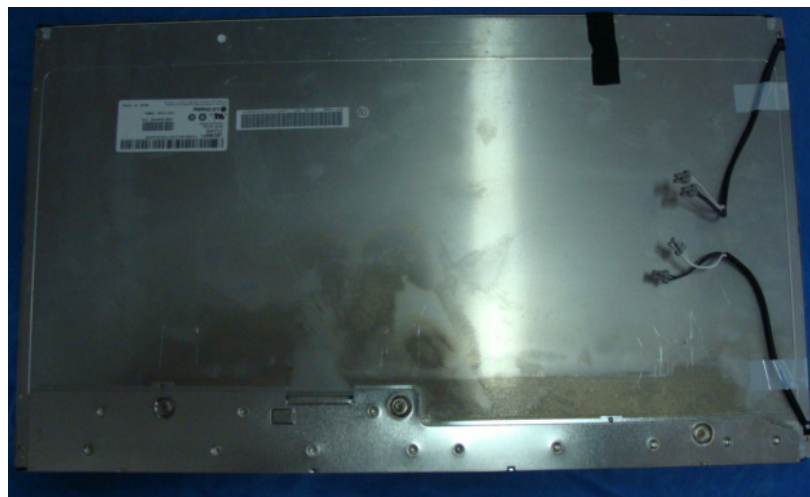

This chapter provides troubleshooting information for the V233H:

1. No Power

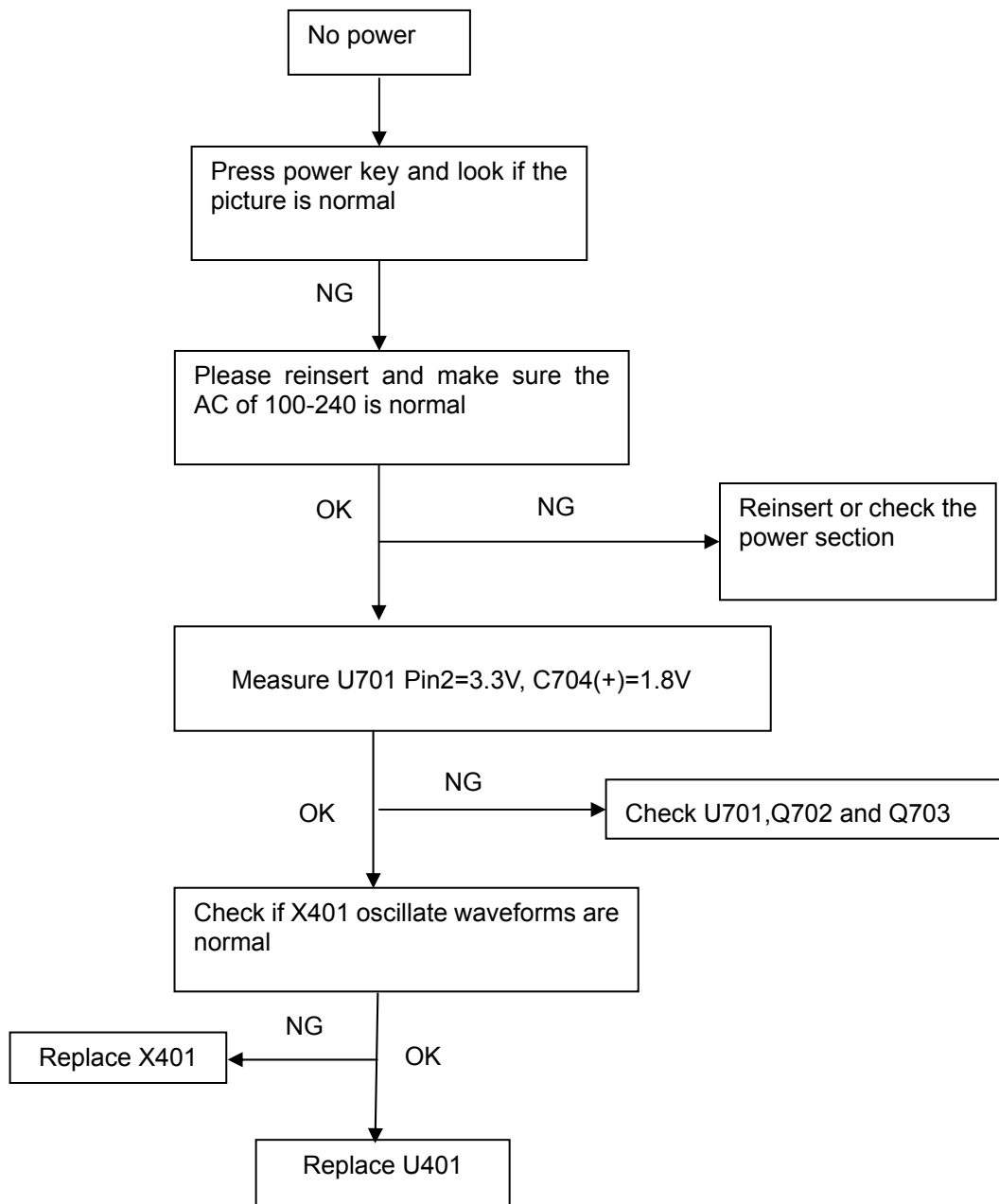

2. No Picture (LED is orange)

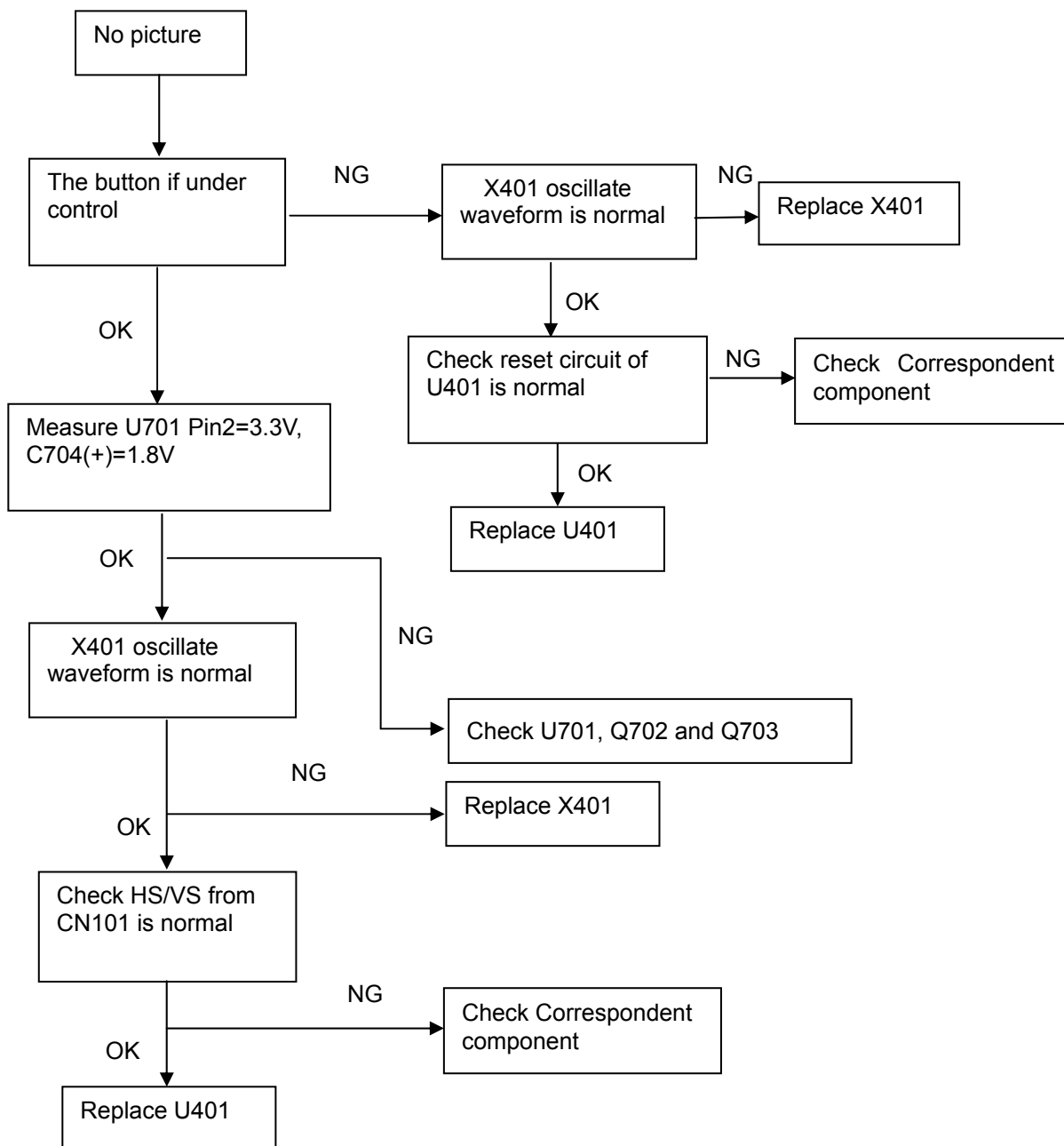

3. Panel Power Circuit

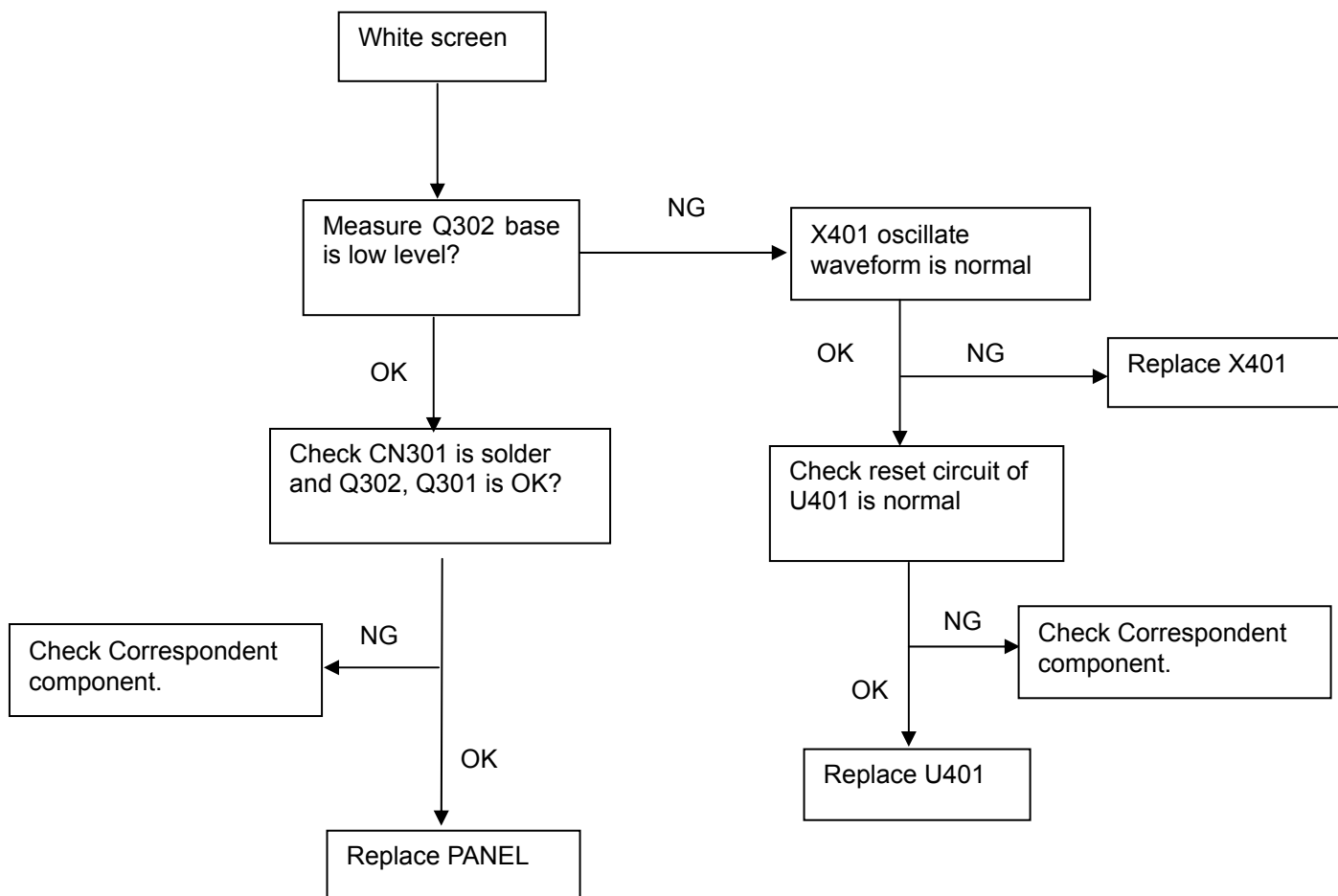

4. Key Board

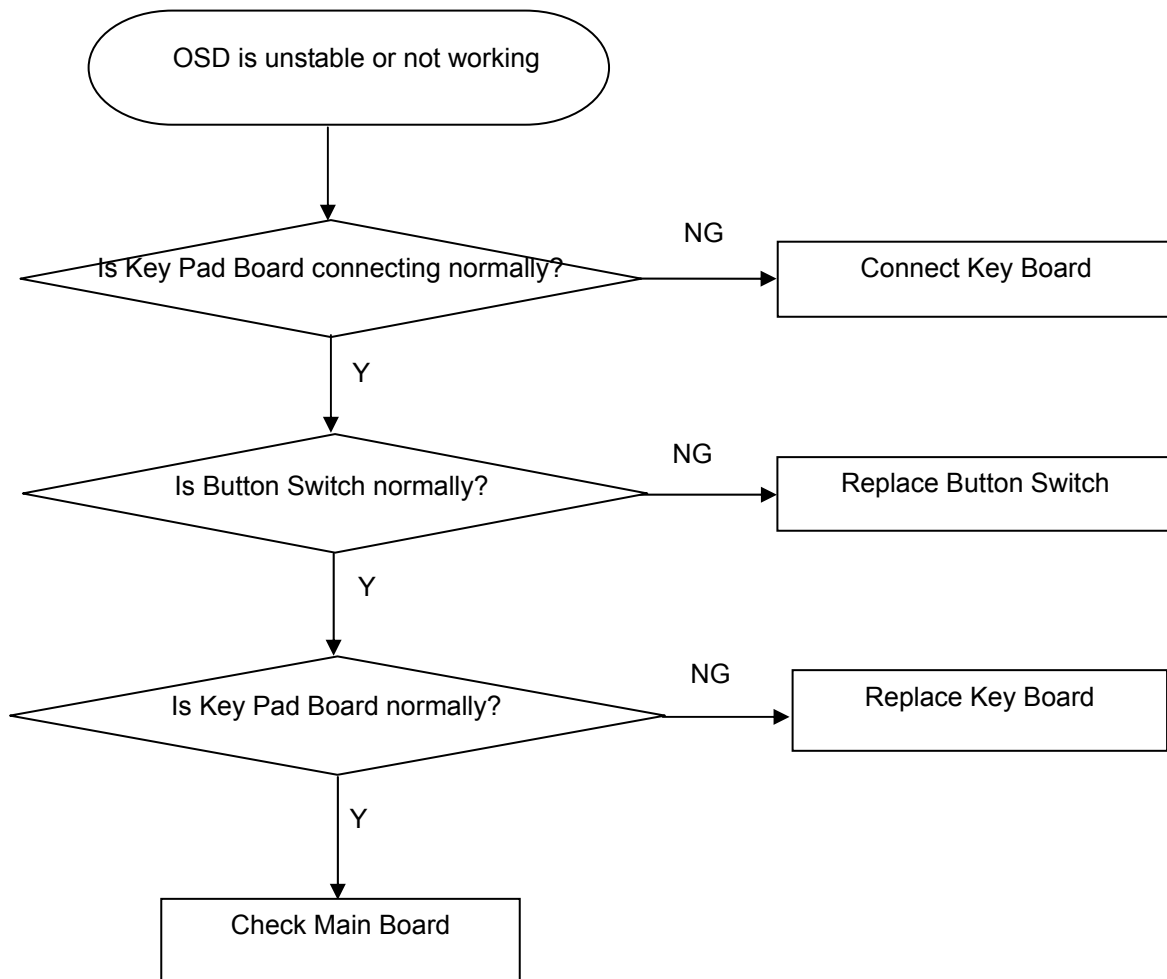

5. Power Board

1) No power

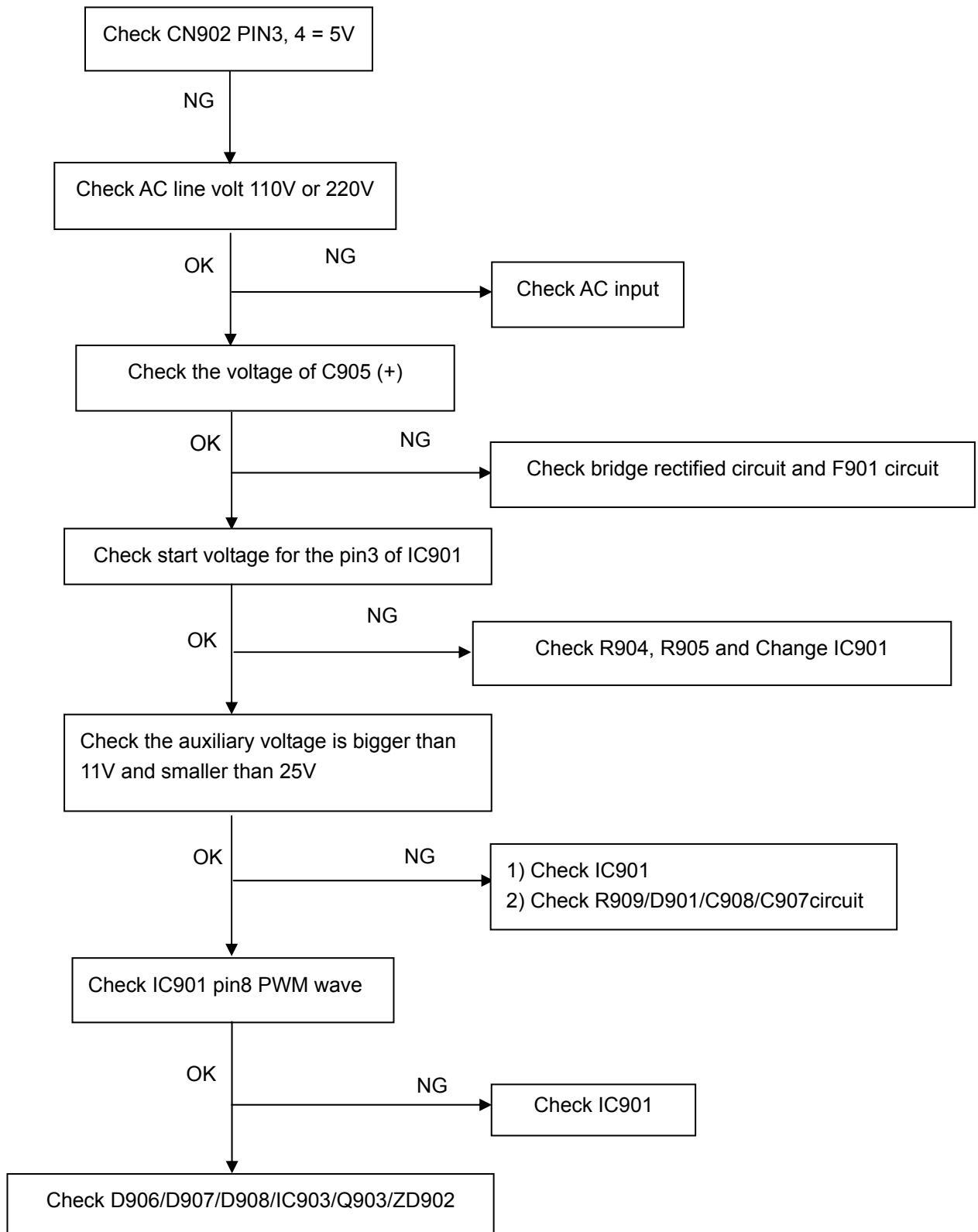

2.) No Backlight

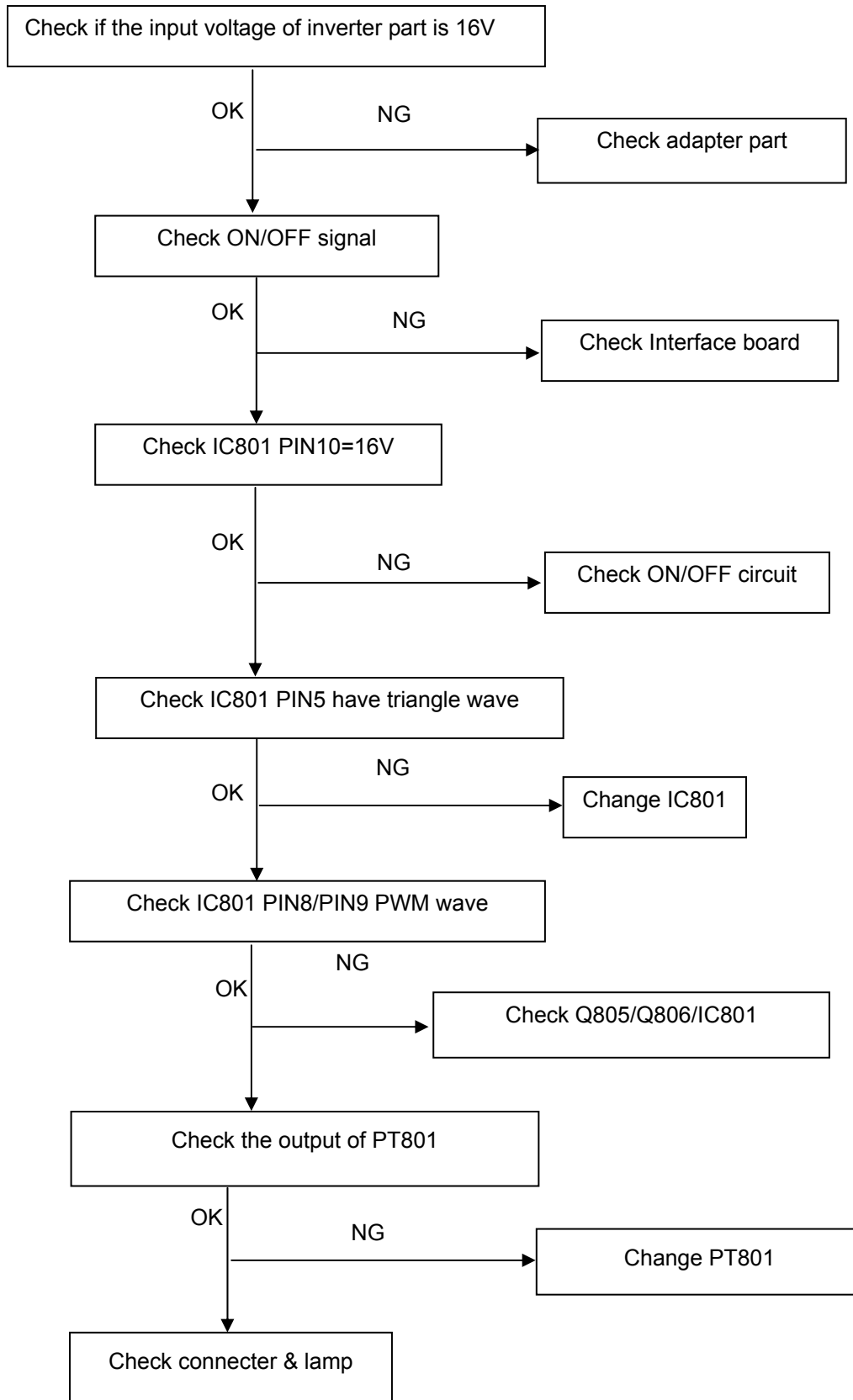

D-sub connect and DVI connect:

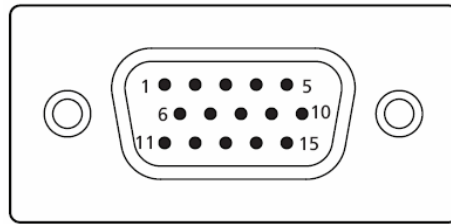

15-Pin Color Display Signal Cable

PIN No.	Description	PIN No.	Description
1	Red	9	+5 V
2	Green	10	Logic ground
3	Blue	11	Monitor ground
4	Monitor ground	12	DDC-serial data
5	DDC-return	13	H-sync
6	R-ground	14	V-sync
7	G-ground	15	DDC-serial clock
8	B-ground		

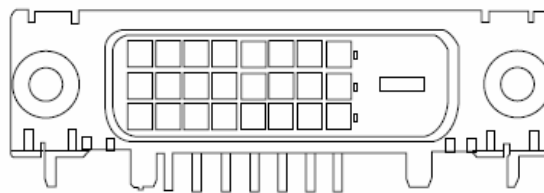

24-Pin Color Display Signal Cable

PIN No.	Description	PIN No.	Description
1	TMDS data 2-	13	NC
2	TMDS data 2+	14	+5 V power
3	TMDS data 2/4 shield	15	GND (return for +5 V hsync.vsync)
4	NC	16	Hot-plug detection
5	NC	17	TMDS data 0-
6	DDC clock	18	TMDS data 0+
7	DDC data	19	TMDS data 0/5 shield
8	NC	20	NC
9	TMDS data 1-	21	NC
10	TMDS data 1+	22	TMDS clock shield
11	TMDS data 1/3 shield	23	TMDS clock+
12	NC	24	DDC TMDS clock-

This chapter gives you the FRU (Field Replaceable Unit) listing in global configurations of V233H. Refer to this chapter whenever ordering for parts to repair or for RMA (Return Merchandise Authorization).

NOTE: Please note WHEN ORDERING FRU PARTS, that you should check the most up-to-date information available on your regional web or channel (<http://aicsl.acer.com.tw/spl/>). For whatever reasons a part number change is made, it will not be noted in the printed Service Guide. For ACER AUTHORIZED SERVICE PROVIDERS, your Acer office may have a DIFFERENT part number code from those given in the FRU list of this printed Service Guide. You MUST use the local FRU list provided by your regional Acer office to order FRU parts for repair and service of customer machines.

NOTE: To scrap or to return the defective parts, you should follow the local government ordinance or regulations on how to dispose it properly, or follow the rules set by your regional Acer office on how to return it.

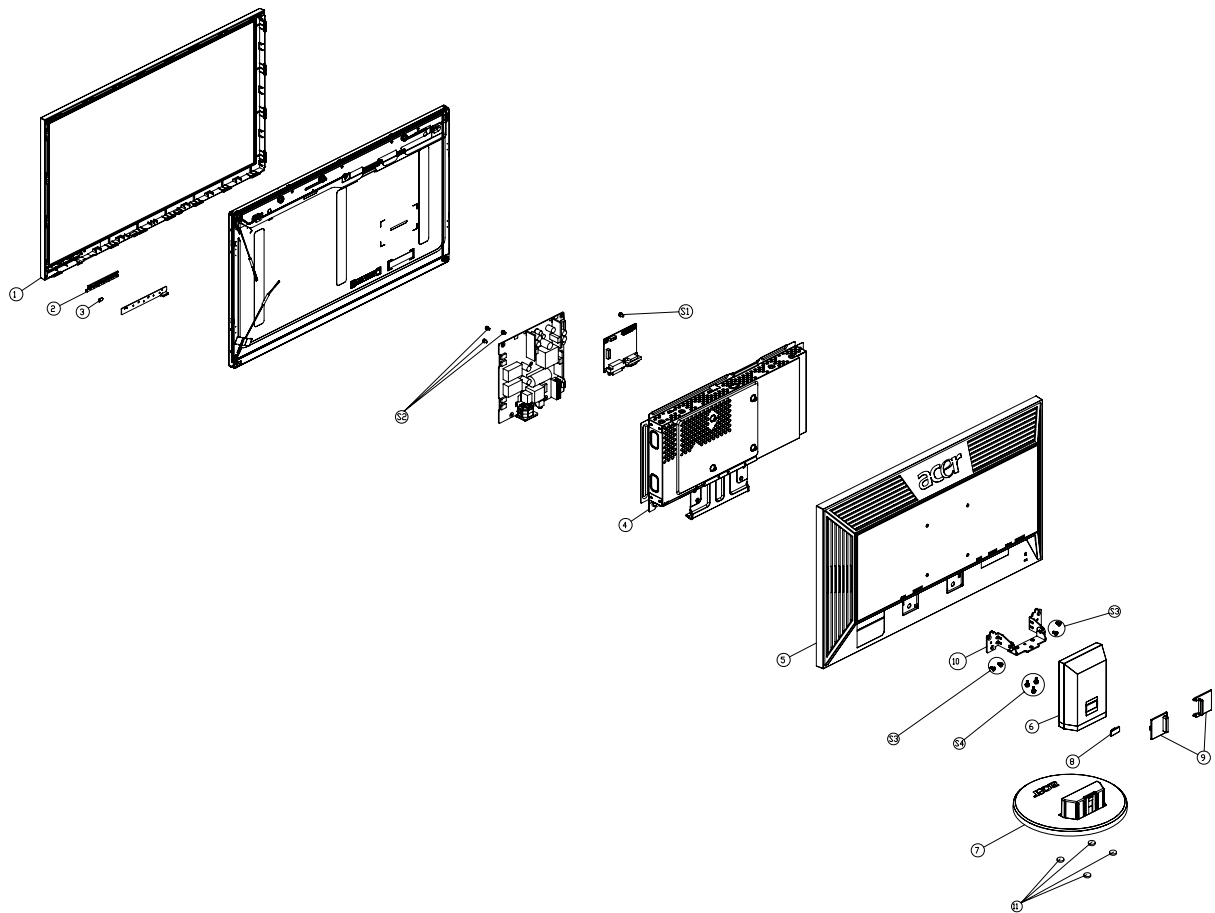

Exploded Diagram (Model: V233H)



Item	Description	TPV Part No.	ACER Part NO.	Q`ty
1	BEZEL L23WA-8ACER1-S2	A34G1338AEMA2B0130	60.LG90B.001	1
2	POWER LENS	A33G0378 1 1C0100		1
3	KEY BUTTON	A33G0379AEM 1L0100		1
4	MAINFRAME	A15G0772302104	60.LG90B.003	1
5	REAR COVER 23WA	A34G1339AEM 9B0100	60.LG90B.002	1
6	STAND	A34G1135AEM 1B0100	60.LF50B.003	1
7	BASE 8ACER1 S2	A34G1136AEM 1B0130	60.LG60B.004	1
8	BUTTON BASE	A33G0380AEM 1L0100		1
9	COVER HINGE	A33G0382AEM 1L0100		1
10	HINGE	A37G0075 2	60.LG60B.006	1
11	FOOT	Q12G6600 6		4
12	SCREW,42-D020523	0M1G1730 6120		1
13	SCREW	0G1G1130 8120		3
14	SCREW	0M1G 140 6125		4
15	SCREW FOR STD/MF	0M1G1740 8120		3

Part List

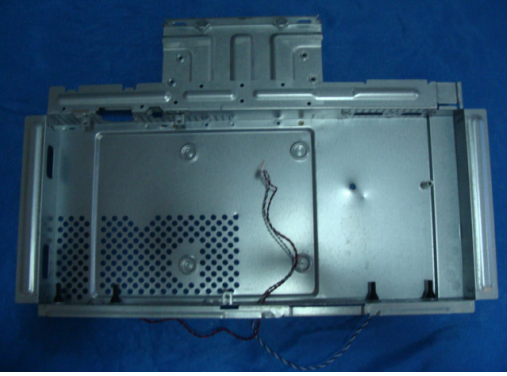
Above picture show the description of the following component.

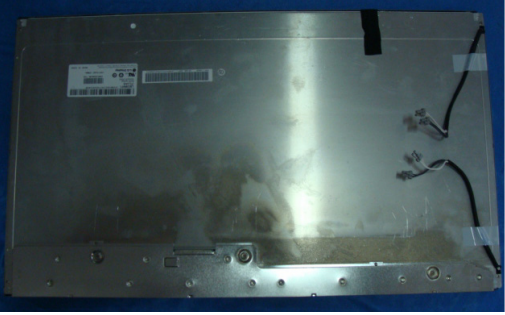
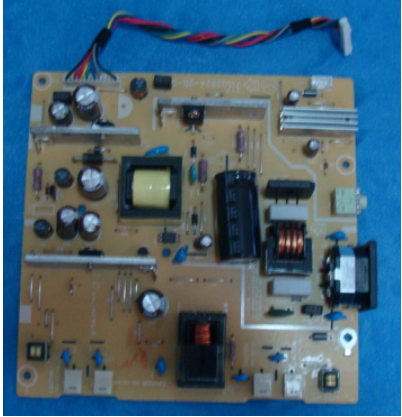
Picture	Description	TPV Part No.	ACER Part NO.
	Main_frame_Sam	A15G0772302104	60.LG90B.003
	Bezel	A34G1338AEMA2 B0130	60.LG90B.001
	Panel	750GLG230F1A3 3N000	55.LG90B.001
	Power Board	PWPC9E41MQKD	19.LF50B.001

	Main Board	CBPC9A8ABQ1	55.LG90B.001
	Key Board	KEPC8QK4	55.LBZ0B.005
	Hinge	A37G0075 2	60.LG60B.006
	base	A34G1136AEM 1B0130	60.LG60B.004

Main Board

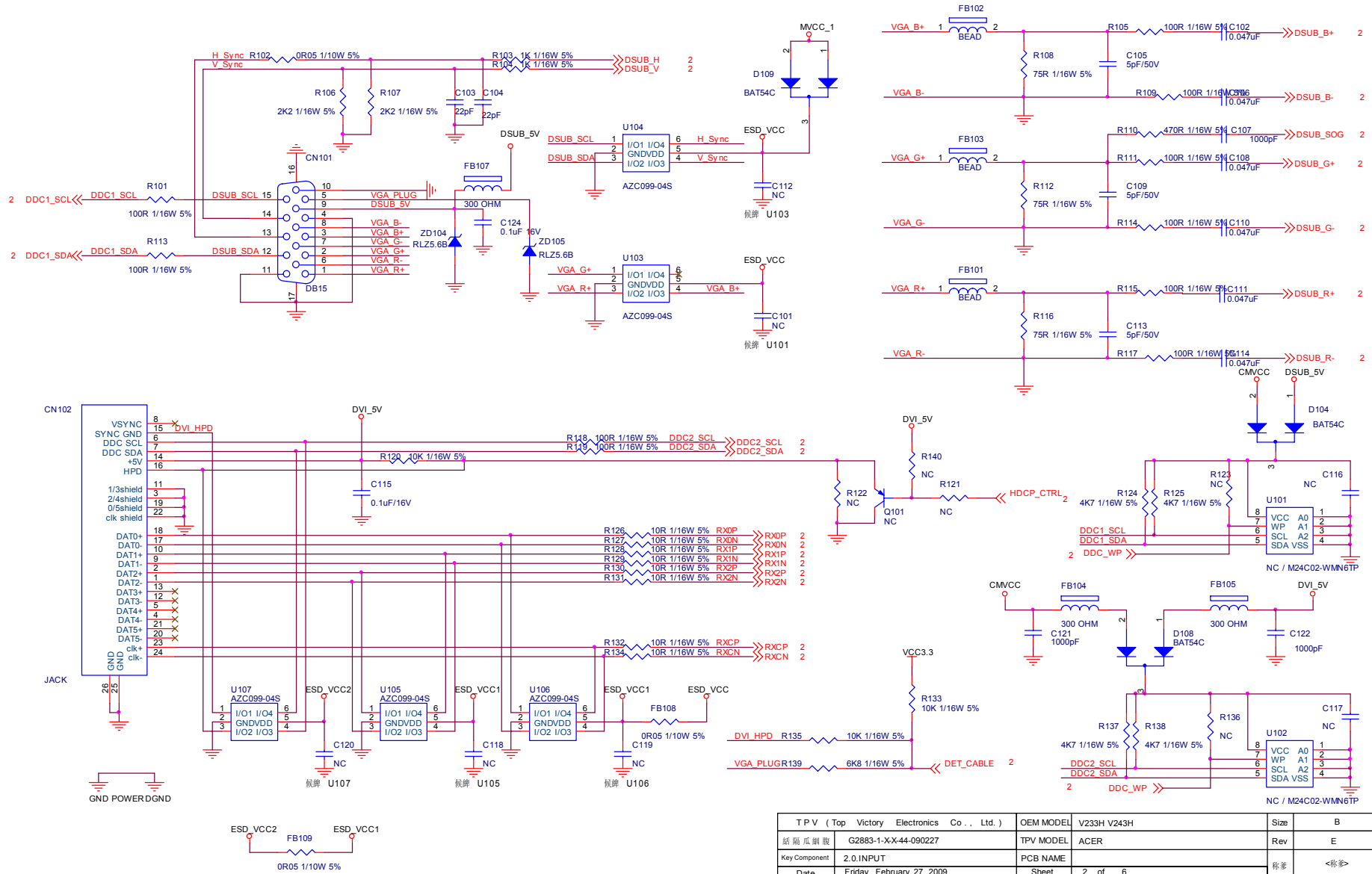

TPV (Top Victory Electronics Co., Ltd.)	OEM MODEL	V233H V243H	Size	B
話 隔 瓜 網 廠	G2883-1-X-X-44-090227	TPV MODEL	ACER	Rev
Key Component	2.0.INPUT	PCB NAME		稱 號
Date	Friday, February 27, 2009	Sheet	2 of 6	<稱 號>

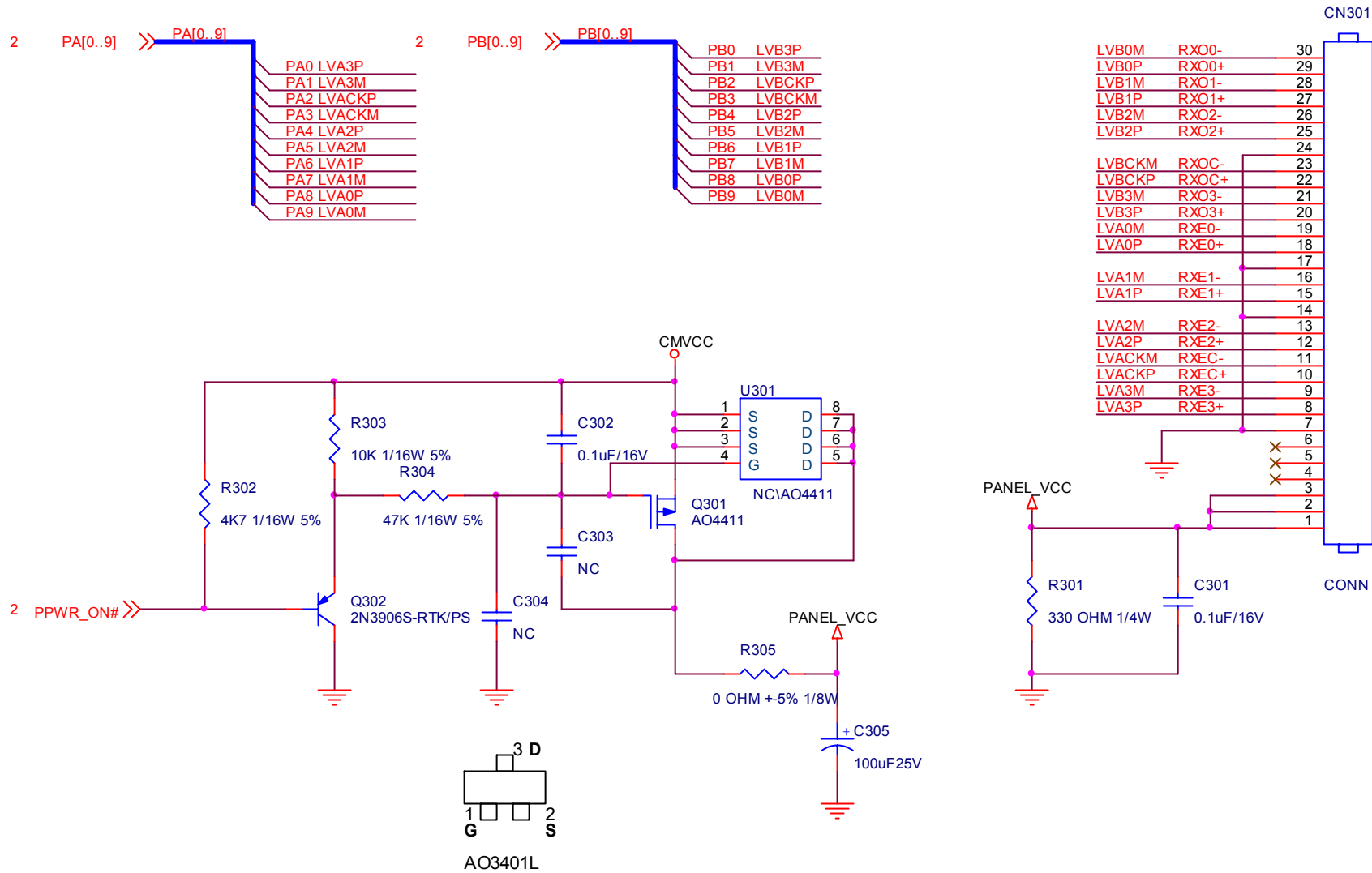

TPV (Top Victory Electronics Co., Ltd.)	OEM MODEL	V233H V243H	Size	A
結隔瓜網腹	G2883-1-X-X-44-090227	TPV MODEL	ACER	Rev
KeyComponent	3.0.OUTPUT	PCB NAME	称爹	<称爹>
Date	Friday, February 27, 2009	Sheet	3 of 6	

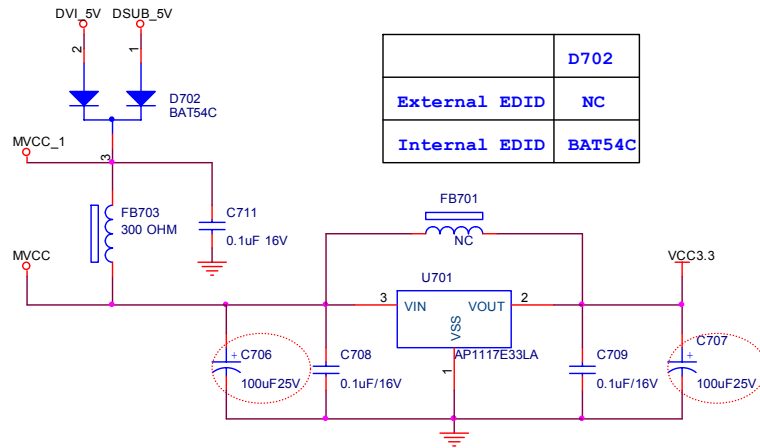
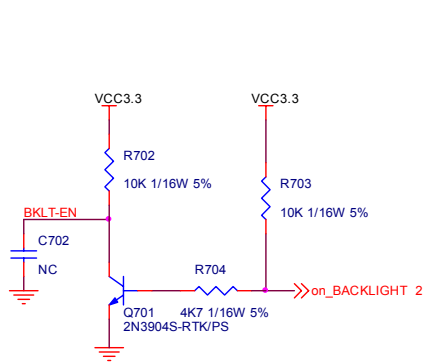
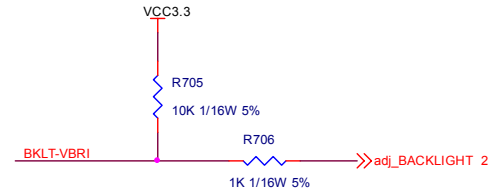
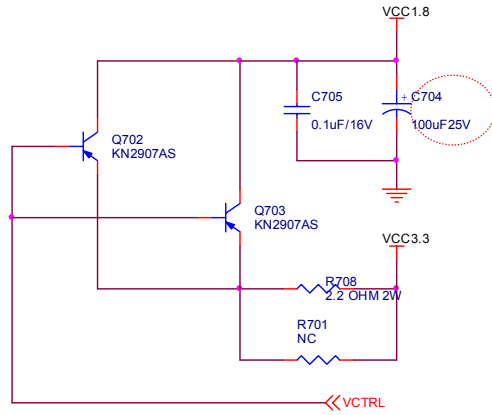
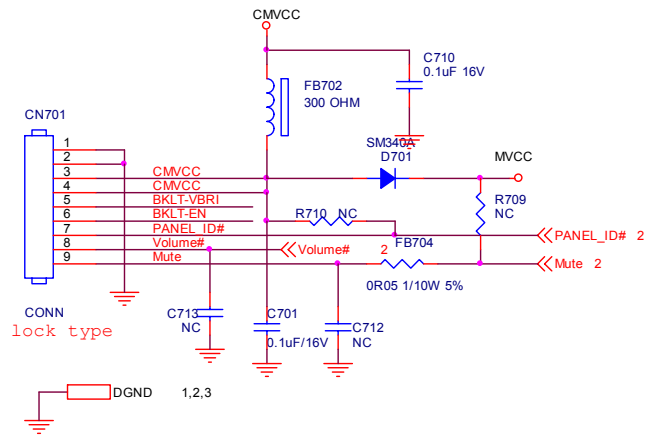

	D702
External EDID	NC
Internal EDID	BAT54C

TPV (Top Victory Electronics Co., Ltd.)	OEM MODEL	V233H V243H	Size	B
絲隔瓜網膜	G2883-1-X-X-44-090227	TPV MODEL	ACER	Rev
Key Component	4.0.POWER	PCB NAME		稱爹
Date	Friday, February 27, 2009	Sheet	4 of 6	<稱爹>

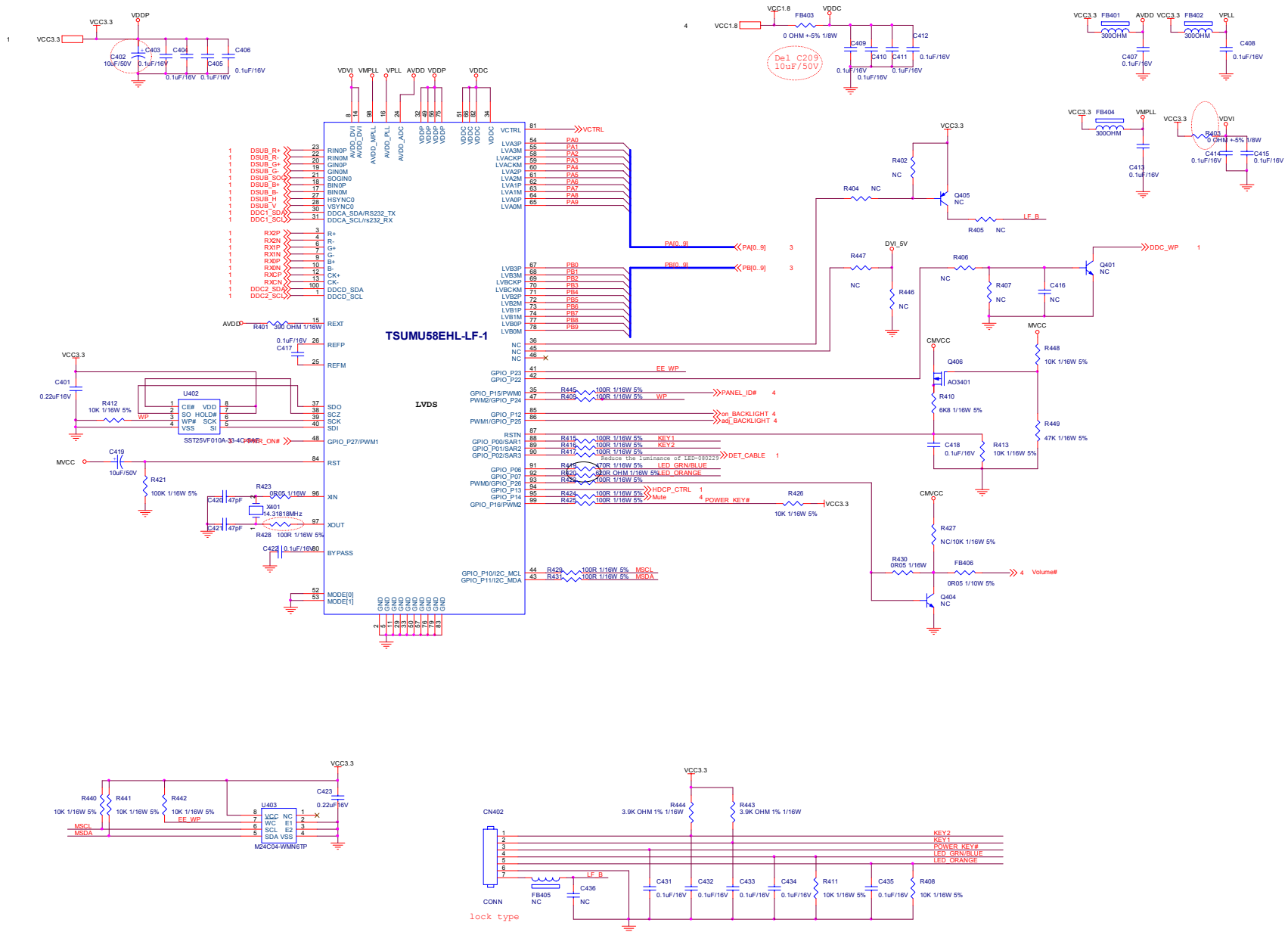

T P V (Top Victory Electronics Co . Ltd .)	OEM MODEL	V233H V243H	Size	C
部 品 代 理 販	G2883-1-X-X-44-090227	TPV MODEL	ACER	Rev
Key Component	5.0.SCALER	PCB NAME		E
Date	Friday, February 27, 2009	Sheet	5 of 6	※※

Power board

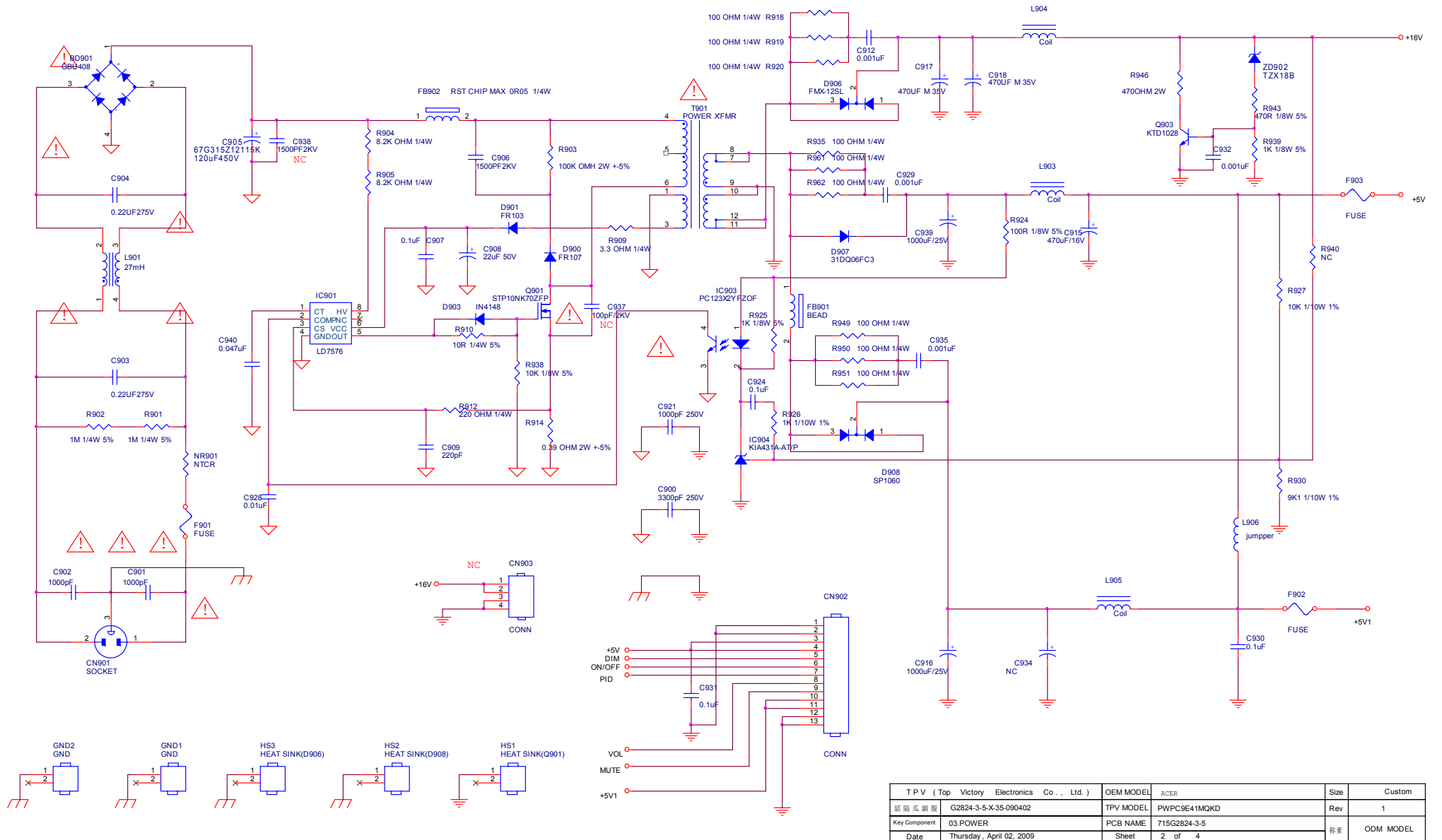

TPV (Top Victory Electronics Co., Ltd.)	OEM MODEL	ACER	Size	Custom
规格书编号: G2824-3-5-X-35-090402	TPV MODEL	PWPC9E41MQKD	Rev	1
Key Component: 03.POWER	PCB NAME	715G2824-3-5	数量	ODM MODEL
Date: Thursday, April 02, 2009	Sheet	2 of 4		

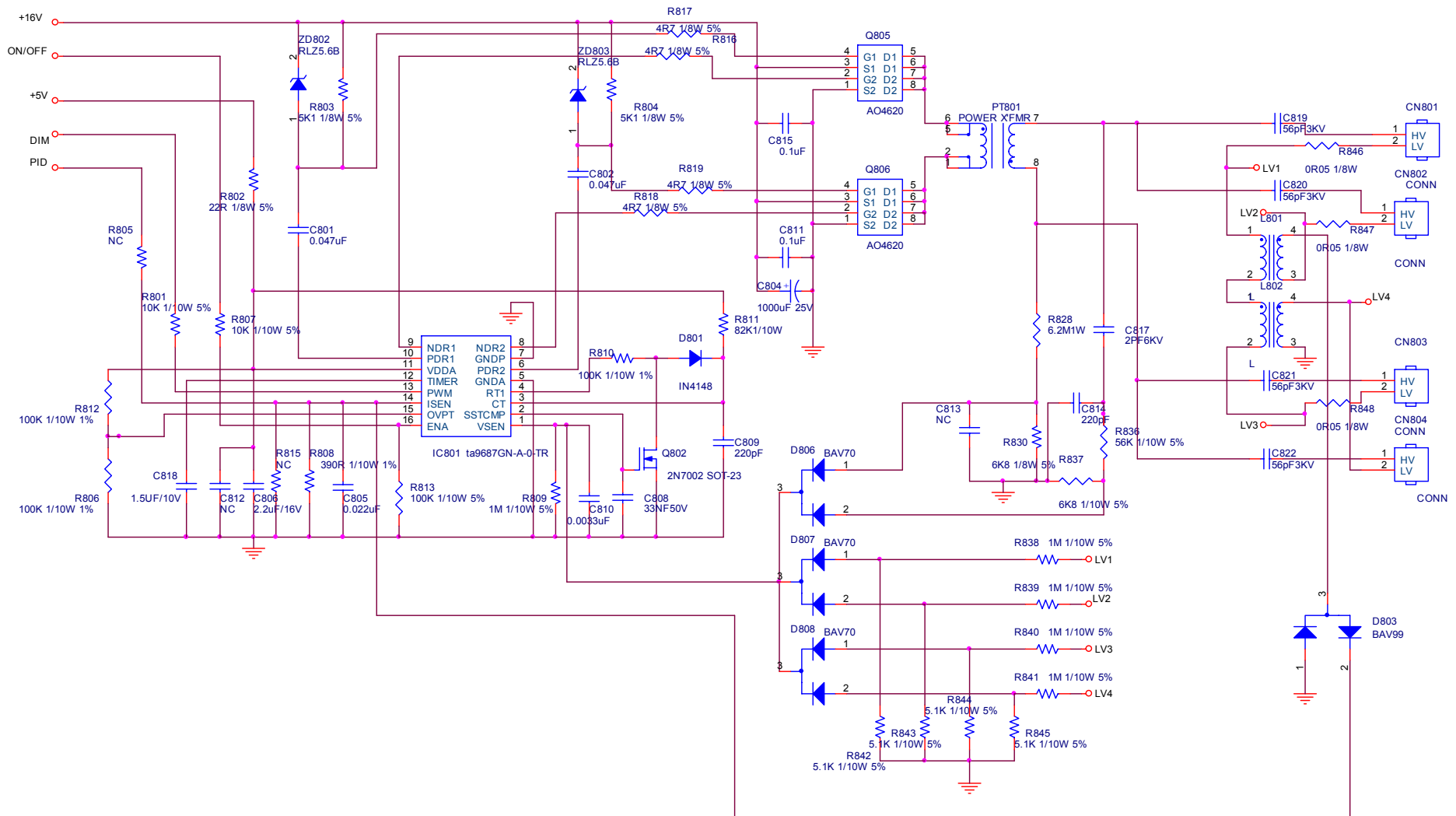

TPV (Top Victory Electronics Co., Ltd.)	OEM MODEL	ACER	Size	Custom
新馬瓜網版	G2824-3-5-X-35-090402	TPV MODEL	PWPC9E41MQKD	Rev 1
Key Component	02.INVERTER	PCB NAME	715G2824-3-5	称参 ODM MODEL
Date	Thursday, April 02, 2009	Sheet	3 of 4	

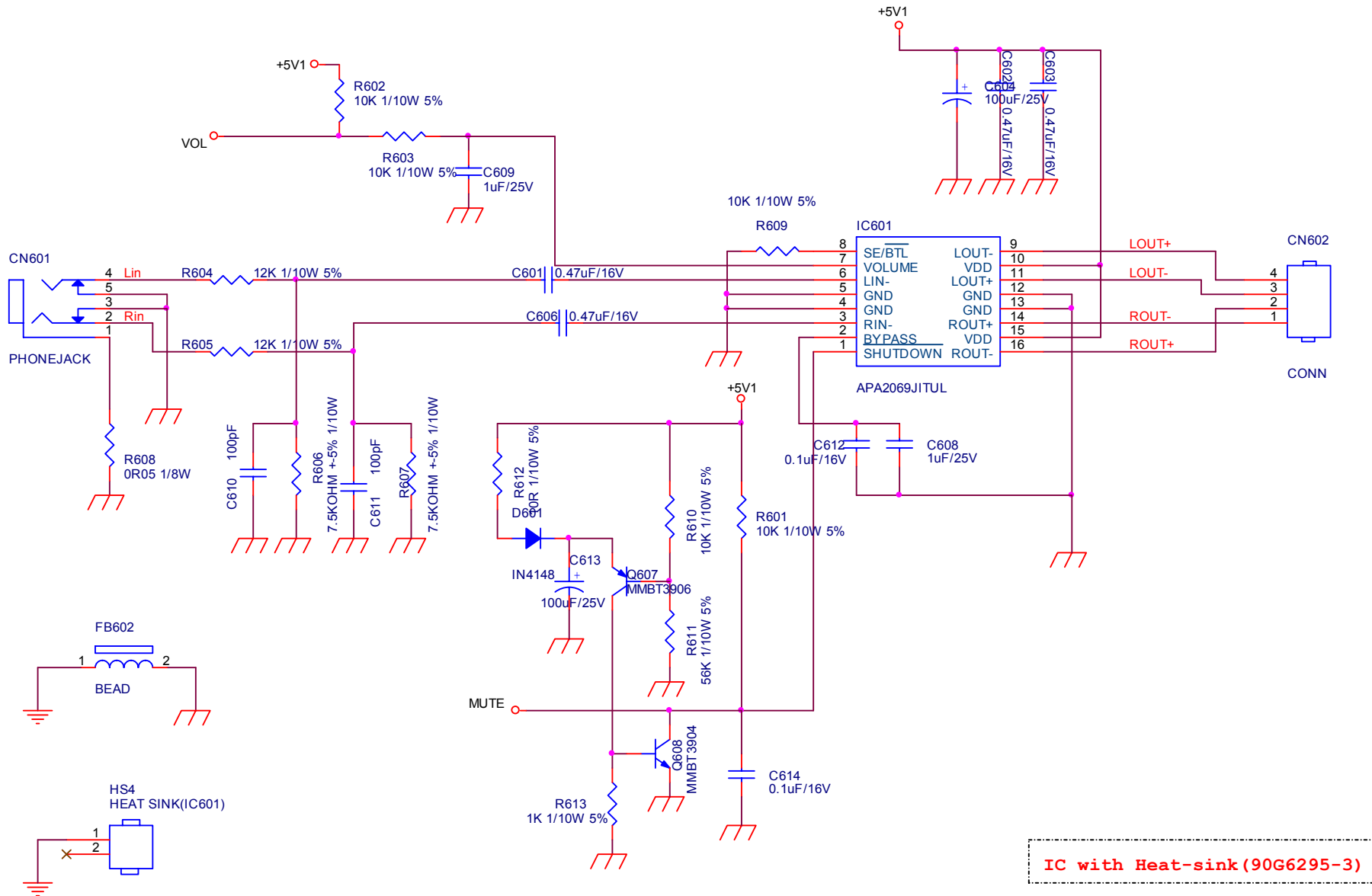

TPV (Top Victory Electronics Co., Ltd.)	OEM MODEL	ACER	Size	Custom
結隔瓜網膜	G2824-3-5-X-35-090402	TPV MODEL	PWPC9E41MQKD	Rev 1
Key Component	04.AUDIO	PCB NAME	715G2824-3-5	称爹 ODM MODEL
Date	Thursday, April 02, 2009	Sheet	4 of 4	

Key board

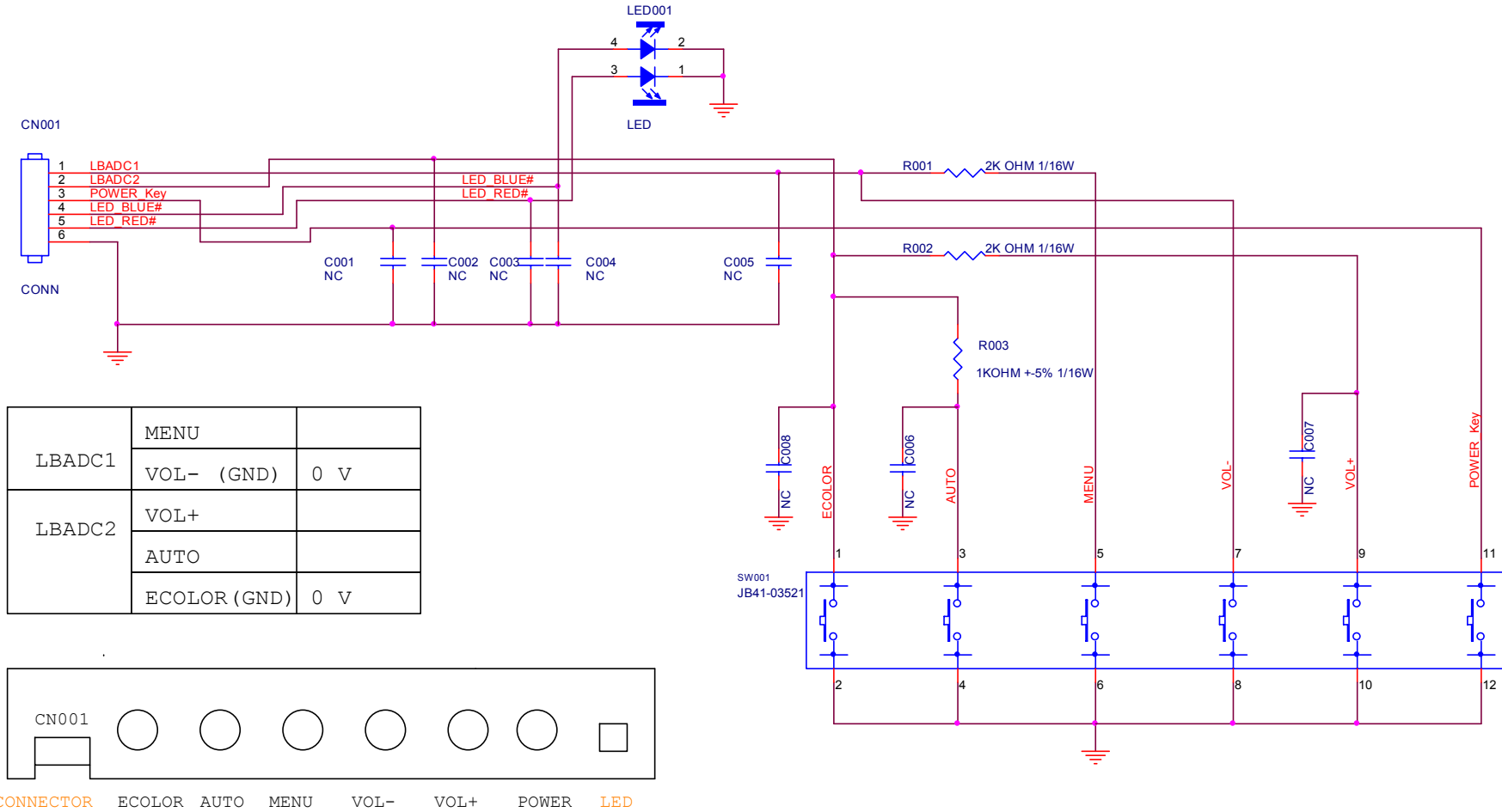

LBADC1	MENU	
	VOL- (GND)	0 V
LBADC2	VOL+	
	AUTO	
	ECOLOR (GND)	0 V

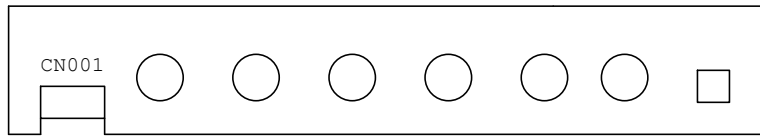

CONNECTOR ECOLOR AUTO MENU VOL- VOL+ POWER LED

TPV (Top Victory Electronics Co., Ltd.)	OEM MODEL	acer B and V key pad	Size	A4
結隔瓜網膜	G2944-A-X-X-1-071122	TPV MODEL	acer	Rev
Key Component	02.KEY	PCB NAME	715G2944-A	称爹
Date	Thursday, November 22, 2007	Sheet	2 of 2	<称爹>