

CONTENTS

WARNING	A
SAFETY PRECAUTIONS	B
DIMENSIONS	1
GENERAL INFORMATION	2
SPECIFICATIONS	3
THEORY OF OPERATION	4
DISASSEMBLY INSTRUCTIONS	5
CONTROL LOCATION	6
NECESSARY EQUIPMENT LIST	7
BLOCK DIAGRAM	8
CONDUCTOR VIEW	9
SCHEMATIC DIAGRAM	10
TROUBLE SHOOTING HINTS	11
REPLACEMENT PARTS LIST	12
SPARE PARTS LIST	13

WARNING

This service information is designed for experienced repair technicians only and is not designd for use by the general public

It does not contain warnings or cautions to advise non-technical individuals of potential dangers in attempting to service a product.

Products powered by electricity should be serviced or repaired only by experienced professional technicians.

Any attempt to service or repair the product or products dealt within this service information by anyone else could result in serious injury or death.

SAFETY PRECAUTIONS

1. CAUTION:

No modification of any circuit should be attempted. Service work should only be performed after you are thoroughly familiar with all of the following safety checks and servicing guide lines.

2. SAFETY CHECK

Care should be taken while servicing this LCD display. Because of the high voltage used in the inverter circuit. These voltage are exposed in such areas as the associated transformer circuits.

3. POWER SUPPLY REQUIREMENTS

The external power converter for this display utilizes AC and DC cords, AC cord is detachable, but DC cord is permanently attached. Any attempt to replace another adapter could result in serious problem on the display.

4. LEAKAGE CURRENT HOT CHECK

4-1 Plug the AC cord directly into the AC outlet.

Do not use an isolation transformer during this check.

4-2 Connect a 1500 ohm, 10 watt resistor, paralleled by a 0.15uF capacitor between each metallic part and a good earth ground.

4-3 Use an AC voltmeter with 1000 ohm / volt or more sensitivity and measure the AC voltage across the combination 1500 ohm resistor and 0.15uF capacitor.

4-4 Move the resistor connection to each exposed metallic part and measure the voltage.

4-5 Reverse the polarity of the AC plug in the AC outlet and repeat the above measurement.

4-6 Voltage measured must not exceed 1.5 volt RMS, from any exposed metallic part to the ground. A leakage current tester may be used in the above hot check, in which case any circuit measured must not exceed 1.0 miliamp. In the case of a measurement exceeding the 1.0 miliamp value, a rework is required to eliminate the chance of a shock hazard.

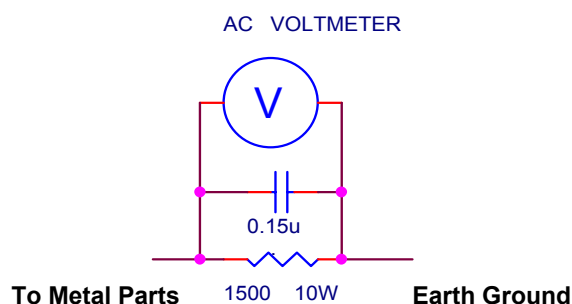

1. DIMENSIONS~1 unit : mm

Front Side

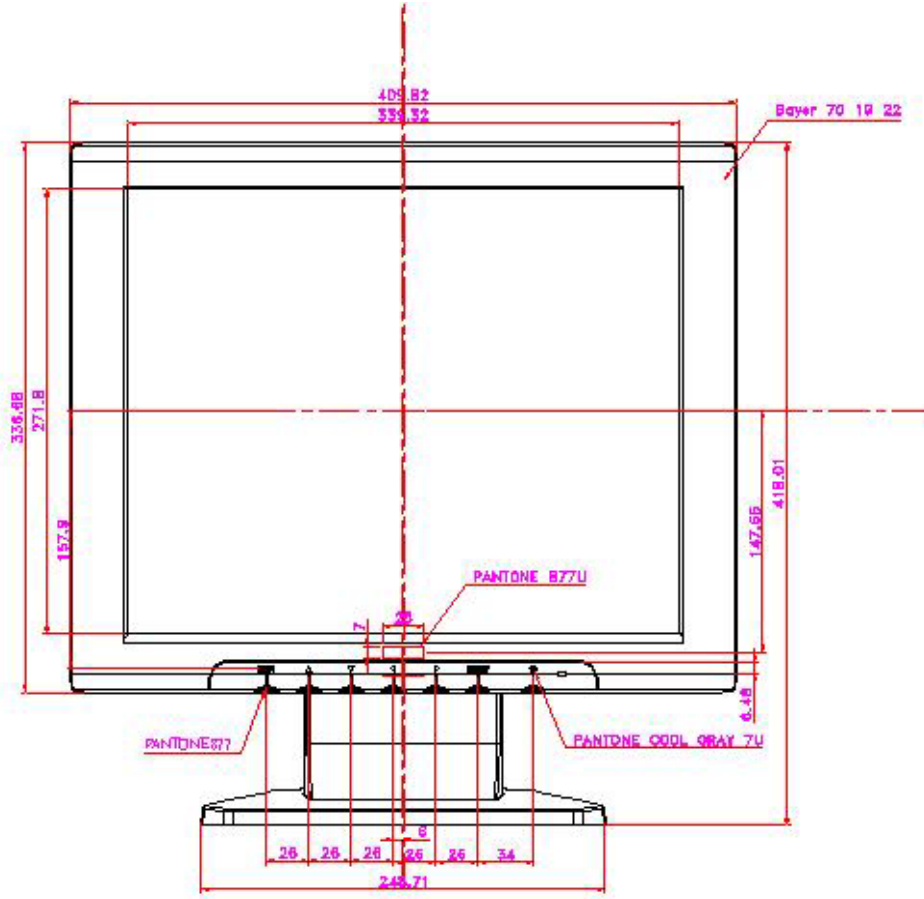

Rear Side

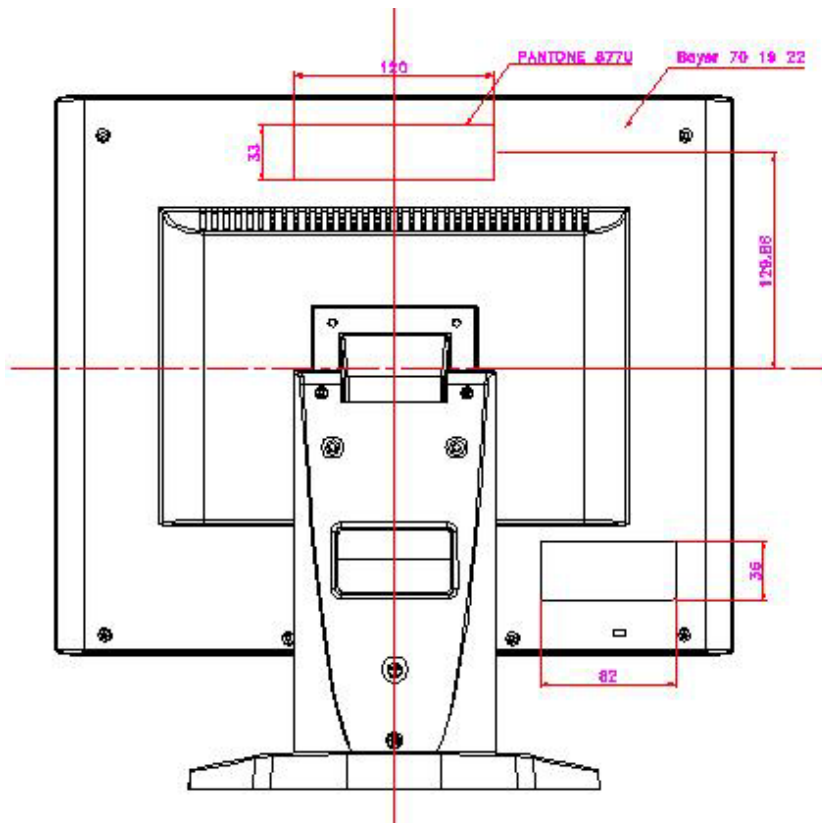

1. DIMENSIONS~2 unit : mm

Base Unit

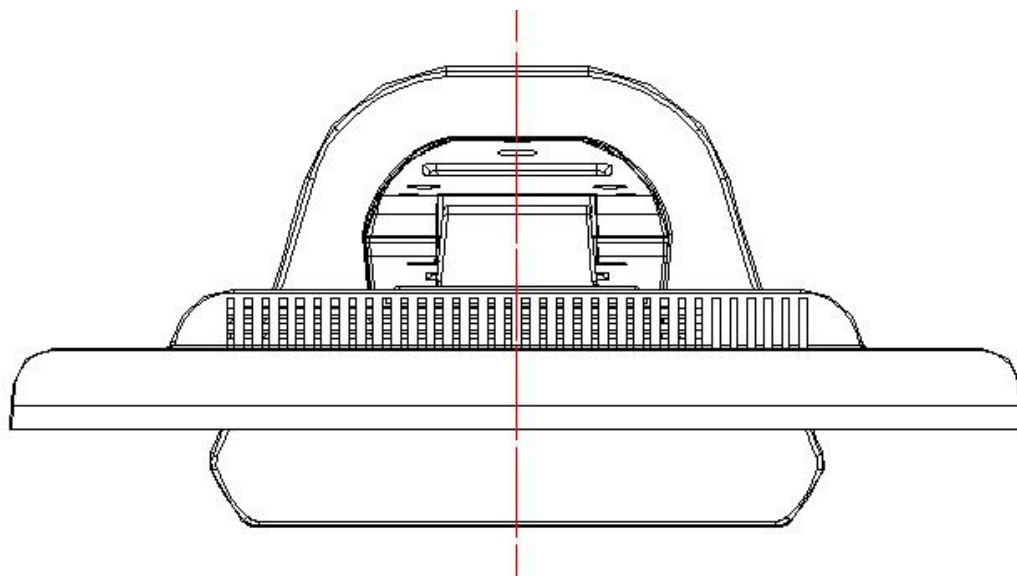

Side View

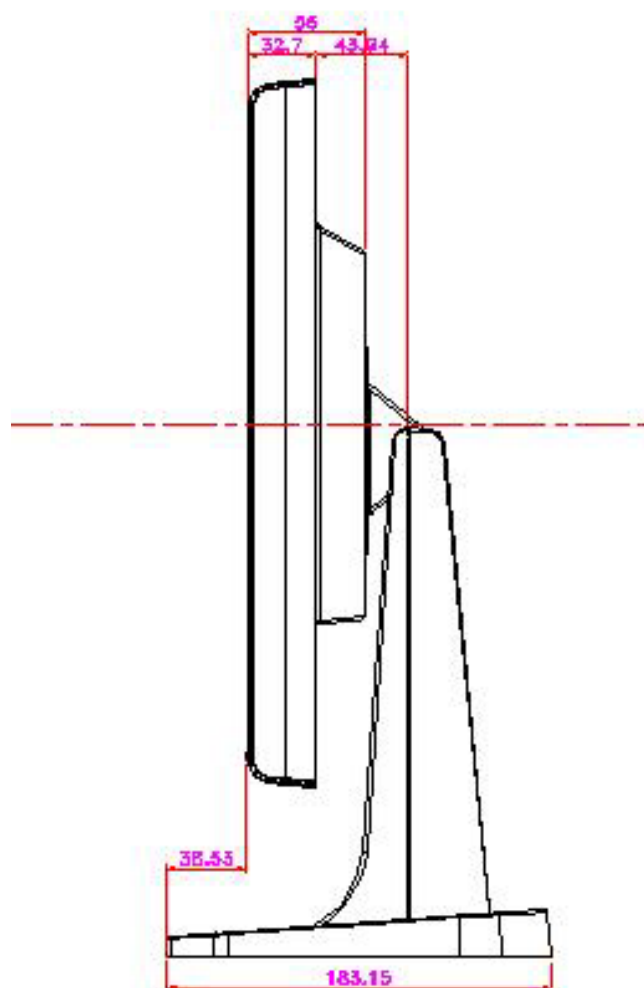

2. GENERAL INFORMATION

1. OUTLINE

This monitor is 17" multi-scan color LCD display with the following features.

OSD (on screen display) control allows easy user adjustment.

Power saving function, which helps saving energy , is also one of the highlights of this model.

2. FEATURES

2.1 Power Saving

Built in Power Saving function based on VESA-DMPS standard. Power energy shall be saved by controlling the circuit in accordance with power saving signal from computer.

2.2 OSD (on screen display) function

OSD (5 Languages) function is excellent and new man-machine interface.

Anyone is able to set up the picture as he like through OSD menu.

2.3 Self Test function

Self Testing picture comes out by pushing special key in the case of no-connection with computer or power saving operation.

This function shows if monitor is alive or not and can be used for self aging test.

2.4 Ergonomic design

Low emission design to meet MPR II and TCO

2.5 Multi scan with digital technology

8 bit micro controller controls the circuit operation to meet with wide range signal of Fh= 30~81 kHz and Fv= 56~75 Hz. So VGA640x400, VGA640x480, SVGA800x600, XGA 1024x768, SXGA 1280x1024 mode are applicable.

2.6 Factory preset

The product has 26 memory mode in total . 17 modes are preset and 9 modes are user definable.

2.7 Fine dot pitch

LCD panel with a fine dot pitch
(Horizontal : 0.264 mm / Vertical : 0.264 mm)

2.8 Superior display performance

High contrast : 350 : 1

High brightness : 250 cd / m² (Typical)

Wide view angle : 140 / 100 degrees (H/V)

2.9 Special function

VESA DDC2B (Display Data Channel)
Compatible

3. SPECIFICATION

1. Outline

- 1.1 POWER SW, LED,UP,DN,LEFT,RIGHT,SEL and MENU key are located on the front panel.
- 1.2 Video signal connector, audio line-in receptacle and DC-IN are located on the back side of the cabinet.
- 1.3 OSD menu includes the following function.
 CONTRAST BRIGHTNESS H.POSITION
 V.POSITION COLOR-TEMPERATURE
 CLOCK PHASE LANGUAGE
 VOLUME POWER-ON-RECALL
- 1.4 CONTRAST and BRIGHTNESS can be directly controlled with UP / DN key.
- 1.5 VOLUME can be controlled with LEFT / RIGHT key.

2. MECHANICAL SPECIFICATIONS

- 2.1 Dimension Height : 418 mm (16.5")
 Width : 408 mm (16")
 Depth : 183 mm (7.2")
- 2.2 Net Weight :5.6 kg (12.4 lbs)
- 2.3 Maximum Viewable Area : Diagonal 432 mm (17")

3. PANEL SPECIFICATIONS

Part No.	AA0170E1003
Driver bit of panel	8 bit
Contrast ratio	350:1 typ,
Brightness	250 cd/ m2
Pixel pitch	0.264 mm
Response time	< 30 ms (Tr+Tf)
View angle	75/75/65/60
Color coordinate	x=0.313,y=0.329

4. CONNECTORS

- 4.1 AC inlet : CEE22 typed connector

- 4.2 Audio : Line-in receptacle

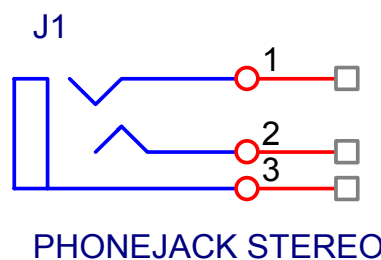

- 4.3 Video signal connector 15P Mini D-Sub connector x 1

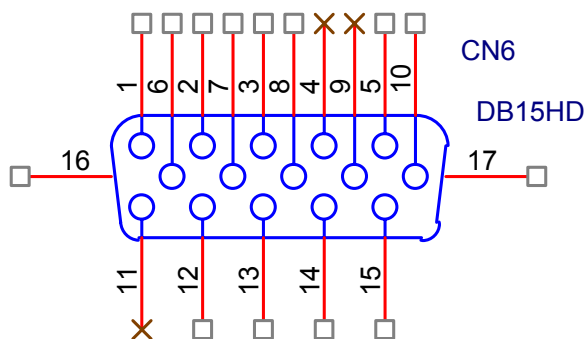

PIN	MNEMON	SIGNAL
1	RV	Red Video
2	GV	Green Video
3	BV	Blue Video
4	NC	None
5	GND	Ground(DDC return)
6	RG	Red GND
7	GG	Green GND
8	BG	Blue GND
9	+5V	+ 5V (for DDC)
10	SG	Sync GND
11	NC	None
12	SDA	DDC Data
13	HS	Horizontal Sync
14	VS	Vertical Sync
15	SCL	DDC Clock

5. ELECTRICAL SPECIFICATIONS

5.1 Standard conditions

Display area	338 x 270 mm
Video signal level	0.7 Vpp
Contrast	Max.
Brightness	Max.
Ambient	20 +/- 5 C degrees
Input voltage	AC 120,60Hz
Warming up time	> 30 minutes
Display mode	1280 x 1024

5.2 POWER

5.2.1 Power supply

Input voltage	90~240 Volts
Power frequency	50 / 60 Hz, +/-3
Input current	< 0.5 A
Inrush current	< 1 A
Power	< 50 Watts

5.2.2 Power Management

State	Power	Indicator
On	< 50Watts	Green
Standby	< 5 Watts	Amber
Off	< 5 Watts	

5.3 Acceptable timing

If your timing is within following specification, this LCD display can automatically function with a certain position.

Horizontal: Sync frequency : 30~81 kHz

Vertical : Sync frequency : 56~75Hz

5.4 Preset Timings

#	mode	Resolution	Fv Hz	Fh (KHz)
1	IBM VGA	720 x 400	70	31.46
2	VESA	640 x 480	60	31.46
3	MAC 13"	640 x 480	67	35
4	VESA	640 x 480	72	37.86
5	VESA	640 x 480	75	37.5
6	VESA	800 x 600	56	35.16
7	VESA	800 x 600	60	37.87
8	VESA	800 x 600	72	48.07
9	VESA	800 x 600	75	46.87
1	MAC 16"	832 x 624	75	49.72
1	VESA	1024 x 768	60	48.36
1	VESA	1024 x 768	70	56.48
1	VESA	1024 x 768	75	60.02
1	VESA	1152 x 864	75	67.5
1	VESA	1280 x 1024	60	63.98
1	VESA	1280 x 1024	75	79.97

5.5 Signal level and input impedance

5.5.1 Video Signal level

This LCD display is adjusted at the factory using 0,7 Vp-p Video signal.

5.5.2 Sync Signal level

H/V Separate : TTL level

5.5.3 Input impedance

Video input : 75 ohms

Sync input : > 1 k ohms

5.6 Display Area

Display area : 338 x 270 mm

5.7 General performance

5.7.1 Maximum pixel clock

135 MHz

5.7.2 Maximum luminance

Value	250 cd / m ² at center of the display area ,Specified by 6500K + 8 MPCD
Conditions	Display image : Full white Brightness : Maximum Contrast : Maximum

5.7.3 Brightness variation

Value	75 % Variation = C / A x 100
Conditions	Display image: Full white Brightness : Maximum Contrast : Maximum A: Luminance at center position C: Luminance at position of lowest brightness

5.7.4 Contrast ratio (CR)

Value	CR= B / A
Conditions	Contrast : Maximum B: Full white pattern Brightness : min A: Full black pattern Brightness : max

6. ENVIRONMENTS

	Operation	Storage and Shipment
Temperature	0 ~ 40 C	-20 ~ +60 C
Humidity	5 ~ 90 %	5 ~ 90 % *
Altitude	3000m	12000m

* Non-condensation

7. REGULATORY STANDARDS

7.1 Safety standards

This monitor applies to various safety & EMI standards May refer to the logo label

7.2 EMC standards

FCC part 15, subpart B , class-B
CE marking

8. OTHERS

TUV (Rheinland)
ISO13406-II pixel fault class 2
TCO99

9. POWER CORD

Northern Hemisphere Version : UL / CSA approved power cord.
European : VDE approved power cord.

10. SIGNAL CABLE

Signal cable with Mini D-Sub 15P connectors at both ends.
Length : 1.5 meter.

11. RELIABILITY

11.1 MTBF for completed unit without LCD
> 30,000 hours (demonstrated MTBF)

11.2 MTBF for LCD

The brightness is still more than 50% of the original brightness after 25,000 hours (min.)

4. THEORY OF OPERATION

This section describes the function of the LCD monitor per functional block.

L7EA monitor includes MB board, audio board (option), inverter board, adapter and button board.

4.1 MB BOARD

The MB board is a four-layer, single-layered design with ground and internal planes provided. DC power from the power adapter enters the board through DC jack. Other connectors on the board are for inverter, audio and button board. The VGA cable is a signal cable that contains video signal, sync signal and DDC signal from PC VGA adapter.

This system board consists of 4 functional areas: flat panel controller, flash ROM, power regulator and LVDS transmitter.

4.1.1 Flat panel controller..... gm2120 (U8)

The heart of the system board is Genesis gm2120. The gm2120 is a graphics processing IC for LCD monitor. It provides all key IC functions required for LCD panel. On-chip functions include a high-speed triple-ADC, PLL, high sampling engine, OSD controller and on-chip microcontroller.

a) Clock Generation :

Crystal Input Clock (TCLK and XTAL). This is the input pair to an internal crystal oscillator and corresponding logic. A 14.318 MHz crystal is recommended.

b) Hardware Reset (Pin 5)

Hardware Reset signal is generated by MAX6326 (U10). It asserts a reset signal at least 100 ms.

c) Analog to Digital Converter

The gm2120 chip has three ADC's (analog-to-digital converters), one for each color (red, green and blue). The analog RGB signals are connected to gm2120 as described below

Pin Name	Pin Number
Red +	171
Red -	170
Green +	167
Green -	166
Blue +	163
Blue -	162

d) OSD :

The gm2120 has a fully programmable, high-quality OSD controller. The on-chip static RAM (4096 words by 24 bits) stores the cell map and the cell definitions.

e) On-Chip Microcontroller (OCM)

The gm2120 on-chip microcontroller (OCM) serves as the system microcontroller. That is, it programs the gm2120 and manages other devices in the system such as the keypad, the backlight, LED, audio and non-volatile RAM using general purpose input/output (GPIO) pins.

Pin Number	Pin Name	Pin Usage
40	GPIO0 / PWM0	Backlight control
41	GPIO1 / PWM1	Volume control
42	GPIO2 / PWM2	Key-Left
43	GPIO3 / TIMER	Key-Up
44	GPIO4 / UART_DI	Debug Purpose
45	GPIO5 / UART_DO	Debug Purpose
46	GPIO6	Key-Right
47	GPIO7	Key-Down
39	GPIO8 / IROINn	LED-Orange
48	GPIO9	Key-Sel
49	GPIO10	Key-Menu
50	GPIO11	No use
51	GPIO12	NV- RAM (U4) SDA
52	GPIO13	NV- RAM (U4) SCL
205	GPIO16 / HFSn	NV- RAM (U11) SCL
1	GPIO17	No use
208	GPIO18	No use
207	GPIO19	Key-Power, on / off control
206	GPIO20	Mute , audio disable
4	GPIO21 / IROn	LED-Green
204	GPIO22 / HCLK	NV- RAM (U11) SDA

f) Panel Power Sequencing (PPWR, PBIAS) (Pin 113~114)

20 has two dedicated outputs PPWR and PBIAS (Pin113 and Pin114) to control LCD power sequencing once data and control signals are stable.

g) Parallel ROM Interface Port (Pin 8~25, Pin28~35)

The gm2120 has parallel ROM interface port , pin8~25 for address bus, pin28~35 for data bus.

h) Panel interface (Pin 55~66, Pin69~80, Pin83~87, Pin90~96.Pin99~110)

The gm2120 driver interface is highly programmable. It supports dual bus / dual port for SXGA drivers.

4.1.2 LVDS Transmitter DS90C383 (U1,U2)

The DS90C383 transmitter converts 28 bits of TTL data into four LVDS (Low Voltage Differential Signaling) data streams. A phase-locked transmit clock is transmitted in parallel with the data streams over a fifth LVDS link. At a transmit clock frequency of 85 MHz, 24 bits of RGB data and 3 bits of LCD timing and control data (FPLINE, FPFRAME, DRDY) are transmitted at rate of 595 Mbps per LVDS data channel. U1 AS the ODD pixel transmitter , U2 as the EVEN pixel transmitter.

4.1.3 Power Regulator AIC1563 (U12),LT1117 (U5, U6)

The AIC1563 is a monolithic control IC containing the primary functions required for DC to DC converters. The device consists of an internal temperature compensated reference, comparator, controlled duty cycle oscillator with an active current sense circuit. Desired output voltage are determined by the equation $V_{out} = 1.25 (1 + R_{104} / R_{103})$, In this case, the output voltage are 5 Volts.

The AIC1117 is a low dropout positive adjustable regulator with mininum of 1A output current capability. So it is well suited for 3.3 V and 2.5 V Rregulator.

U6 as a 2.5 V regulator , Desired output voltage are determined by the equation $V_{out}=5 \times (R_{53} / R_{53}+R_{56})= 2.5$

U5 as a 3.3 V regulator , Desired output voltage are determined by the equation $V_{out}=5 \times (R_{30} / R_{30}+R_{36})= 3.3$

4.2 Audio Board AN7522 (U1)

The AN7522 is a 2 channel audio power amplifier capable of delivering 2W of continuous average power to an 8 ohms with less than 0.5% (THD) from a 12 V power supply.

An7522 can directly drive 8 ohms speaker , does not require output coupling capacitor, bootstrap capacitor ,or snubber network. Audio line-in are feed into pin 6,8 of the AN7522. The output power is controlled by the DC voltage of pin 8 from gm2120 GPIO port.

4.3 Inverter Board

This is a specific inverter for L7E monitor backlight which converters 12 Vdc to drive four cold cathod fluorecence tubes. Electrical specification described as below.

INPUT	Rated Input Voltage	12Vdc
	Maximum Input Voltage	11.4~12.6 Vdc
	Input Current	< 2A
	Off state Input Power	< 0.1 W
	On / Off Voltage	2~3.3 for On, 0~1 for Off
OUTPUT	Rated Output Strike-on Voltage	1310 Vrms
	Rated Output Voltage	710 Vrms at 6 mA
	Rated Output Frequency	45~60KHz
	Rate Output Current per tube	6 mA

4.4 Adapter

This is a general purpose AC / DC adapter which converter 90~240 Vac to a stabilized DC voltage 12 V with rated output current of 4.16A . Electrical specification described as below.

INPUT	Rated Input Voltage	90~240 Vac , 50/60 Hz
	Operation Input Voltage	90~260 Vac, 47~63 Hz
	Input Current	< 1.5A
	Inrush Current (Cold Start)	< 100A @ 120Vac
	Standby Input Power	< 1.5 W at 120Vac
OUTPUT	Rated Output Voltage	12 Vdc
	Output Voltage Regulation	+ 10 / -5 %
	Output Ripple and Noise	< 600 mVp-p
	Rate Output Current	< 4.16A
	Turn-on Delay	< 1 Second

5. DISASSEMBLY INSTRUCTIONS

1. Stand& rear cover removal

- 1) remove four large screw "1" from the rear cover
- 2) remove the rear cover
- 3) remove four screw "2"
- 4) remove the stand

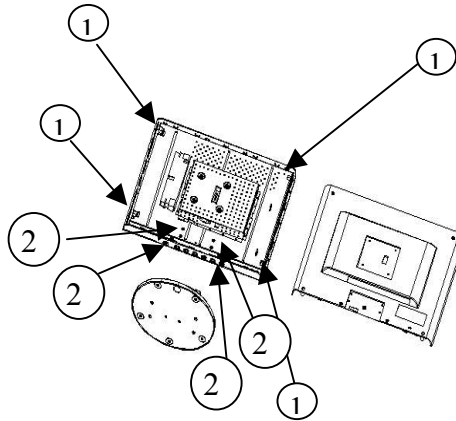

2. ESD cover removal

- 1) remove four screw "3"
- 2) remove the ESD cover

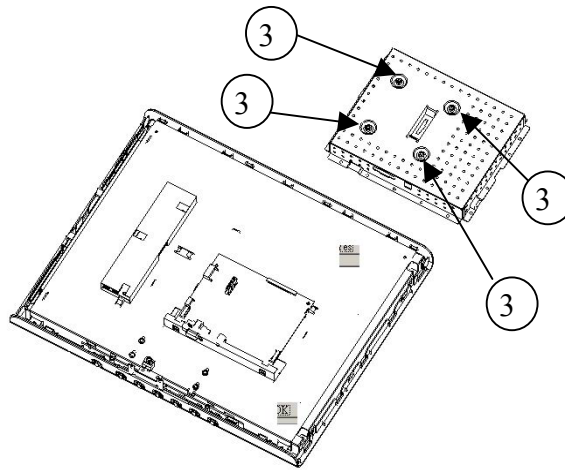

TYPE : DRAFT NAME : NONE SIZE : C

3. MB board removal

- 1) remove four screw "4"
- 2) remove the MB board

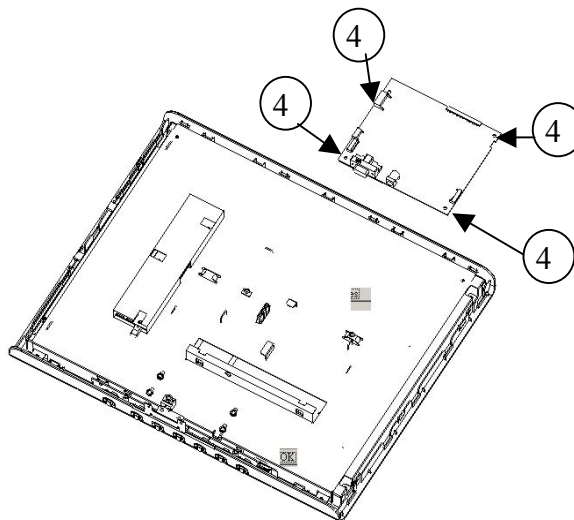

TYPE : DRAFT NAME : NONE SIZE : C

4. Inverter board removal

- 1) remove two screw "5"
- 2) remove the Inverter board

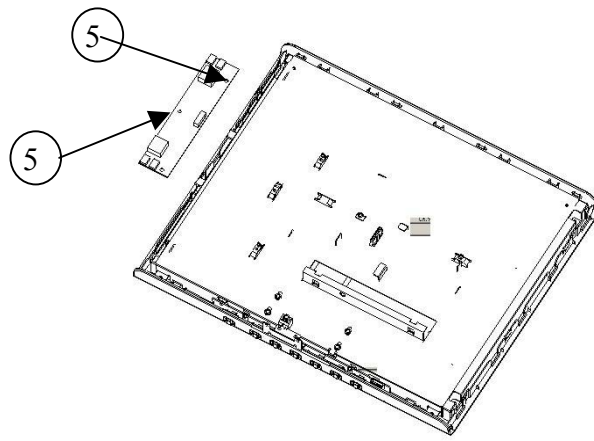

TYPE : DRAFT NAME : NONE SIZE : C

6. Panel module removal

- 1) remove four screw "6"
- 2) remove the Panel module

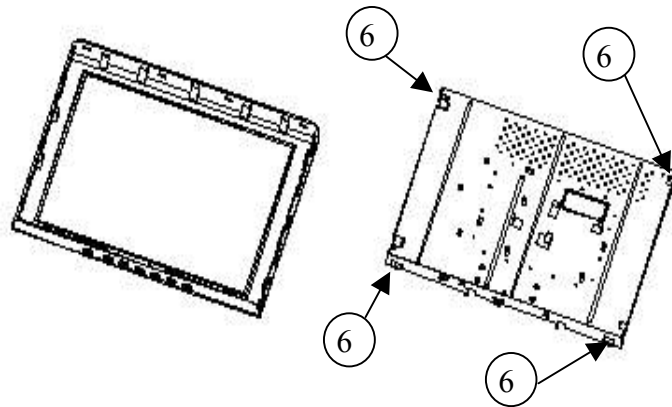

7. Panel removal

- 1) remove four screw "7"
- 2) remove the Panel

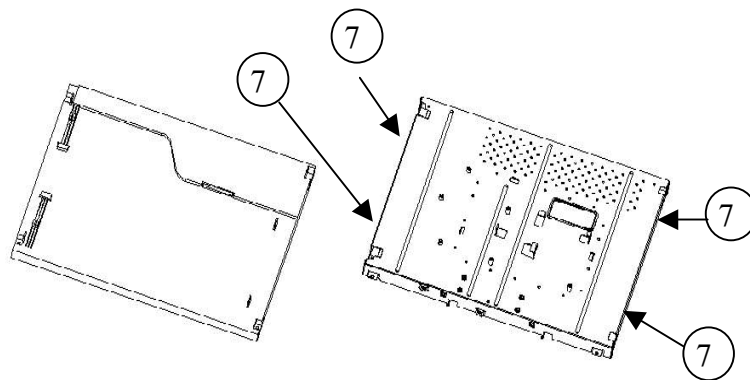

6. CONTROL LOCATION

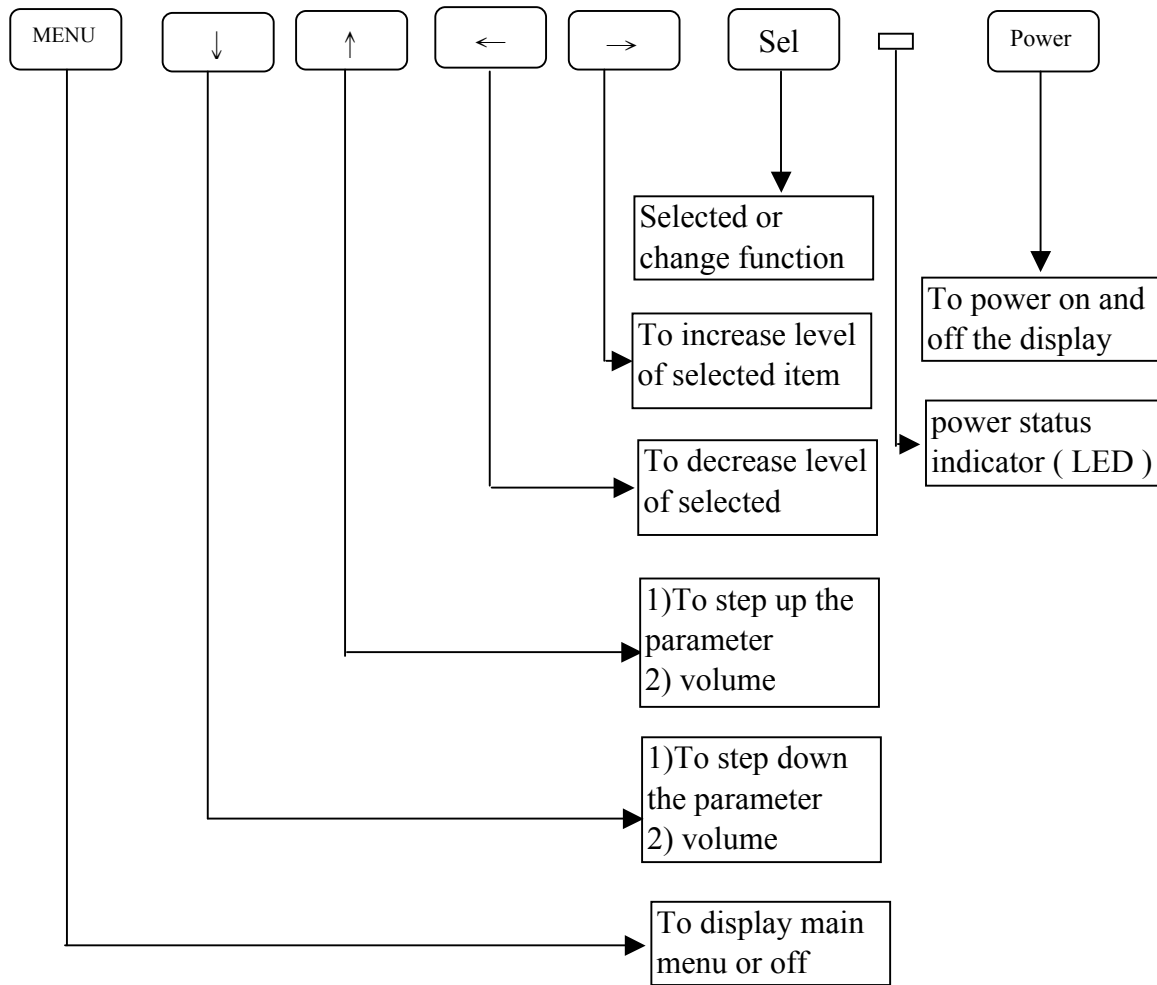

Examples of on-screen operation

A. Brightness / Contrast Adjustment

Brightness. Press the \triangle and ∇ buttons to adjust the brightness of the screen.

Maximize the life of your display by using the lowest brightness setting you are comfortable with.

You may need to readjust brightness after the display is warmed up.

Contrast. Press the $<|$ and $|>$ buttons to adjust the contrast of the screen.

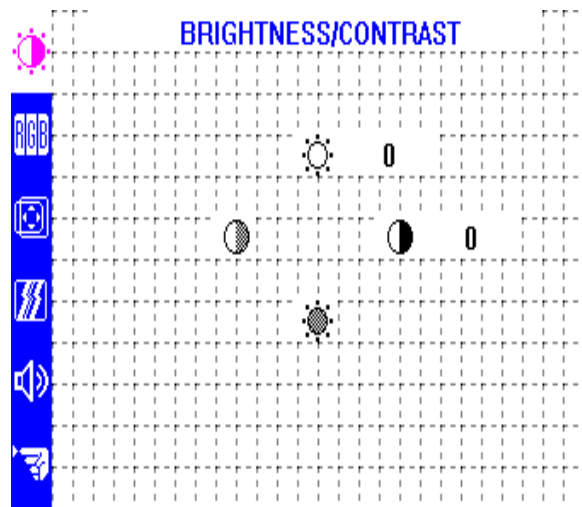

Vertical position. Press the \triangle and ∇ buttons to move image up and down.

Horizontal position. Press the $\langle I$ and $I \rangle$ button to move image left and right.

The Auto function configures the vertical and horizontal position for you.

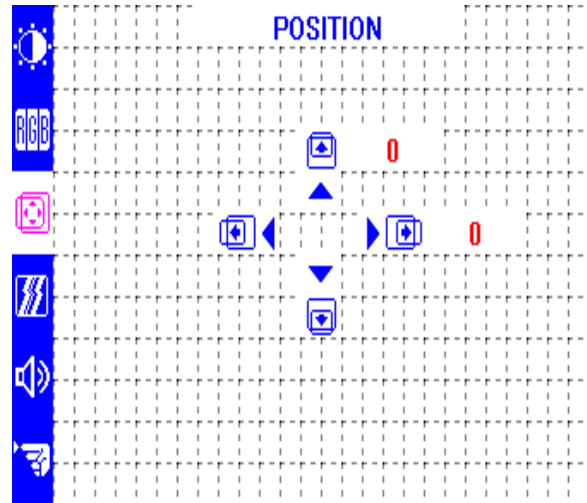

Language. Press the $\langle I$ and $I \rangle$ buttons to change the OSD language display setting.

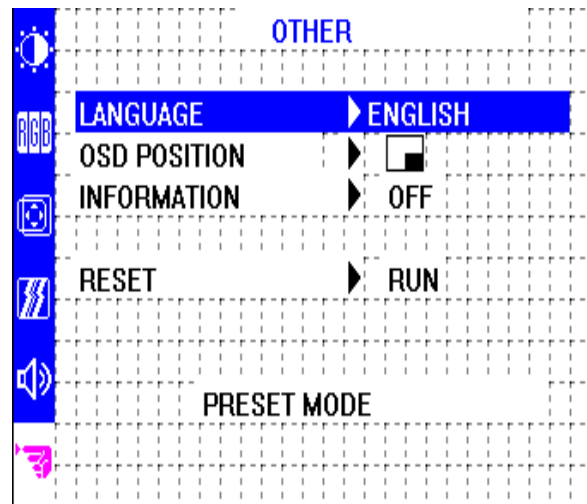

7. NECESSARY EQUIPMENT LIST

- | | Item |
|---|---|
| 1 | Personal Computer with Windows 98 or above version |
| 2 | Luminance Meter Minolta CA 110 |
| 3 | Video Gnerator : Chroma 2000,2135,2250 or equivalent |
| 4 | Colour Analyzer : Minolta , Chroma or equivalent |
| 5 | Watt / Power Meter |
| 6 | 10 Times Magnifier |

8. L7EA (AL708) BLOCK DIAGRAM~1 ~Video

LM7S Block Diagram

1.VIDEO

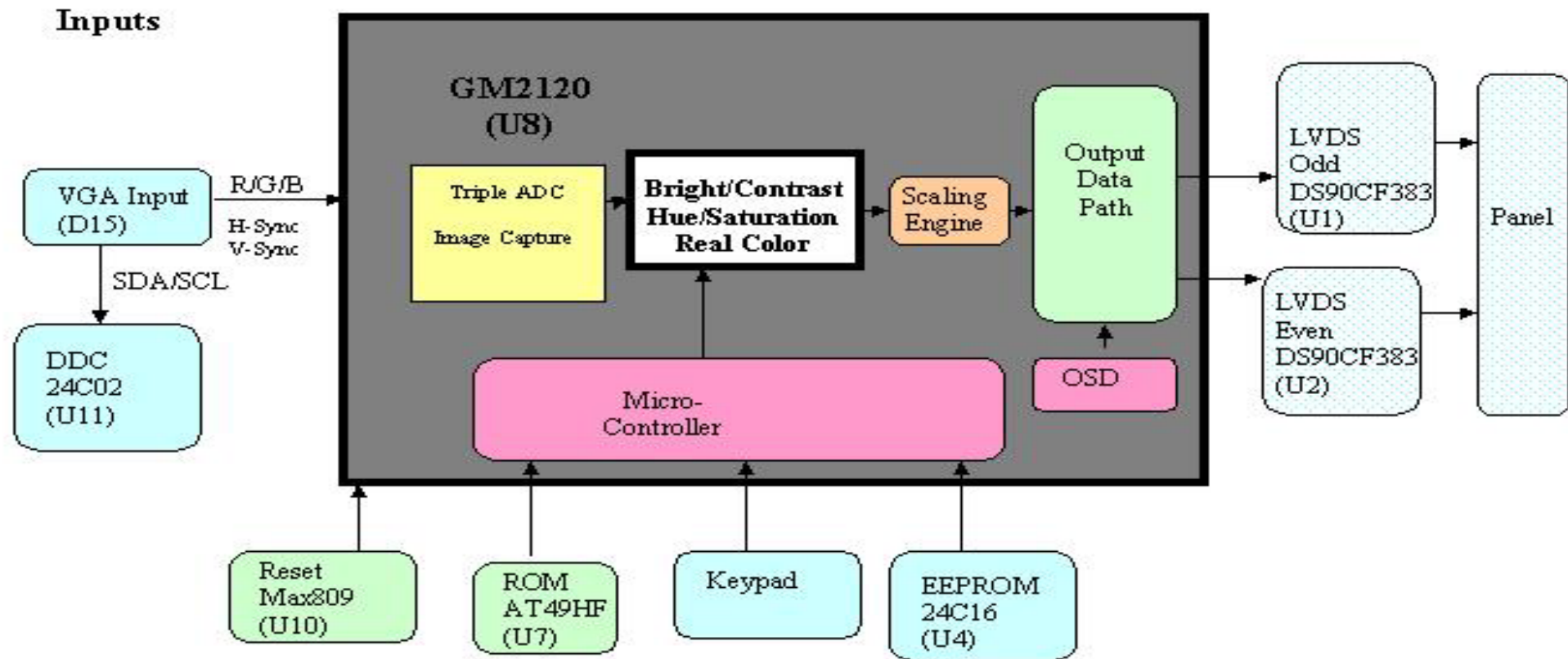

8. L7EA (AL708) BLOCK DIAGRAM~2 ~Audio

LM7S Block Diagram

2.AUDIO

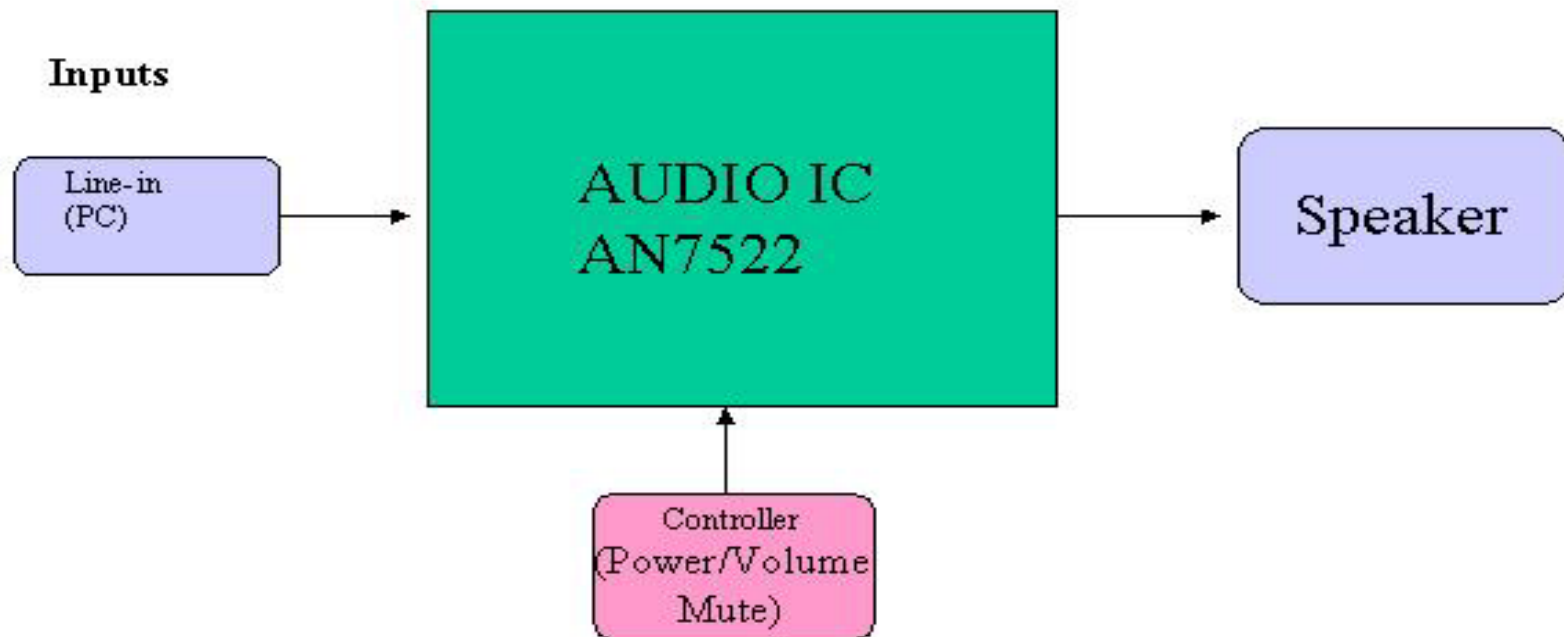

8. L7EA (AL708) BLOCK DIAGRAM-3 ~Power

LM7S Block Diagram

3.POWER

Inputs

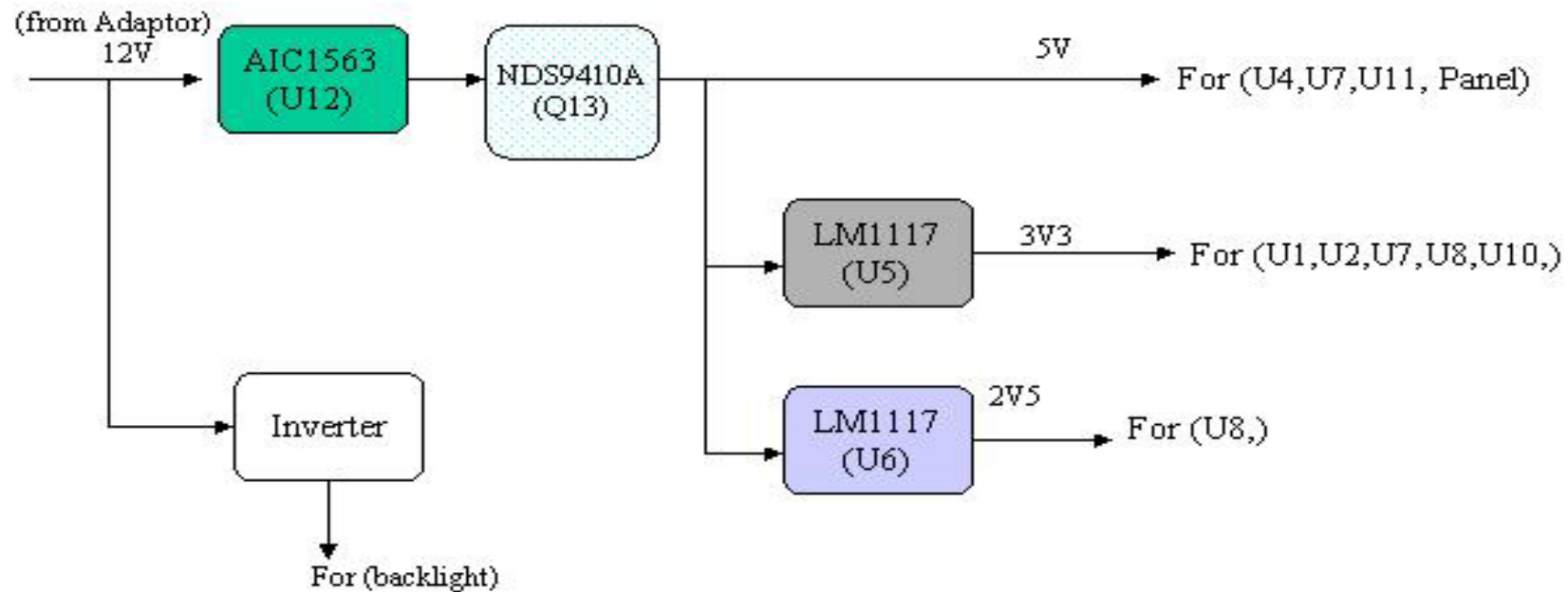

9. CONDUCTOR VIEW 1~3

MB board

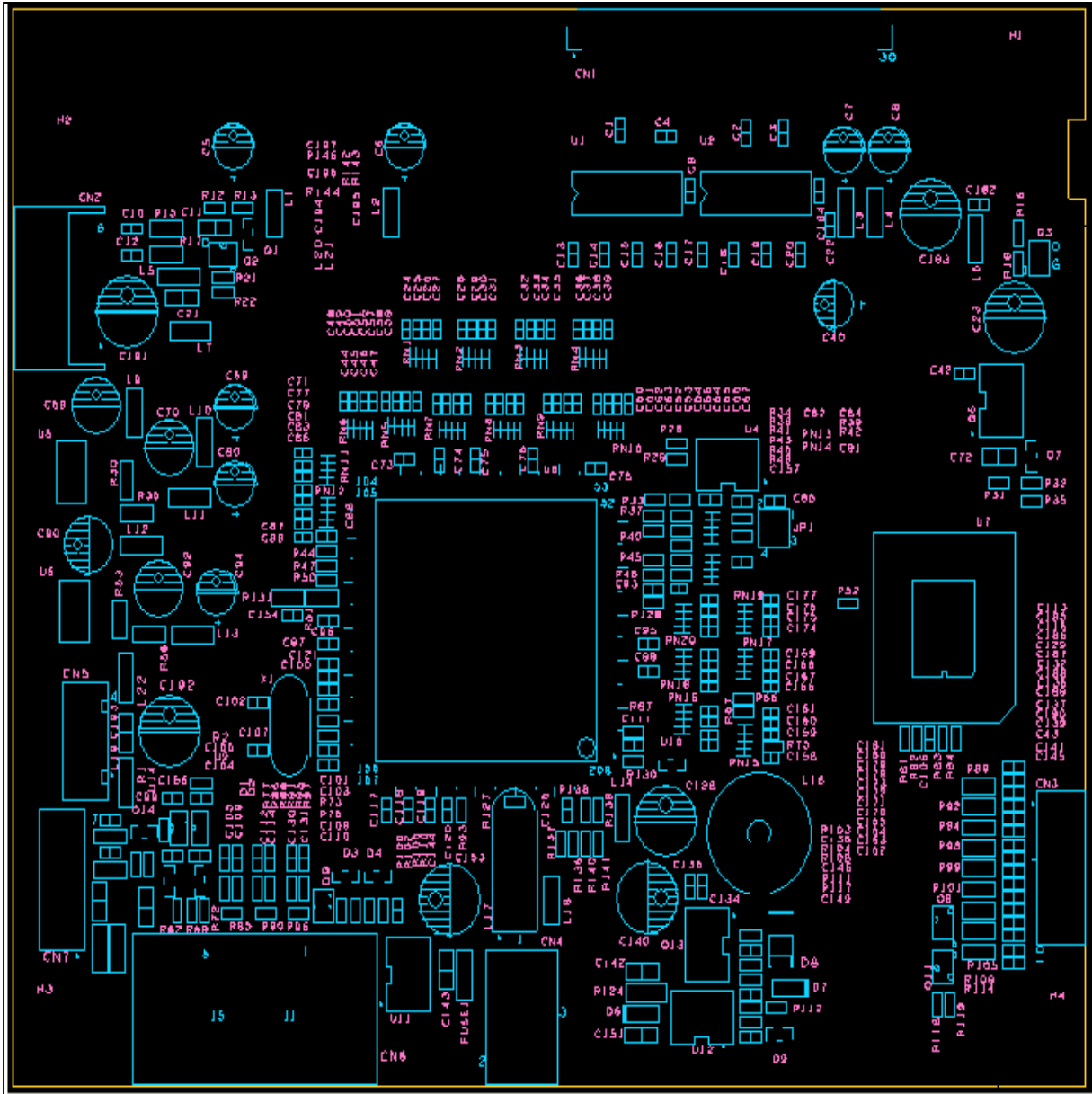

Audio board

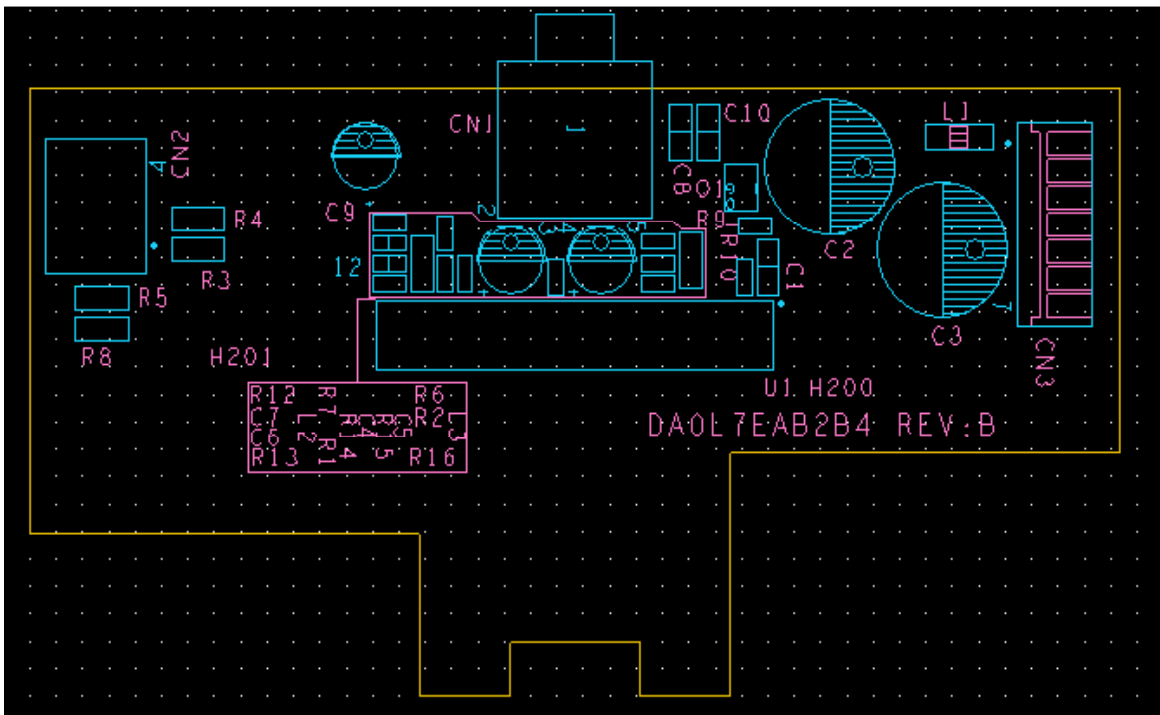

Button board



10. SCHEMATIC DIAGRAM~1

Input connector

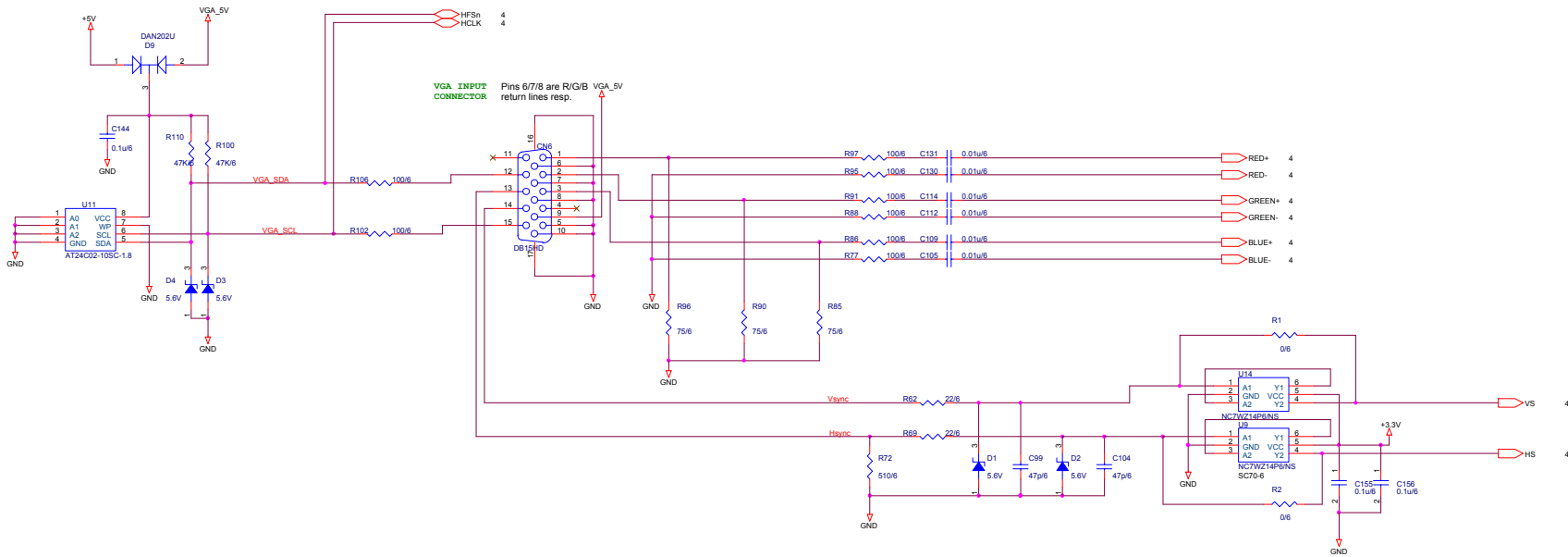

Confidential

		PROJECT : L7E	
		Quanta Computer Inc.	
INPUT CONNECTOR			
Size	Document Number	DISPLAY	Rev A
Date	Friday, May 24, 2002	Sheet 3 of 7	

10. SCHEMATIC DIAGRAM~4

LVDS-IF

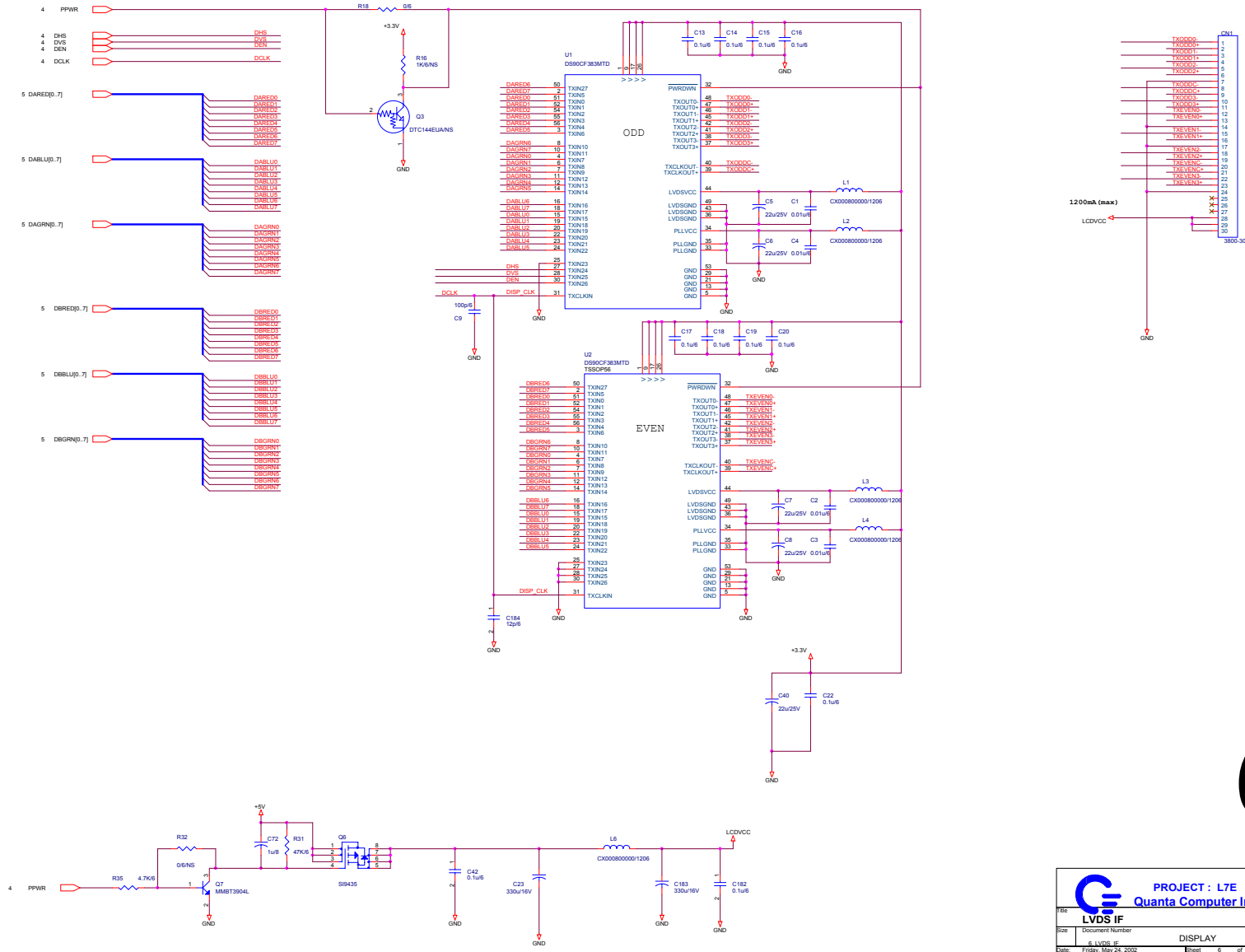

Confidential

 PROJECT : L7E Quanta Computer Inc.		
REV	Document Number	REV A
REV	LVDS IF	DISPLAY
DATE	Friday, May 24, 2002	Page 6 of 7

10. SCHEMATIC DIAGRAM~5

Power

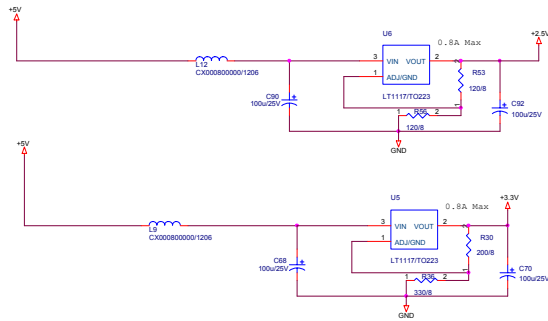
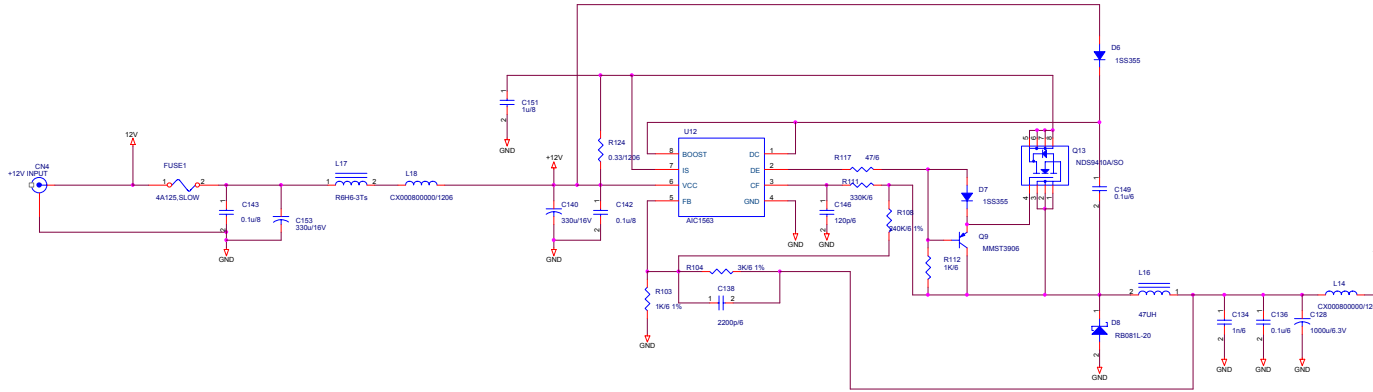

		PROJECT : L7E	
		Quanta Computer Inc.	
POWER			
File	Document Number	Rev	A
L7E Power		DISPLAY	
Date: Fri, May 24, 2002	Sheet	7	of 7

Confidential

10. SCHEMATIC DIAGRAM~6

Button board

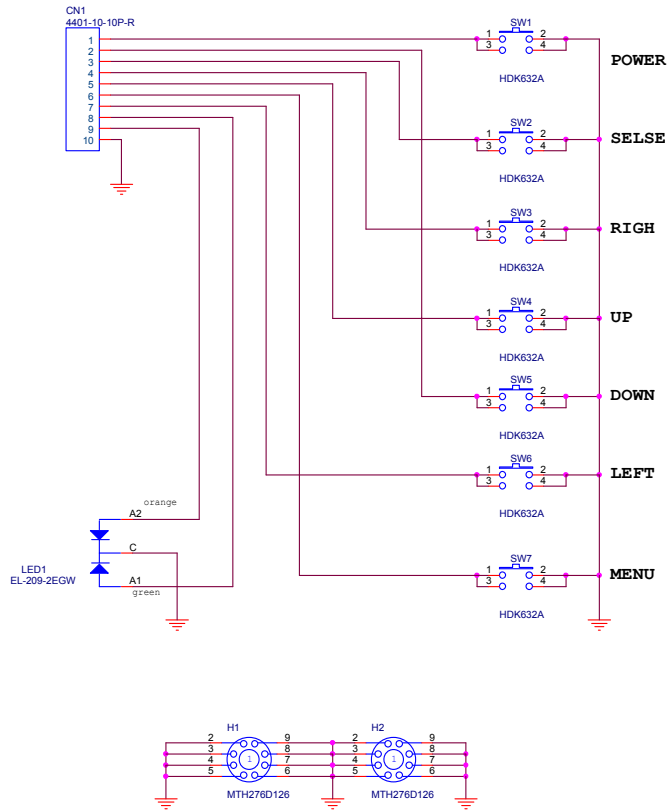



Confidential

 PROJECT : L7E Quanta Computer Inc.	
Title: L7E	
Size: Document Number	Rev: A
Date: Friday, May 24, 2002 Sheet 2 of 2	

10. SCHEMATIC DIAGRAM~7

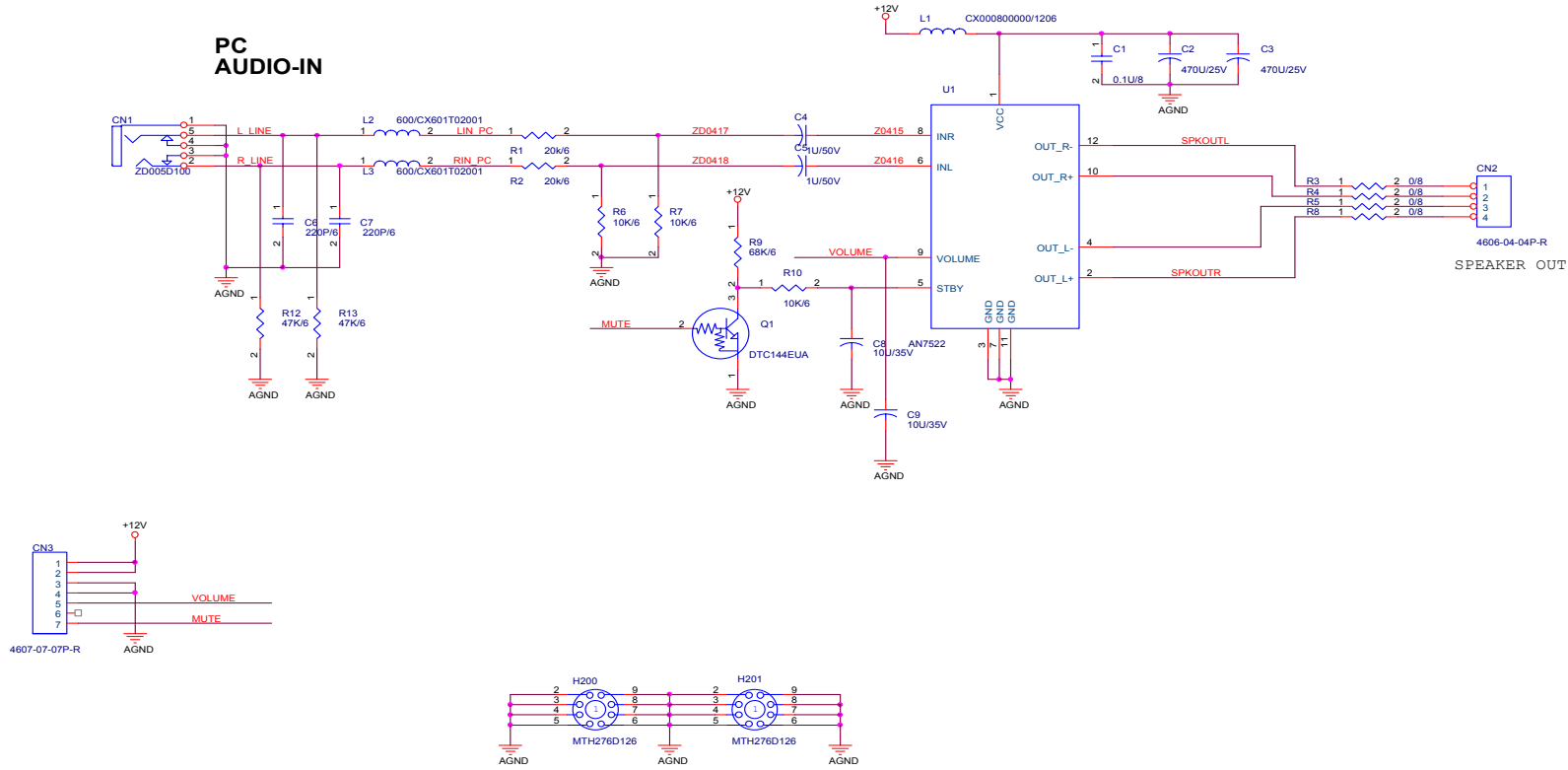
Audio



 PROJECT : L7E Quanta Computer Inc.	
Title	CONTENT
Size	Document Number
Date	SCHEMATIC
Friday, May 24, 2002	Sheet 2 of 2

Confidential

11. TROUBLE SHOOTING HINTS

1. No Power

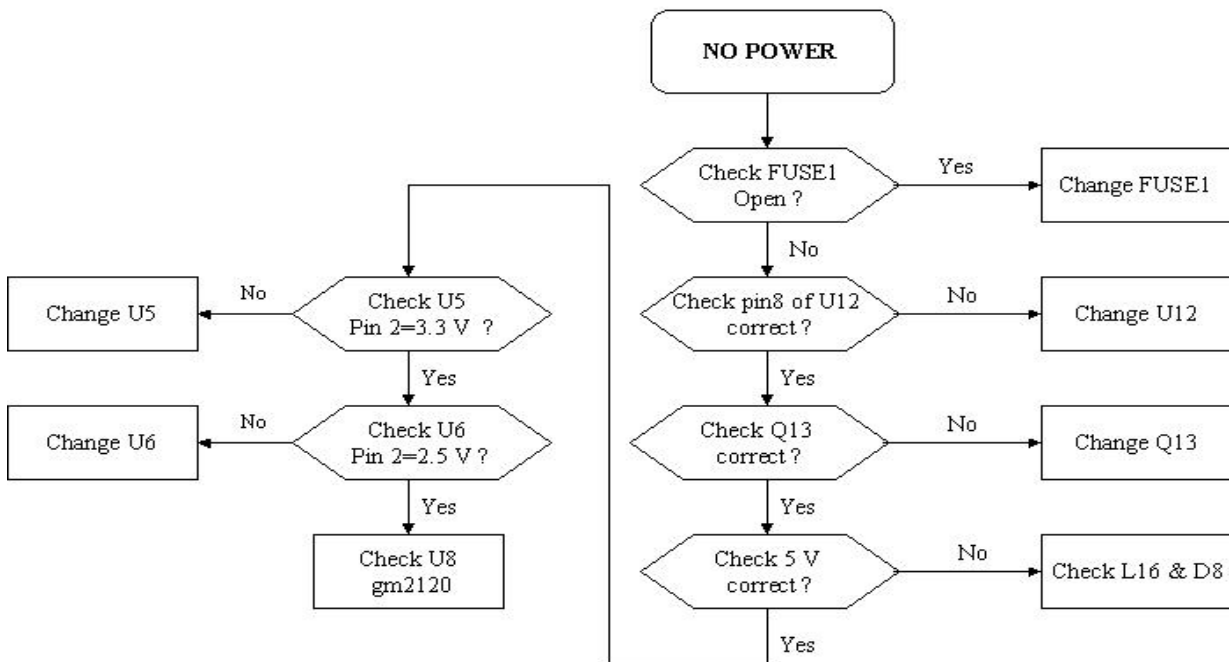

2. No Characters , Missing one Color

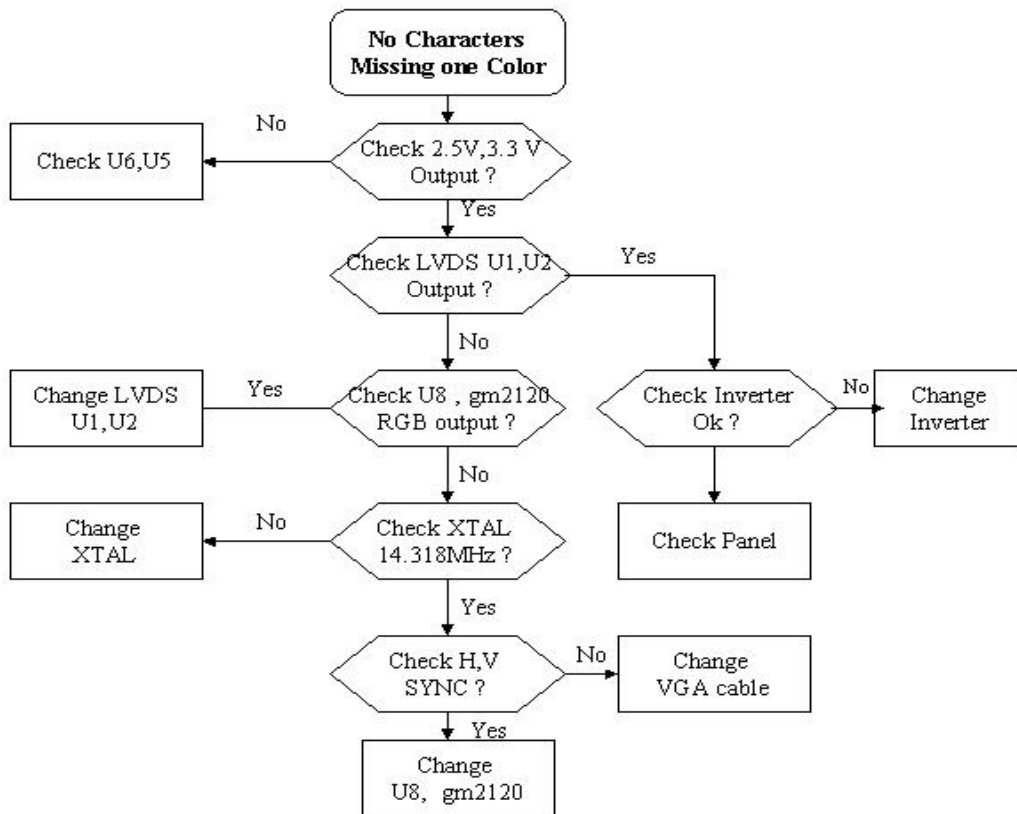

3. No Audio

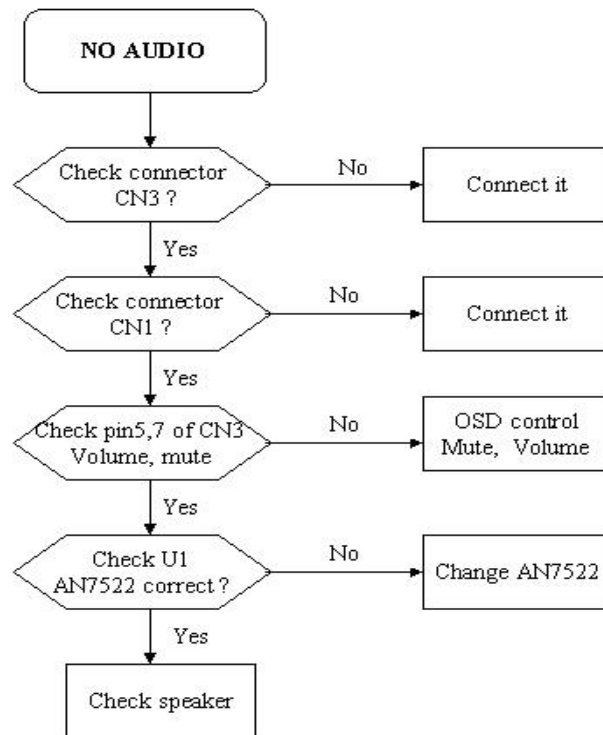

12. REPLACEMENT PARTS LIST~1

Audio board

Symbol	PARTS NO.	Description
CN1	DFHD03MR065	CONN DIP HEADER 3P 1R MR(P1.5,H4.1)
CN2	DFHD04MR124	CONN DIP HEADER 4P 1R MR(P2.0,H4.1)
CN3	DFHD07MR047	CONN DIP HEADER 7P 1R MR(P2.0,H4.1)
L1	CX0P121R000	EMI FILTER CHIP HI1206P121R-00(120 6A)
L2,L3	CX601T02001	EMI FILTER CHIP N2012Z601T02(0.2A,600
R12,R13	CS34703J901	RES CHIP 47K 1/10W +-5%(0603)
R6,R7,R10	CS31003J908	RES CHIP 10K 1/10W +-5%(0603)
R9	CS36803J901	RESISTOR CHIP 68K 1/10W +-5%(0603)
R1,R2	CS11003F902	RESISTOR CHIP 100 1/10W +-1%(0603)
R3,R4,R5,R8	CS00004JA07	RESISTOR CHIP 0 1/8W +-5%(0805)
C4,C5	CC51006MZ03	CAP ELEC CHIP 1U 50V(+20%,105C,4*5.4)
C1	CH41004MA14	CAPACITOR CHIP 0.1u 25V(+20%,X7R,0805)
C6,C7	CH12206J901	CAPACITOR CHIP 220P 50V(+5%,NPO,0603)
C8,C9	CC61006MD32	CAP ELEC 10U 50V(+20%,105C,5*7,LESR)
C2,C3	CC74704MD88	CAP ELEC 470U 25V+-20%,105C,10*12.5,LESR
Q1	BA144EUAZ04	TRANSISTOR SMD DTC144EUA(50V,30MA)
U1	AL007522D03	IC(12P) AN7522(DIP)
	DALM7QAB2E0	PCB(AUDIO)LM7Q AUB(2L,70*40,REVE)

13. REPLACEMENT PARTS LIST~2

Button board

Symbol	PARTS NO.	Description
CN1	DFHD10MR197	CONN DIP HEADER 10P 1R MR(P1.5,H4.1)
LED1	BEYG0013DA3	LED(DIP) YELLOW/GREEN(L-3WYGW)
SW1,SW2,SW3,SW4,SW5	DHP0002B108	SWITCH PUSH BUTTON(PT-002-B1,50mA,12V
SW6,SW7		
	DALM7QTB2B9	PCB(BUTTON) LM7Q TB(2L,222*27.5,REVB)

13. REPLACEMENT PARTS LIST~3

Audio in

Symbol	PARTS NO.	Description
CN1	DFHD03MR065	CONN DIP HEADER 3P 1R MR(P1.5,H4.1)
J1	DFTJ05FR355	CONN DIP PHONE JACK 5P FR(H10)
	DALM7AB12A3	PCB(EAR) LM7Q AUB(2L,14*36,REVA)

13. REPLACEMENT PARTS LIST~4

MB board

Reference	Material	Description
CN4	DFPJ03MR140	CONN POWER JACK 3P MR
FUSE1	DK400WFU001	FUSE SMD 4A/32V,FAST(UL/CSA,3216)
U7	DGP320001Z0	IC SOCKET,SMD PLCC 32P(LOW PROFILE,SMD)
CN1	DFHD30MR127	CONN SMD HEADER 30P 1R MR(P1.25 H1.9)
CN3	DFHD10MR197	CONN DIP HEADER 10P 1R MR(P1.5,H4.1)
CN2	DFHD06MR093	CONN DIP HEADER 6P 1R MR(P2.5,H4.1)
CN6	DFDS15FR513	CONNECTOR D-SUB 15P 3R FR(P1.15,H12.55)
CN7	DFHD07MR047	CONN DIP HEADER 7P 1R MR(P2.0,H4.1)
L16	DC04725K002	CHOKE COIL 47UH(2.5A,+10%,T07473)
L17	CWK5BR6H019	FERRITE CORE K5B R6H 6*10*0.85-2TS-B
L1,L2,L3,L4,L5	CX0P121R000	EMI FILTER CHIP HI1206P121R-00(120 6A)
L6,L7,L8,L9,L10		
L11,L12,L13,L14,L18		
L20,L21		
R12,R31,R100,R110,R142	CS34703J901	RES CHIP 47K 1/10W +5%(0603)
R13,R28,R29,R33,R34	CS31003J908	RES CHIP 10K 1/10W +5%(0603)
R52,R66,R67,R75,R81		
R83,R127,R140,R141,R143		
R35	CS24703J900	RES CHIP 4.7K 1/10W +5%(0603)
R39,R42	CS22003J909	RES CHIP 2K 1/10W +5%(0603)
R93,R112,R118,R119	CS21003J906	RES CHIP 1K 1/10W +5%(0603)
R103	CS21003F904	RESISTOR CHIP 1K,1/10W,+1%(0603)
R62,R69,R77,R86,R88	CS11003J904	RESISTOR CHIP 100 1/10W +5%(0603)
R91,R95,R97,R102,R106		
R37,R38,R40,R41,R43	CS02203J902	RES CHIP 22 1/10W +5%(0603)
R44,R45,R46,R47,R48		
R49,R50,R87,R128,R138		
R139		
R15,R17,R144,R146	CX0600YS002	EMI FILTER PBY201209T-600Y-S(4A,60)
R18,R21,R73,R76,R82	CS00003J900	RESISTOR CHIP 0 1/10W+5%(0603)
R84,R136,R137		
R53,R56	CS11204JA09	RES CHIP 120 1/8W,+5%(0805)
R85,R90,R96	CS07503J907	RES CHIP 75 1/10W,+5%(0603)
R104	CS23003F900	RES CHIP 3K 1/10W,+1%(0603)
R108	CS42403F905	RESISTOR CHIP 240K 1/10W,+1%(0603)
R117	CS04703J906	RES CHIP 47 1/10W,+5%(0603)
R111	CS43303J906	RES CHIP 330K 1/10W,+5%(0603)
R72	CS15103J909	RESISTOR CHIP 510 1/10W,+5%(0603)
R51,R89,R92,R94,R98	CS02204JA00	RESISTOR CHIP 22 1/8W+5%(0805)
R99,R101,R105,R109,R114		

R131		
R36	CS13304FA06	RESISTOR CHIP 330 1/8W+-1%(0805)
R30	CS12004FA02	RESISTOR CHIP 200 1/8W,+ -1%(0805)
R124	CS00006J205	RESISTOR CHIP 0 1/4W+-5%(3216)
RN1,RN2,RN3,RN4,RN5	CJ022084N10	RES ARRAY CHIP 22,1/16W(+ -5%,8P4R)R-PIN
RN6,RN7,RN8,RN9,RN10		
RN11,RN12,RN15,RN16,RN17		
RN18,RN19,RN20		
RN13,RN14	CJ310084N15	RES ARRAY CHIP 10K,1/16W(+ -5%,8P4R)R-PIN
C11,C72,C151,C195	CH51004MA32	CAPACITOR CHIP 1uf 25V(+ -20%,Y5V,0805)
C13,C14,C15,C16,C17	CH41004Z931	CAP CHIP 0.1u,25V(+80-20%,Y5V,0603)
C18,C19,C20,C22,C42		
C43,C73,C74,C75,C76		
C78,C82,C88,C93,C95		
C96,C97,C98,C100,C101		
C103,C106,C108,C110,C111		
C117,C118,C119,C120,C121		
C126,C136,C144,C149,C155		
C156,C182,C185,C186,C187		
C188,C189,C190		
C138	CH22206K917	CAP CHIP 2200P 50V(+ -10%,X7R,0603)
C134	CH21006K917	CAP CHIP 1000P 50V(+ -10%,X7R,0603)
C21,C142,C143,C194	CH41004MA14	CAPACITOR CHIP 0.1u 25V(+ -20%,X7R,0805)
C1,C2,C3,C4,C105	CH31006K919	CAP CHIP 0.01U 50V(+ -10%,X7R,0603)
C109,C112,C114,C130,C131		
C146	CH11206J908	CAPACITOR CHIP 120P 50V(+ -5%,NPO,0603)
C102,C107	CH00506J904	CAPACITOR CHIP 5P 50V(+ -5%,NPO,0603)
C99,C104	CH04706J902	CAPACITOR CHIP 47P 50V(+ -5%,NPO,0603)
C84,C91	CH03306J905	CAPACITOR CHIP 33P 50V(+ -5%,NPO,0603)
C9	CH11006J901	CAPACITOR CHIP 100P 50V(+ -5%,NPO,0603)
C113,C116,C129,C132,C135	CH01206J906	CAPACITOR CHIP 12P 50V(+ -5%,NPO,0603)
C137,C139,C141,C145,C154		
C184,C196,C197		
C24,C25,C26,C27,C28	CH01506JB06	CAP CHIP 15P 50V(+ -5% C0G 0402)
C29,C30,C31,C32,C33		
C34,C35,C36,C37,C38		
C39,C44,C45,C46,C47		
C48,C49,C50,C51,C52		
C53,C54,C55,C56,C57		
C58,C59,C60,C61,C62		
C63,C64,C65,C66,C67		
C71,C77,C79,C81,C83		
C86,C87,C89,C157,C158		
C159,C160,C161,C162,C163		

C164,C165,C166,C167,C168		
C169,C170,C171,C172,C173		
C174,C175,C176,C177,C178		
C179,C180,C181		
C5,C6,C7,C8,C40	CC63303MD24	CAP ELEC 33U 16V(+20%,105C,5*7,LESR)
C69,C80,C94		
C68,C70,C90,C92	CC71004MD50	CAP ELEC 100U 25V(+20%,105C,6*11,LESR)
C128	CC81001MD71	CAP ELEC DIP 1000U 6.3V +20% 105C 8*11.5
C23,C140,C153,C183,C191	CC74704MD29	CAP. ELEC DIP 470U 16V(+20%,105C,8*9)MB
D1,D2,D3,D4	BD05232BZ09	DIODE,ZENER,SMD MMBZ5232B(5.6V,SOT23)
D6,D7	BC1SS355Z05	DIODE SMD 1SS355(80V,100MA)
D8	BCRB081LZ02	DIODE SMD RB081L-20(20V,5.0A,VF:0.45V)
D9	BCAN202UZ01	DIODE,SMD DAN202U(80V,100mA,SMD)
Q6	BAM9435YZ09	TRANSISTOR MOSFET SI9435DY(-30V,5.1A)
Q13	BAM9410YZ02	TRANSISTOR MOSFET SI9410DY(30V,7A)
Q1,Q14	BAN70020T04	TRANSISTOR MOSFET 2N7002(60V,0.115A)
Q8,Q11	BA144EUAZ04	TRANSISTOR SMD DTC144EUA(50V,30MA)
Q7	BA039040Z01	TRANSISTOR,SMD MMBT3904(40V,200mA)
Q9	BA039060Z01	TRANSISTOR,SMD MMBT3906(40V,200mA)
U9,U14	AL07WZ14002	IC(6P) NC7WZ14P6X TINYLOGIC(SC70-6)
U12	AL001563001	IC(8P) AIC1563CS(SOP8)
U4	AKE1A8S0J07	IC EEPROM(8P) HT24LC16-SOP(2K*8)SOP
U11	AKE2A1S0J08	IC EEPROM(8P)HT24LC02-SOP 2K*1(SOP)
U1,U2	AJVDM830K04	IC(56P) THC63LVDM83A(SSOP)24bits,3.3V
U5,U6	AL001117078	IC(3P) AIC1117CY(SOT-223)
U8	AJ02120^C01	IC(208P) GM2120BD(162MHZ,PQFP)
U10	AL000809049	IC(3P) MAX809T(SOT23,3.08V)
X1	BG614318D55	XTAL DIP 14.318MHZ(+30PPM,07010-X-136-2
	DALM7SMB4B0	PCB 4 layer T1.6mm 135x115mm

13. SPARTS PARTS LIST

	Part No.	Description	Remark
1	45LM7AB0008	LM7S AUDIO/B ASSY	Audio Board
2	33LM7BB0001	LM7S BUTTON/B ASSY	Button Board
3	31L7EMB0007	L7E MB ASSY	MB Board
4	AA0170E1003	LCD(TFT) 17" QD170E1LG03 REV:A	LCD panel
5	AS022167304	INV MODULE(AMB)LM7S(12V,V=675V,A2A)	Inverter
6	AG12042BY21	ADP 12V 4.16A SLS9901B12157 90~264V 3A3A	Adapter
7	35L7EFPTN07	L7EA FRONT PANEL ASSY	Front panel assembly
8	EAL7E001033	LCD BEZEL-1 L7E(EAL7E001,REV3B)	Bezel
9	42L7ESBTN07	L7EA STAND BASE ASSY	Stand assembly
10	EALM700602	STAND BASE L7EA (EALM7006,REV3C)	
11	EAL7E002030	LCD COVER L7EA (EAL7E002,REV3D)	Rear cover
12	HAL7E002013	PE BAG L7E(HAL7E002,REV3C)	
13	HBL7E001018	END CAP(R) L7E(HBL7E001,REV3A)	
14	HBL7E002014	END CAP(L) L7E(HBL7E002,REV3A)	
15	HDL7E003012	MANUAL L7EA (HDL7E003,REV3A)	
16	HFL7E003014	CARTON L7EA (HFL7E003,REV3A)	
17	DM333180103	POWER CORD 3P 1.8M(USA) V04VS330008180QD	
18	DD0L7EPC004	CABLE ASSY L7E MB-VGA(15/15P,REV3A)428U	
19	DD0L7EPC101	CABLE ASSY L7E PC-MONITOR REV:3A 428U	
20	EALM7005027	NECK COVER L7EA (EALM7005,REV3E)	
21	EALM7004021	NECK BEZEL L7EA (EALM7004,REV3C)	