

# Acer AL1916e

## Service Guide

Service guide files and updates are available on the CSD web: for more information, Please refer to <http://csd.acer.com.tw/>



100% Recycled Paper

## **Copyright**

Copyright ©2003 by Acer Incorporated. All rights reserved. No part of this publication may be reproduced, transmitted, transcribed, stored in a retrieval system, or translated into any language or computer language, in any form or by any means, electronic, mechanical, magnetic, optical, chemical, manual or otherwise, without the prior written permission of Acer Incorporated.

## **Disclaimer**

The information in this guide is subject to change without notice. Acer Incorporated makes no representations or warranties, either expresses or implied, with respect to the contents hereof and specifically disclaims any warranties of merchantability or fitness for any particular purpose. Any Acer Incorporated software described in this manual is sold or licensed “as is”. Should the programs prove defective following their purchase, the buyer (and not Acer Incorporated, its distributor, or its dealer) assumes the entire cost of all necessary servicing, repair, and any incidental or consequential damages resulting from any defect in the software.

Acer is a registered trademark of Acer Corporation.

Intel is a registered trademark of Intel Corporation.

Pentium and Pentium II/III are trademarks of Intel Corporation.

Other brand and product names are trademarks and/or registered trademarks of their respective holders.

## Conventions

The following conventions are used in this manual:

<b>Screen messages</b>	Denotes actual messages that appear on screen
<b>Note</b>	Gives bits and pieces of additional information related to the current topic.
<b>Warning</b>	Alerts you to any damage that might result from doing or not doing specific actions.
<b>Caution</b>	Gives precautionary measures to avoid possible hardware or software problems.
<b>Important</b>	Reminds you to do specific actions relevant to the accomplishment of procedures.

## **Preface**

Before using this information and the product it supports, please read the following general information.

1. this Service Guide provides you with all technical information relating to the BASICCONFIGURATION decided for Acer's "global" product offering. To better fit local market requirements and enhance product competitiveness, your regional office MAY have decided to extend the functionality of a machine (e.g. add-on card, modem, or extra memory capability). These LOCALIZED FEATURES will NOT be covered in this generic service guide. In such cases, please contact your regional offices or the responsible personnel/channel to provide you with further technical details.
2. please not WHEN ORDERING FRU PARTS, that you should check the most up-to-date information available on your regional web or channel. If, for whatever reason, a part number change is made, it will not be noted in the printed Service Guide, for ACER- AUTHORIZED SERVICE PROVIDERS, your Acer office may have a DIFFERENT part number code to those given in the FRU list of this printed Service Guide. You MUST use the list provided by your regional Acer office to order FRU parts for repair and Service of customer machines.

## **WARNING: (FOR FCC CERTIFIED MODELS)**

**NOTE:** this equipment has been tested and found to comply with the limits for a Class B digital device, pursuant to Part 15 of the FCC Rules. These limits are designed to provide reasonable protection against harmful interference in a residential installation. This equipment generates, uses and can radiate radio frequency energy, and if not installed and used in accordance with the instructions, may cause harmful interference to radio communications. However, there is no guarantee that interference will not occur in a particular installation. If this equipment does cause harmful interference to radio or television reception,

Which can be determined by turning the equipment off and on, the user is encouraged to try to correct the interference by one or more of the following measures:

1. Reorient or relocate the receiving antenna.
2. Increase the separation between the equipment and receiver.
3. Connect the equipment into an outlet on a circuit different from that to which the receiver is connected.
4. Consult the dealer or an experienced radio/TV technician for help.

## **NOTICE:**

1. The changes or modifications not expressly approved by the party responsible for compliance could void the user's authority to operate the equipment.
2. Shielded interface cables and AC power cord, if any, must be used in order to comply with the emission limits.
3. The manufacturer is not responsible for any radio or TV interference caused by unauthorized modification to this equipment. It is the responsibility of the user to correct such interference.

As an ENERGY STAR® Partner our company has determined that this product meets the ENERGY STAR® guidelines for energy efficiency.

## **WARNING:**

To prevent fire or shock hazard, do not expose the monitor to rain or moisture. Dangerously high voltages are present inside the monitor. Do not open the cabinet. Refer servicing to qualified personnel only.

## PRECAUTIONS

- Do not use the monitor near water, e.g. near a bathtub, washbowl, kitchen sink, laundry tub, Swimming pool or in a wet basement.
- Do not place the monitor on an unstable trolley, stand, or table. If the monitor falls, it can injure a person and cause serious damage to the appliance. Use only a trolley or stand recommended by the manufacture or sold with the monitor. If you mount the monitor on a wall or shelf, use a mounting kit approved by the manufacture and follow the kit instructions.
- Slots and openings in the back and bottom of the cabinet area provided for ventilation. To ensure reliable operation of the monitor and to protect it from overheating, be sure these openings are not blocked or covered. Do not place the monitor on a bed, sofa, rug or similar surface. Do not place the monitor near or over a radiator or heat register. Do not place the monitor in a bookcase or cabinet unless proper ventilation is provided.
- The monitor should be operated only from the type of power source indicated on the label. If you are not sure of the type of power supplied to your home, consult your dealer or local power company.
- The monitor is equipped with a three-pronged grounded plug, a plug with a third (grounding) pin. This plug will fit only into a grounded power outlet as a safety feature. If your outlet does not accommodate the three-wire plug, have an electrician install the correct outlet, or use an adapter to ground the appliance safely. Do not defeat the safety purpose of the grounded plug.
- Unplug the unit during a lightning storm or when it will not be used for long periods of time. This will protect the monitor from damage due to power surges.
- Do not overload power strips and extension cords. Overloading can result in fire or electric shock.
- Never push any object into the slot on the monitor cabinet. It could short circuit parts causing a fire or electric shock. Never spill liquids on the monitor.
- Do not attempt to service the monitor yourself; opening or removing covers can expose you to dangerous voltages and other hazards. Please refer all servicing to qualified service personnel.
- To ensure satisfactory operation, use the monitor only with UL listed computers which have appropriate configured receptacles marked between 100-240V AC, Min. 3.5A.
- The wall socket shall be installed near the equipment and shall be easily accessible.
- For use only with the attached power adapter (output 12V DC) which have UL,CSA listed license

## **SPECIAL NOTES ON LCD MONITORS**

The following symptoms are normal with LCD monitor and do not indicate a problem.

### **NOTES**

- Due to the nature of the fluorescent light, the screen may flicker during initial use. Turn off the Power Switch and then turn it on again to make sure the flicker disappears.
- You may find slightly uneven brightness in the screen depending on the desktop pattern you use.
- The LCD screen has effective pixels of 99.99% or more. It may include blemishes of 0.01% or less such as a missing pixel or a pixel lit all of the time.
- Due to the nature of the LCD screen, an afterimage of the previous screen may remain after switching the image, when the same image is displayed for hours. In this case, the screen is recovered slowly by changing the image or turning off the Power Switch for hours.

# *Table of contents*

<b>Chapter 1 MONITOR FEATURE .....</b>	<b>9</b>
<b>Chapter 2 OPERATING INSTRUTION .....</b>	<b>16</b>
<b>Chapter 3 MACHINE ASSEMBLY .....</b>	<b>.21</b>
<b>Chapter 4 TROUBLE SHOOTING .....</b>	<b>32</b>
<b>Chapter 5 CONNECTOR INFORMATION .....</b>	<b>34</b>
<b>Chapter 6 FRU LIST .....</b>	<b>35</b>
<b>Chapter 7 SCHEMATIC DIAGRAM .....</b>	<b>36</b>
<b>Chapter 8 POWER BOARD INFORMATION.....</b>	<b>40</b>



## Monitor Feature

	Driving system	TFT Color LCD
LCD Panel	Size	19"
	Pixel pitch	0.294 mm
	Viewable angle	140 (H), 125 (V) (Typical)
	Brightness	250 cd/m <sup>2</sup> (Typical)
	Contrast Ratio	550:1 (Typical)
	Response time	8ms (Tr+Tf)
	Input	Video
Separate Sync		H/V TTL
	H-Frequency	31-81KHZ
	V-Frequency	56-75HZ
Display Color		16.2 million Colors
Maximum Dot Clock ®		135MHz
Max Resolution		1280x1024@75HZ
Plug & Play		VESA DDC2B
EPA ENERGY STAY	ON Mode	<40W
	OFF Mode	<1W
Audio output		Rated Power 2.0W rms(Per channel)
Input Connector		D-Sub 15 pin,
Input Video Signal		Analog : 0.7Vp-p,75OHM
Screen Size (Active)	Horizontal : 376.32mm	
	Vertical : 301.056mm	
Power Source		90~264 Vac, 47~63HZ
Environmental Considerations		Operating Temp : 5 to 40 degree ; Storage Temp : -20 to 60 degree ; Operating Humidity : 15% to 85%
Weight (N.W.)		4.9kg
Dimension		411.6(W) x 407.9(H) x 182(D) mm

External Controls :	Switch	<ul style="list-style-type: none"> <li>* Power Switch</li> <li>* MENU / EXIT</li> <li>* ^ / Volume</li> <li>* v / Volume</li> <li>* AUTO / ENTER</li> </ul>
		<ul style="list-style-type: none"> <li>* Contrast/brightness</li> <li>* Focus</li> <li>* Clock</li> <li>* H.Position</li> <li>* W.Position</li> <li>* Language</li> <li>* OSD Color temperature</li> <li>* OSD Position &amp; Timeout</li> <li>* Auto Config</li> <li>* Input</li> <li>* Information</li> <li>* Reset</li> <li>* Exit</li> </ul>
Regulatory Compliance		cUL, FCC, TUV, CE, ISO13406-2

## Timings

The product has 26 memory modes in total. 16 modes are preset and 10 modes are user definable.

MODE NO.	1	2	3	4
RESOLUTION	<b>720 x 400</b>	<b>640 x 480</b>	<b>640x480</b>	<b>640 x 480</b>
Dot clock(MHz)	28.321	25.175	30.240	<b>31.500</b>
f h	<b>31.469kHz</b>	<b>31.469kHz</b>	<u>35.0kHz</u>	37.861kHz
A ( us )	31.78(900dots)	31.778 (800 dots)	28.571(864 dots)	26.413 (832 dots)
B ( us )	3.813(108dots)	3.813 (96 dots)	2.116 (64 dots)	1.270(40 dots)
C ( us )	1.907(54dots)	1.907 (48 dots)	3.175 (96 dots)	4.064(128 dots)
D ( us )	25.42(720dots)	25.422 (640 dots)	21.164 (640 dots)	20.317(640 dots)
E ( us )	0.636(18dots)	0.636 (16 dots)	2.116 (64 dots)	0.762(24 dots)
f v	<b>70Hz(70.087)</b>	<b>60Hz (59.940)</b>	<b>66.7 HZ (66.667)</b>	<b>72.809Hz</b>
O ( ms )	14.27(449 lines)	16.683 (525 lines )	15.000 (525 lines )	13.735(520 lines)
P ( ms )	0.064(2 lines)	0.064 (2 lines )	0.086 (3 lines )	0.079(3 lines)
Q ( ms )	1.112(35 lines)	1.049 (33 lines )	1.114 (39 lines )	0.739(28 lines)
R ( ms )	12.71(400 lines)	15.253 (480 lines )	13.714 (480 lines )	12.678(480 lines)
S ( ms )	0.384(12 lines)	0.317 ( 10 lines)	0.086 (3 lines )	0.237(9 lines)
SYNC. H/V	-/+	- / -	+ / +	- / -
POLARITY			Or - / -	
SEP . SYNC	Y	Y	Y	Y

MODE NO.	5	6	7	8
RESOLUTION	<b>640 x 480</b>	<b>800 x 600</b>	<b>800 x 600</b>	<b>800 x 600</b>
Dot clock(MHz)	<b>31.500</b>	<b>36.000</b>	<b>40.000</b>	49.500
f h	37.500kHz	35.16kHz	37.879kHz	<b>46.875kHz</b>
A ( us )	26.667(840 dots)	28.44(1024 dots)	26.40 (1056 dots)	21.333 (1056dots)
B ( us )	2.032 (64 dots)	2.00(72 dots)	3.200 (128 dots)	1.616 (80 dots)

C ( us )	3.810 (120 dots)	3.56(128 dots)	2.200 ( 88 dots)	3.232 (160 dots)
D ( us )	20.317 (640 dots)	22.22(800 dots)	20.00 ( 800 dots)	16.162 (800 dots)
E ( us )	0.508 (6 dots)	0.67(24 dots)	1.000 (40 dots)	0.323 (16 dots)
f v	<b>75Hz (75)</b>	<b>56.25</b>	<b>60Hz (60.316)</b>	<b>75Hz (75.000)</b>
O (ms )	13.333 (500 lines)	17.78(625 lines)	16.58 (628 lines)	13.333 (625lines)
P ( ms )	0.080 (3 lines)	0.06(2 lines)	0.106 (4 lines)	0.064 (3 lines)
Q ( ms )	0.427 (16 lines)	0.63(22 lines)	0.607 (23 lines)	0.448 (21 lines)
R ( ms )	12.80 (480 lines)	17.07(600 lines)	15.84 (600 lines)	12.80 (600lines)
S ( ms )	0.027 ( 1line )	0.03(1 line)	0.026 (1 line )	0.021 (1 line )
SYNC. H/V	- / -	+ / +	+ / +	+ / +
POLARITY				
SEP . SYNC	Y	Y	Y	Y

MODE NO.	9	10	11	12
RESOLUTION	<b>800 x 600</b>	<b>832 x 624</b>	<b>1024 x 768</b>	<b>1024 x 768</b>
Dot clock(MHz)	50.000	57.283	65.000	75.000
f h	<b>48.077kHz</b>	<b>49.72kHz</b>	<b>48.363kHz</b>	<b>56.48kHz</b>
A ( us )	20.80 (1040dots)	20.11(1152 dots)	20.677(1344 dots)	17.71(1328 dots)
B ( us )	2.400 ( 120 dots)	1.12(64 dots)	2.092(136 dots)	1.81(136 dots)
C ( us )	1.280 (64)	3.91(224 dots)	2.462(160 dots)	1.92(144 dots)
D ( us )	16.00 (800 dots)	14.52( 832 dots )	15.754(1024 dots)	13.65(1024 dots)
E ( us )	1.120 (56 dots)	0.56(32 dots )	0.369(24 dots)	0.32(24 dots)
f v	<b>72Hz (72.188)</b>	<b>74.55Hz</b>	<b>60.004Hz</b>	<b>70.07Hz</b>
O (ms )	13.85 (666 lines)	13.41(667 lines)	16.666(806 lines)	14.27(806 lines)
P ( ms )	0.125 (6 lines)	0.06(3 lines)	0.124(6 lines)	0.11(6 lines)
Q ( ms )	0.478 (23 lines)	0.78(39 lines)	0.600(29 lines)	0.51(29 lines)
R ( ms )	12.48 (600 lines)	12.55 (624 lines)	15.880(768 lines)	13.60(768 lines)
S ( ms )	0.770 ( 37 line )	0.02(1 line)	0.062(3 lines)	0.05(3 lines)
SYNC. H/V	+ / +	+ / +	- / -	- / -
POLARITY				
SEP . SYNC	Y	Y	Y	Y

MODE NO.	13	14	15	16
RESOLUTION	<b>1024 x 768</b>	<b>1280 x 1024</b>	<b>1280 x 1024</b>	<b>1152 x 864</b>
Dot clock(MHz)	78.750	108.000	135	108.00
f h	<b>60.02kHz</b>	<b>63.981kHz</b>	<b>79.976KHz</b>	<b>67.5 KHz</b>
A ( us )	16.66(1312 dots)	15.630 (1688 dots)	12.504 (1688 dots)	14.815(1600 dots)
B ( us )	1.22 (96 dots)	1.037 (112 dots)	1.067 (144 dots)	1.185(128 dots)
C ( us )	2.23 (176 dots)	2.296 (248 dots)	1.837 (248 dots)	2.370(256 dots)
D ( us )	13.00 (1024 dots)	11.852 (1280 dots)	9.481 (1280dots)	10.667(1152 dots)
E ( us )	0.20 (16 dots)	0.444 (48 dots)	0.119 (16 dots)	0.593(64 dots)
f v	<b>75.03Hz</b>	<b>60.020Hz</b>	<b>75.025 Hz</b>	<b>75.06 Hz</b>
O ( ms )	13.33 (800 lines)	16.661 (1066 lines)	13.329 (1066 lines)	13.333(900 lines)
P ( ms )	0.05 (3 lines)	0.047 ( 3 lines)	0.038 (3 lines)	0.044(3 lines)
Q ( ms )	0.47 (28 lines)	0.594 ( 38 lines)	0.475 (38 lines)	0.474(32 lines)
R ( ms )	12.80 (768 lines)	16.005 (1024 lines)	12.804(1024 lines)	12.800(864 lines)
S ( ms )	0.02 (1 lines)	0.016 (1 line )	0.013 (1 lines)	0.015(1 lines)
SYNC. H/V	-/-	+/+	+/+	+/+
POLARITY				
SEP . SYNC	Y	Y	Y	Y

A \_\_\_\_\_ : H-Total      O \_\_\_\_\_ : V-Total  
 B \_\_\_\_\_ : H- Sync width      P \_\_\_\_\_ : V- Sync width  
 C \_\_\_\_\_ : H- Back porch      Q \_\_\_\_\_ : V- Back porch  
 D \_\_\_\_\_ : H- Video width      R \_\_\_\_\_ : V- Video width  
 E \_\_\_\_\_ : H- Front porch      S \_\_\_\_\_ : V- Front porch

# Monitor Block Diagram

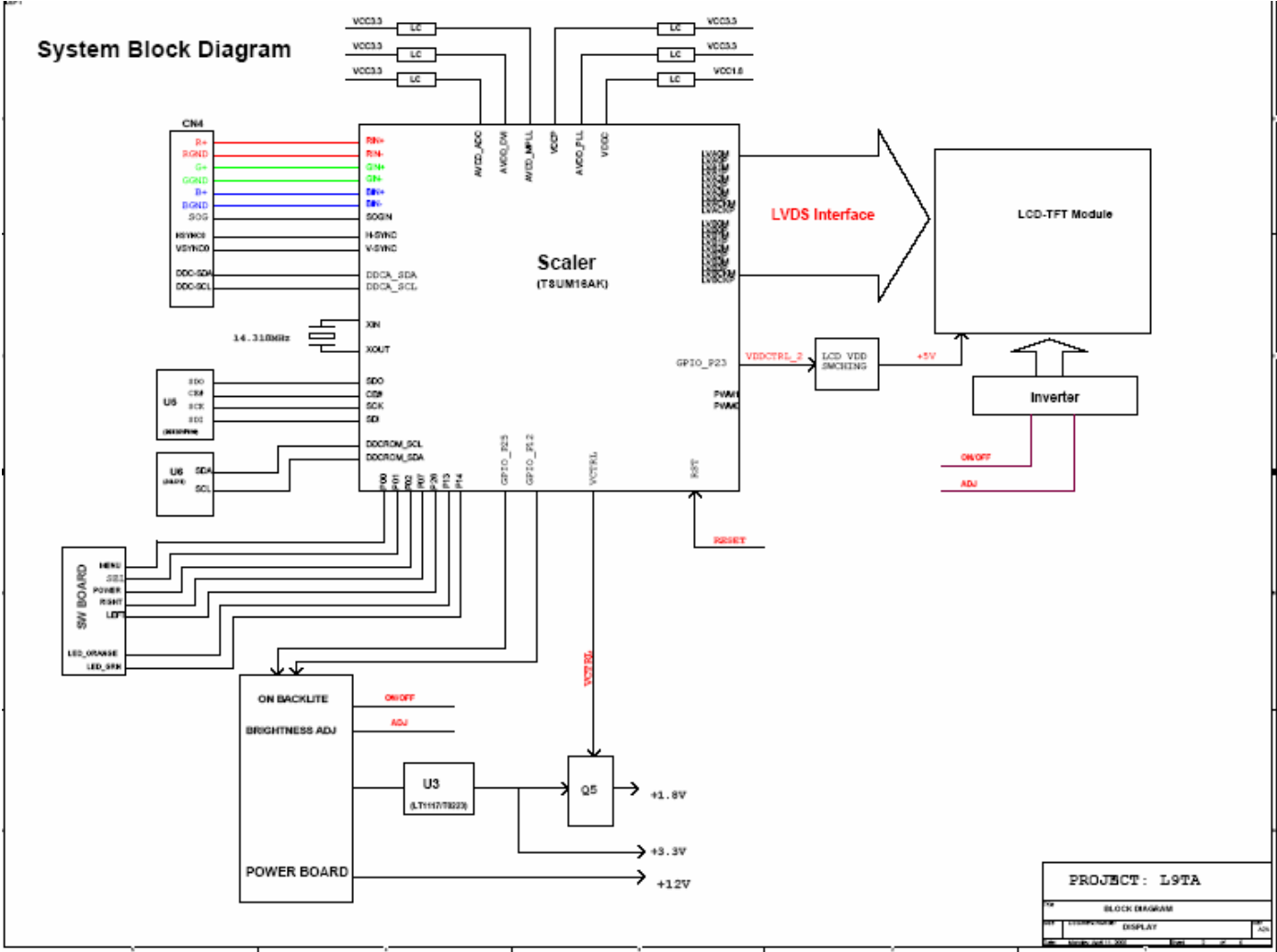

# PCB CONDUCTOR VIEW

## Main Board

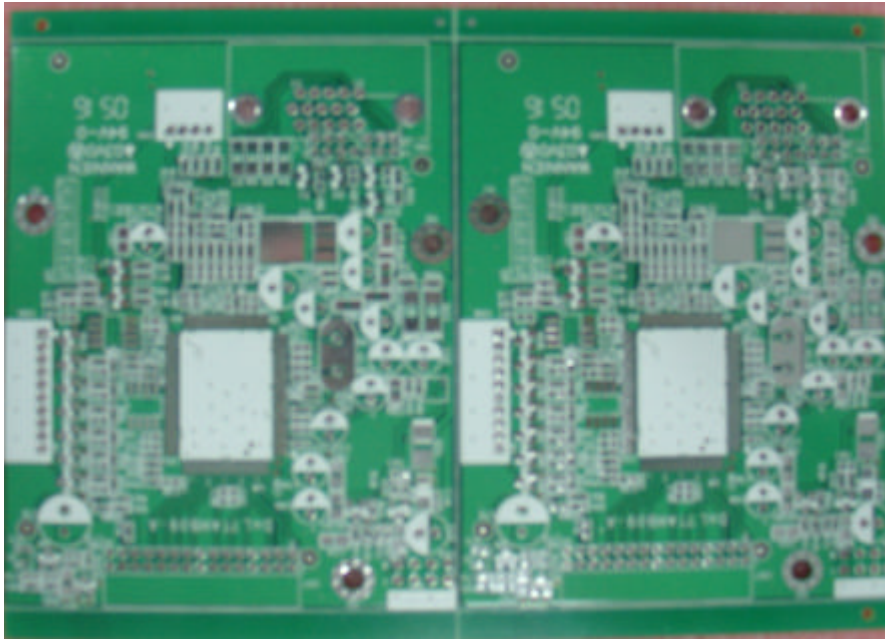

## Button Board

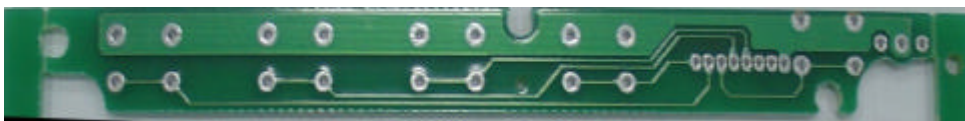

## OPERATING INSTRUCTIONS

### Front Panel Definition

This Section defines the front panel User Interface for Led Indicator and Key function.

Key Definition:

There are five keys defined in this system and described bellows.

- \* Adjusting display settings

### External Controls

?		POWER	Power on/off Blue: power on Orange: in sleep mode
?	MENU	OSD Function	Press to view OSD. Press again to exit a selection in OSD.
?	^	UP/ PLUS	If OSD is active, press to select or adjust OSD options. If OSD is inactive, press once, then press the buttons marked ^ oi v to adjust the volume.
?	v	DOWN / MINUS	If OSD is active, press to select or adjust OSD options. If OSD is inactive, press once, then press the buttons marked ^ oi v to adjust the volume.
?	AUTO	AUTO	If OSD is active, press to enter a selection in OSD. If OSD is inactive, press and the monitor will automatically optimize the position, focus and clock of your display.



## OSD Menu

### Picture

#### **Brightness:**

This adjusts the brightness of the picture on the screen.

#### **Contrast:**

This adjusts dark and light shades of color relative to each other to achieve a comfortable contrast.

#### **Color temp. :**

There are three ways of adjusting color:

Warm (Reddish white)

Cool (Bluish white)

User : You can adjust the colors red, green and blue to the intensity you desire.

#### **Focus:**

This removes any horizontal distortion and makes the picture clear and sharp.

#### **Clock:**

If there are any vertical stripes seen on the background of the screen this renders them less noticeable by minimizing their size. It also changes the size of the horizontal screen.

#### **H-Position:**

This adjusts the horizontal screen position.

#### **V-Position:**

This adjusts the vertical screen position.

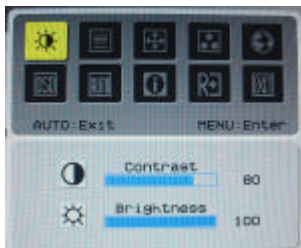



## Option

### Auto Configuration:

System runs auto-configuration.



### Reset:

Recall to default settings.



### Information:

This shows brief information on the screen.



## Setting

### Language:

Select the OSD menu language from

English, French, German, Italian, Spanish, Simplified Chinese, Traditional Chinese, Japanese and Russian.

### OSD H. Position

### OSD V. Position

### OSD Time-out

This changes the position of the OSD window on the screen and staying time.



## LED Definition

The system equips one dual color (blue/amber) led to indict system status and defined as bellows :

LED Color	System Status
Blue	System in normal operation mode
Amber	System in power-saving mode
Dark	System in power-off mode

## LOGO :

When the monitor is power on, the LOGO will be showed in the center, and disappear slowly.



## HOW TO OPTIMIZE THE DOS-MODE

### Plug and play

#### Plug & play DDC2B feature

This monitor is equipped with VESA DDC2B capabilities according to the VESA DDC STANDARD. It allows the monitor to inform the host system of its identity and, depending on the level of DDC used, communicate additional information about its display capabilities. The communication channel is defined in two levels, DDC2B.

The DDC2B is a bi-directional data channel based on the I<sup>2</sup>C protocol. The host can request EDID information over the DDC2B channel.

**THIS MONITOR WILL APPEAR TO BE NON-FUNCTIONAL IF THERE IS NO VIDEO INPUT SIGNAL. IN ORDER FOR THIS MONITOR TO OPERATE PROPERLY, THERE MUST BE A VIDEO INPUT SIGNAL.**

This monitor meets the Green monitor standards as set by the Video Electronics Standards Association(VESA) and/or the United States Environmental Protection Agency (EPA) and The Swedish Confederation Employees (NUTEK). This feature is designed to conserve electrical energy by reducing power consumption when there is no video-input signal present. When there is no video input signal this monitor, following a time-out period, will automatically switch to an OFF mode. This reduces the monitor's internal power supply consumption. After the video input signal is restored, full power is restored and the display is automatically redrawn. The appearance is similar to a "Screen Saver" feature except the display is completely off. The display is restored by pressing a key on the keyboard, or clicking the mouse.

## **USING THE RIGHT POWER CORD**

The accessory power cord for the Northern American region is the wallet plug with NEMA 5-15 style and is UL listed and CSA labeled. The voltage rating for the power cord shall be 125 volt AC.

Supplied with units intended for connection to power outlet of personal computer: Please use a cord set consisting of a minimum No. 18 AWG, type SJT or SVT three conductors flexible cord. One end terminates with a grounding type attachment plug, rated 10A, 250V,CEE-22 male configuration. The other end terminates with a molded-on type connector body, rated 10A, 250V, having standard CEE-22 female configuration.

Please note that power supply card needs to use VDE 0602, 0625, 0821 approval power cord in European counties.

## Machine assembly

**This chapter contains step-by-step procedures on how to assemble the monitor for maintenance and trouble shooting**

**NOTE : 1.** The screws for the different components vary in size. During the disassembly process, group the screws with the corresponding to avoid mismatch when putting back the components.

**2. Note :** The monitor surface is susceptible to scratching! Therefore, lay the monitor on a soft surface when mounting or removing the base.

**3.** Wear gloves.

**Front View : ( unit : mm )**

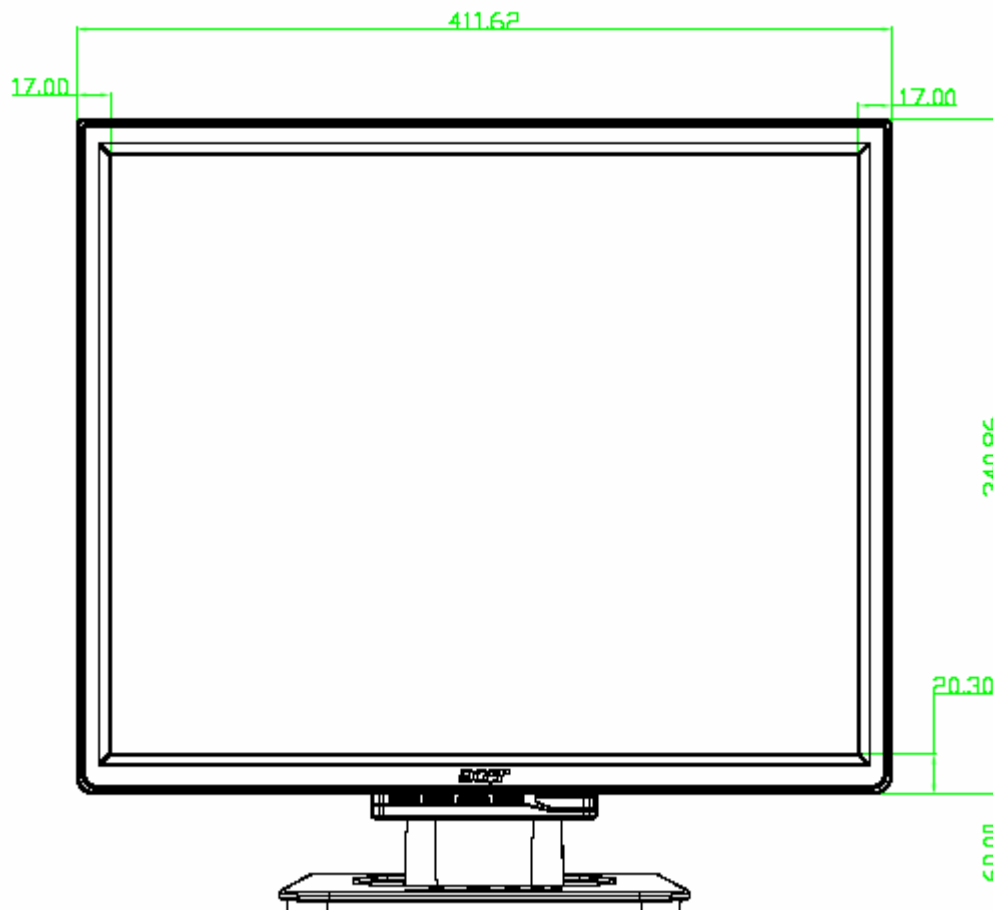

**Real View :**

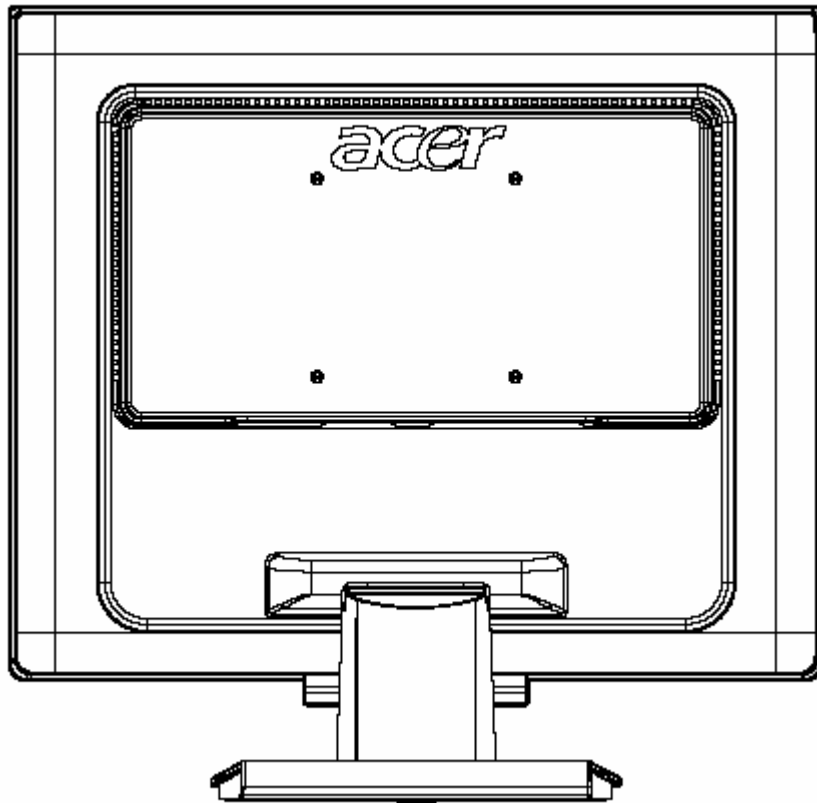

**Top View :**

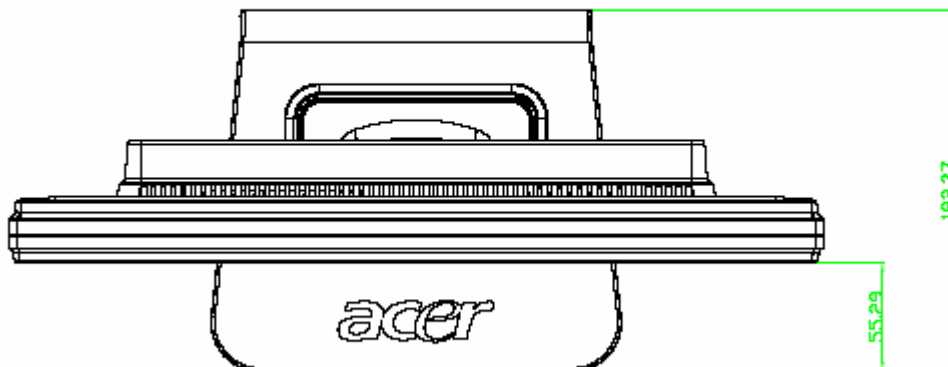

Side View : ( unit : mm )

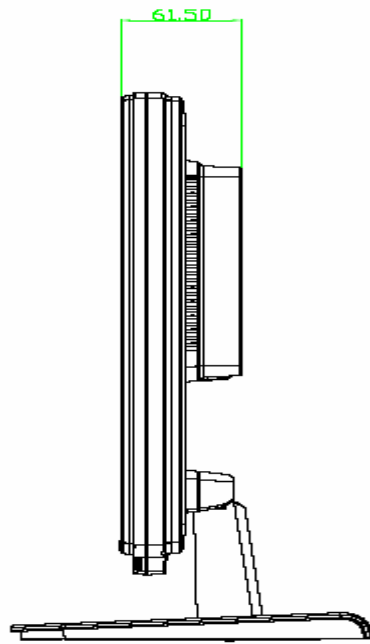

**Assembly process**

Picture	Description
<p>The top photograph shows a white PCB shield mounted inside a red frame. The bottom photograph shows a green PCB with several cables connected to it, including a black ribbon cable and a multi-colored flat cable.</p>	<ol style="list-style-type: none"> <li>1.[GET PCB SHIELD AND PUT IT IN THE MIDDLE OF CONVEYER]</li> <li>2.[GET M/B AND LCD CABLE, THEN INSERT LCD CABLE IN M/B CONNECTOR]</li> <li>3.[GET BUTTON CABLE, THEN INSERT IT IN M/B CONNECTOR]</li> <li>4.[ PUT M/B IN THE CONVEYER]</li> </ol>

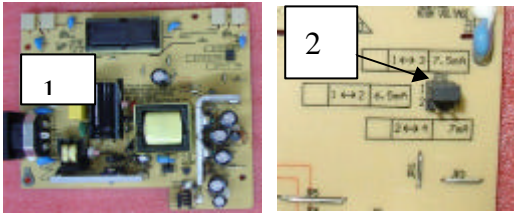

- 1.[GET POWER/B]
- 2.[INSERT JUMPER IN THE APPOINTED PLACE OF JP10 AT POWER/B]

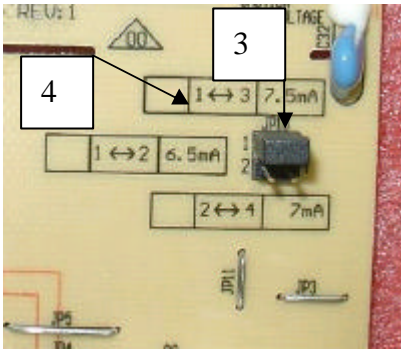

- 3.[GET AGGLUTINANT TO CONNECT THE JUMPER AND POWER/B]
- 4 .[MARK DOT IN THE PANE MARK OF POWER/B AS PICTURE SHOWS]

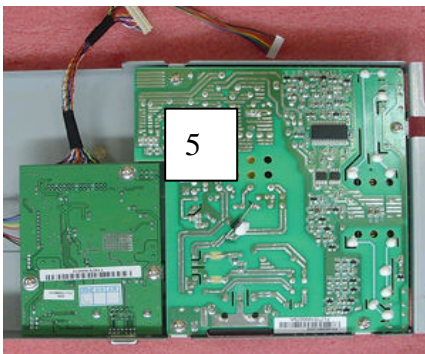

5. [ASSEMBLE POWER/B THAT IS OK IN THE SHIELDING]

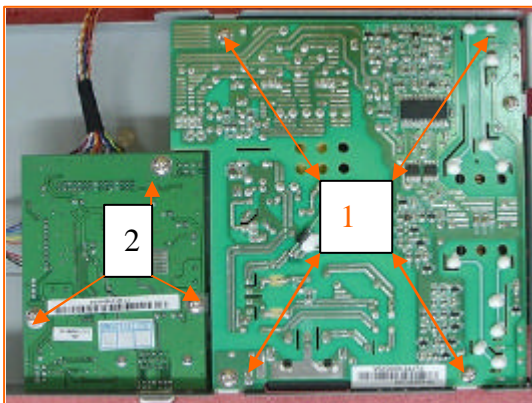

- 1.[FASTEN 3\*PCS SCREW(M3\*6-B) IN P/B]
- 2.[FASTEN 3\*PCS SCREW(M3\*6-B) IN M/B]



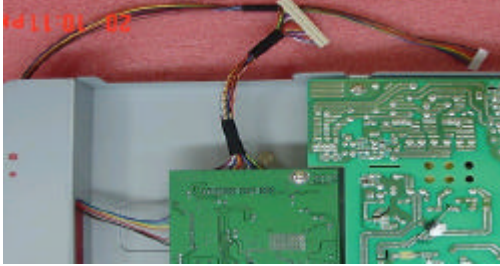
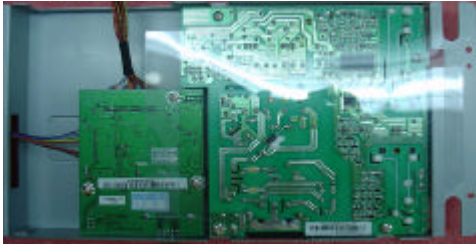

1.[FASTEN 1\*PCS SCREW(M3.5\*8-B) IN THE APPOINTED PLACE OF POWER/B]

2.[GET POWER/B MYLAR,TEAR OFF BACK TYPE AND STICK ON THE APPOINTED PLACE]

3.[GET BUTTON CABLE THROUGH THE APPOINTED HOLE]



1. [MOVE PCB SHIELD TO THE FRONT OF CONVEYER]

2 [GET PANEL AND PUT IT ON THE CONVEYER, THEN TEAR OFF THE INCOMING TAPE]



1.[UNCOVER PANEL PROTECTIVE FILM AND INSPECT IF PANEL IS DIRTY OR SCRATCHED]



2.[PASTE TYPE ON THE PROTECTIVE FILM TO FASTEN IT]

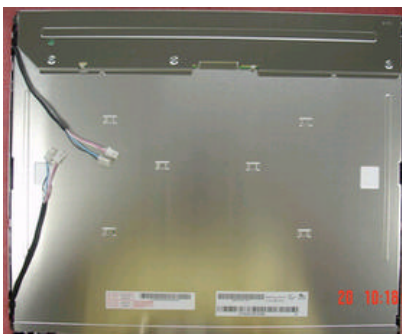

3.[TURN LCD,TEAR OFF INCOMING TYPE]



1.[GET LEFT BKT , LOCK 2\*PCS SCREW TO FASTEN IT ON THE PANEL]



1.[GET RIGHT BKT , LOCK 2\*PCS SCREW TO FASTEN IT ON THE PANEL]

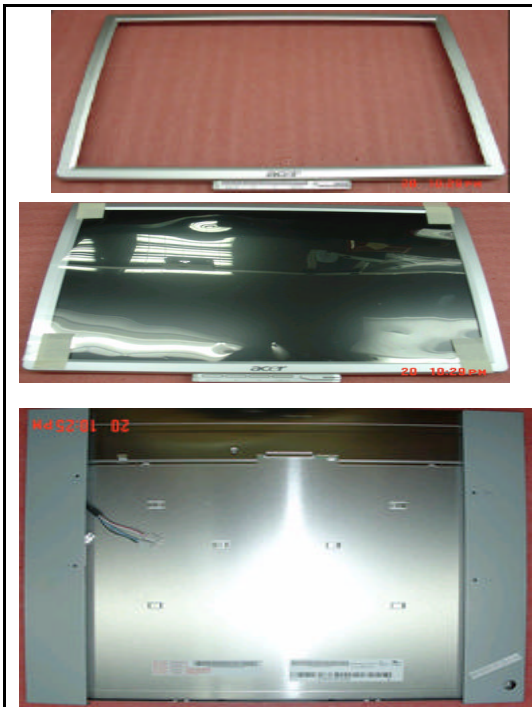

1. [GET BEZEL AND CHECK ITS APPEARANCE]
2. [ASSEMBLE BEZEL ON PANEL]
3. [STICK TYPE ON PROTECTIVE FILM]
4. [TURN LCD]
5. [FETCH TRAVEL CARD, TEAR OFF 1\*PCS APPOINTED S/N FROM TRAVEL CARD AND PASTE IT ON THE RIGHT BKT]



1. [SCAN S/N AND POWER CODE]
2. [FASTEN BKT AND BEZEL IN THE RIGHT SIDE WITH SCREW 3\*PCS ]



1.[FASTEN BKT AND BEZEL IN THE RIGHT SIDE WITH SCREW 3\*PCS ]

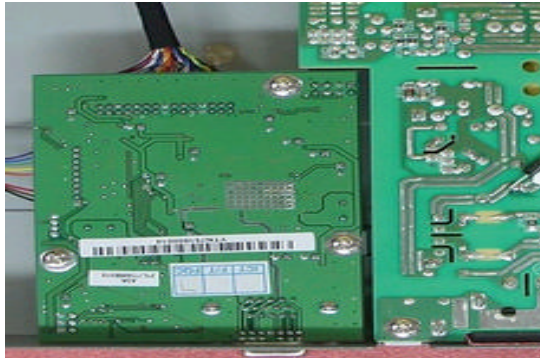

2.[SCAN S/N AND POWER CODE]

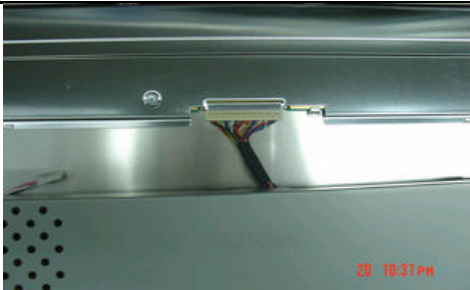

1.[GET SHIELD ON THE BKT R/L]

2. [INSERT LCD CABLE INTO PANEL CONNECTOR]



3. [STICK 1\*PCS YELLOW TAPE TO FASTEN LCD CABLE]



4. [TRIM WIRES AND ASSEMBLE SHIELDING IN RIGHT POSITION]



	<p>1. [LOCK 4*PCS SCREW(M3*3-I) TO FASTEN PCB SHIELD]</p>
  	<p>1.[FETCH BUTTON AND PUT IT IN THE MIDDLE OF CONVEYER]</p> <p>2.[FASTEN 2*PCS IO-NUT IN THE M/B]</p> <p>3.[INSERT UPPER CCFT CABLE IN POWER/B]</p>
 	<p>1.[FETCH BUTTON&amp;ITS CABLE,THEN ASSEMBLE THEM]</p> <p>2.[ASSEMBLE BUTTON/B AND BEZEL]</p> <p>3.[LOCK 3*PCS SCREW(F3*8-I) TO FASTEN BUTTON/B ON THE BEZEL]</p> <p>4.[STICK 1*PCS AL FOIL TO COVER UPPER CCFT CABLE]</p>

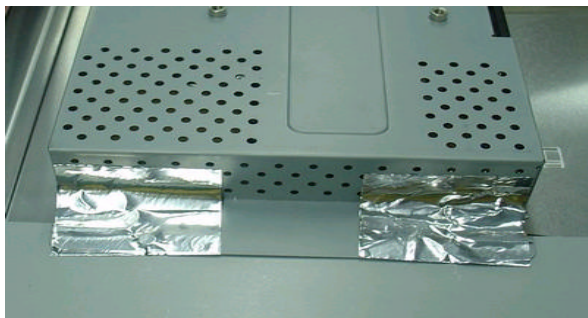
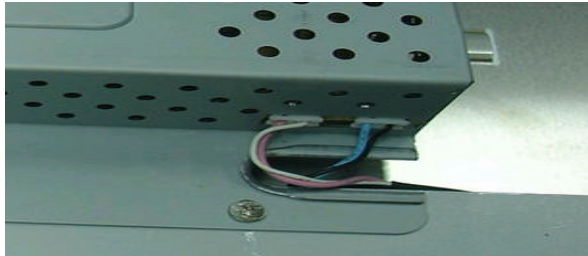
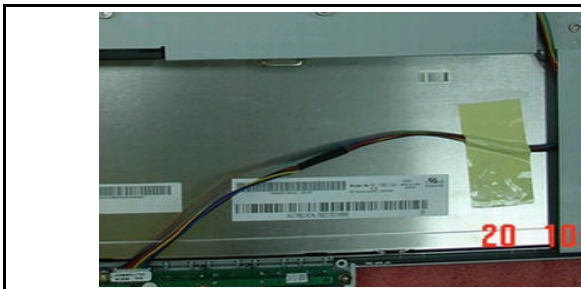



- 1.[PASTE YELLOW TAPE TO FASTEN BUTTON/B CABLE]
- 2.[INSERT LOWER CCFT CABLE IN POWER/B]
- 3.[STICK 1\*PCS AL FOIL TO COVER UPPER CCFT CABLE]



- 1.[GET LCD COVER AND INSPECT ITS APPEARANCE]
- 2.[ASSEMBLE LCD COVER TO BEZEL]



- 1.[FETCH TRAVEL CARD, TEAR OFF 1\*PCS APPOINTED S/N FROM TRAVEL CARD AND PASTE IT ON THE COVER]
- 2.[LOCK 2\*PCS SCREW (F3\*8-B) TO FASTEN BE ZEL AND LCD COVER]

	<p>1.[GET STAND NECK AND INSPECT IF IT IS DIRTY AND SCRATCHED, THEN PUT IT IN THE CONVEYER]</p>
 	<p>1.[AT FIRST CHECK IF 2*PCS SCREW IN THE COVER IS LOST]</p> <p>2. [LOCK 4*PCS SCREW (M4*8-B) TO FASTEN STAND NECK]</p> <p>3. [GET HINGE CAP AND ASSEMBLE IT ONTO HINGE ]</p>

## TROUBLE SHOOTING

This chapter provides trouble shooting information for AL1916

### 1. No Power

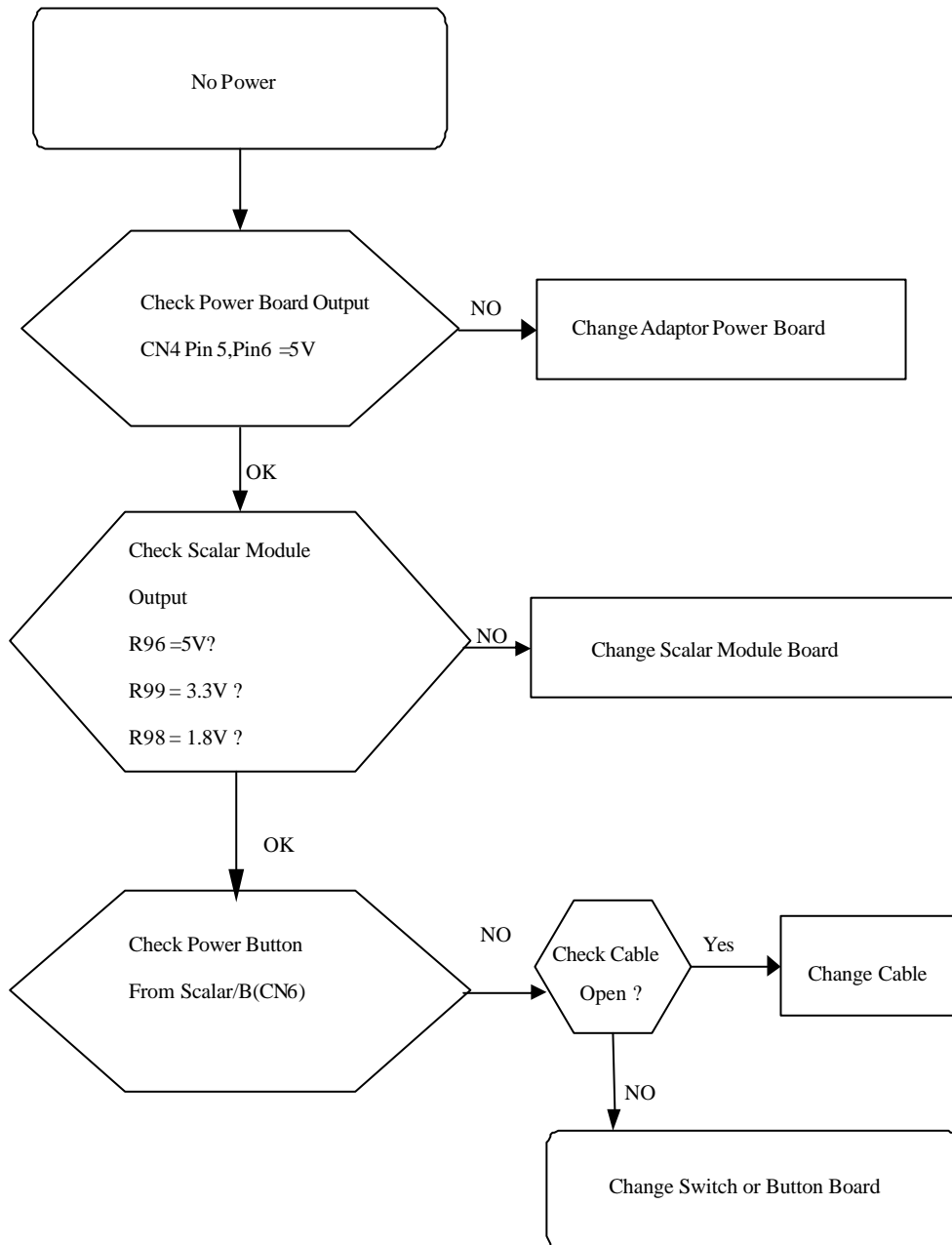



## 2. No Characters , Missing one color

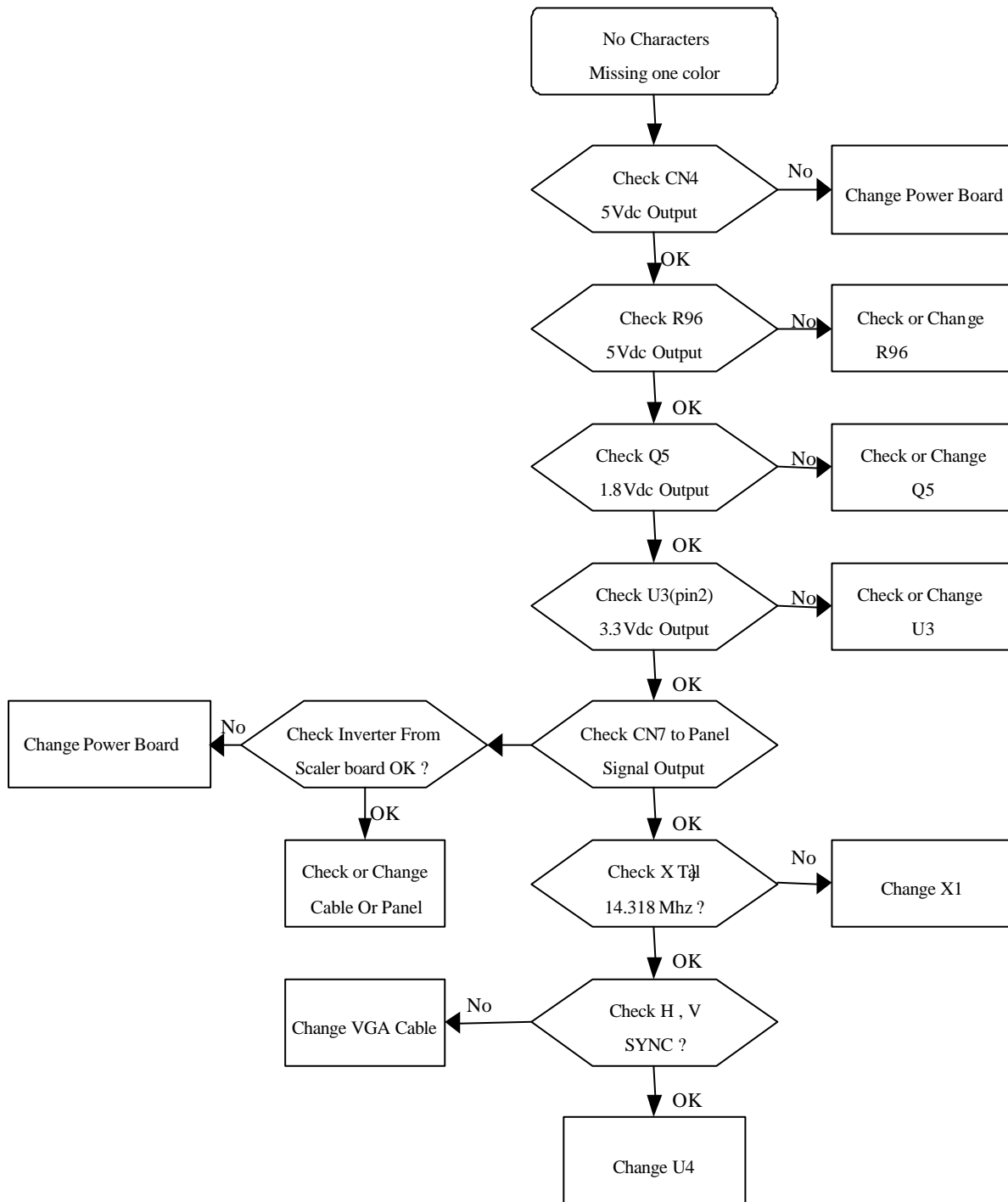

## Connector Information

### Phonejack stereo

PIN1. AC power cord : CEE22 typed connector

### Video signal connector 15P Mini D-Sub connector x 1

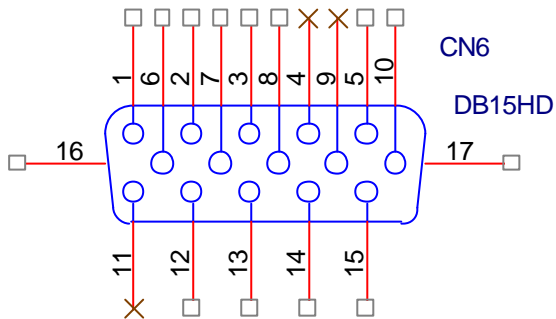

PIN	MNEMO	SIGNAL
1	RV	Red Video
2	GV	Green Video
3	BV	Blue Video
4	NC	None
5	GND	Ground(DDC return)
6	RG	Red GND
7	GG	Green GND
8	BG	Blue GND
9	+5V	+ 5V (for DDC)
10	SG	Svnc GND
11	NC	None
12	SDA	DDC Data
13	HS	Horizontal Svnc
14	VS	Vertical Svnc
15	SCL	DDC Clock

## FRU (Field Replaceable Unit) list

---

This chapter gives you the FRU (Field Replaceable Unit) listing in global configurations of AL1511. Refer to this chapter whenever ordering for parts to repair or for RMA (Return Merchandise Authorization).

NOTE : Please note WHEN ORDERING FRU PARTS, that you should check the most up-to-date information available on your regional web or channel(<http://aicsl.acer.com.tw/spl/>). For whatever reasons a part number change is made, it will not be noted in the printed Service Guide. For ACER-AUTHORIZED SERVICE PROVIDERS, your Acer office may have a DIFFERENT part number code to those given in the FRU list of this printed Service Guide. You MUST use the local FRU list provided by your regional Acer office to order FRU parts repair and service of customer machines.

NOTE: To scrap or to return the defective parts, you should follow the local government ordinance or regulations on how best to dispose it, or follow the rules set by your regional Acer office on how to return it.

## SCHEMATIC DIAGRAM

### Main Board Circuit

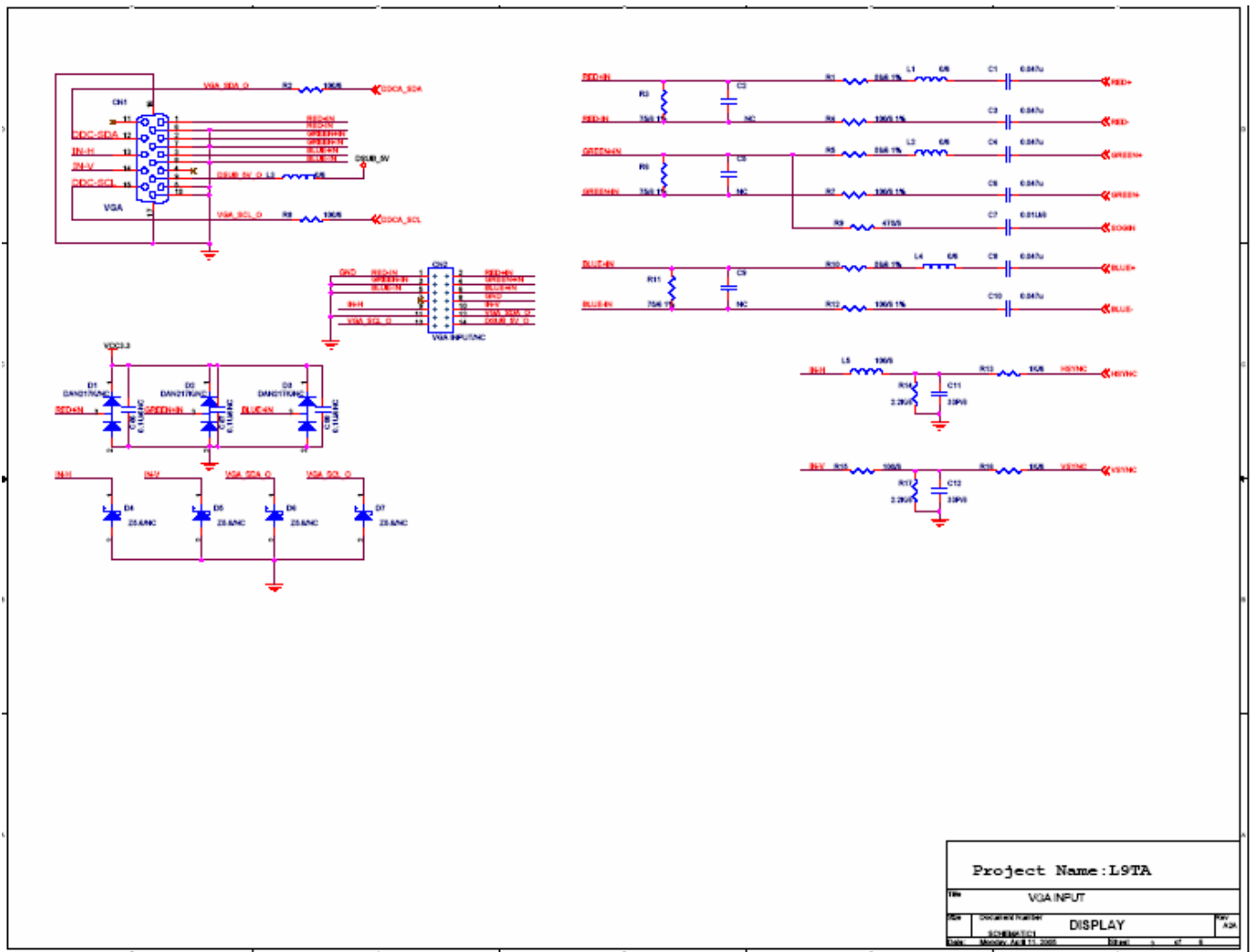

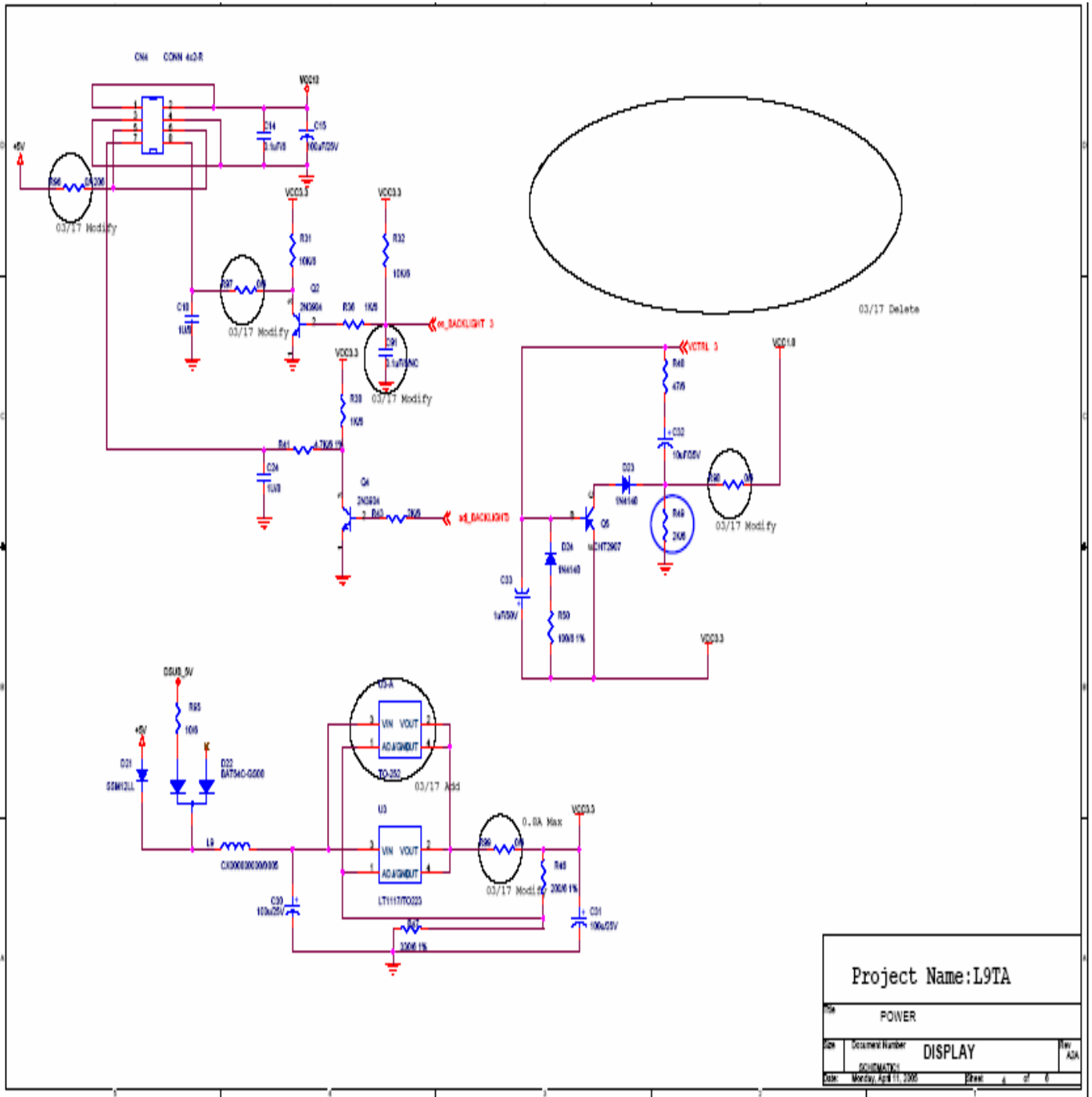

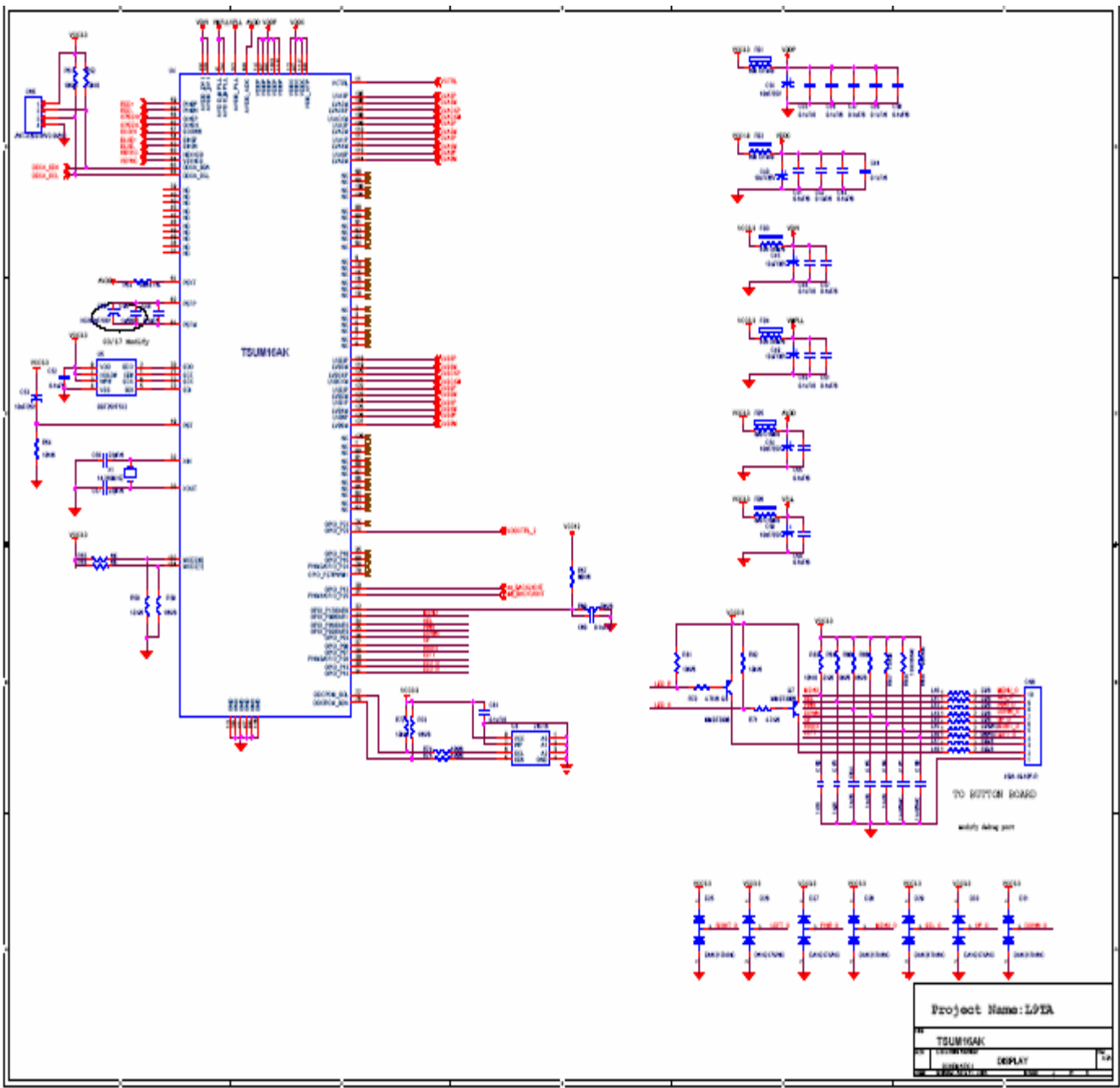

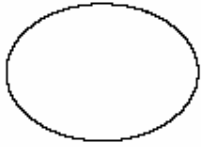

03/17 Delete

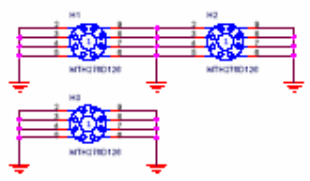
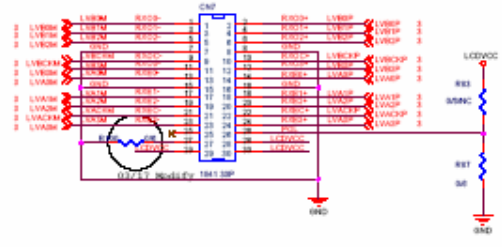
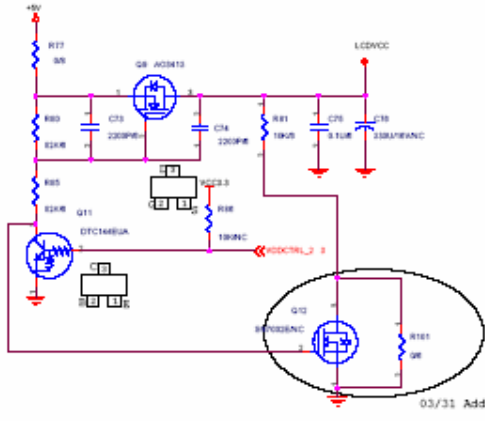

Project Name: L9TA	
PANEL	
Doc: L9TA120	Rev: A2A
DISPLAY	
SCHMATIC	
03/17/2011	03/17/2011

## Power Board Information

Panel P/N	Description	Current Type Value
AAM190EN129(AU)	19" M190EN04 REV:V5	7.0mA
AA0190EA108(CPT)	19" CLAA190EA05	7.0mA
AA190E03069( LG)	19"LM190E03 TLB1/TLB4	7.5mA
AAM190EX009(Samsung)	19"LTM190EX-L01	7.5mA
AA19EL01001(QDI)	19"QD190EL01REV:01	7.0mA
AA90ME13006(Hannstar)	19"HSD190ME13-A02	6.5mA

P/B P/N	Description
AS05B312D00	ADP/INV,FSP043-2PI01 90~264V GP
AS05B520207	ADP/INV,SLS0532D0248,90~264V,REV1A GP

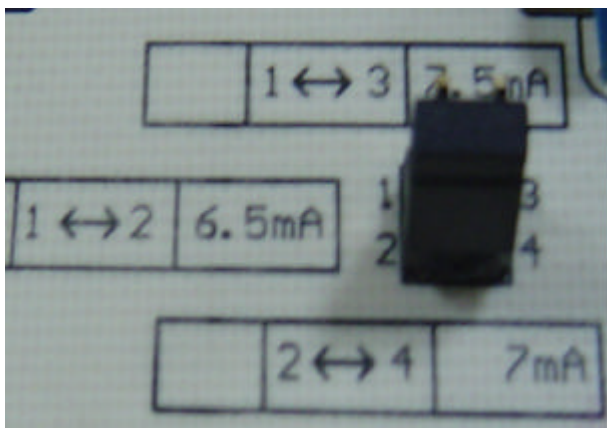

When the lamp current value is 7.0mA, the jumper should be done as the picture left shows